

WWI860 WCS PWash&TDos&9kg
W1 front-loader washing machine
with TwinDos and SingleWash for laundry care that saves time and energy.



- Precise and automatic detergent dispensing with TwinDos®
- QuickPowerWash ensures fast, efficient results in just 49 minutes
- Exclusive CapDosing range for different textiles and stains
- Display & convenient operation at your fingertips – ComfortSensor
- Miele@home – clever networking opens up new possibilities*

* Additional digital offer from Miele & Cie. KG. All smart applications are made possible with the Miele@home system. The range of functions can vary depending on the model and the country.

EAN: 4002516589815 / Material number: 12060520 / Old Material Number: 11WI8601ZA

Construction type	
Suitable for stacking	•
Side-by-side	•
Slot-in	•
Door hinge	right
Model	
Product brand	W1 White Edition
Front-loader	•
Spinning	
Max. spin speed	1600
Rinse hold	•
Without spin function	•
Design	
Appliance colour	Lotus white
Control panel colour	Lotus white
Door design	Obsidian black with chrome ring
Rotary selector colour	Lotus White / Chrome ring
Control panel version	5° inclined
Control type	Rotary control
Display	ComfortSensor white, 1 line
Cleaning performance	
Innovative PowerWash technology	•
TwinDos automatic detergent dispensing	•
CapDosing portioned dispensing	•
Stains option	•
Certified virus hygiene	•
Gentle laundry care	
Honeycomb drum	•
Load in kg	9,0
User convenience	
Networking with Miele@home	•
Delay start up to 24 hours	•
Time left display	•
Programme sequence indicator	•
MultiLingua	•
AutoClean detergent drawer	•
AddLoad	•
Efficiency and sustainability	
EcoFeedback	•
Low temperature wash "Cold" and "20 °C"	•
Automatic load control	•
Flow meter	•
Foam sensing	•
ProfiEco motor	•
Wash programmes	
QuickPowerWash	•
Automatic plus	•
Cottons (coloureds)	•
Minimum iron	•

WWI860 WCS PWash&TDos&9kg
 W1 front-loader washing machine
 with TwinDos and SingleWash for laundry care that saves time and energy.



EAN: 4002516589815 / Material number: 12060520 / Old Material Number: 11WI8601ZA

Delicates	•
Shirts	•
Silk (hand-washable)	•
Woollens (hand-washable)	•
Express 20	•
Dark garments / Denim	•
Outerwear	•
Proofing	•
Sportswear	•
Down duvets	•
Pillows	•
Down	•
Curtains	•
Cottons hygiene	•
Clean machine	•
Cottons arrow	•
First wash	•
Separate rinse/Starch	•
Drain / Spin	•
ECO 40-60	•
Washing extras	
SingleWash	•
Short	•
Soak	•
Pre-wash	•
Water plus	•
Additional rinse cycle	•
Extra quiet	•
Pre-ironing with steam	•
Buzzer	•
AllergoWash	•
Quality	
Counterweights made of cast iron	•
Safety	
Water protection system	Watercontrol-System
Safety lock	•
PIN-Code	•
Optical interface	•
Technical data	
Dimensions in mm (width)	596
Dimensions in mm (height)	850
Dimensions in mm (depth)	643
Appliance depth in mm with opened door	1077
Weight in kg	94
Total rated load in kW	2,10-2,40
Voltage in V	220-240
Fuse rating in A	10
Frequency in Hz	50
Length of supply lead in m	2
Accessories included	
UltraPhase 1 + 2	•

WWI860 WCS PWash&TDos&9kg
W1 front-loader washing machine
with TwinDos and SingleWash for laundry care that saves time and energy.



EAN: 4002516589815 / Material number: 12060520 / Old Material Number: 11WI8601ZA

Voucher for 5 Miele UltraPhase cartridges

Available display languages

Available display languages via MultiLingua

- deutsch, english (GB), français (FR), hrvatski, italiano, magyar, nederlands, polski, română, slovenščina, srpski, türkçe, ελληνικά

WWI860 WCS PWash&TDos&9kg
W1 front-loader washing machine
with TwinDos and SingleWash for laundry care that saves time and energy.

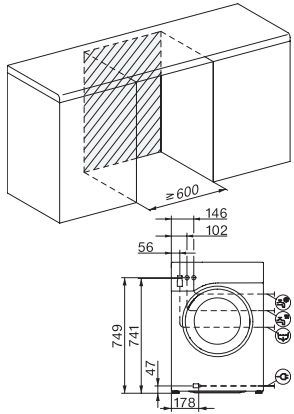

W1 drawing, facia 5 degree, measures in mm

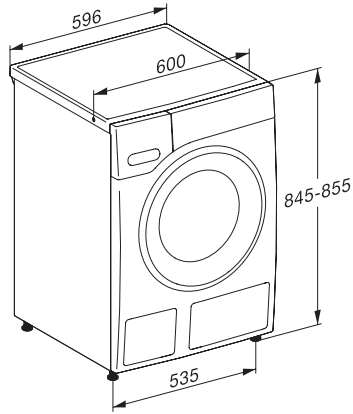

W1 drawing, facia 5 degree, measures in mm

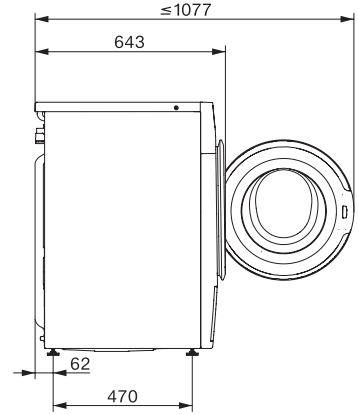

W1 drawing, facia 5 degree, measures in mm

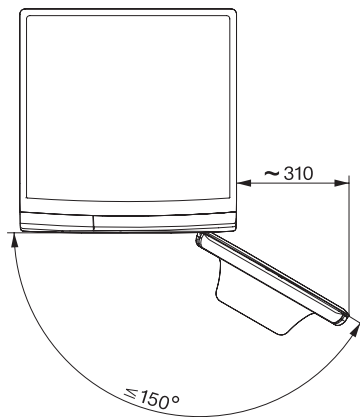

W1 drawing, facia 5 degree, measures in mm