

FNS 4782 E

Freestanding freezer

with NoFrost and added convenience for the perfect side-by-side combination.



- No icing up of food and no need to defrost thanks to NoFrost
- Soft closing of the door with SoftClose
- More space for particularly large frozen food – XXL box
- Convenient and effortless opening – EasyOpen
- Food is frozen quickly and gently – SuperFreeze

EAN: 4002516517405 / Material number: 11953230 / Old Material Number: 37478250EU1

Appliance category	
Freezer	•
Construction type	
Freestanding appliance	•
Door hinge	Left
Convertible door hinging	•
Side-by-side enabled	•
Design	
Casing colour	Silver
Front colour	Stainless steel/CleanSteel
User convenience	
Networking with Miele@home	•
NoFrost	•
VarioRoom	•
SoftClose	•
Concealed door opener	EasyOpen lever handle
Control system	
Operating concept	SensorTouch
Precise adjustment	Freezer temperature
Independent temperature regulation of fridge and freezer zones	No
SuperFreeze	•
No. of temperature zones	1
Sabbath mode	•
Party mode	•
Freezer/Freezer section	
Number of freezer drawers	7
including XXL box	1
Efficiency and sustainability	
Energy efficiency class (A–G)	E
Annual energy consumption in kWh	247,80
Energy consumption in 24 h in kWh	0,67
Safety	
Lock function	•
Acoustic door alarm	•
Acoustic temperature alarm	•
Optical door alarm	•
Optical temperature alarm	•
Power cut indication for freezer section	•
Internal heater for operation with low ambient temperatures	•
Technical data	
Appliance width in mm	600
Appliance height in mm	1855
Appliance depth in mm	675
Weight in kg	67,2
Climate class	SN-T
4* freezer compartment in l	278
Total usable capacity in l	278
Storage time in case of fault in h	18
Freezer capacity in kg/24 h	18,00

FNS 4782 E

Freestanding freezer

with NoFrost and added convenience for the perfect side-by-side combination.



EAN: 4002516517405 / Material number: 11953230 / Old Material Number: 37478250EU1

Acoustic airborne noise emission class (A-D)	C
Sound emissions in dB(A) re 1 pW	38
Current consumption (mA)	1300
Voltage in V	220-240
Fuse rating in A	10
Number of phases	1
Frequency in Hz	50-60
Length of supply lead in m	2,1
Replacing lamps	Service
Accessories included	
Ice cube tray	•
Side-by-Side kit	•

FNS 4782 E

Freestanding freezer

with NoFrost and added convenience for the perfect side-by-side combination.

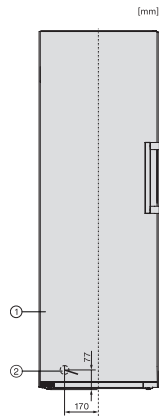

FNS4782E, FNS4782D, FNS4382D N, FNS4382E N, Nordic, installation (footnote*) (installation drawings)

*1. View from the front, 2. Mains connection cable, L = 2100 mm

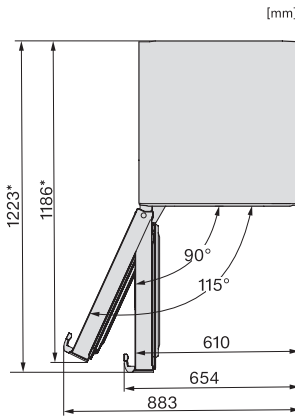

FNS4782E, FNS4782D, FNS4782E N, FNS4782D N, FNS4882D N, FNS4882E N, top view (footnote*) (installation drawings)

*To achieve the declared energy consumption, the spacers supplied with the unit must be used. This increases the depth of the unit by approx. 15 mm. The unit is fully functional without the use of the spacers, but has a slightly higher energy consumption.

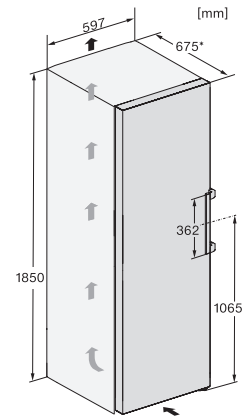

FNS4782E, FNS4782D, FNS4782E C, FNS4382E N, Nordic, installation sketch (footnote*) (installation drawings)

*To achieve the declared energy consumption, the spacers supplied with the unit must be used. This increases the depth of the unit by approx. 15 mm. The unit is fully functional without the use of the spacers, but has a slightly higher energy consumption.

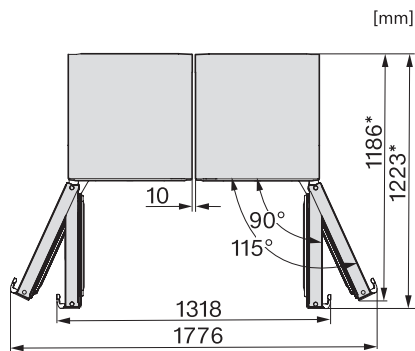

KS4783DD, KS4783ED, FNS4782E, FNS4782D, top view, Side-by-Side (footnote*) (installation drawings)

*To achieve the declared energy consumption, the spacers supplied with the unit must be used. This increases the depth of the unit by approx. 15 mm. The unit is fully functional without the use of the spacers, but has a slightly higher energy consumption.

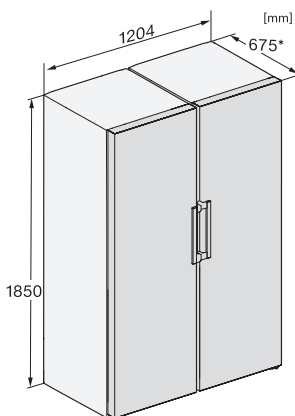

KS4783DD, KS4383ED, FNS4782E, FNS4782D, installation sketch, Side-by-Side (footnote*) (installation drawings)

*To achieve the declared energy consumption, the spacers supplied with the unit must be used. This increases the depth of the unit by approx. 15 mm. The unit is fully functional without the use of the spacers, but has a slightly higher energy consumption.

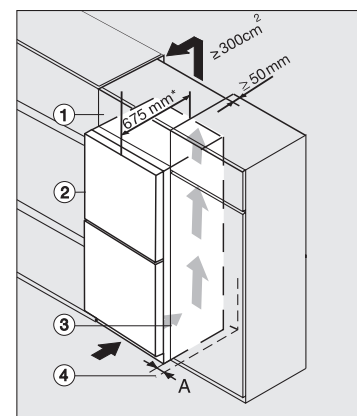

Integrating freestanding refrigeration appliance in a run of kitchen units, edt/cs, ws, bst, el (footnote)

1. Top box, 2. Refrigeration appliance, door depth = 75 mm, 3. Housing unit, 4. Wall, A = 25 mm (with recessed grip)/60 mm (with handle), * The appliance depth is increased by approx. 15 mm for refrigeration appliances with wall spacers fitted.