

WTR860WPM PWash&TDos 8/5kg

WT1 washer-dryer:

with TwinDos and QuickPower – ready-to-wear clothes at the touch of a button.



EAN: 4002516371021 / Material number: 11576550 / Old Material Number: 11TR8604GB

<b>Construction type</b>	
Suitable for stacking	•
Side-by-side	•
Slot-in	•
Can be built-under	•
Door hinge	right
<b>Model</b>	
Front-loader	•
<b>Washing machine with TD fct.</b>	
Continuous washing and drying cycle	•
Electronic residual moisture sensing	•
Condenser dryers with water cooling	•
Thermospin	•
<b>Spinning</b>	
Max. spin speed	1600
Rinse hold	•
Without spin function	•
<b>Design</b>	
Appliance colour	Lotus white
Control panel colour	Lotus white
Door design	Chrome
Control panel version	Straight
Control type	Touch control
Display	MTouch
<b>Cleaning performance</b>	
PowerWash	•
TwinDos automatic detergent dispensing	•
CapDosing portioned dispensing	•
Stains option	•
Certified virus hygiene	•
<b>Gentle laundry care</b>	
Honeycomb drum	•
Load in kg for washing	8,0
Load in kg when drying	5,0
PerfectCare technology	•
<b>User convenience</b>	
Networking with Miele@home	•
Delay start up to 24 hours	•
Time left display	•
Time of day display	•
Programme sequence indicator	in display
Favourite programmes	•
Automatic rinse out fluff	•
Drum lighting	LED
MultiLingua	•
AutoClean detergent drawer	•
AddLoad	•
<b>Efficiency and sustainability</b>	
Energy efficiency class (A–G)	A
Energy efficiency class for washing and drying (A–G)	D

WTR860WPM PWash&TDos 8/5kg

WT1 washer-dryer:

with TwinDos and QuickPower – ready-to-wear clothes at the touch of a button.



EAN: 4002516371021 / Material number: 11576550 / Old Material Number: 11TR8604GB

Weighted energy consumption per 100 operating cycles for the complete operating cycle in kWh	262
Weighted energy consumption per 100 operating cycles for the wash cycle in kWh	46
Weighted water consumption per operating cycle for the wash cycle in l	47
Weighted water consumption per operating cycle for the complete operating cycle in l	68
Spin efficiency class	A
Acoustic airborne noise emission class (spin cycle)	A
Sound emissions during spin cycle in dB(A) re 1 pW	69
Programme running time at nominal capacity for the wash cycle	219
Programme running time at nominal capacity for the complete operating cycle	389
Power rating in off mode in W	0,10
Power rating in networked standby in W	0,50
Low temperature wash "Cold" and "20 °C"	•
Automatic load control	•
Flow meter	•
Foam sensing	•
ProfiEco motor	•
<b>Wash programmes</b>	
QuickPower	•
Automatic	•
Cottons (coloureds)	•
Minimum iron	•
Shirts	•
Silk (hand-washable)	•
Woollens (hand-washable)	•
Express	•
Dark garments	•
Denim	•
Outerwear	•
Proofing	•
Sportswear	•
Trainers	•
Pillows	•
Down	•
Curtains	•
Cottons hygiene	•
Clean machine	•
Cottons arrow	•
First wash	•
Starch	•
ECO 40-60	•
<b>Drying programmes</b>	
QuickPower	•
Automatic	•
Cottons (coloureds)	•
Cottons arrow	•
Minimum iron	•

WTR860WPM PWash&TDos 8/5kg

WT1 washer-dryer:

with TwinDos and QuickPower – ready-to-wear clothes at the touch of a button.

EAN: 4002516371021 / Material number: 11576550 / Old Material Number: 11TR8604GB

Delicates	•
Shirts	•
Silk	•
Woollens	•
Express	•
Dark garments	•
Denim	•
Outerwear	•
Proofing	•
Sportswear	•
Trainers	•
Standard pillows	•
Cottons hygiene	•
First wash	•
Cool air	•
Warm air	•
Freshen up	•
Steam care	•
<b>Drying extras</b>	
Anti-crease	•
<b>Washing extras</b>	
Short	•
Soak	•
Pre-wash	•
Water plus	•
Additional rinse cycle	•
Pre-ironing with steam	•
Buzzer	•
AllergoWash	•
Single	•
<b>Quality</b>	
Counterweights made of cast iron	•
<b>Safety</b>	
Water protection system	Waterproof-Metal
PIN-Code	•
Optical interface	•
<b>Technical data</b>	
Dimensions in mm (width)	596
Dimensions in mm (height)	850
Dimensions in mm (depth)	637
Appliance depth in mm with opened door	1055
Weight in kg	98
Total rated load in kW	2,10-2,40
Voltage in V	220-240
Fuse rating in A	13
Frequency in Hz	50
Length of supply lead in m	2
<b>Accessories included</b>	
3 Caps	•
UltraPhase 1 + 2	•
Voucher for 5 Miele UltraPhase cartridges	•

WTR860WPM PWash&TDos 8/5kg

WT1 washer-dryer:

with TwinDos and QuickPower – ready-to-wear clothes at the touch of a button.



EAN: 4002516371021 / Material number: 11576550 / Old Material Number: 11TR8604GB

#### Available display languages

Available display languages via MultiLingua

bahasa malaysia, dansk,  
deutsch, english (AU),  
english (CA), english (GB),  
english (US), español,  
français (CA), français  
(FR), hrvatski, italiano,  
magyar, nederlands,  
norsk, polski, português,  
русский, română,  
slovenčina, slovenščina,  
srpski, suomi, svenska,  
türkçe, українська, čeština,  
ελληνικά,

WTR860WPM PWash&TDos 8/5kg

WT1 washer-dryer:

with TwinDos and QuickPower – ready-to-wear clothes at the touch of a button.

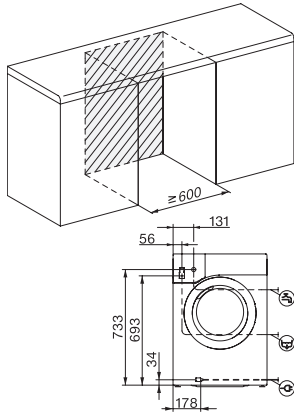

WT1 8/5 kg, installation drawing, slanted facia or straight facia, measures in mm

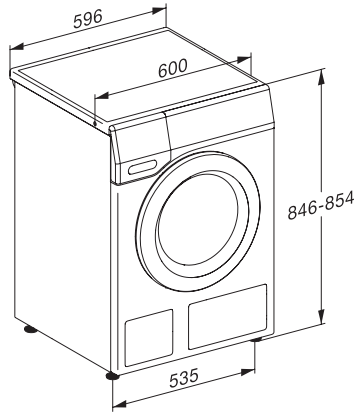

WT1 8/5 kg, drawing, slanted facia or straight facia, measures in mm

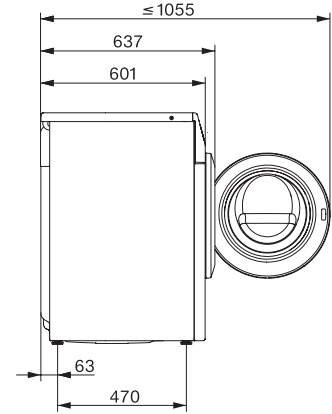

WT1 8/5 kg, drawing, slanted facia or straight facia, measures in mm

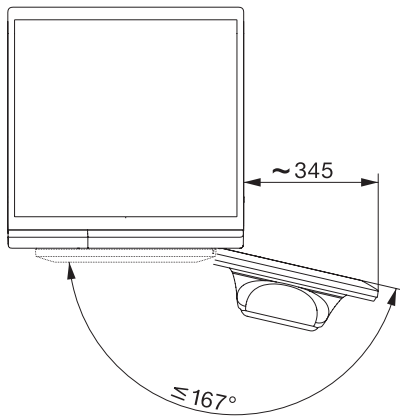

WT1 8/5 kg, drawing, slanted facia or straight facia, measures in mm