

F 12020 S-2

Freestanding freezer

with maximum energy efficiency and Super freeze for intelligent freezing.



- Freezer compartment can be increased in size with-VarioRoom
- Rapid and gentle freezing of food – Super freeze
- Acoustic alarm for the freezer section – audible alert
- Freezes at ambient temperatures of up to -15 °C – FrostProof

EAN: 4002515117569 / Material number: 09275780 / Old Material Number: 37120202GB

Appliance category	
Freezer	•
Construction type	
Freestanding appliance	•
Door hinge	right
Convertible door hinging	•
Design	
Casing colour	White
Front colour	White
User convenience	
VarioRoom	•
Control system	
Operating concept	PicTronic
Fridge compartment can be switched off	No
Independent temperature regulation of fridge and freezer zones	No
SuperFreeze	•
No. of temperature zones	1
Freezer/Freezer section	
Number of freezer drawers	4
Efficiency and sustainability	
Energy efficiency class (A–G)	E
Annual energy consumption in kWh	171,14
Energy consumption in 24 h in kWh	0,46
Safety	
Lock function	•
Acoustic temperature alarm	•
Optical temperature alarm	•
Power cut indication for freezer section	•
Internal heater for operation with low ambient temperatures	•
Technical data	
Appliance width in mm	602
Appliance height in mm	851
Appliance depth in mm	628
Weight in kg	40,2
Climate class	SN-T
4* freezer compartment in l	103
Total usable capacity in l	103
Storage time in case of fault in h	17
Freezer capacity in kg/24 h	6,00
Acoustic airborne noise emission class (A–D)	C
Sound emissions in dB(A) re 1 pW	39
Current consumption (mA)	1300
Voltage in V	220-240
Fuse rating in A	13
Number of phases	1
Frequency in Hz	50
Length of supply lead in m	2,0
Replacing lamps	Service
Accessories included	
Ice cube tray	•

F 12020 S-2

Freestanding freezer

with maximum energy efficiency and Super freeze for intelligent freezing.

[mm]

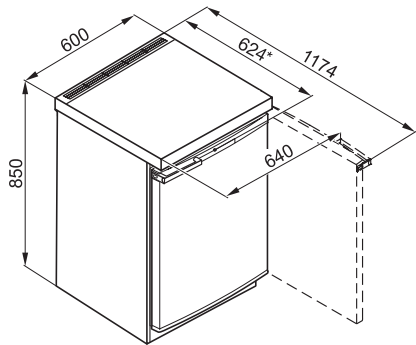

F12020S-2, F12020S-3 (installation drawings) (*foonote)

*To ensure that energy consumption as stated is achieved, machines should be used together with the enclosed spacer brackets. This increases the total depth of the unit by approx. 3.5 cm. , Machines are still fully functional when operated without these brackets but have a slightly higher energy consumption.