

DAR 1150

48-inch extractor unit

for perfect combination with Ranges and Rangetops.



- Customized kitchen design – fully integrated in 45 1/2 (1155) in (mm)
- Perfect illumination – LED ClearView lighting
- Dishwasher-safe – 4 high-quality stainless steel grease filters
- Safe and easy to clean – Miele CleanCover
- Auto-vent safety sensor – protects against overheating

EAN: 4002515446829 / Material number: 09753510 / Old Material Number: 28115050USA

Design	
Insert ventilation hood	•
Required accessories	
Blower	•
Operating modes	
Recirculated mode	Exhaust air
External operation possible	•
User convenience	
Rotary knob	•
Power levels (number excl. Intensive)	3
Temperature sensor	•
CleanCover	•
Cleaning convenience	
Dishwasher-safe grease collection channel	•
Filter system	
Number of dishwasher-safe stainless steel baffle filters	4
Lighting	
LED	•
Number x W	4 x 3 W
Fan option (buy separately)	
DRIB XXL internal blower in CFM (m ³ /h)	1869
DREB XXL external blower in CFM (m ³ /h)	1869
Technical data	
Canopy width in in.(mm)	45 1/2 (1155)
Canopy width in inches	47 15/16
Canopy height in in.(mm)	17 3/4 (449)
Canopy depth in in.(mm)	22 7/8 (579)
Net weight in lbs. (kg)	56 (25.0)
Length of electrical wire in ft (m)	2 (0.8)
Standard plug fitted	•
Total connected load in kW	0.81
Voltage in V	120
Fuse rating in A	15
Number of phases	1
Installation note	
Vent connection at top	•
Diameter of vent connection in in.(mm)	9 7/8 (250)
Standard accessories	
Non-return flap	•

DAR 1150
48-inch extractor unit
for perfect combination with Ranges and Rangetops.

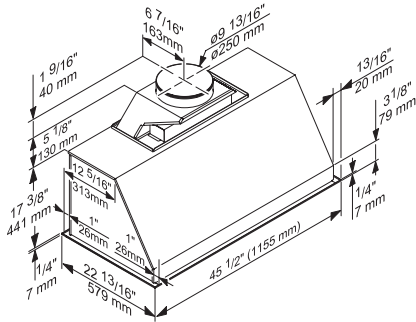

DAR1150 (Installation drawing)