

DA 2450

Extractor unit

with energy-efficient LED lighting and rotary dials for easy use



- Customised kitchen design – fully integrated in 532 mm width
- Powerful – 590 m³/h on the booster setting
- Efficient filtration- 10-ply stainless-steel grease filter
- Safe and easy to clean – Miele CleanCover
- Suitable for every home – for extraction or recirculation



EAN: 4002515792209 / Material number: 10568390 / Old Material Number: 28245055GB

Construction type	
Integrated extractor	•
Construction type and design	
Colour	Stainless steel
Operating modes	
Type of air guide	Can be retrofitted
Recirculation conversion kit (order separately)	DUU 151
Active charcoal filter (order separately)	DKF 15-P
User convenience	
Rotary knob	•
Electronic controls	•
Power levels (number without Booster level)	2
Easy-to-clean canopy interior – CleanCover	•
Efficiency and sustainability	
Energy efficiency class (A+++ – D)	A
Annual energy consumption in kWh/year	52.6
Fluid dynamic efficiency class	A
Lighting efficiency class	A
Grease filtering efficiency class	B
Filter system	
Number of dishwasher-safe stainless steel grease filters (10-ply)	1
Lighting	
LED	•
Number x W	2 x 3 W
Light intensity in lx	330 lx
Colour temperature in K	3000 Kelvin
Fan	
Dual-action fan	•
AC motor	•
Exhaust air	
Air throughput in Level 1 (m ³ /h) according to EN 61591	230
Air throughput in Level 2 (m ³ /h) according to EN 61591	350
Air throughput in Booster level (m ³ /h) according to EN 61591	590
Sound power in Level 1 (dB(A) re 1 pW) according to EN 60704-3	47.0
Sound power in Level 2 (dB(A) re 1 pW) according to EN 60704-3	54.0
Sound power in Booster level (dB(A) re 1 pW) acc. to EN 60704-3	66.0
Sound pressure in Level 1 (dB(A) re 20 µPa) according to EN 60704-2-13	32.0
Sound pressure in Level 2 (dB(A) re 20 µPa) according to EN 60704-2-13	40.0
Sound pressure in Booster level (dB(A) re 20 µPa) acc. to EN 60704-2-13	52.0
Recirculation	
Air throughput in Level 1 (m ³ /h) according to EN 61591	185
Air throughput in Level 2 (m ³ /h) according to EN 61591	305
Air throughput in Intensive level (m ³ /h) according to EN 61591	525

DA 2450

Extractor unit

with energy-efficient LED lighting and rotary dials for easy use



EAN: 4002515792209 / Material number: 10568390 / Old Material Number: 28245055GB

Sound power in Level 1 (dB(A) re 1 pW) according to EN 60704-3	52.0
Noise power level in Intensive level (dB(A) re 1 pW) according to EN 60704-3	71.0
Sound power in Level 2 (dB(A) re 1 pW) according to EN 60704-3	61.0
Sound pressure in Level 1 (dB(A) re 20 µPa) according to EN 60704-2-13	38.0
Sound pressure in Level 2 (dB(A) re 20 µPa) according to EN 60704-2-13	47.0
Noise pressure level in Intensive level (dB(A) re 20 µPa) according to EN 60704-2-13	57.0

Technical data	
Canopy width in mm	532
Canopy height in mm	50
Canopy depth in mm	372
Minimum height above electric hobs in mm	450
Net weight in kg	10.2
Length of supply lead in m	1.5
Standard plug fitted	•
Minimum safety distance above gas hobs (max. 12.6 kW total power, burner ≤ 4.5 kW) in mm	650
Total rated load in kW	0.22
Voltage in V	230
Fuse rating in A	10
Number of phases	1
Frequency in Hz	50
Installation notes	
Extraction ducting connection at top	•
Extraction connection at top and rear	•
Diameter of exhaust duct in mm	150
Accessories included	
Non-return flap	•
Optional accessories	
Active charcoal filter	Ja

DA 2450

Extractor unit

with energy-efficient LED lighting and rotary dials for easy use

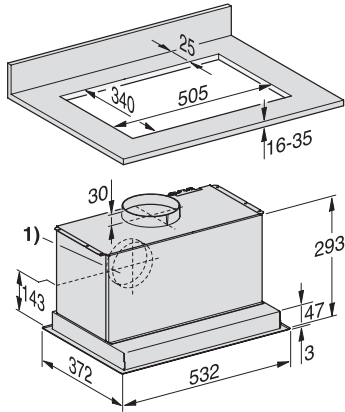

DA2450, DA2450-1, DA2558 (Installation drawing)

1) Vent connection alternatively to rear, You will find further detailed measurements in the instructions for use!