

## KM 8462 FL

Induction hob with onset controls

620 mm | Individual cooking zones and PowerFlex cooking area



- 4 cooking zones incl. 1 powerful PowerFlex cooking area
- Precise settings via SingleSlide central slider incl. networking
- Shortest heat-up times thanks to Booster level
- A width of 620 mm for surface-mounted or flush-fit installation

EAN: 4002516973027 / Material number: 12944650 /  
Old Material Number: 26184621GB

General information	
Model identifier	KM 8462 FL
Manufacturer material number	12944650
EAN number	4002516973027
Marketing class	Gold
Heating type	
Heating type	Induction
Construction type	
Independent of cooker	•
Design	
Elegant glass ceramic surface	•
Ceramic surface colour	Black
Flush	•
Surface-mounted installation	•
Cooking zone details	
Number of cooking zones	4
Number of cooking areas	1
Maximum number of pans	4
PowerFlex cooking zones	
No.	2
Type	PowerFlex cooking zone
Size in mm	Ø 120 – 230
Max. rating in W	2100
Max. Booster power rating in W	3650
1st cooking zone/cooking area	
Position	front left
Type	Dual-circuit ring
Size in mm	Ø 100-160
Max. rating in W	1400
Max. Booster power rating in W	2200
2nd cooking zone/cooking area	
Position	rear left
Type	Dual-circuit ring
Size in mm	Ø 120 – 190
Max. rating in W	1850
Max. Booster power rating in W	3000
3rd cooking zone/cooking area	
Position	right
Type	PowerFlex bridge
Size in mm	230x390
Max. rating in W	4200
Max. Booster power rating in W	7360
User convenience	
Networking with Miele@home	•
Con@ctivity	•
Pan and pan size recognition	•
Operation via sensor controls	SingleSlide
Display colour	Yellow

KM 8462 FL

Induction hob with onset controls

620 mm | Individual cooking zones and PowerFlex cooking area



EAN: 4002516973027 / Material number: 12944650 /

Old Material Number: 26184621GB

Permanent pan recognition	•
Stop & Go function	•
Wipe protection	•
Recall function	•
Minute minder	•
Safety switch-off	•
Auto heat-up	•
Keeping warm	•
Individual setting options (e.g. buzzers)	•
<b>Efficiency and sustainability</b>	
Power rating in off mode in W	0.3
Power rating in standby mode in W	0.8
Power rating in networked standby in W	2.0
Time until automatic switch to off mode in min	10
Time until automatic switch to standby in min	10
Time until automatic switch to networked standby in min	10
<b>Cleaning and care</b>	
Easy to clean ceramic glass	•
<b>Safety</b>	
Safety switch-off	•
Lock function	•
System lock	•
Integrated cooling fan	•
Overheating protection	•
Residual heat indicator	•
<b>Technical data</b>	
Dimensions (H x W x D) in mm	51 x 620 x 520
Dimensions (W x D) in mm	620 x 51 x 520
Dimensions in mm (width)	620
Dimensions in mm (height)	51
Dimensions in mm (depth)	520
Cut-out dimensions (W x D) with surface-mounted installation in mm	560 mm – 600 mm x 490 mm – 500 mm
Cut-out dimensions (W x D) with flush-fit installation in mm	600/624 x 500/524
Casing height incl. connection box in mm	51
Cutout dimensions in mm (width) with surface-mounted installation	560 mm – 600 mm
Cutout dimensions in mm (depth) with surface-mounted installation	490 mm – 500 mm
Internal cutout dimensions in mm (width) with flush installation	600
Internal cutout dimensions in mm (depth) with flush installation	500
Weight in kg	10
External cutout dimensions in mm (width) with flush installation	624
External cutout dimensions in mm (depth) with flush installation	524
Total rated load in kW	7.36

KM 8462 FL

Induction hob with onset controls

620 mm | Individual cooking zones and PowerFlex cooking area



EAN: 4002516973027 / Material number: 12944650 /  
Old Material Number: 26184621GB

Length of supply lead in m	1.6
Voltage in V	230
Frequency in Hz	50-60
<b>Accessories included</b>	
Mains cable	Yes

## KM 8462 FL

Induction hob with onset controls

620 mm | Individual cooking zones and PowerFlex cooking area

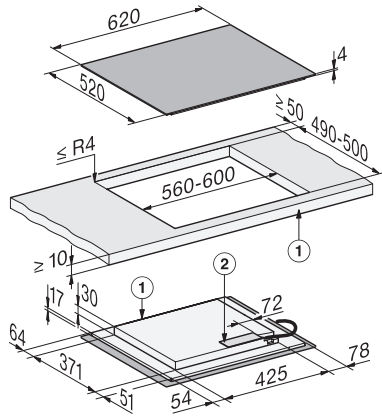

KM8462FL surface-mounted (\*Fußnote) Installation drawing

1) front, 2) Mains connection box, The mains connection cable (L = 1440 mm) is enclosed loose

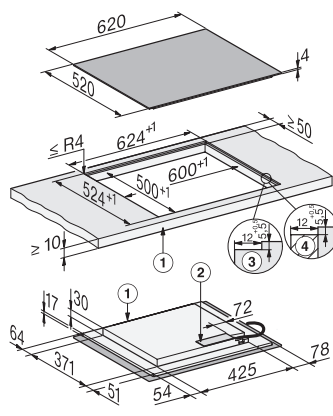

KM8462FL flush (\*Fußnote) (Installation drawing)

1) front, 2) Mains connection box, The mains connection cable (L = 1440 mm) is enclosed loosely, 3) Step milling natural stone worktop, 4) Wooden strip 12 mm (no supplied accessories)