

TSD643WP EcoSpeed&9kg

T1 heat-pump dryer:

9 kg | DirectSensor | DryCare 40 | HygieneDry | Miele@home



- Tested for 20 years of perfect laundry care\*
- Heat pump technology – low consumption, gentle drying
- Save time sorting your laundry; DryCare 40 is perfect for a 40 °C wash\*\*
- EcoSpeed efficiently reduces the drying time by 20 minutes\*\*\*
- HygieneDry removes up to 99.99 % of bacteria\* and 99.9 % of viruses\*\*\*\*

\* During the development phase of the W1 washing machine series, Miele tested models and core components in 5000 wash loads (= 5 wash loads per week for 50 weeks per year) in various programmes. More: [miele.com/20years](https://www.miele.com/20years)

\*\* Not suitable for woollens or silks.

\*\*\* Compared to Miele tumble dryers without EcoSpeed with the same load size and energy efficiency class. Tested in the "Cottons" programme with a full load size.

\*\*\*\* Tested for *Bacillus subtilis* and *Saccharomyces cerevisiae* bacteria in the HygieneDry drying level with half load. A description of the relevant methodology can be found at the following link: <https://www.miele.de/testkriterien-trockner>



EAN: 4002516867494 / Material number: 12719180 /  
Old Material Number: 12SD6432GB

Construction type	
Suitable for stacking	•
Side-by-side	•
Slot-in	•
Door hinge	left, Reversible
Convertible door hinging	•
Model	
Product brand	T1 White Edition
Heat pump dryer	•
Design	
Appliance colour	Lotus white
Control panel colour	Lotus white
Door design	Lotus white
Rotary selector colour	Lotus White
Control panel version	5° inclined
Control type	Rotary control
Display	DirectSensor white, 7 segment
Drying results	
PerfectDry precision drying	•
FragranceDos fragrance system	•
Intelligent drum reversal	•
HygieneDry	•
Gentle laundry care	
Honeycomb drum	•
Load in kg	9.0
User convenience	
Networking with Miele@home	•
Wash2Dry	•
Delay start up to 24 hours	•
Time left display	•
Programme sequence indicator	No
Drum lighting	LED
Condensate container	•
Integrated condensed water drainage	•
AddLoad	•
Efficiency and sustainability	
Energy efficiency class (A+++ – D)	A+++
Annual energy consumption in kWh	194
Duration in minutes in the standard programme	187
Noise in the Cottons programme with full load in db(A) re 1 pW	66
Condensation efficiency class	A
Energy consumption in kWh in the Cottons Normal dry standard programme with a full load	1.60
EcoDry technology	•
Maintenance-free heat exchanger	•
ProfiEco motor	•

TSD643WP EcoSpeed&9kg

T1 heat-pump dryer:

9 kg | DirectSensor | DryCare 40 | HygieneDry | Miele@home



EAN: 4002516867494 / Material number: 12719180 /

Old Material Number: 12SD6432GB

EcoSpeed	•
<b>Drying programmes</b>	
Cottons (coloureds)	•
Cottons arrow	•
Minimum iron	•
Delicates	•
Shirts	•
Woollens handcare	•
Express	•
Proofing	•
Bed linen	•
Warm air/DryFresh	•
<b>Drying extras</b>	
Anti-crease	•
Buzzer	•
DryCare 40	•
<b>Quality</b>	
Soft ribs	•
<b>Safety</b>	
PIN-Code	•
Empty out container indicator	•
Clean filter indication	•
Optical interface	•
<b>Technical data</b>	
Dimensions in mm (width)	596
Dimensions in mm (height)	850
Dimensions in mm (depth)	643
Appliance depth in mm with opened door	1077
Weight in kg	54
Total rated load in kW	1.10
Voltage in V	220-240
Fuse rating in A	13
Frequency in Hz	50
Length of supply lead in m	2.0
Hermetically sealed	•
Type of coolant	R290
Refrigerant quantity in kg	0.14
Refrigerant global warming potential in CO <sub>2</sub> e	3
Appliance global warming potential in CO <sub>2</sub> e	0.42
Replacing lamps	Service
<b>Accessories included</b>	
Fragrance flacon	•
Voucher for a second fragrance flacon	•

TSD643WP EcoSpeed&9kg

T1 heat-pump dryer:

9 kg | DirectSensor | DryCare 40 | HygieneDry | Miele@home



T1 installation drawing, facia 5 degree, measures in mm

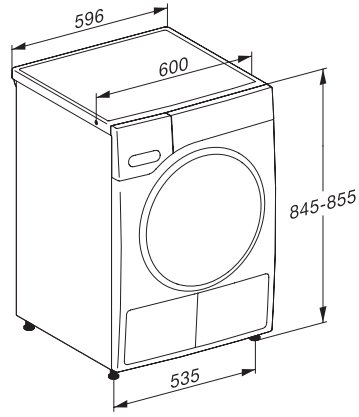

T1 drawing, facia 5 degree, measures in mm

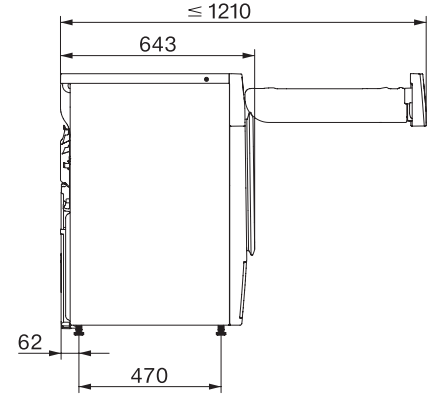

T1 drawing, facia 5 degree, with porthole, measures in mm

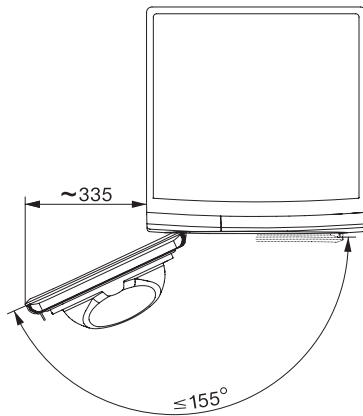

T1 drawing, facia 5 degree, measures in mm