

TEC645WP EcoSpeed&8kg

T1 heat-pump dryer:

8 kg | DirectSensor | Miele@home | EcoDry technology | FragranceDos



- Tested for 20 years of perfect laundry care*
- Heat pump technology – low consumption, gentle drying
- EcoSpeed efficiently reduces the drying time by 20 minutes**
- Complete app control of your tumble dryer with Miele@home***
- EcoDry for efficient performance over the entire tumble dryer service life****

* During the development phase of the W1 washing machine series, Miele tested models and core components in 5000 wash loads (= 5 wash loads per week for 50 weeks per year) in various programmes. More: miele.com/20years

** Compared to Miele tumble dryers without EcoSpeed with the same load size and energy efficiency class. Tested in the "Cottons" programme with a full load size.

*** Additional digital offer from Miele & Cie. KG. All smart applications are made possible with the Miele@home system. The range of functions can vary depending on the model and the country.

**** Patent EP 2 455 537



EAN: 4002516869917 / Material number: 12719160 / Old Material Number: 12EC6452GB

Construction type

Suitable for stacking	•
Side-by-side	•
Slot-in	•
Can be built-under	•
Door hinge	left

Model

Product brand	T1 Chrome Edition
Heat pump dryer	•

Design

Appliance colour	Lotus white
Control panel colour	Lotus white
Door design	Graphite grey PearlFinish
Rotary selector colour	Lotus White
Control panel version	Straight
Control type	Rotary control
Display	DirectSensor white, 7 segment

Drying results

PerfectDry precision drying	•
FragranceDos fragrance system	•
Intelligent drum reversal	•

Gentle laundry care

Honeycomb drum	•
Load in kg	8.0

User convenience

Networking with Miele@home	•
Wash2Dry	•
Delay start up to 24 hours	•
Time left display	•
Programme sequence indicator	No
Drum lighting	LED
Condensate container	•
Integrated condensed water drainage	•
AddLoad	•

Efficiency and sustainability

Energy efficiency class (A+++ – D)	A+++
Annual energy consumption in kWh	172
Duration in minutes in the standard programme	170
Noise in the Cottons programme with full load in db(A) re 1 pW	66
Condensation efficiency class	A
Energy consumption in kWh in the Cottons Normal dry standard programme with a full load	1.40
EcoDry technology	•
Maintenance-free heat exchanger	•
ProfiEco motor	•
EcoSpeed	•

TEC645WP EcoSpeed&8kg

T1 heat-pump dryer:

8 kg | DirectSensor | Miele@home | EcoDry technology | FragranceDos



EAN: 4002516869917 / Material number: 12719160 / Old Material Number: 12EC6452GB

Drying programmes	
Cottons (coloureds)	•
Cottons arrow	•
Minimum iron	•
Delicates	•
Shirts	•
Woollens handcare	•
Express	•
Proofing	•
Bed linen	•
Warm air/DryFresh	•
Drying extras	
Anti-crease	•
Gentle tumble	•
Buzzer	•
Quality	
Soft ribs	•
Safety	
PIN-Code	•
Empty out container indicator	•
Clean filter indication	•
Optical interface	•
Technical data	
Dimensions in mm (width)	596
Dimensions in mm (height)	850
Dimensions in mm (depth)	636
Appliance depth in mm with opened door	1054
Weight in kg	53
Total rated load in kW	1.10
Voltage in V	220-240
Fuse rating in A	13
Frequency in Hz	50
Length of supply lead in m	2.0
Hermetically sealed	•
Type of coolant	R290
Refrigerant quantity in kg	0.14
Refrigerant global warming potential in CO ₂ e	3
Appliance global warming potential in CO ₂ e	0.42
Replacing lamps	Service
Accessories included	
Fragrance flacon	•
Voucher for a second fragrance flacon	•

TEC645WP EcoSpeed&8kg

T1 heat-pump dryer:

8 kg | DirectSensor | Miele@home | EcoDry technology | FragranceDos



T1 installation drawing, slanted facia or straight facia, measures in mm

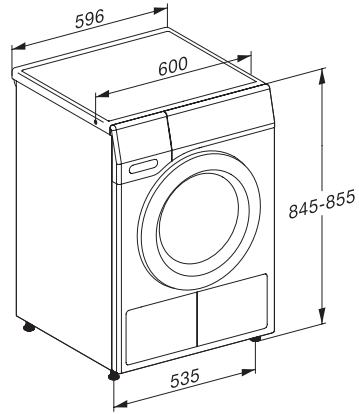

T1 drawing, slanted facia or straight facia, measures in mm

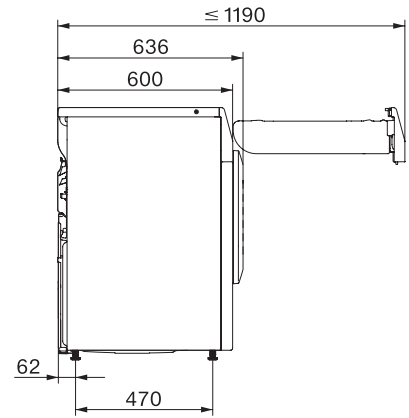

T1 drawing, slanted facia or straight facia, with porthole, measures in mm

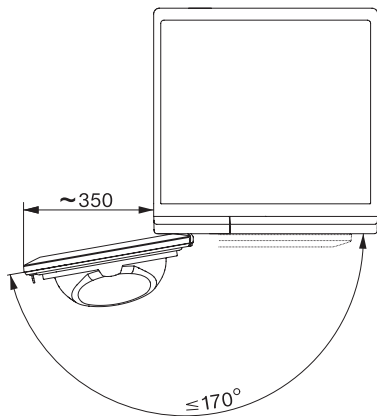

T1 drawing, slanted facia or straight facia, measures in mm