

TQ 1000 WP Nova Edition
T2 heat-pump dryer
9 kg | M Touch Pro | QuickPowerDry | SteamCare | WoolDry

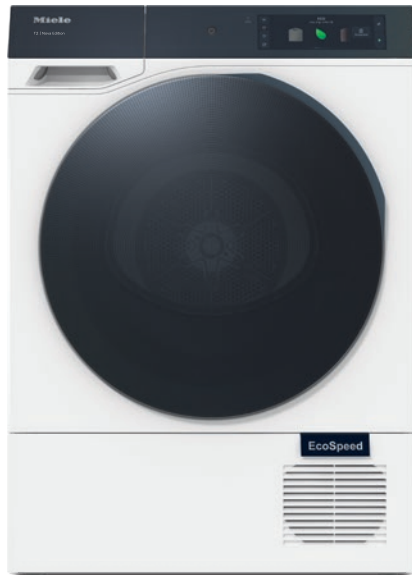

- Tested for 20 years of perfect laundry care
- With QuickPowerDry you can tumble dry your laundry in just 49 minutes*
- WoolDry ensures that your woollen textiles are dried gently in the machine
- SteamCare reduces ironing time by up to 50 % and freshens up your clothes
- The large colour M Touch Pro display makes operation highly convenient

* Programme running time may vary depending on the load. Time measured for 4 kg of minimum iron items with 30 % residual moisture.



EAN: 4002516860921 / Material number: 12699270 /
Old Material Number: 12Q10001GB

Construction type	
Suitable for stacking	•
Side-by-side	•
Slot-in	•
Door hinge	left
Model	
Heat pump dryer	•
Design	
Appliance colour	Lotus white
Door and panel design	BlackEffect
Control panel version	Slanted
Control type	Touch control
Display	M Touch Pro
AmbientLight	•
MotionReact	•
Drying results	
PerfectDry precision drying	•
FragranceDos ² fragrance system	•
PowerDry	•
Intelligent drum reversal	•
HygieneDry	•
Gentle laundry care	
SilenceDrum	•
Load in kg	9.0
User convenience	
Networking with Miele@home	•
Wash2Dry	•
Delay start up to 24 hours	•
Time left display	•
Time of day display	•
Programme sequence indicator	Yes
Information text	•
Drum lighting	LED
MultiLingua	•
Acoustics package for the lowest sound emissions	•
Condensate container	•
Integrated condensed water drainage	•
AddLoad	•
ComfortOpen	•
Efficiency and sustainability	
Energy efficiency class (A+++ – D)	A+++
More economical than the threshold value (24) for energy efficiency class A+++	10%
Annual energy consumption in kWh	170
Duration in minutes in the standard programme	231
Noise in the Cottons programme with full load in db(A) re 1 pW	62
Condensation efficiency class	A

TQ 1000 WP Nova Edition
 T2 heat-pump dryer
 9 kg | M Touch Pro | QuickPowerDry | SteamCare | WoolDry



EAN: 4002516860921 / Material number: 12699270 /
 Old Material Number: 12Q10001GB

Energy consumption in kWh in the Cottons Normal dry
 standard programme with a full load 1.44

EcoFeedback	•
EcoDry technology	•
Maintenance-free heat exchanger	•
ProfiEco motor	•
EcoSpeed	•
Wash programmes	
Down filled items/Duvets	•
Drying programmes	
Automatic	•
Cottons (coloureds)	•
Cottons arrow	•
ECO	•
Minimum iron	•
Delicates	•
Silks handcare	•
Woollens handcare	•
Woollens	•
Express	•
Denim	•
Outerwear	•
Proofing	•
Sportswear	•
Cool air	•
Warm air	•
Basket programme	•
Smoothing	•
Bed linen	•
Shirts/Blouses	•
QuickPowerDry	•
QuickHygiene	•
PowerFresh	•
Drying extras	
Anti-crease	•
Gentle tumble	•
Buzzer	•
DryCare 40	•
Favourites	•
Save energy	•
Pre-ironing	•
Quality	
Soft ribs	•
Safety	
Safety lock	•
PIN-Code	•
Empty out container indicator	•
Clean filter indication	•
Optical interface	•

TQ 1000 WP Nova Edition
 T2 heat-pump dryer
 9 kg | M Touch Pro | QuickPowerDry | SteamCare | WoolDry

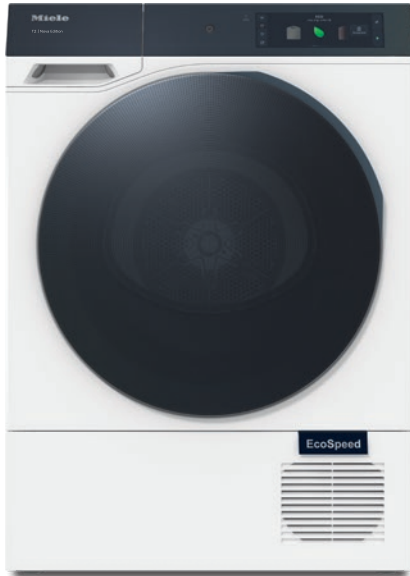

EAN: 4002516860921 / Material number: 12699270 /
 Old Material Number: 12Q10001GB

Technical data	
Dimensions in mm (width)	596
Dimensions in mm (height)	850
Dimensions in mm (depth)	643
Appliance depth in mm with opened door	1110
Weight in kg	55
Total rated load in kW	1.45
Voltage in V	220-240
Fuse rating in A	13
Frequency in Hz	50
Length of supply lead in m	2.0
Hermetically sealed	•
Type of coolant	R290
Refrigerant quantity in kg	0.14
Refrigerant global warming potential in CO ₂ e	3
Appliance global warming potential in CO ₂ e	0.44
Replacing lamps	Service
Accessories included	
Fragrance flacon	•
Voucher for a second fragrance flacon	•

TQ 1000 WP Nova Edition
T2 heat-pump dryer
9 kg | M Touch Pro | QuickPowerDry | SteamCare | WoolDry

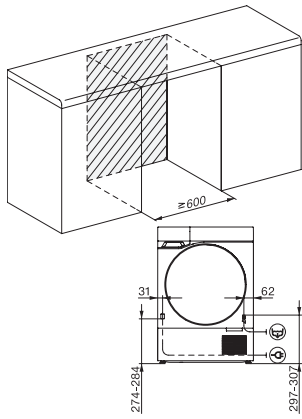

T2 drawing, facia 17 degree, measures in mm

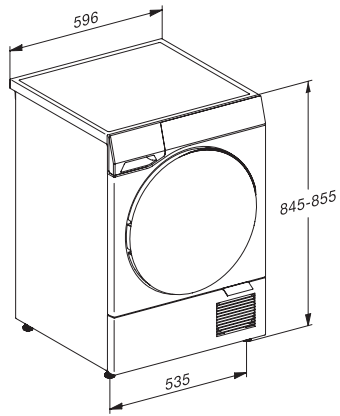

T2 drawing, facia 17 degree, measures in mm

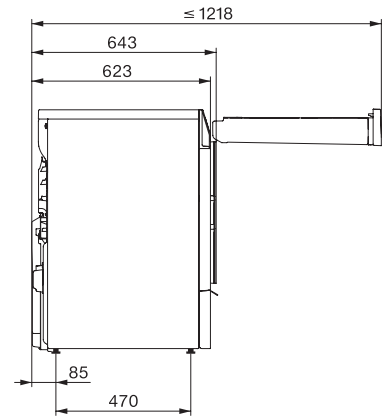

T2 drawing, facia 17 degree, with QuickPowerDry, measures in mm

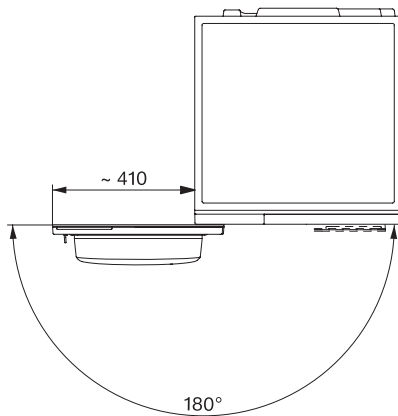

T2 drawing, facia 17 degree, with QuickPowerDry, measures in mm