

WCDO20 WPS 8kg

W1 front-loader washing machine:

A | 8 kg | 1400 rpm | Pre-ironing | CapDosing | honeycomb drum



- Tested for 20 years of perfect laundry care\*
- Save energy in the best energy efficiency class (A)
- The Pre-ironing Extra reduces creasing, saving up to 50 % time and effort\*\*
- Exclusive CapDosing range for different fabrics and stains\*\*\*
- Our honeycomb drum ensures that laundry stays in perfect condition

\* During the development phase of the W1 washing machine series, Miele tested models and core components in 5000 wash loads (= 5 wash loads per week for 50 weeks per year) in various programmes. More: [miele.com/20years](http://miele.com/20years)

\*\* Patent EP 2 088 231

\*\*\* Patent EP 2 365 120



EAN: 4002516849179 / Material number: 12693550 /  
Old Material Number: 11CDO203GB

<b>Construction type</b>	
Suitable for stacking	•
Side-by-side	•
Slot-in	•
Can be built-under	•
Door hinge	right
<b>Model</b>	
Product brand	W1 Chrome Edition
Front-loader	•
<b>Spinning</b>	
Max. spin speed	1400
Rinse hold	•
Without spin function	•
<b>Design</b>	
Appliance colour	Lotus white
Control panel colour	Lotus white
Door design	Lotus white
Rotary selector colour	Lotus White
Control panel version	Straight
Control type	Rotary control
Display	DirectSensor yellow, 7 segment
<b>Cleaning performance</b>	
CapDosing portioned dispensing	•
<b>Gentle laundry care</b>	
Honeycomb drum	•
Load in kg	8.0
<b>User convenience</b>	
Delay start up to 24 hours	•
Time left display	•
AutoClean detergent drawer	•
AddLoad	•
<b>Efficiency and sustainability</b>	
Energy efficiency class (A–G)	A
Weighted energy consumption per 100 operating cycles for the wash cycle in kWh	47
Weighted water consumption per cycle in l	47
Spin efficiency class	B
Acoustic airborne noise emission class (spin cycle)	A
Sound emissions during spin cycle in dB(A) re 1 pW	72
Duration of the "ECO 40–60" programme at nominal capacity	219
Power rating in off mode in W	0.30
Low temperature wash "Cold" and "20 °C"	•
Automatic load control	•
Foam sensing	•
ProfiEco motor	•

WCD020 WPS 8kg

W1 front-loader washing machine:

A | 8 kg | 1400 rpm | Pre-ironing | CapDosing | honeycomb drum



EAN: 4002516849179 / Material number: 12693550 /

Old Material Number: 11CD0203GB

<b>Wash programmes</b>	
Cottons (coloureds)	•
Minimum iron	•
Delicates	•
Shirts	•
Woollens (hand-washable)	•
Express 20	•
Dark garments / Denim	•
Outerwear	•
Proofing	•
Separate rinse/Starch	•
Drain / Spin	•
ECO 40-60	•
<b>Washing extras</b>	
Short	•
Pre-wash	•
Water plus	•
Additional rinse cycle	•
Pre-ironing with steam	•
Buzzer	•
<b>Safety</b>	
Water protection system	Watercontrol-System
Safety lock	•
PIN-Code	•
<b>Technical data</b>	
Dimensions in mm (width)	596
Dimensions in mm (height)	850
Dimensions in mm (depth)	636
Appliance depth in mm with opened door	1054
Appliance depth excluding door (for building-under) in mm	600
Weight in kg	80
Total rated load in kW	2.10-2.40
Voltage in V	220-240
Fuse rating in A	13
Frequency in Hz	50
Length of water inlet hose in m	1.60
Length of water drain hose in m	1.50
Length of supply lead in m	2

WCD020 WPS 8kg

W1 front-loader washing machine:

A | 8 kg | 1400 rpm | Pre-ironing | CapDosing | honeycomb drum

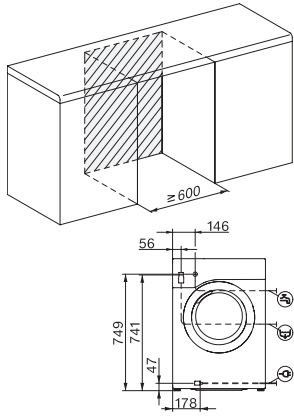

W1 installation drawing, slanted fascia or straight fascia, measures in mm



W1 drawing, slanted fascia or straight fascia, measures in mm



W1 drawing, slanted fascia or straight fascia, measures in mm

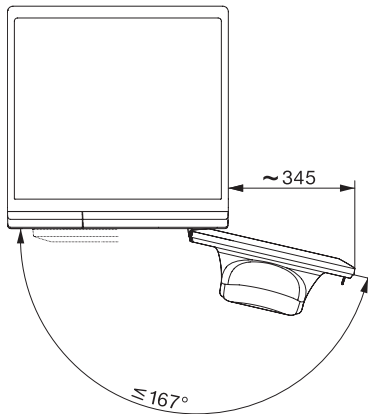

W1 drawing, slanted fascia or straight fascia, measures in mm