

FNS 7740 D

Built-in freezer

with NoFrost and 8 freezer drawers on telescopic runners for max. convenience.



- No icing up of food and no need to defrost thanks to NoFrost
- Optimum and maintenance-free LED lighting in compartment
- Clever networking opens up new possibilities – Miele@home
- Food is frozen quickly and gently – SuperFreeze
- Soft closing of the door with SoftClose



EAN: 4002516721840 / Material number: 12387660 / Old Material Number: 37774040GB

| | |
|----------------------------------------------------------------|-------------|
| Appliance category | |
| Freezer | • |
| Construction type | |
| Built-in appliance | • |
| Integrated appliance | • |
| Door hinge | Left |
| Convertible door hinging | • |
| Side-by-side enabled | • |
| Design | |
| Freezer compartment lighting | LED |
| User convenience | |
| Networking with Miele@home | • |
| NoFrost | • |
| VarioRoom | • |
| SoftClose | • |
| Control system | |
| Operating concept | SensorTouch |
| Independent temperature regulation of fridge and freezer zones | No |
| SuperFreeze | • |
| No. of temperature zones | 1 |
| Sabbath mode | • |
| Party mode | • |
| Freezer/Freezer section | |
| Number of freezer drawers | 8 |
| Efficiency and sustainability | |
| Energy efficiency class (A–G) | D |
| Annual energy consumption in kWh | 189.80 |
| Energy consumption in 24 h in kWh | 0.52 |
| Safety | |
| Lock function | • |
| Acoustic door alarm | • |
| Acoustic temperature alarm | • |
| Optical door alarm | • |
| Optical temperature alarm | • |
| Power cut indication for freezer section | • |
| Technical data | |
| Niche width in mm min. | 560 |
| Niche width in mm max. | 570 |
| Niche height in mm min. | 1772 |
| Niche height in mm max. | 1788 |
| Niche depth in mm | 550 |
| Appliance width in mm | 559 |
| Appliance height in mm | 1770 |
| Appliance depth in mm | 546 |
| Weight in kg | 61.2 |
| Door hinge technology | Fixed door |
| Max. door front weight – refrigerator, in kg | 26 |
| Climate class | SN-T |
| 4* freezer compartment in l | 213 |

FNS 7740 D

Built-in freezer

with NoFrost and 8 freezer drawers on telescopic runners for max. convenience.



EAN: 4002516721840 / Material number: 12387660 / Old Material Number: 37774040GB

| | |
|----------------------------------------------|---------|
| Total usable capacity in l | 213 |
| Storage time in case of fault in h | 9 |
| Freezer capacity in kg/24 h | 12.00 |
| Acoustic airborne noise emission class (A–D) | B |
| Sound emissions in dB(A) re 1 pW | 33 |
| Current consumption (mA) | 1300 |
| Voltage in V | 220-240 |
| Fuse rating in A | 13 |
| Number of phases | 1 |
| Frequency in Hz | 50-60 |
| Length of supply lead in m | 2.2 |
| Replacing lamps | Service |
| Accessories included | |
| Ice cube tray | • |

FNS 7740 D

Built-in freezer

with NoFrost and 8 freezer drawers on telescopic runners for max. convenience.

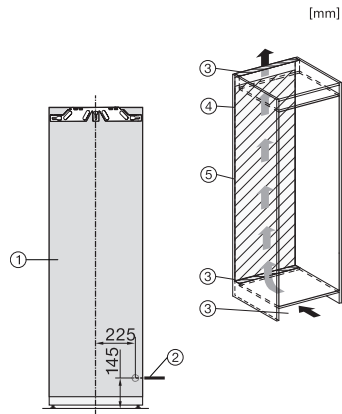

K7733E, K7763E, K7732E, K7734F, K7764E, K7743E, K7744E, K7773D, K7774D (footnote*) (installation drawings)

*1. View from the front, 2. Mains connection cable, L = 2100 mm, 3. Ventilation cut-out min. 200 cm², 4. Ventilation, 5. No connections permitted in this area

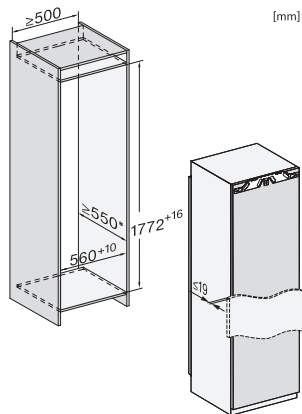

K7733E, K7763E, K7732D, K7732E, K7734F, K7764E, K7743E, K7744E, K7773D, K7774D, built-in (footnote*) (drawings)

*The declared energy consumption was calculated in a 560 mm deep niche. The appliance is fully functional in a 550 mm niche but the energy consumption will be slightly higher.

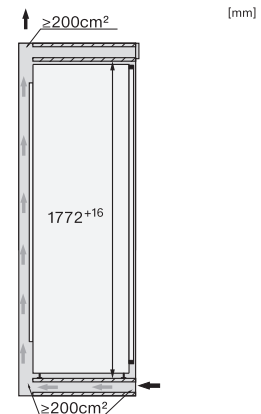

K7733E, K7763E, K7732E, K7734F, K7764E, K7743E, K7744E, K7773D, K7774D, side view (installation drawings)