

## KM 7629 FX

Induction hob with onset controls  
with TempControl for perfect frying results



- Intuitive quick selection via number sequences – Smart Select
- 5 cooking zones incl. 1 PowerFlex area and 1 TempControl zone
- A width of 928 mm for flush-fit installation
- Shortest heating-up times – TwinBooster
- Communication with the cooker hood – automatic Con@ctivity function

EAN: 4002516338376 / Material number: 11515520 / Old Material Number: 26762960GB

<b>Heating type</b>	
Heating type	Induction
<b>Construction type</b>	
Independent of cooker	•
<b>Design</b>	
Elegant glass ceramic surface	•
Flush	•
Ceramic surface colour	Black
<b>Cooking zone details</b>	
Number of cooking zones	5
Number of cooking areas	1
Maximum number of pans	5
<b>PowerFlex cooking zones</b>	
No.	2
Type	PowerFlex cooking zone
Diameter in mm	Ø 150 – 230
Rating in W	2100
Booster in W	3000
TwinBooster in W	3650
<b>1st cooking zone/cooking area</b>	
Position	front left
Type	Dual-circuit ring
Size in mm	Ø 100-160
Max. Booster power rating in W	1700
Max. rating in W	1400
Max. TwinBooster power rating in W	2200
<b>2nd cooking zone/cooking area</b>	
Position	rear left
Type	TempControl cooking zone
Size in mm	Ø 160-230
Max. Booster power rating in W	3000
Max. rating in W	2300
Max. TwinBooster power rating in W	3650
<b>3rd cooking zone/cooking area</b>	
Position	rear centre
Type	Dual-circuit ring
Size in mm	Ø 180-280
Max. Booster power rating in W	3000
Max. rating in W	2600
Max. TwinBooster power rating in W	3650
<b>4th cooking zone/cooking area</b>	
Position	right
Type	PowerFlex bridge
Size in mm	230x390
Max. Booster power rating in W	4800
Max. rating in W	3400
Max. TwinBooster power rating in W	7300
<b>User convenience</b>	
Miele@home	•
Operation via sensor controls	Smart Select

KM 7629 FX  
 Induction hob with onset controls  
 with TempControl for perfect frying results



EAN: 4002516338376 / Material number: 11515520 / Old Material Number: 26762960GB

Automatic function Con@ctivity 3.0	•
Pan and pan size recognition	•
Display colour	Yellow
Auto heat-up	•
Permanent pan recognition	•
Keeping warm	•
Stop & Go function	•
Recall function	•
TempControl	•
Safety switch-off	•
Keeping warm plus	•
Individual setting options (e.g. buzzers)	•
Wipe protection	•
Minute minder	•
<b>Efficiency and sustainability</b>	
Power rating in off mode in W	0.5
Power rating in standby mode in W	1.0
Power rating in networked standby in W	2.0
Time until automatic switch to off mode in min	20
Time until automatic switch to standby in min	20
Time until automatic switch to networked standby in min	20
<b>Cleaning and care</b>	
Easy to clean ceramic glass	•
<b>Safety</b>	
Safety switch-off	•
Lock function	•
System lock	•
Integrated cooling fan	•
Overheating protection	•
Residual heat indicator	•
<b>Technical data</b>	
Dimensions in mm (width)	928
Dimensions in mm (height)	51
Dimensions in mm (depth)	512
Casing height incl. connection box in mm	51
Internal cutout dimensions in mm (width) with flush installation	906
Internal cutout dimensions in mm (depth) with flush installation	490
Weight in kg	16
External cutout dimensions in mm (width) with flush installation	932
External cutout dimensions in mm (depth) with flush installation	516
Total rated load in kW	11.00
Length of supply lead in m	1.4
Voltage in V	230
Frequency in Hz	50-60
<b>Accessories included</b>	
Mains cable	Yes

KM 7629 FX  
Induction hob with onset controls  
with TempControl for perfect frying results

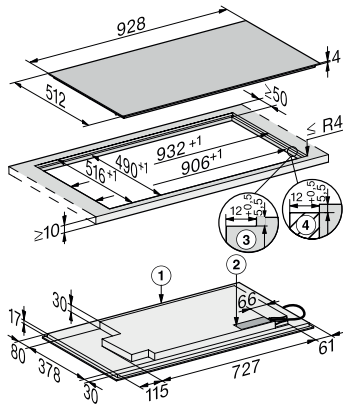

KM 7629 FX, flush (Installation drawing)

1) Front, 2) Mains connection box with mains connection cable, L = 1440 mm, 3) Stepped cut-out natural stone worktop, 4) Wood support 12 mm (not supplied)