

WCA030 WCS Active

W1 front-loader washing machine:

B | 7 kg | 1400 rpm | CapDosing | honeycomb drum | AddLoad



- Tested for 20 years of perfect laundry care
- ExclusiveCapDosing range for different textiles and stains
- Our honeycomb drum ensures that laundry stays in perfect condition
- Add or remove individual items during the wash cycle with AddLoad
- Freshen up laundry quickly with the Express 20 programme



EAN: 4002516303282 / Material number: 11456170 / Old Material Number: 11CA0301GB

Construction type	
Suitable for stacking	•
Side-by-side	•
Slot-in	•
Door hinge	right
Model	
Product brand	W1 Chrome Edition
Front-loader	•
Spinning	
Max. spin speed	1400
Rinse hold	•
Without spin function	•
Design	
Appliance colour	Lotus white
Control panel colour	Lotus white
Door design	Lotus white
Rotary selector colour	Lotus White
Control panel version	Slanted
Control type	Rotary control
Display	EasyControl yellow
Cleaning performance	
CapDosing portioned dispensing	•
Gentle laundry care	
Honeycomb drum	•
Load in kg	7.0
User convenience	
Delay start up to 24 hours	•
Time left display	•
AutoClean detergent drawer	•
AddLoad	•
Efficiency and sustainability	
Energy efficiency class (A–G)	B
Weighted energy consumption per 100 operating cycles for the wash cycle in kWh	51
Weighted water consumption per cycle in l	45
Spin efficiency class	B
Acoustic airborne noise emission class (spin cycle)	A
Sound emissions during spin cycle in dB(A) re 1 pW	72
Duration of the "ECO 40–60" programme at nominal capacity	199
Power rating in off mode in W	0.30
Low temperature wash "Cold" and "20 °C"	•
Automatic load control	•
Flow meter	•
Foam sensing	•
ProfiEco motor	•
Wash programmes	
Cottons (coloureds)	•
Cottons with pre-wash	•
Minimum iron	•

WCA030 WCS Active

W1 front-loader washing machine:

B | 7 kg | 1400 rpm | CapDosing | honeycomb drum | AddLoad



EAN: 4002516303282 / Material number: 11456170 / Old Material Number: 11CA0301GB

Delicates	•
Woolens (hand-washable)	•
Express 20	•
Dark garments / Denim	•
Outerwear	•
Proofing	•
Separate rinse/Starch	•
Drain / Spin	•
ECO 40-60	•
Washing extras	
Short	•
Soak	•
Water plus	•
Additional rinse cycle	•
Safety	
Water protection system	Watercontrol-System
Safety lock	•
PIN-Code	•
Optical interface	•
Technical data	
Dimensions in mm (width)	596
Dimensions in mm (height)	850
Dimensions in mm (depth)	636
Appliance depth in mm with opened door	1054
Appliance depth excluding door (for building-under) in mm	600
Weight in kg	80
Total rated load in kW	2.10-2.40
Voltage in V	220-240
Fuse rating in A	13
Frequency in Hz	50
Length of supply lead in m	2
Length of supply lead in m	2.0

WCA030 WCS Active

W1 front-loader washing machine:

B | 7 kg | 1400 rpm | CapDosing | honeycomb drum | AddLoad



W1 installation drawing, slanted fascia or straight fascia, measures in mm

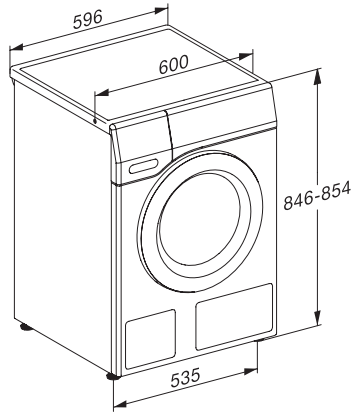

W1 drawing, slanted fascia or straight fascia, measures in mm



W1 drawing, slanted fascia or straight fascia, measures in mm

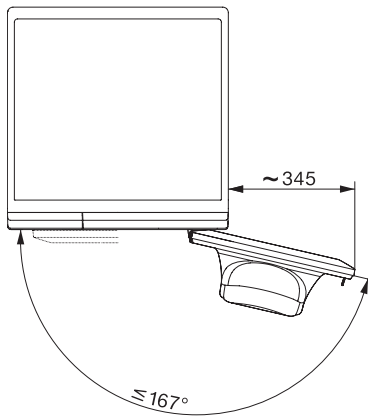

W1 drawing, slanted fascia or straight fascia, measures in mm