

EVS 7010

Handleless built-in vacuum drawer, 14 cm high
for professional vacuum packing of food.



- Remains fresh for longer – storage and portioning of food
- Intense taste – marinating food
- Preparation of food for sous-vide cooking
- Easy handling – Touch controls and fully telescopic runners
- Opening the drawer couldn't be easier – Push2open

EAN: 4002516131618 / Material number: 11093430 / Old Material Number: 30701031GB

Construction type and design	
Built-in vacuum sealing drawer	•
VitroLine	•
ArtLine	•
Handleless	•
Colour	Graphite grey
Convenience features	
Preparing food for sous-vide cooking	•
Longer storage life of food	•
Marinating food	•
Operating modes	
Vacuum sealing	•
Range of applications	
Vacuum sealing food	•
Marinating food	•
Dividing food into portions	•
Vacuum sealing containers	•
Resealing original packaging	•
Sealing jars	•
Vacuum sealing liquids	•
User convenience	
Stainless steel vacuum sealing chamber capacity in l	8.0
Minimum bag size in mm	250
Maximum bag size in mm	350
Push2open mechanism	•
Fully telescopic runners for easy loading and unloading of the warming drawer	•
Control panel with sensor controls	•
Control panel with symbols	•
Vacuumping strength min. in steps	1
Max. vacuum settings	3
LED vacuum setting indicator	•
Vacuumping strength min. for external containers in steps	1
Max. vacuum settings for external containers	3
LED vacuum setting indicator	•
Sealing duration settings	1 - 3
LED sealing duration indicator	•
Stop function	•
Vacuum-sealing technology	
Stainless-steel vacuum chamber	•
Pump capacity in m ³ /h	4
Cleaning and care	
Flush control panel	•
Note regarding moisture removal from the vacuum pump	•
Replaceable sealing bar	•
Safety	
Safety switch-off	•
Technical data	
Appliance width in mm	595
Appliance height in mm	141

EVS 7010

Handleless built-in vacuum drawer, 14 cm high
for professional vacuum packing of food.



EAN: 4002516131618 / Material number: 11093430 / Old Material Number: 30701031GB

Appliance depth in mm	570
Useable interior height in mm	80
Total rated load in kW	0.32
Voltage in V	230
Frequency in Hz	50-60
Fuse rating in A	10
Number of phases	1
Mains cable with plug	•
Length of supply lead in m	1.8
Accessories included	
Adapter for vacuum-sealing container	1
Vacuum sealing bag support	1
Vacuum sealing bags	•
Number of vacuum sealing bags 180 x 280 mm	50
Number of vacuum sealing bags 240 x 350 mm	50

EVS 7010

Handleless built-in vacuum drawer, 14 cm high
for professional vacuum packing of food.

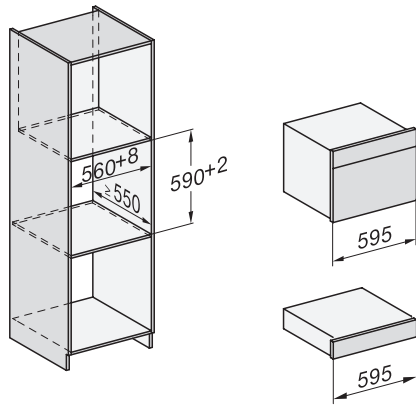

ESW7x10, DGC7x4xHCPro, DGC7x4xHCXPro, installation drawings

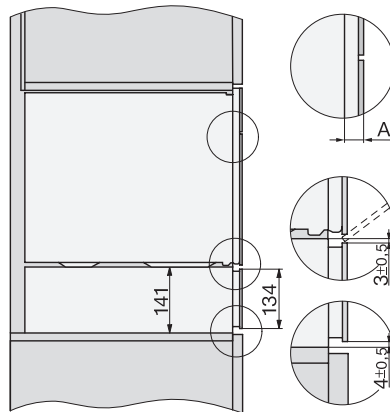

ESW7x10, EVS7010, DG7x4x, DGM7x4x installation drawings

A) 22 mm glass, 23,3 mm stainless steel

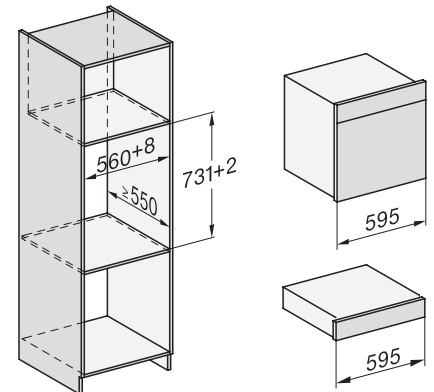

ESW7x10, EVS7010, DGC7x6xHCPro, DGC7x6xHCXPro installation drawings

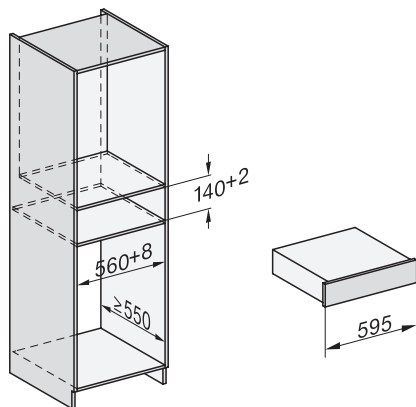

built-in ESW7x10 EVS7010, installation drawing

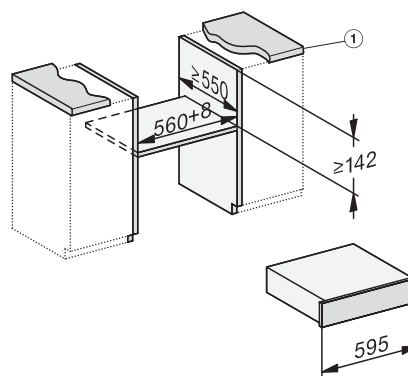

built-in EVS 7010 build-under, installation drawing

1) Countertop overhang ≤ 29mm

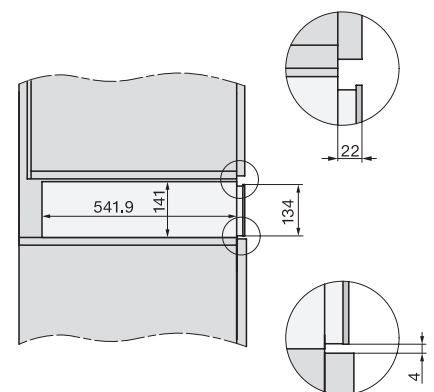

side view ESW7x10 EVS7010, installation drawing, GB, AU

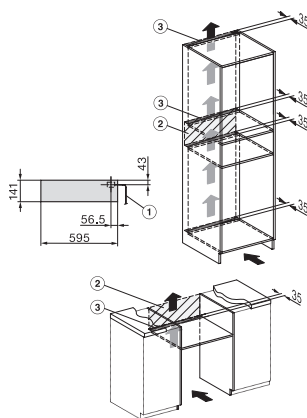

installation EVS7010 installation drawing, GB, AU

1) Mains connection cable, L=2000 mm, 2) No connection in this area, 3) Ventilation cutout min. 180 cm²