

KFN 28132 D edt/cs
 Freestanding fridge-freezer
 with Frost free and Dynamic cooling for highest convenience and versatility.



- Optimum and maintenance-free LED lighting in compartment
- No icing up of food and no need to defrost thanks to Frost free
- Handle-less design thanks to an integrated handle design



EAN: 4002515812075 / Material number: 10622070 / Old Material Number: 38281321EU1

Appliance category	
Fridge-freezer	•
Construction type	
Freestanding appliance	•
Door hinge	right
Convertible door hinging	•
Design	
Casing colour	Stainless steel look
Front colour	Stainless steel/CleanSteel
Refrigeration section lighting	LED
User convenience	
ComfortClean	•
DynaCool	•
NoFrost	•
DuplexCool	•
VarioRoom	•
Concealed door opener	Recessed grip
Control system	
Operating concept	PicTronic
Fridge compartment can be switched off	Yes
Independent temperature regulation of fridge and freezer zones	Yes
SuperFreeze	•
No. of temperature zones	2
Sabbath mode	•
QuickCool Timer	•
Fridge/Fridge section	
No. of shelves	4
Number of inner door racks for tinned food	2
Door rack for bottles	1
Door shelves	3
Freezer/Freezer section	
Number of freezer drawers	3
Efficiency and sustainability	
Energy efficiency class (A–G)	E
Annual energy consumption in kWh	246.01
Energy consumption in 24 h in kWh	0.67
Safety	
Lock function	•
Acoustic door alarm	•
Acoustic temperature alarm	•
Optical temperature alarm	•
Technical data	
Appliance width in mm	600
Appliance height in mm	1861
Appliance depth in mm	657
Weight in kg	65.0
Climate class	SN-T
Refrigerator compartment in l	209
4* freezer compartment in l	101

KFN 28132 D edt/cs
 Freestanding fridge-freezer
 with Frost free and Dynamic cooling for highest convenience and versatility.



EAN: 4002515812075 / Material number: 10622070 / Old Material Number: 38281321EU1

Total usable capacity in l	310
Storage time in case of fault in h	12
Freezer capacity in kg/24 h	8.00
Acoustic airborne noise emission class (A–D)	C
Sound emissions in dB(A) re 1 pW	40
Current consumption (mA)	1400
Voltage in V	220-240
Fuse rating in A	10
Number of phases	1
Frequency in Hz	50
Length of supply lead in m	2.4
Replacing lamps	Service
Accessories included	
Egg tray	•
Ice cube tray	•

KFN 28132 D edt/cs
 Freestanding fridge-freezer
 with Frost free and Dynamic cooling for highest convenience and versatility.

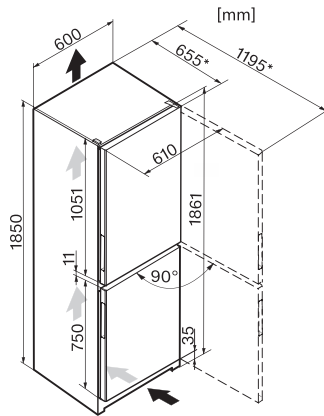

KFN28132D ws, KFN28133D ws, KFN28132D edt/cs,
 KFN28133D edt/cs (Skizze) (*Fußnote)

*To ensure that energy consumption as stated is achieved, machines should be used together with the enclosed spacer brackets. This increases the total depth of the unit by approx. 3.5 cm. , Machines are still fully functional when operated without these brackets but have a slightly higher energy consumption.,

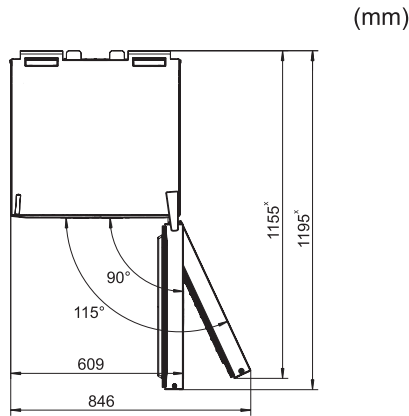

KFN28132D ws, KFN28133D ws, KFN28132D edt/cs,
 KFN28133D edt/cs, KFN29132, KFN29133, (Skizze)
 (*Fußnote)

*To ensure that energy consumption as stated is achieved, machines should be used together with the enclosed spacer brackets. This increases the total depth of the unit by approx. 3.5 cm. , Machines are still fully functional when operated without these brackets but have a slightly higher energy consumption.,