

THE BENCHMARK MACHINES



PDR 944 | 100 lbs. PERFORMANCE PLUS

Features

- Programmable controls
- Short program cycles
- Patented Honeycomb Drum
- PerfectDry system – residual moisture sensors
- Intelligent dryers – gentle and uniform
- Perfect anti-crease
- Economical and efficient
- LAN/WiFi capable (accessory required)



Gas Heating



Steam Indirect



Hot Water Heating



Electric Heating

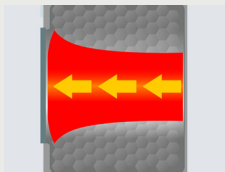

Axial airflow

For perfect drying results, air is passed through the drum according to the principle of longitudinal air flow.

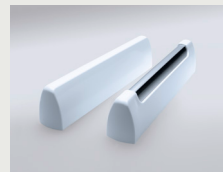

SoftLift drum ribs ensure gentle fabric care

The SoftLift drum ribs allow laundry to be dried gently and evenly.

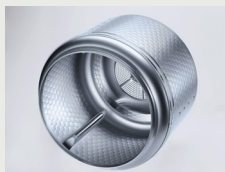

Honeycomb Drum

Less folding, easy finishing: laundry is dried very gently and evenly in the Honeycomb Drum.



Large fluff filter

The very large filter surface is particularly easy to clean.

Model	Heat Type	Electrical Specification Voltage/Hz/Phase (Amp)	Color	Material No.	Article No.
PDR 944	Gas	208, 240/60/3 (3 x 15 A)	Iron Grey	12012460	52944028NAM
PDR 944	Gas	208, 240/60/3 (3 x 15 A)	Stainless Steel	12012450	52944027NAM
PDR 944	Steam	208, 240/60/3 (3 x 15 A)	Iron Grey	12012430	52944024NAM
PDR 944	Steam	208, 240/60/3 (3 x 15 A)	Stainless Steel	12012420	52944023NAM
PDR 944	Hot Water	208, 240/60/3 (3 x 15 A)	Stainless Steel	12012440	52944025NAM
PDR 944	Electric	208, 240/60/3 (3 x 150 A)	Stainless Steel	12012400	52944019NAM
PDR 944	Electric	440, 480/60/3 (3 x 70 A)	Stainless Steel	12012410	52944021NAM

Specifications

Capacity	100 lbs. (45 kg)
Cylinder Diameter	20 1/2 in. (520 mm)
Cylinder Depth	34 1/2 in. (876 mm)
Cylinder Volume	28.3 cu.ft. (800 l)
Machine Dimensions (WxDxH)	47 1/2 x 54 1/2 x 64 9/16 in. (1,206 x 1,385 x 1,640 mm)
Door Opening	24 13/16 in. (630 mm)
Floor to Door	27 15/16 in. (710 mm)
Reversible Door	Yes
Shipping Dimensions (WxDxH)	54 3/4 x 58 x 69 1/2 in. (1,390 x 1,474 x 1,766 mm)
Net Weight Gas Steam	651 lbs. (295.3 kg) 720 lbs. (326.3 kg)
Hot Water EL	720 lbs. (326.3 kg) 649 lbs. (294.3 kg)
Crated Weight Gas Steam	691 lbs. (313 kg) 759 lbs. (344 kg)
Hot Water EL	759 lbs. (344 kg) 688 lbs. (312 kg)
Min. Recommended Distance Between Machines	13/16 in. (20 mm)
Agency Approvals	Intertek

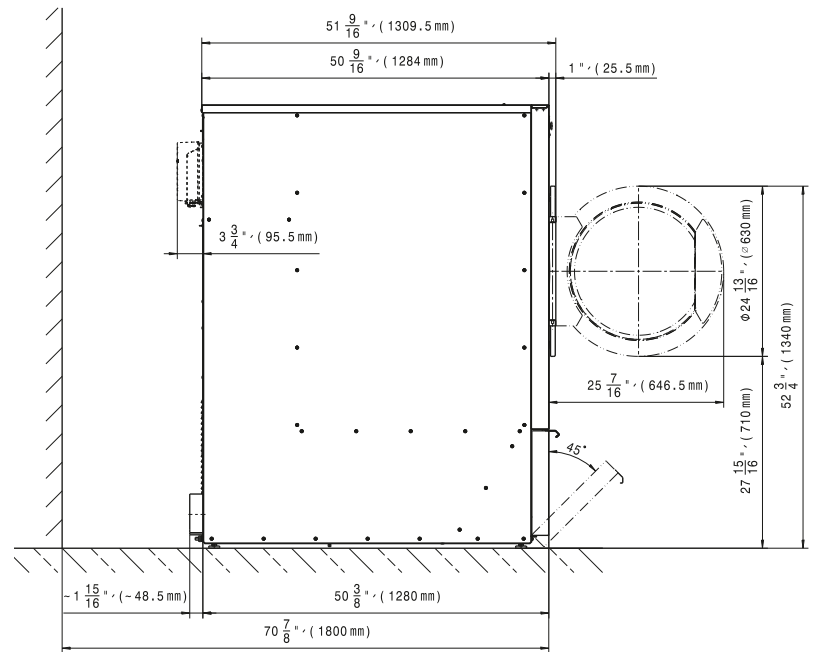
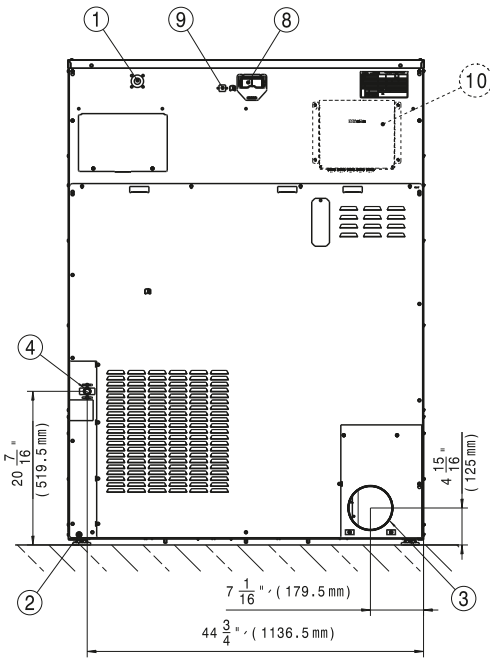
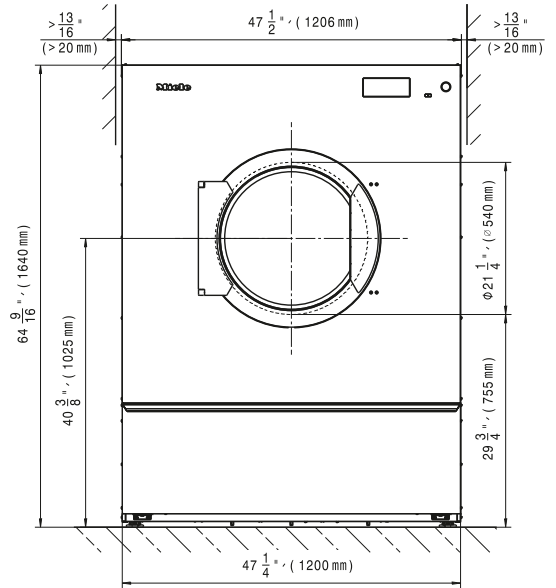

Heating	Voltage (Voltage/Hz/Phase)	Wire	Circuit Breaker Amps	Running Amps	Total Power (kW)
Gas	208, 240/60/1	2 Wire + Ground	15	10	1.7
Steam	208, 240/60/1	2 Wire + Ground	15	10	1.7
Hot Water	208, 240/60/1	2 Wire + Ground	15	10	1.7
Electric	208, 240/60/3	3 Wire + Ground	150	100.9	40.9
Electric	440, 480/60/3	3 Wire + Ground	70	54.6	44.1

Specifications subject to change without notice or obligation.
Contact Miele USA at (800) 991-9380 or Miele Canada at
(888) 325-3957 for dimensions not shown or for clarification.