

de - Montageplan für vollintegrierte Geschirrspüler

Bitte beachten Sie diesen Montageplan und lesen Sie unbedingt die Gebrauchsanweisung vor der Aufstellung - Installation - Inbetriebnahme.
Dadurch schützen Sie sich und vermeiden Schäden an Ihrem Gerät.

en - Installation drawings for fully integrated dishwashers

To avoid the risk of accidents or damage to the dishwasher please observe this installation sheet and read the operating instruction manual supplied with it before it is installed or used for the first time.

el - Σχεδιάγραμμα τοποθέτησης για πλήρως εντοιχίζόμενα πλυντήρια πιάτων

Λάβετε υπόψη σας αυτό το σχεδιάγραμμα τοποθέτησης και διαβάστε οπωσδήποτε τις οδηγίες χρήσης, πριν από την τοποθέτηση - σύνδεση - αρχική λειτουργία. Έτσι προστατεύετε τον εαυτό σας και αποφεύγετε πιθανές βλάβες στη συσκευή.

hr - Načrt za montažu potpuno integrirane perilice posuđa

Prije postavljanja - ugradnje - prve uporabe obavezno pročitajte upute za uporabu i pridržavajte se načrta za montažu.
Time ćete zaštititi sebe i izbjeći oštećenja uređaja.

ro - Plan de instalare pentru mașini de spălat vase complet integrate

Pentru a evita riscul de accidentare și avarierea mașinii, vă rugăm să respectați acest plan de instalare și să citiți Instrucțiunile de utilizare înainte de a instala, pune în funcțiune și utiliza mașina pentru prima dată.

sl - Montažni načrt za pomivalni stroj za skrito vgradnjo

Pred namestitvijo in prvo uporabo pomivalnega stroja morate najprej prebrati priložena navodila za uporabo in tako preprečiti poškodbe ljudi in pomivalnega stroja.

sr - Plan za montažu potpuno integriranih mašina za pranje sudova

Molimo Vas pridržavajte se ovog plana ugradnje i obavezno pročitajte uputstvo za upotrebu pre nego što mašinu postavite - ugradite - pustite u rad.
Na taj način ćete zaštititi sebe i izbjeći štete na Vašem uređaju.

bg - Схема за вграждане на съдомиялна машина за пълно вграждане

Моля, обърнете внимание на този монтажен чертеж и задължително прочетете ръководството за употреба преди поставяне - монтаж - пускане в експлоатация.
Така ще се предпазите и ще предотвратите щети.

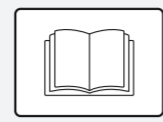

Gebrauchsanweisung beachten.

See operating instruction manual.

Διαβάστε τις οδηγίες χρήσης.

Pridržavajte se uputa za uporabu.

Consultați Instrucțiunile de utilizare.

Preberite navodila za uporabo.

Pridržavajte se uputstva za upotrebu.

Spazujte rukovodstvo za upotrebu.



Beschädigung oder Brandgefahr.

Risk of damage or fire hazard.

Κίνδυνος ζημιάς ή φωτιάς.

Opasnost od oštećenja ili požara.

Pericol de avarie sau de incendiu.

Nevarnost škode ali požara.

Postoji opasnost od oštećenja ili požara.

Повреда или опасност от пожар.



Anschlusswerte beachten.

Check connection data.

Προσοχή στην ισχύ ηλεκτρικής σύνδεσης.

Pridržavajte se priključnih vrijednosti.

Verificați parametrii de conectare la rețeaua electrică (tensiune, putere și frecvență).

Provjerite priključne vrijednosti uređaja.

Vodite računa o naponu, opterećenju i frekvenciji.

Проверете данните за електрическата връзка.

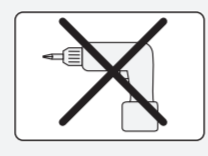

Keinen Akkuschrauber verwenden, Beschädigungsgefahr.

Do not use a cordless screwdriver, risk of damage.

Μη χρησιμοποιήσετε καταφιίδι Akku, κίνδυνος ζημιάς.

Nemojte koristiti akumulatorski odvijač, opasnost od oštećenja.

Nu folosiți o șurubelniță cu acumulator, pericol de deteriorare.

Ne uporabljajte akumulatorskega vijaka, opasnost poškodbe.

Ne koristiti akumulatorski odvijač, opasnost od oštećenja.

Ne използвайте акумулаторен винтоверт - опасност от повреда.



Vor dem Verschieben des Geschirrspülers FüÙe eindrehen.

Screw the feet in before moving the dishwasher.

Πριν μετακινήσετε το πλυντήριο πιάτων βιδώστε τα πόδια του.

Prije pomicanja perilice posuđa zavrnite nožice uređaja.

Înainte de deplasarea mașinii, înșurubați complet picioarele.

Noge privijte pred premikanjem pomivalnega stroja!

Pre pomeranja mašine za pranje sudova zavrnite nogice.

Преги преместване на съдомиялната машина навийте краката навътре.



Achtung Schnittgefahr.

Warning: Danger of being cut.

Προσοχή. Κίνδυνος τραυματισμού.

Ražnja: opasnost od posjekotina.

Atenție: Pericol de tăiere.

Ražnja: opasnost od posjekotina.

Внимание - опасност от нараняване.



Türfedern nach Montage der Frontplatte unbedingt auf beiden Seiten gleichmäßig einstellen.

The door springs must be set equally on both sides after fitting the front panel to the door.

Μετά την τοποθέτηση της διακοσμητικής πόρτας, ρυθμίσετε οπωσδήποτε τα ελατήρια πόρτας ομοιόμορφα και από τις δύο πλευρές της.

Nakon montaže prednje ploče, opruge vrata moraju biti ravnomjerno podešene na obje strane.

Arcurile ușii trebuie reglate în mod egal pe ambele părți după montarea panoului frontal al ușii.

Na obeh straneh uravnajte tečaj vrat.

Nakon montaže prednje ploče neophodno je ravnomerno podesiti šarke vrata sa obe strane.

След монтажа на предния декоративен панел задължително регулирайте пружините на вратата равномерно от двете страни.



Wasserablauf belüften

Wenn der bauseitige Anschluss für den Wasserablauf tiefer liegt als die Führung für die Rollen des Unterkorbes in der Tür, muss der Wasserablauf belüftet werden.

Venting the water drain

If the on-site drainage connection is situated lower than the guide path for the lower basket rollers in the open door, the drainage system must be vented.

Εξαερισμός αποχέτευσης νερού

Αν η σύνδεση για την εκροή του νερού στον χώρο εγκατάστασης βρίσκεται χαμηλότερα από τις πλαινές ράγες κύλισης του κάτω καλίστρου στην πόρτα, τότε το σύστημα εκροής νερού χρειάζεται εξαερισμό.

Prozračivanje odvoda vode

Ako je priključak kućne instalacije za odvod vode dublje postavljen od vodilice za kotačiće donje košare u vratima, odvod se mora ventilirati.

Aerisirea sistemului de scurgere

În cazul în care racordul scurgerii din locația de instalare este situat sub nivelul ghidajului roților coșului inferior din ușa deschisă, sistemul de scurgere trebuie aerisit.

Odzračevanje odtoka

Če priključek za odtok leži nižje od vodil za kolesca spodnje košare v vratih, je odtok treba prezračevati.

Provetravanje odvoda vode

Ako je postojeći priključak za odvod vode postavljen niže od vodica za točkice donje korpe na vratima, sistem za odvod vode mora da se provetri.

Обезвъздушаване на източването на вода

Ако връзката за източването на водата на място се намира пониско от водача във вратата за ролките на долната кошница, източването на водата трябва да се вентилира.

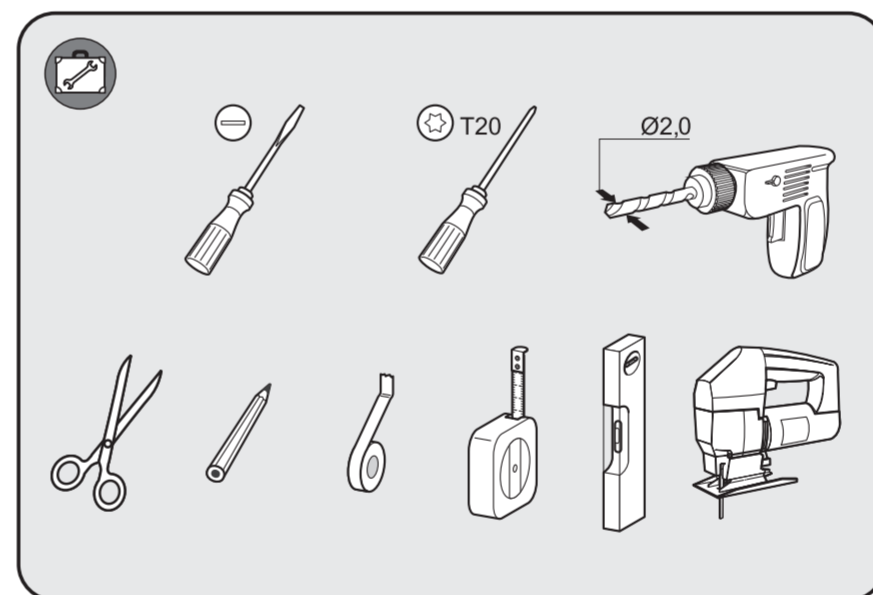
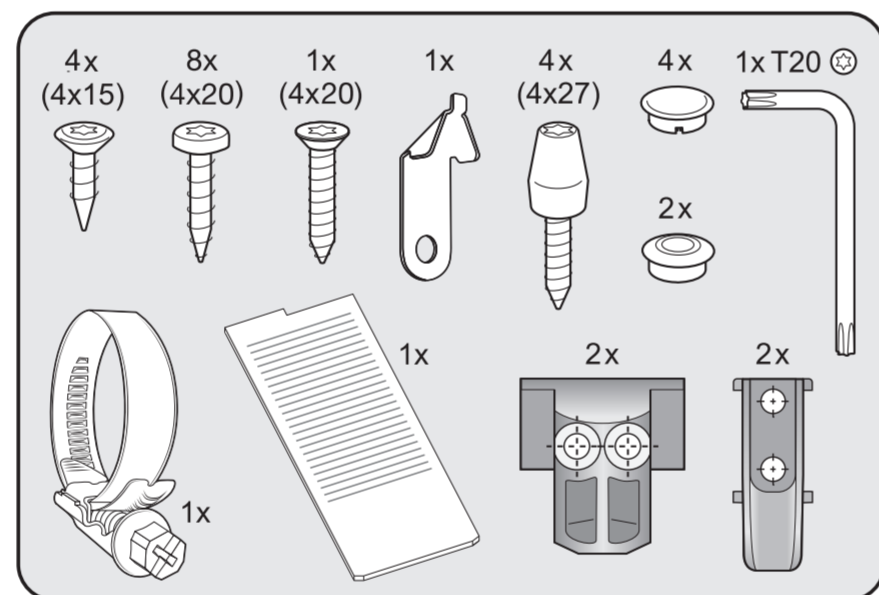
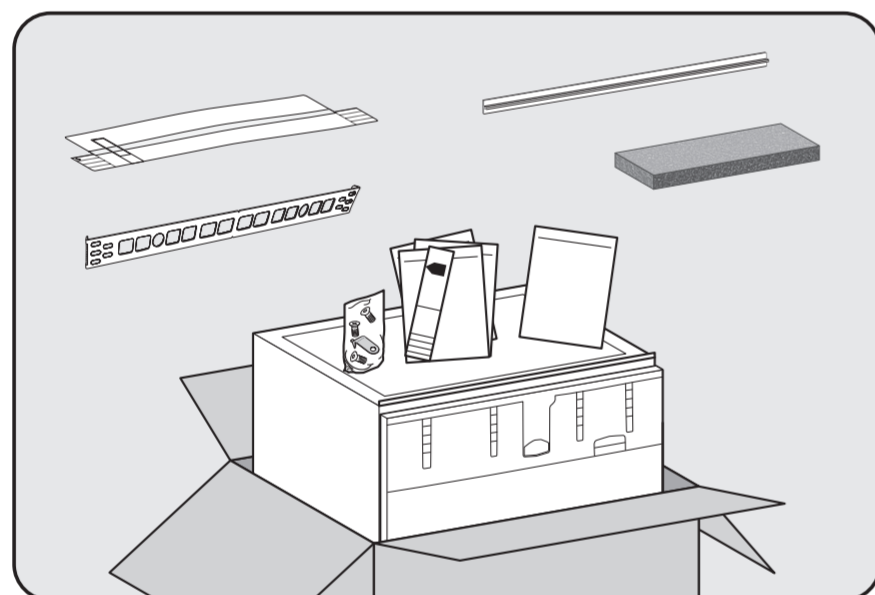
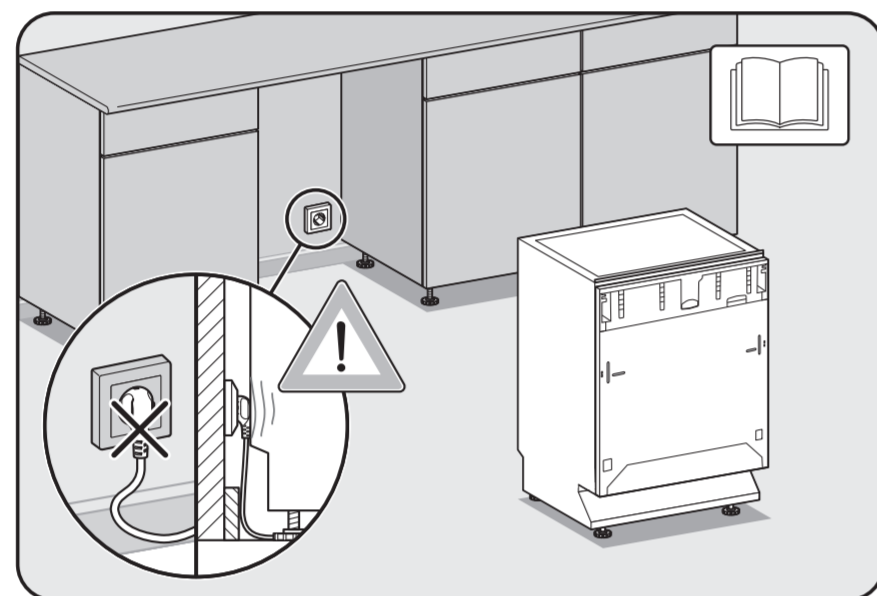

Je nach Modell benötigtes Werkzeug.
Tools required depend on model.
Απαραίτητα εργαλεία ανάλογα με το μοντέλο.
Potrebni alat ovisi o modelu.
Potrebne náradie v závislosti od modelu.
Potrebno orodje, odvisno od modela.
Potrebni alat, zavisno od modela.
Необходимите инструменти са в зависимост от модела.

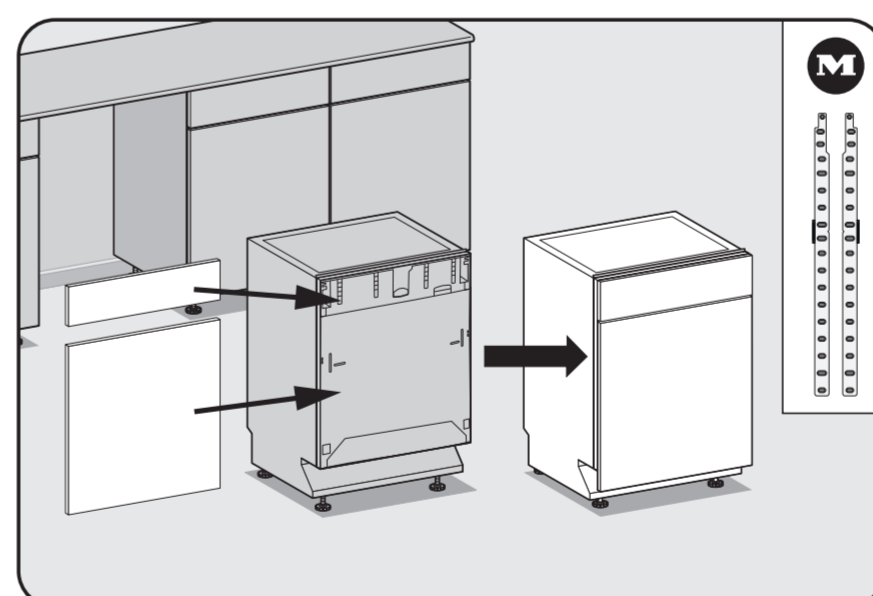
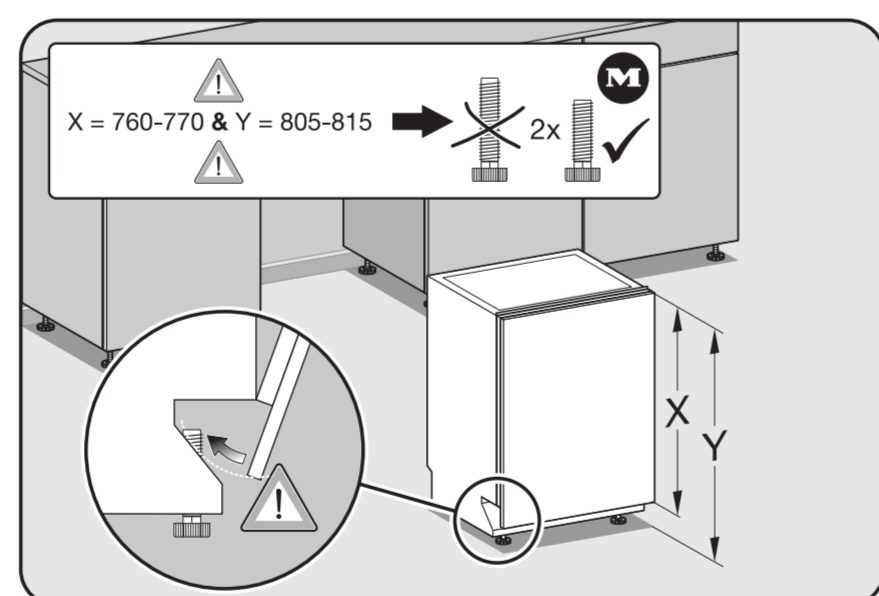
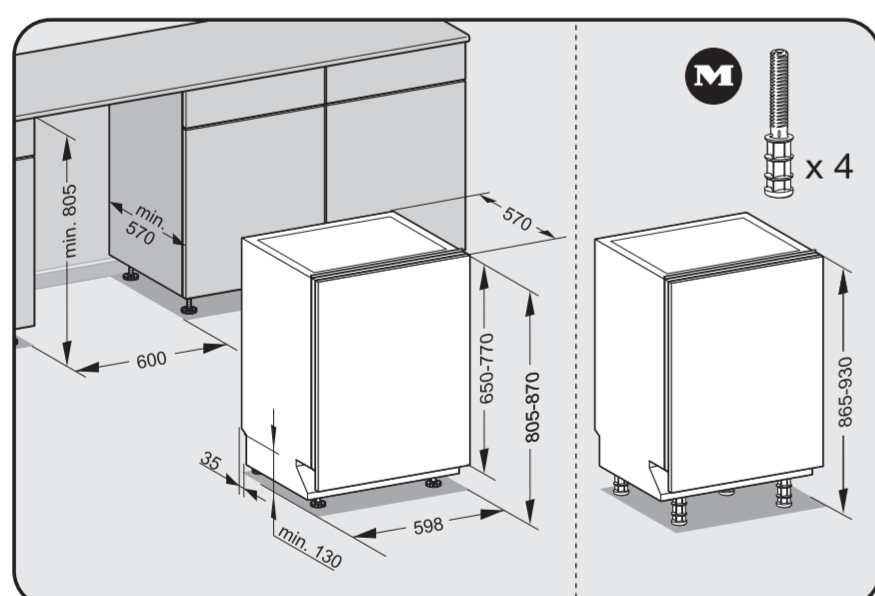

M Nachkaufbares Zubehör
Optional accessories
Προσθετο εξάρτητα
Dodatni pribor
Pribor koji možete naknadno kupiti
Accesorii opționale
Допълнително закупувана принадлежност

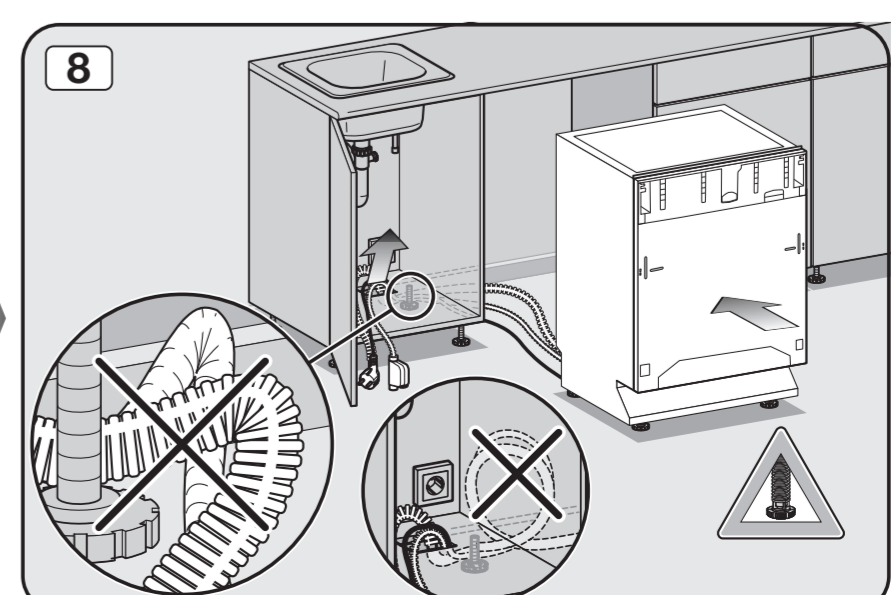
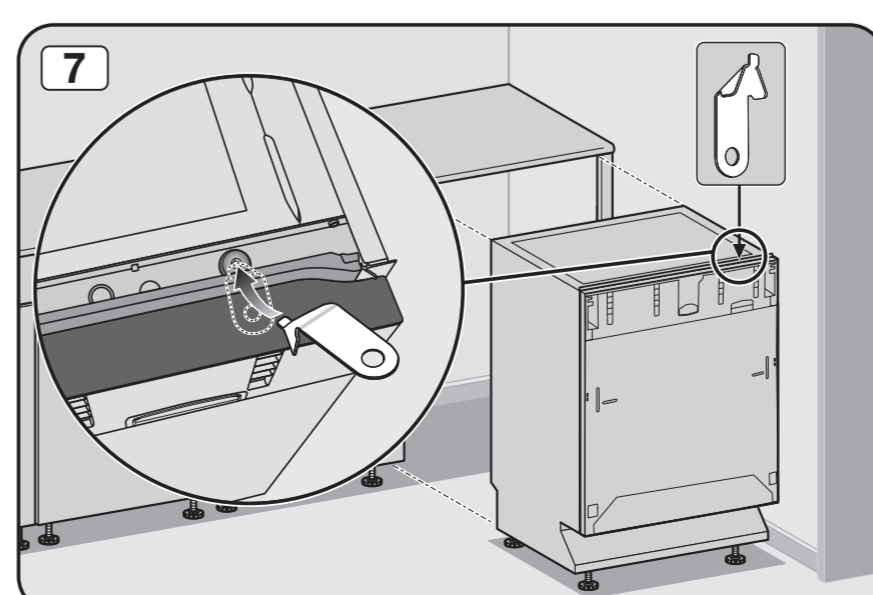
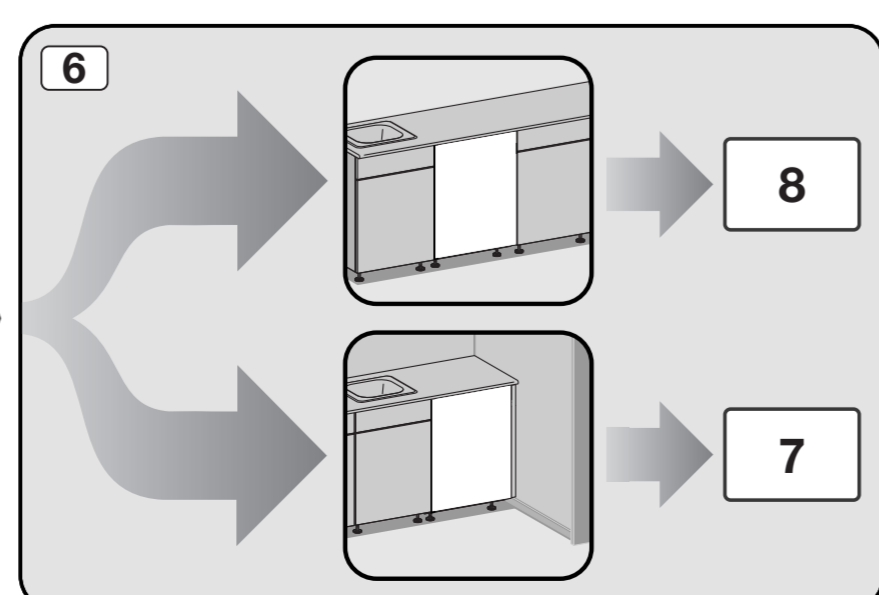
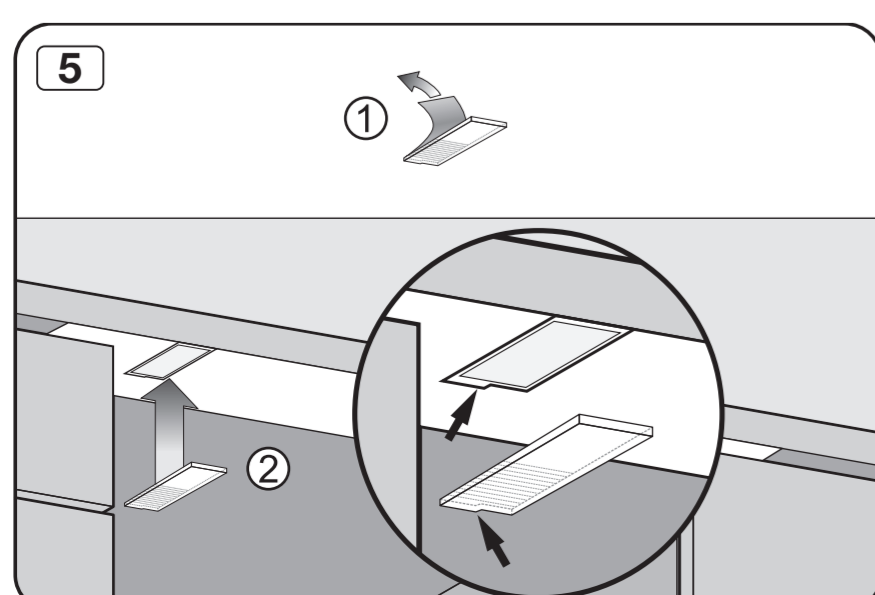
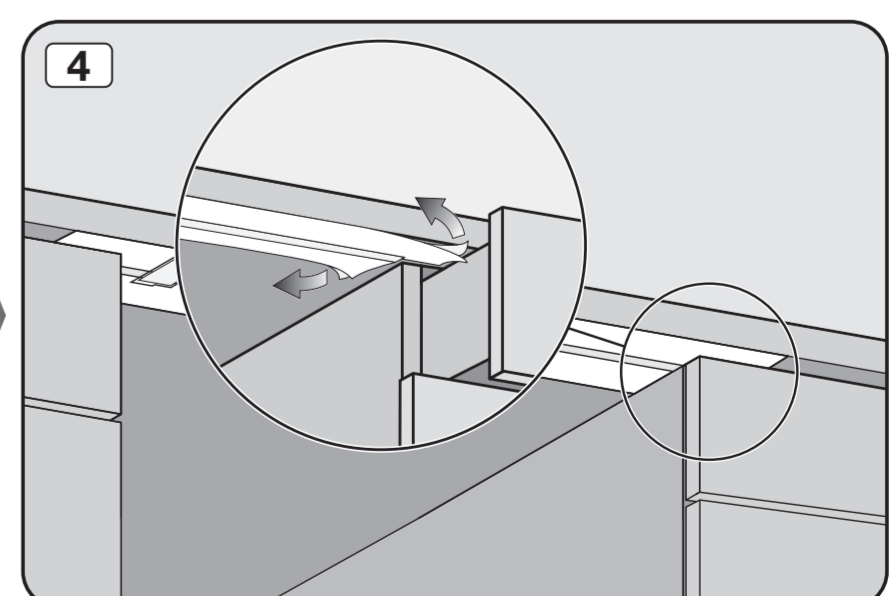
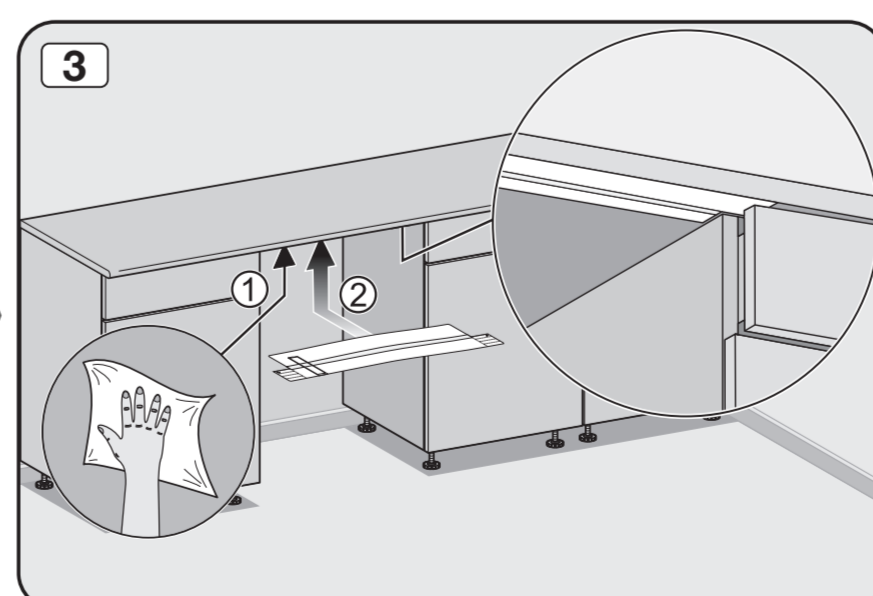
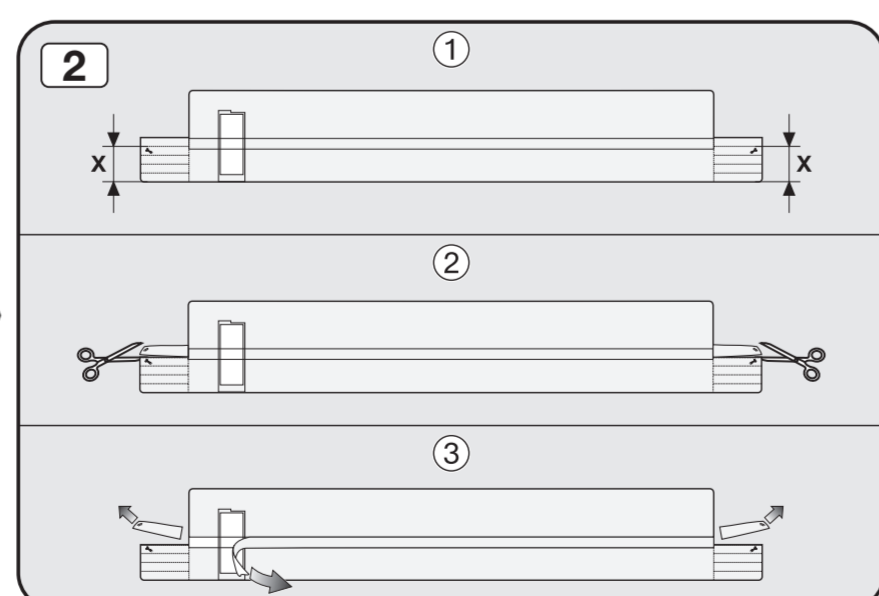
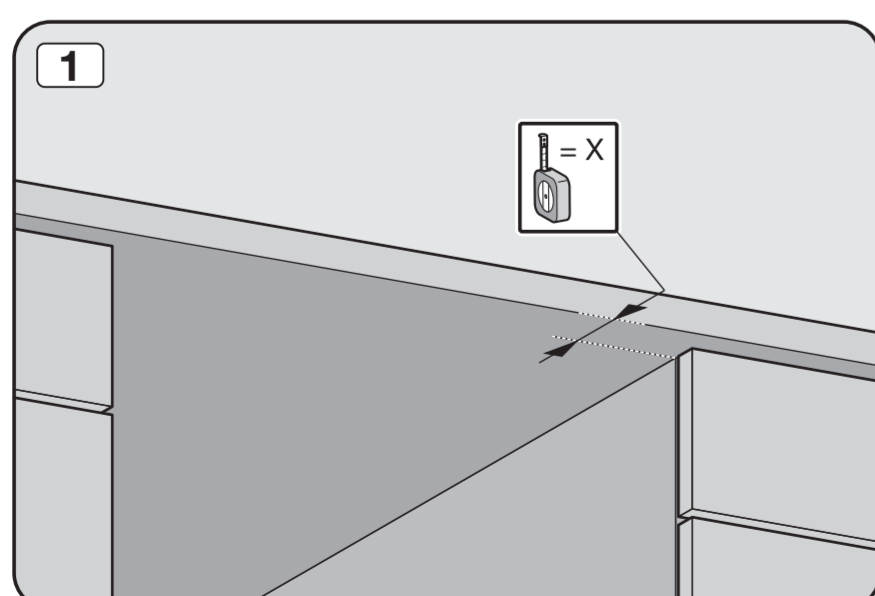

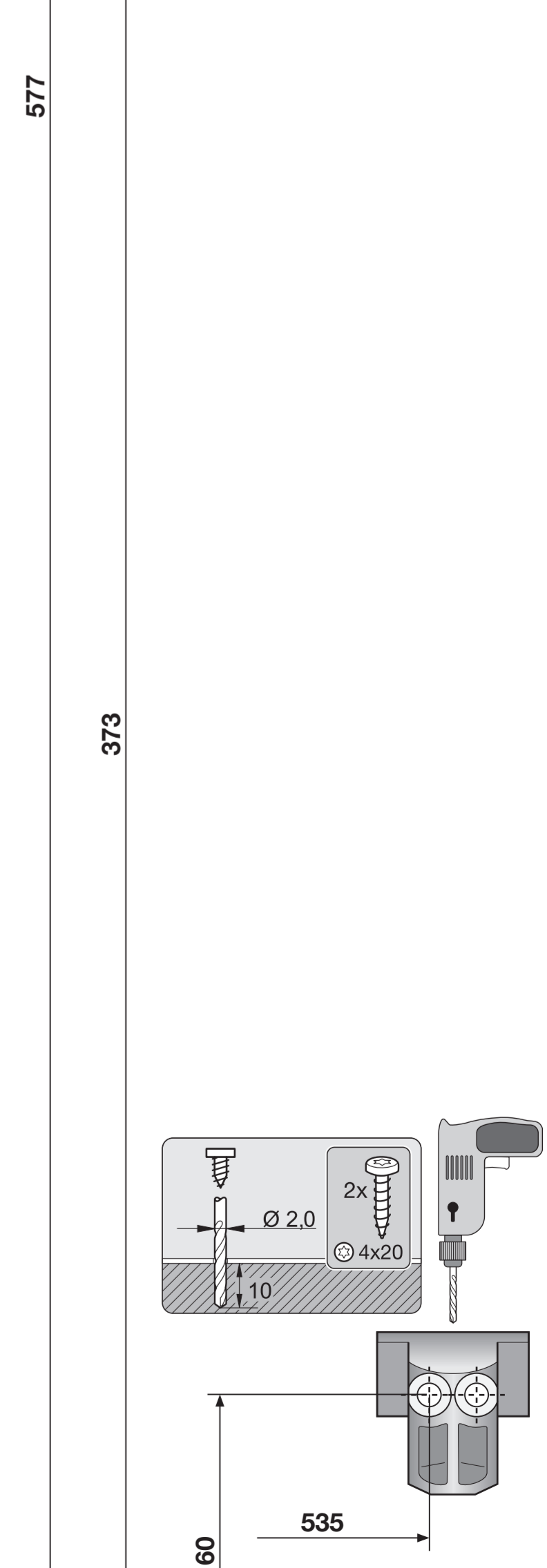
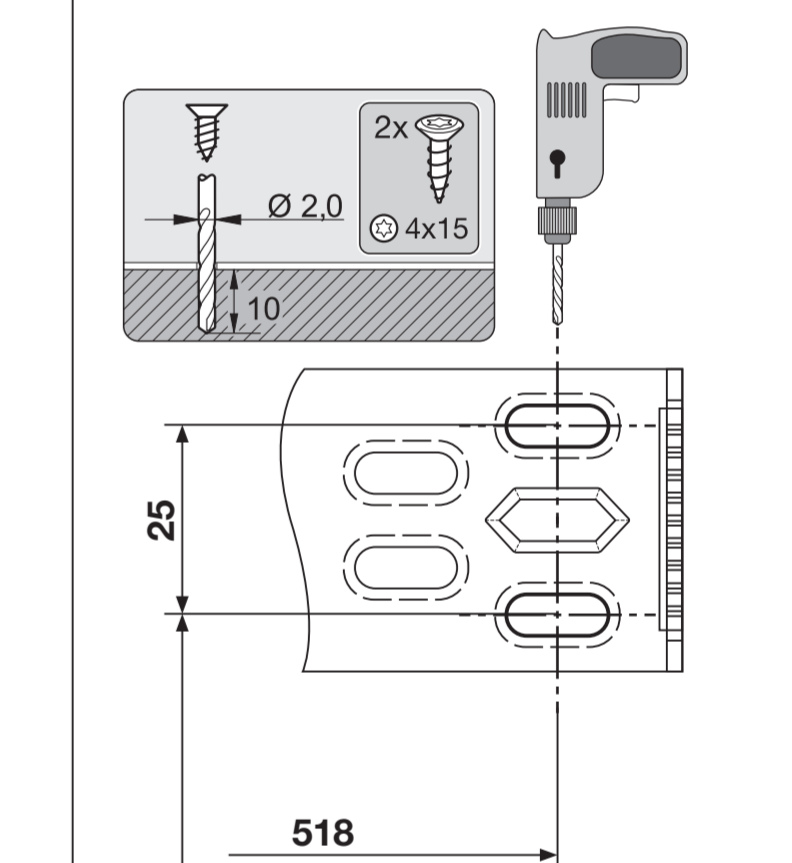
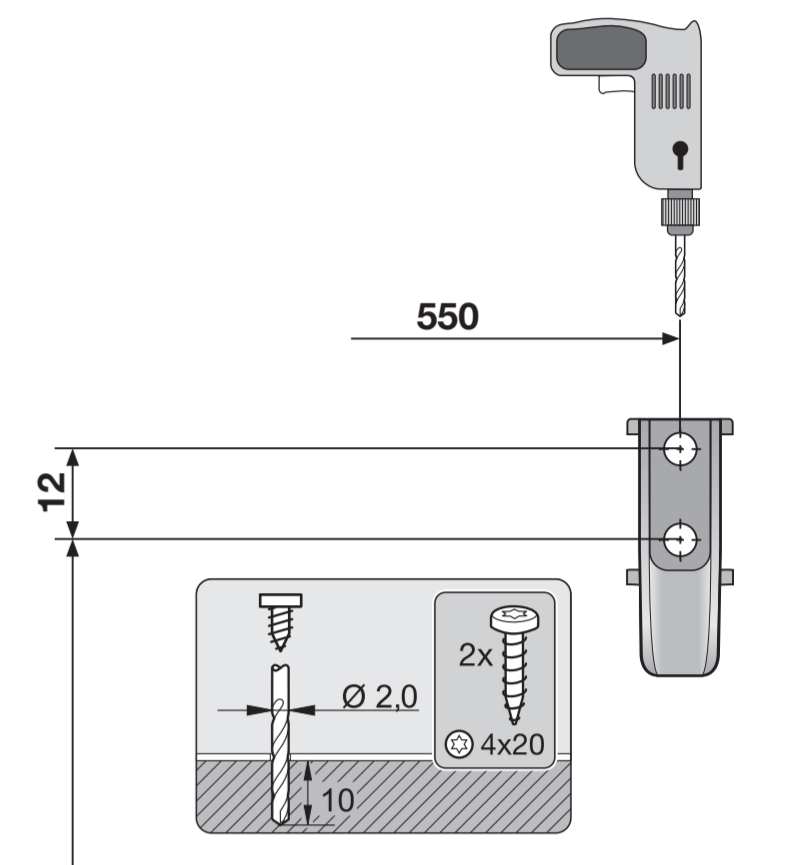
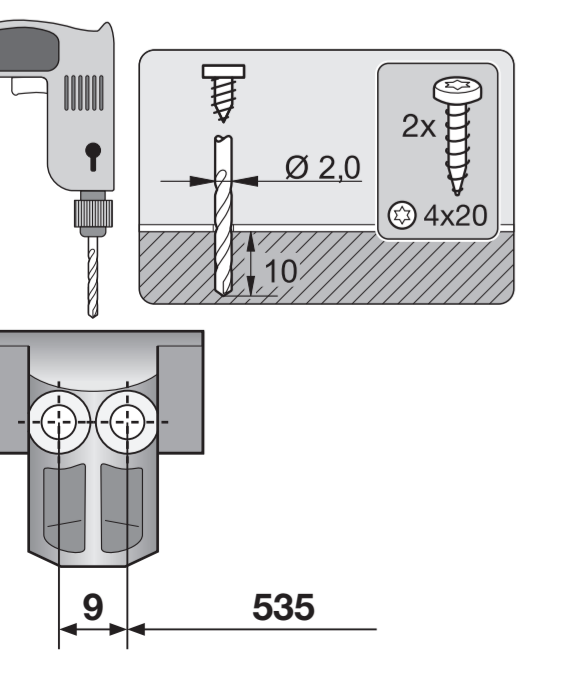
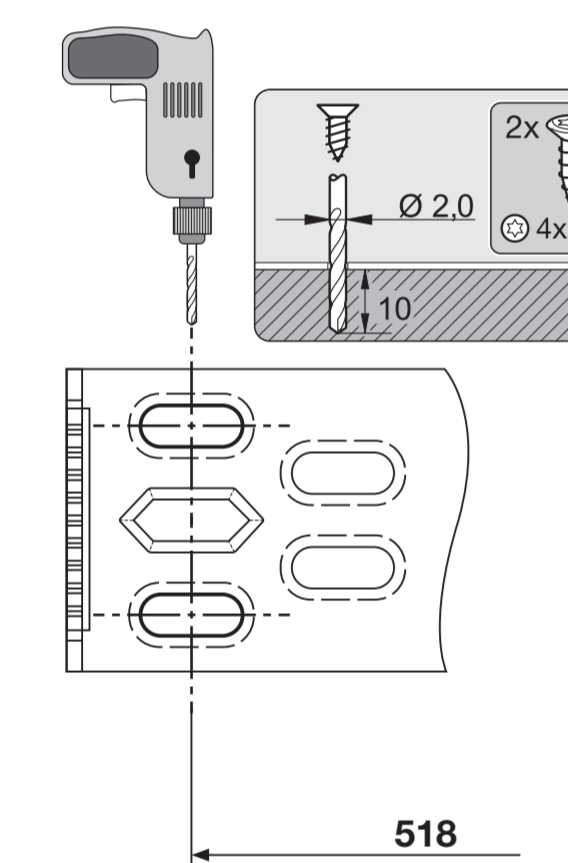
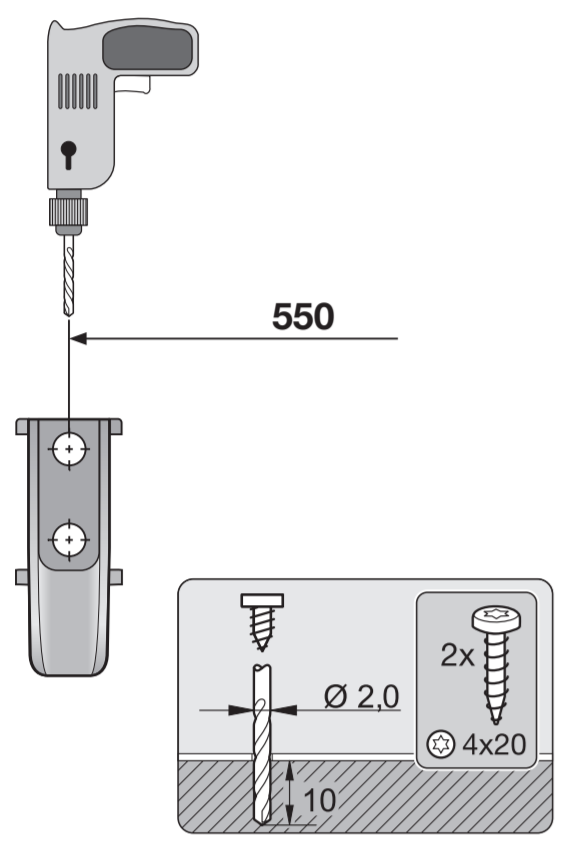
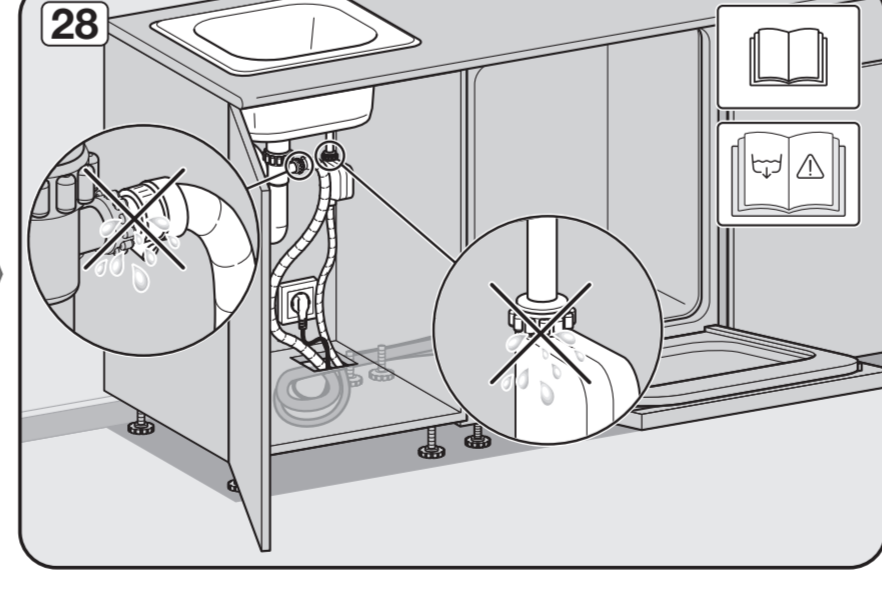
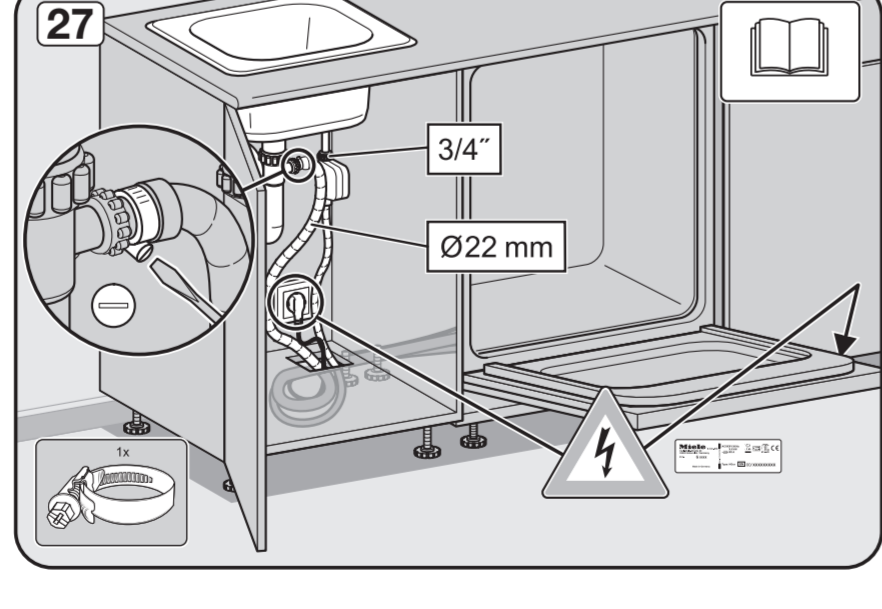
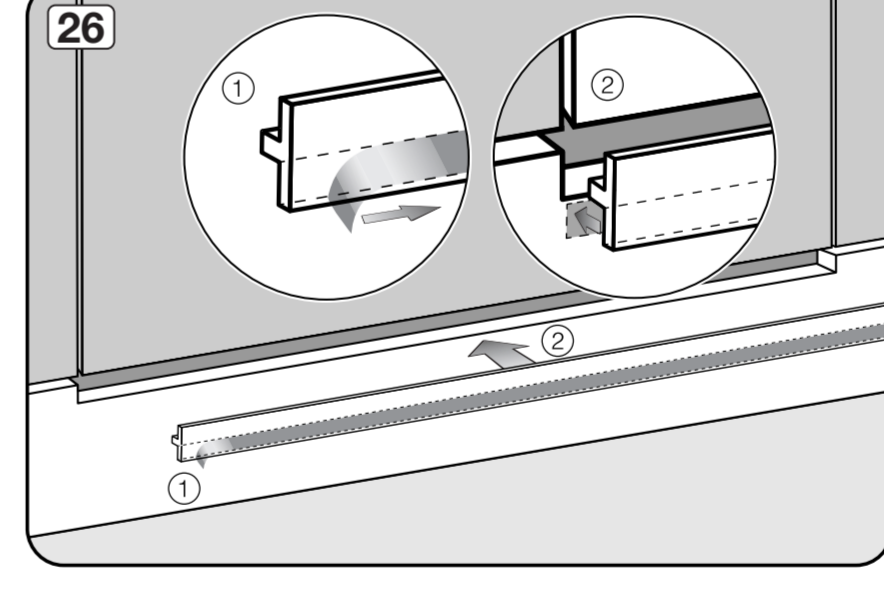
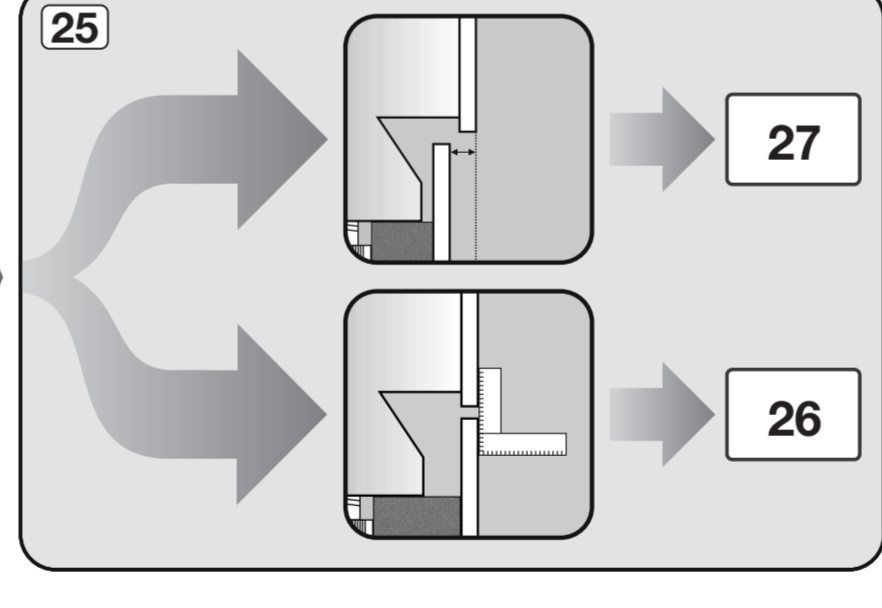
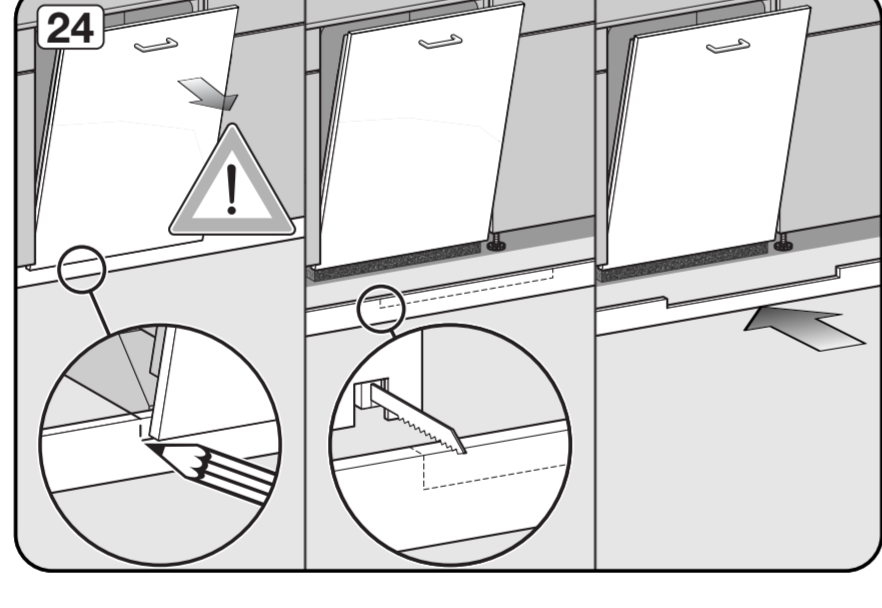
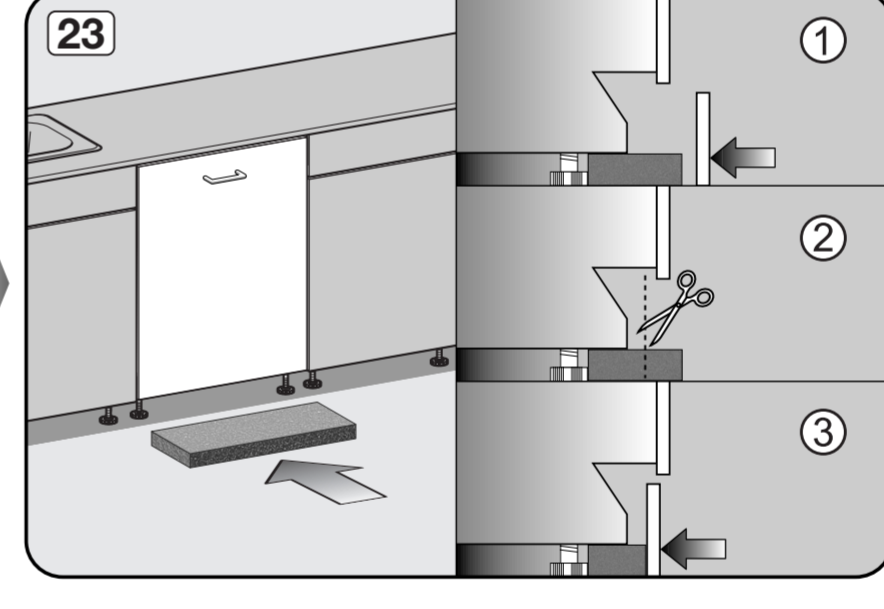
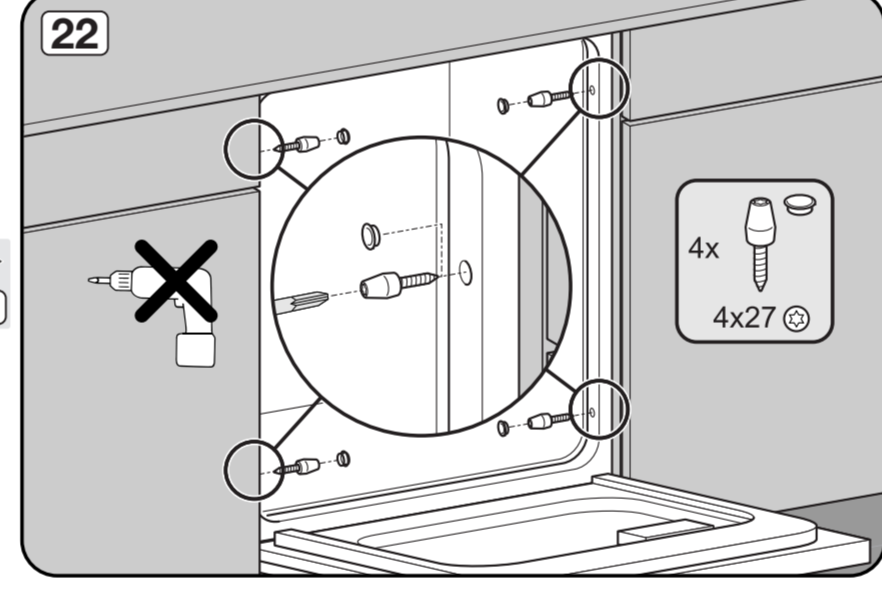
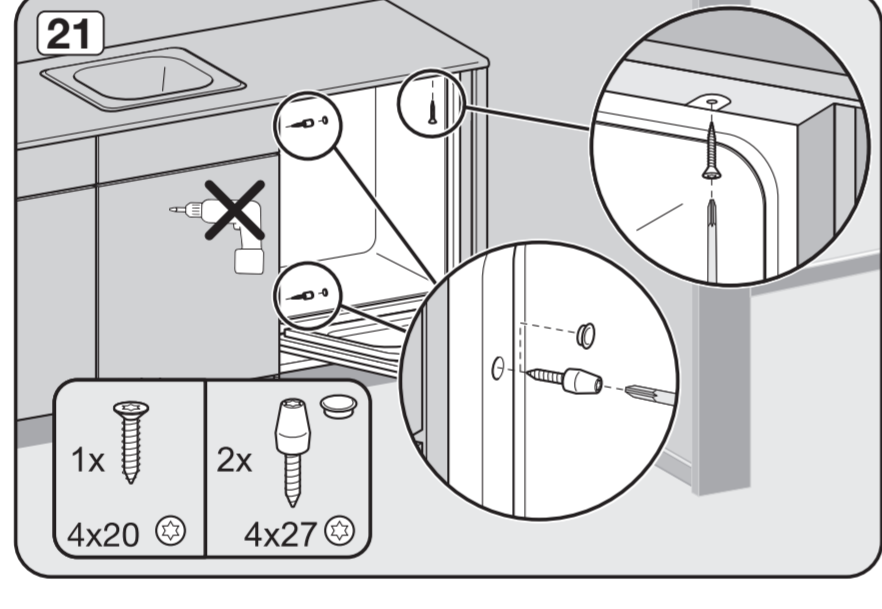
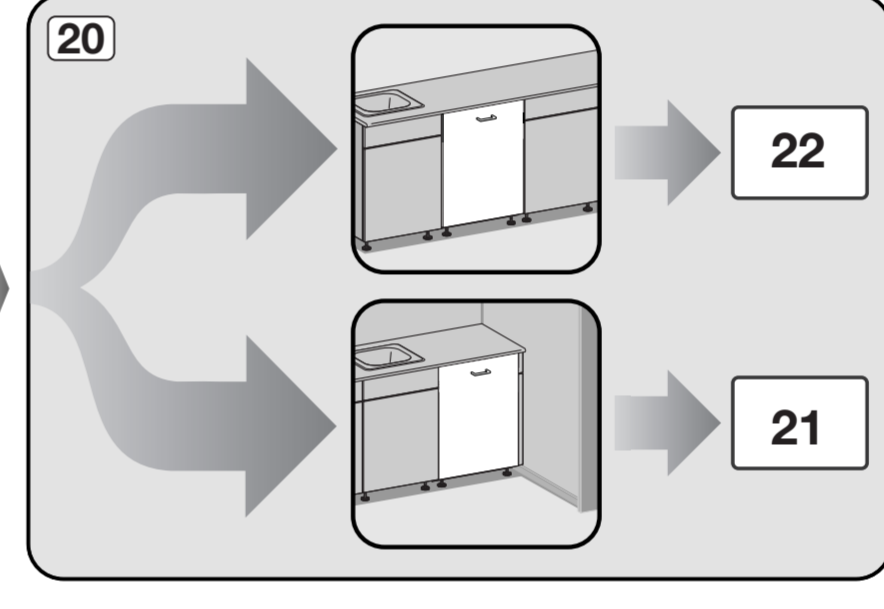
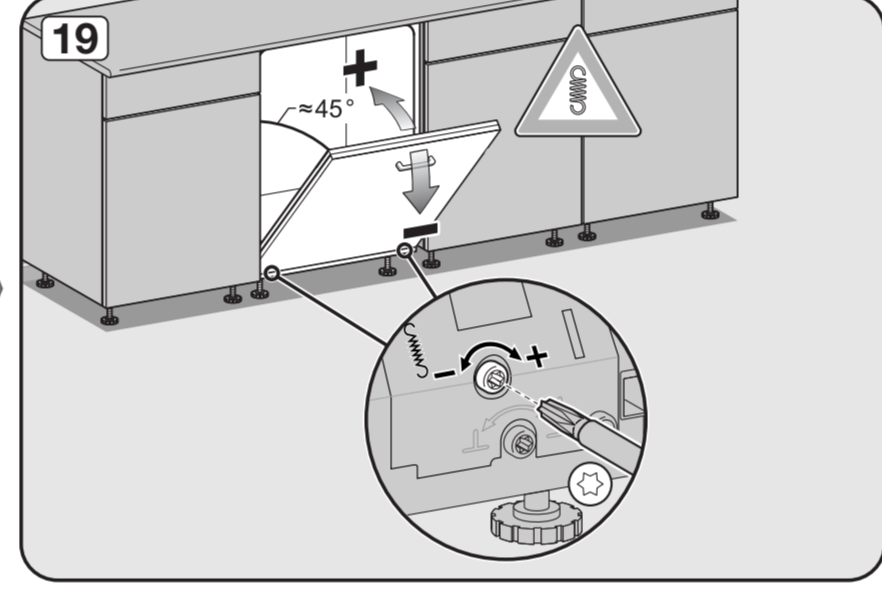
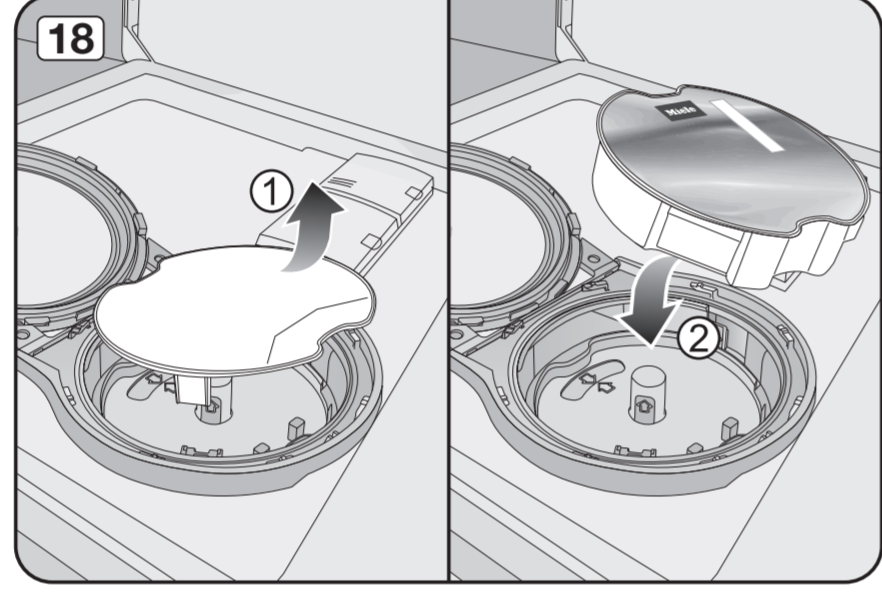
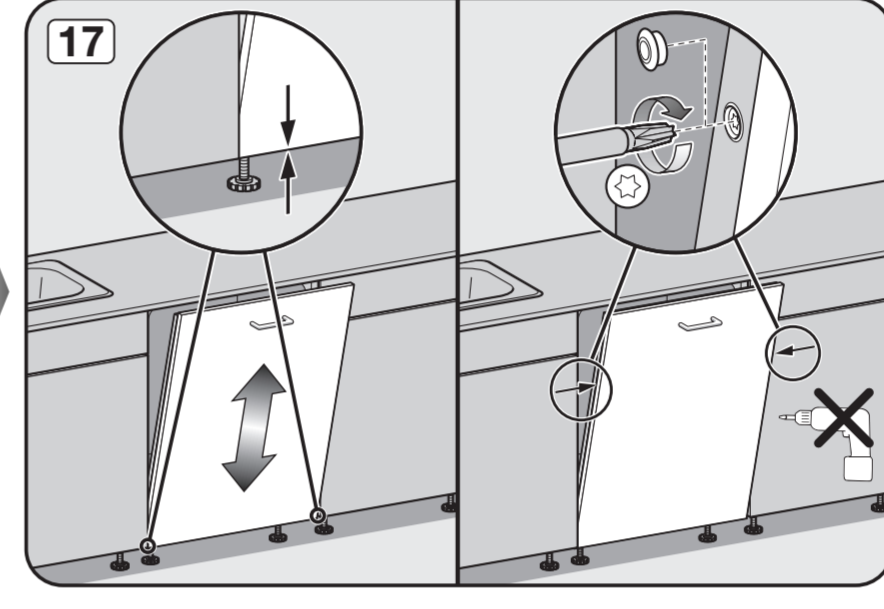
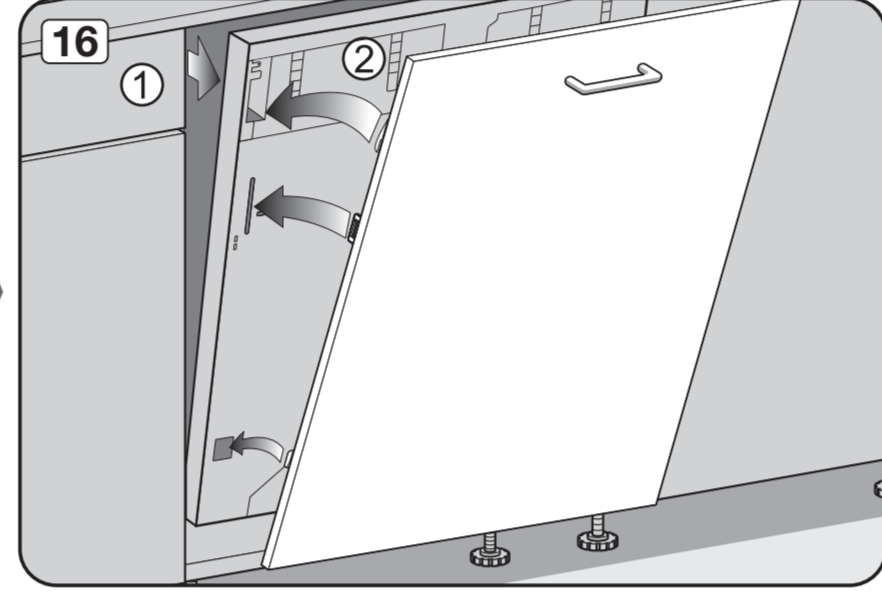
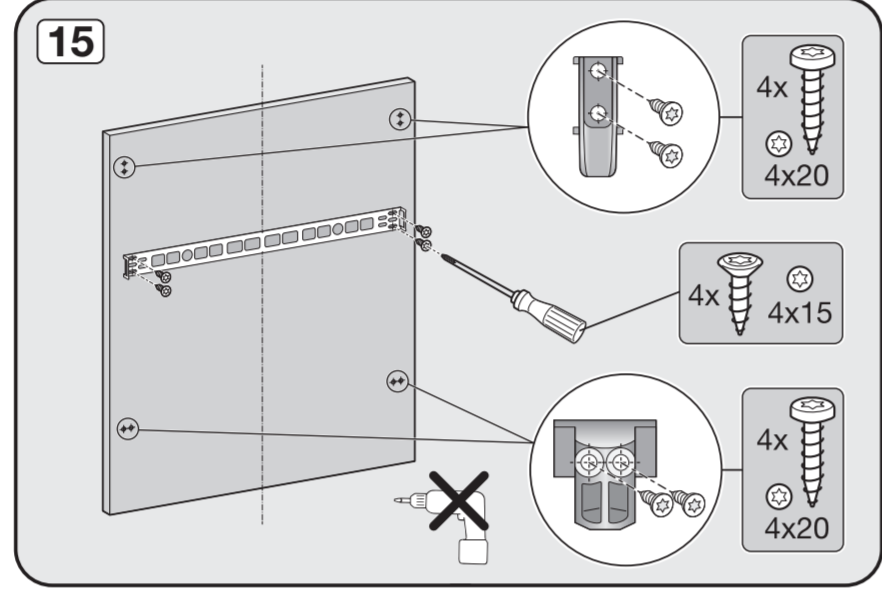
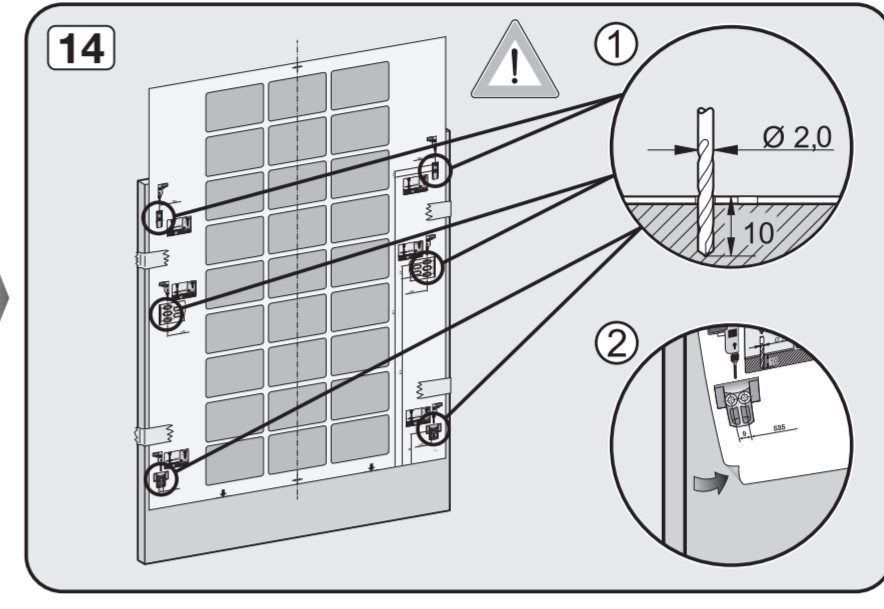
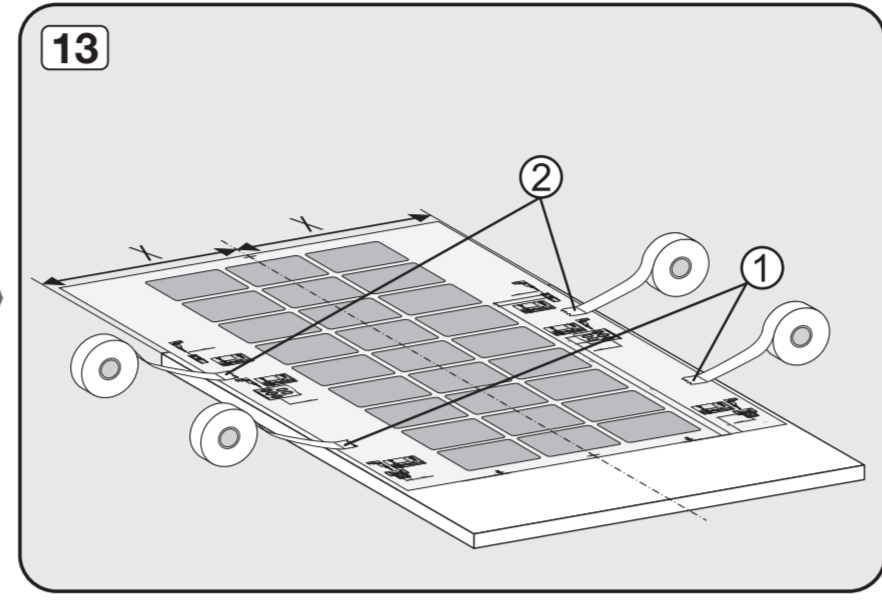
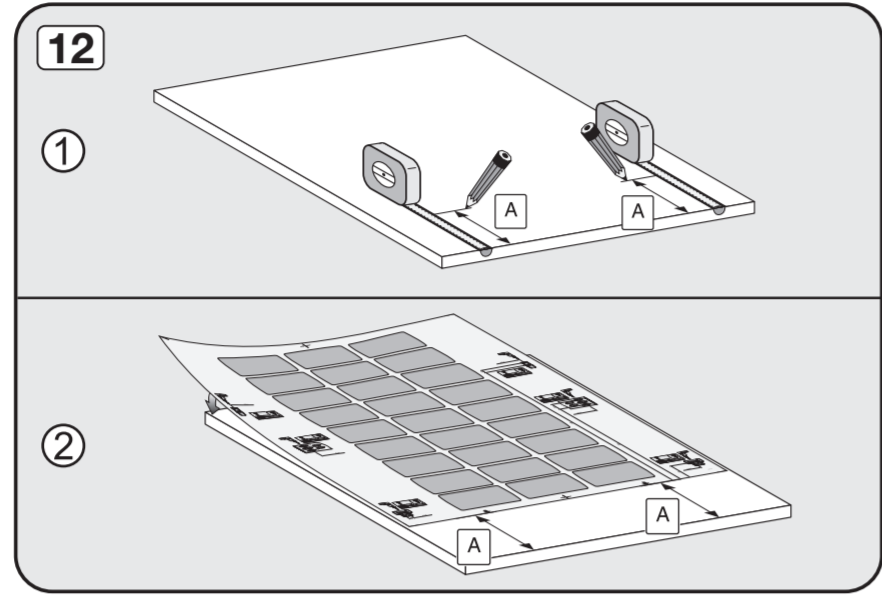
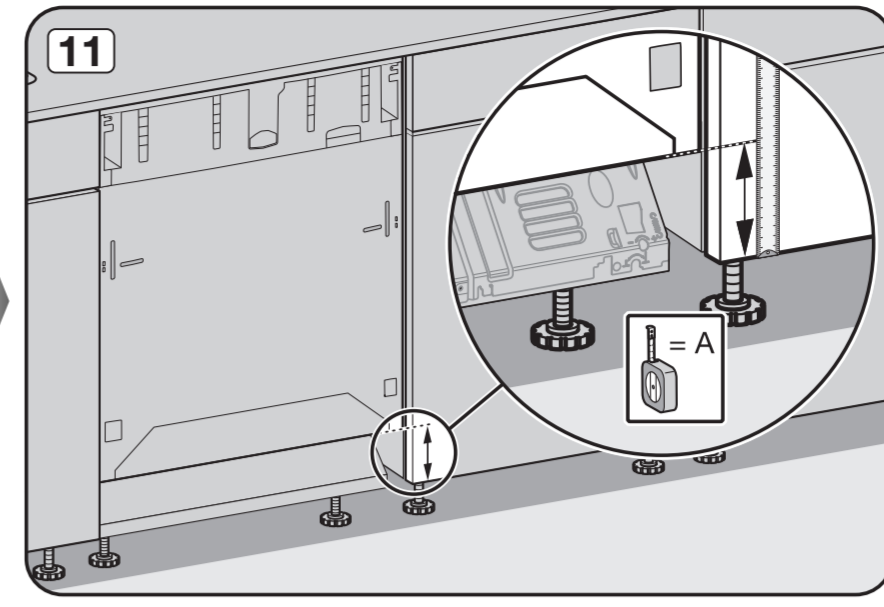
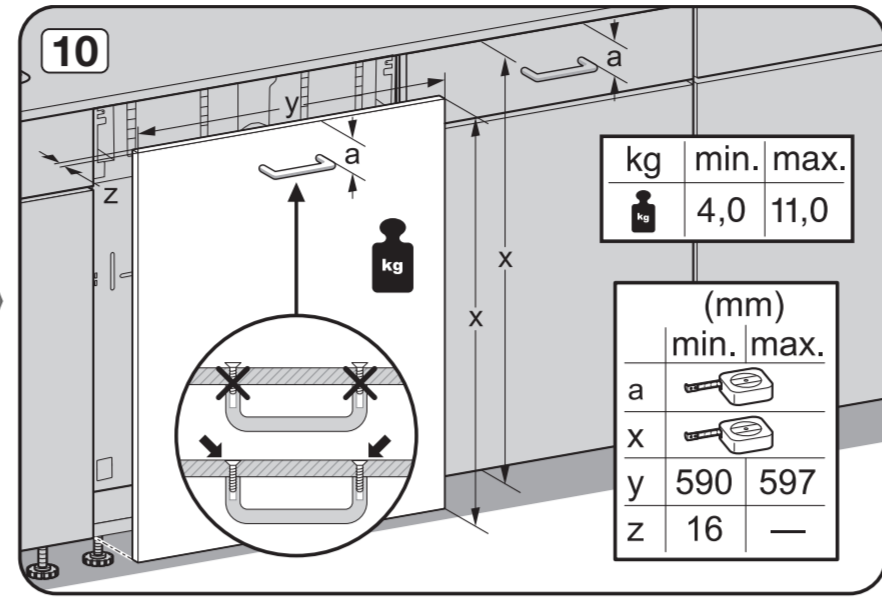
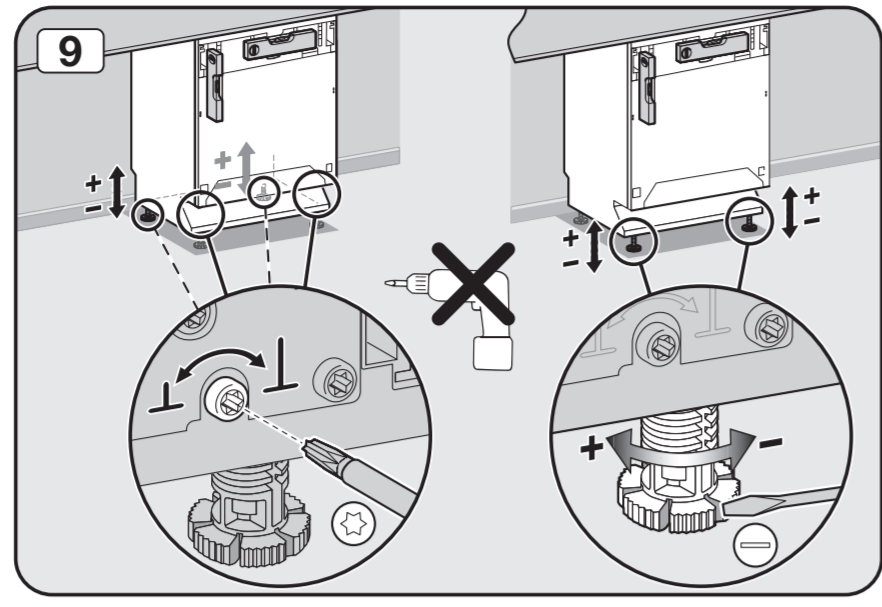

12

577

373