

Miele

Installation plan

Heat-pump dryer



PDR 908 HP

Always read the operating and installation instructions before setting up, installing, and commissioning the machine. This prevents both personal injury and damage to the machine.

en-CA

11 276 750/07

Please have the model and serial number of your machine available when contacting Technical Service.

U.S.A.

Miele, Inc.

National Headquarters

9 Independence Way
Princeton, NJ 08540
Phone: 800-991-9380
www.mieleusa.com/professional
prosales@mieleusa.com

Technical Service & Support

Phone: 800-991-9380
proservice@mieleusa.com

Canada

**Importer
Miele Limited**

Professional Division

161 Four Valley Drive
Vaughan, ON L4K 4V8
Phone: 1-888-325-3957
www.mieleprofessional.ca
professional@miele.ca

Miele Professional Technical Service

Phone: 1-888-325-3957
serviceprofessional@miele.ca



Miele & Cie. KG
Carl-Miele-Straße 29, 33332 Gütersloh, Germany

Legend:



Connection required



Connection optional or required,
depending on model

AL Vented
ASK Condensate drain hose
B Machine anchoring
EL Electrical connection
F Machine feet, adjustable
KG Payment system
KGA Payment system connection
KLA Cooling air vent

KLZ Cooling air intake
PA Potential equalization
SLA Peak-load connection
APCL SST Closed base
APCL OB Open base
APCL 001 Washer-dryer stacking kit
XKM Communication module
ZL Air intake

All rights reserved.

Machine dimensions

* The distances between the machine and the wall are recommendations to help make it easier to carry out service work. If installation space is limited, the machine can also be pushed up against the wall.

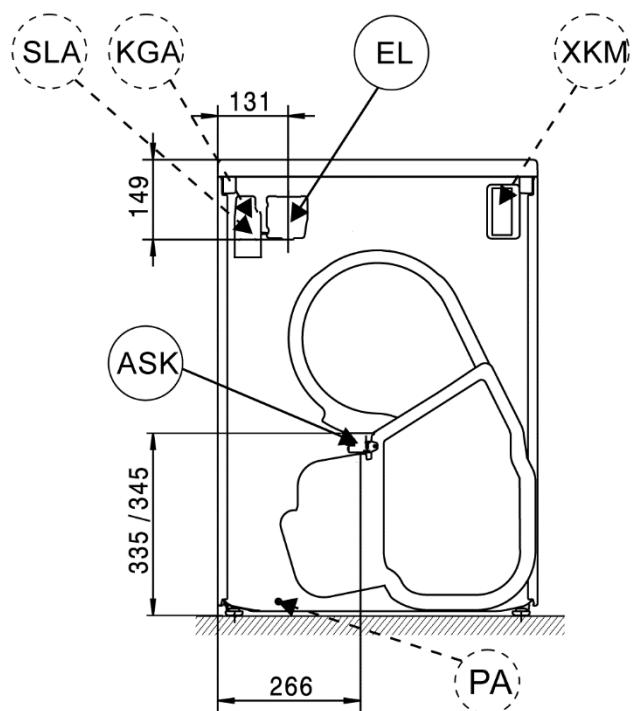
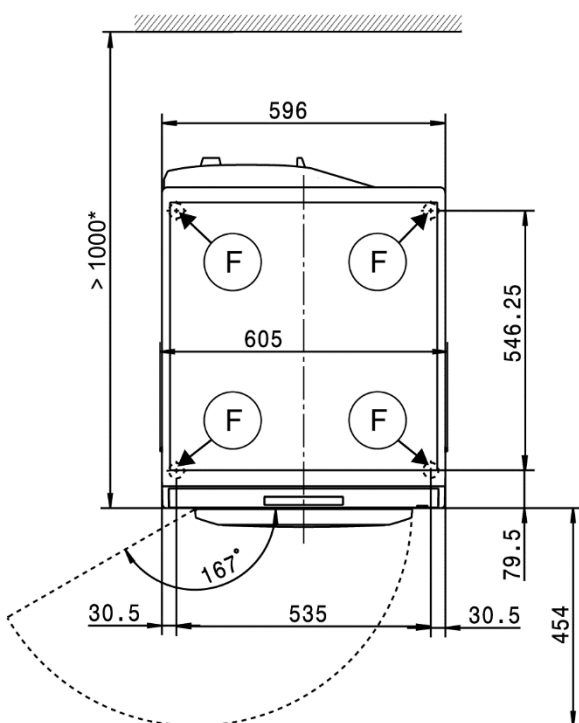
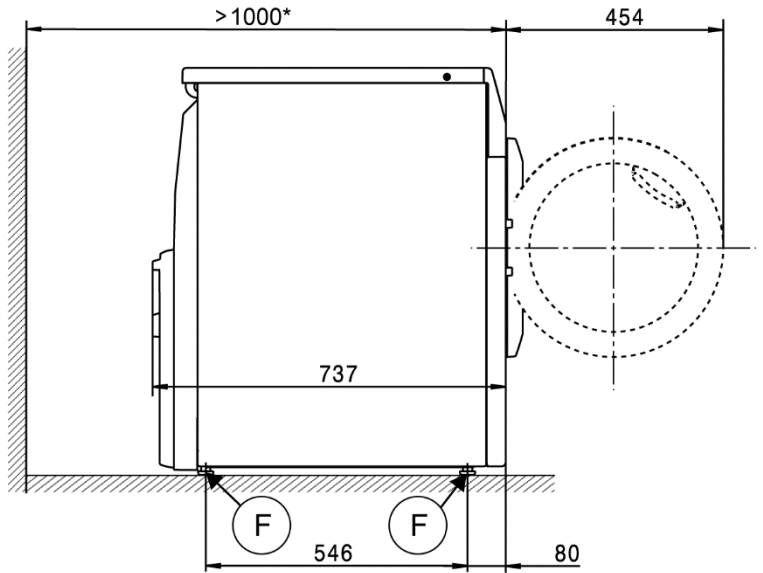
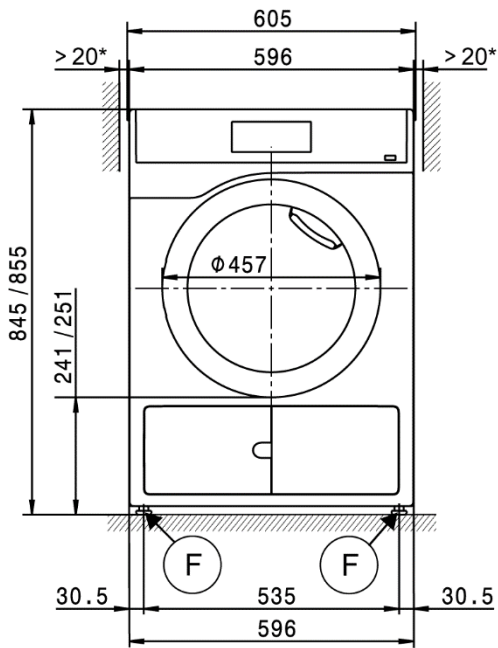

Installation

* The distances between the machine and the wall are recommendations to help make it easier to carry out service work. If installation space is limited, the machine can also be pushed up against the wall.

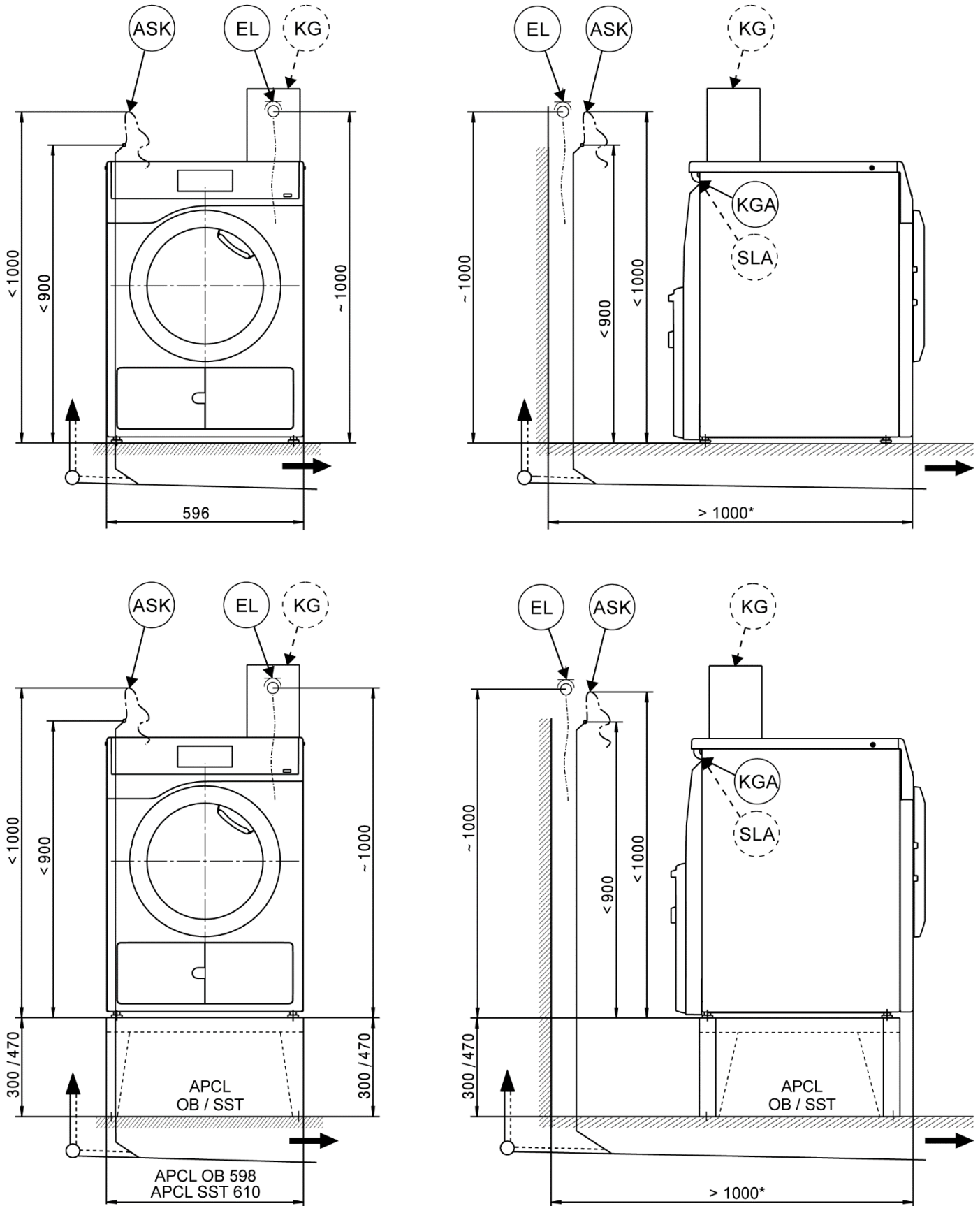

Washer-dryer stack

* The distances between the machine and the wall are recommendations to help make it easier to carry out service work. If installation space is limited, the machine can also be pushed up against the wall.

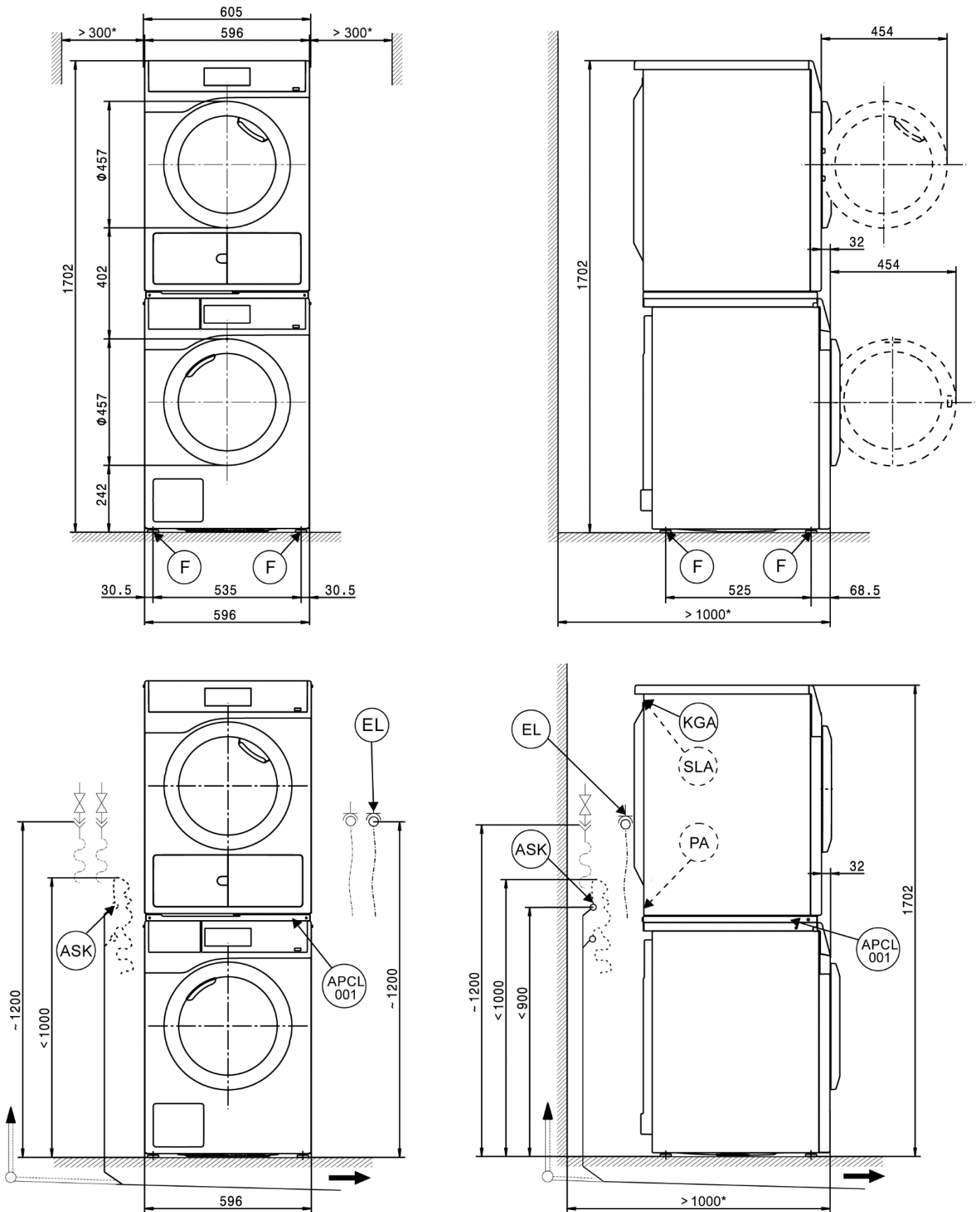

Installation

* The distances between the machine and the wall are recommendations to help make it easier to carry out service work. If installation space is limited, the machine can also be pushed up against the wall.

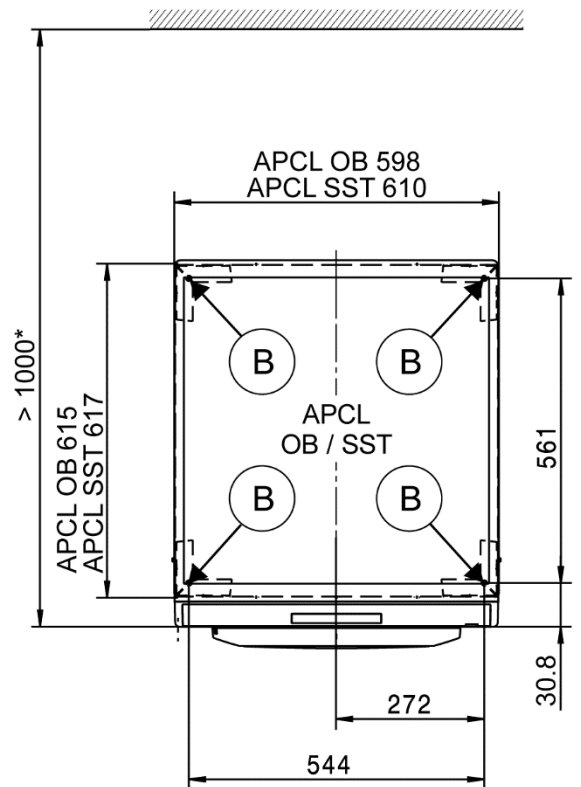
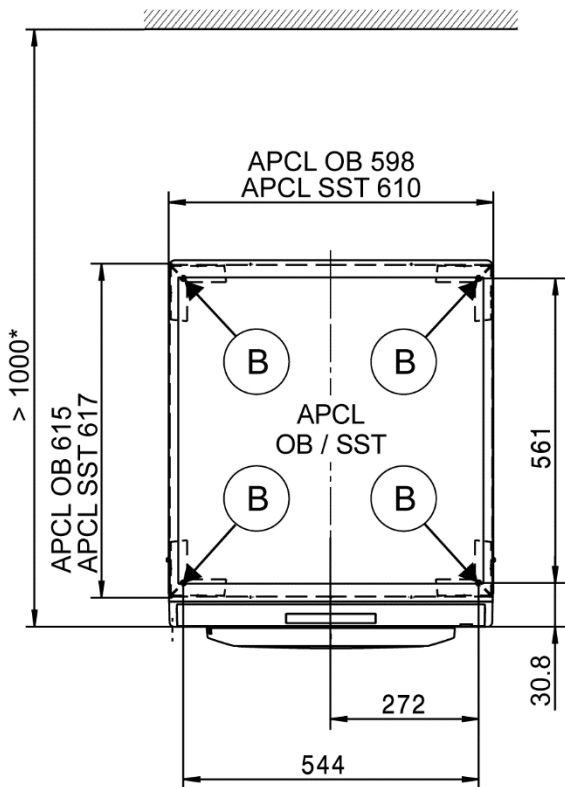
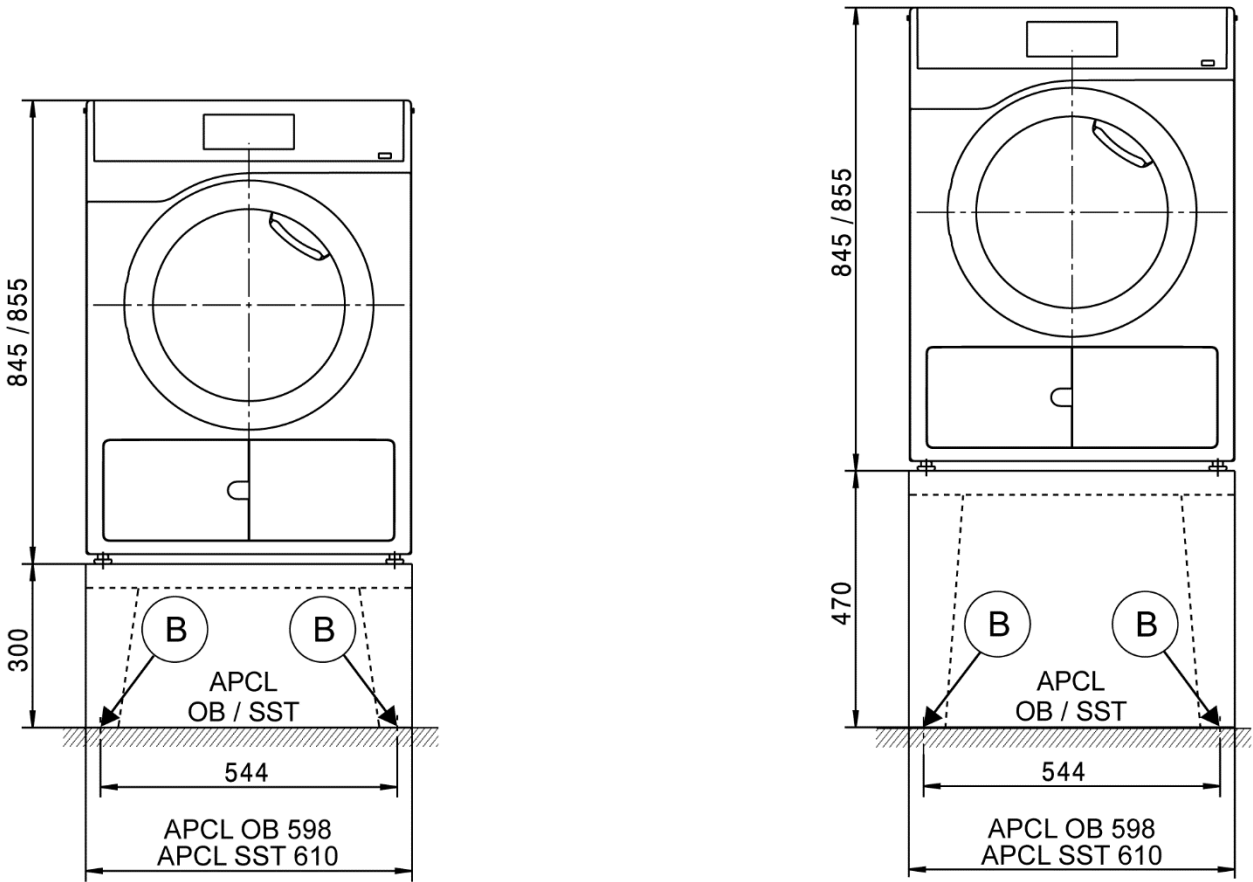

Technical data

		PDR 908 HP
Drying system		Heat pump
Drum volume	l	130 (4.59 ft ³)
Capacity	kg	8.0 (17.6 lb)
Door opening diameter	mm	370 (17 9/16 in)

Electrical connection (EL)

Standard voltage CDN & USA		2 AC 208–240 V
Frequency	Hz	60
Total rated load	kW	1.2
Fuse rating	A	2 x 30
Supply cable min. cross-section		3 x AWG10
Supply cable with plug type NEMA L6–30P		●
Length of supply cable	mm	2,100 (6.9 ft)

Non-standard voltage MAR 208–240 (Marine)		2 AC 208–240 V
Frequency	Hz	60
Total rated load	kW	1.2
Fuse rating	A	2 x 30
Supply cable min. cross-section		3 x AWG10
Supply cable with plug type NEMA L6–30P		●
Length of supply cable	mm	2,100 (6.9 ft)

Condensate drain hose (ASK)

Max. drainage temperature	°C	70 (158°F)
Max. transient flow rate	l/min	3.6 (0.95 gal/min)
On-site hose sleeve for drain hose	mm	10 x 30 (3/8 x 1 3/16 in)
Drain hose (internal diameter)	mm	10 (DN10)
Length of drain hose	mm	1,500 (4.9 ft)
Max. delivery head (from lower edge of machine)	mm	1,000 (3.3 ft)

Potential equalization (PA)

Machine connection (separate kit required)		○
--	--	---

XCI-Box / XCI-AD interface

		●
--	--	---

Peak load/energy management (SLA)

Machine connection (with XCI-Box)		○
-----------------------------------	--	---

Payment system connection (KGA)

Connection of payment systems (with XCI-Box / XCI-AD)		○
---	--	---

Communication module (XKM)

Communication module XKM 3200 WL PLT		○
--------------------------------------	--	---

Installation on machine feet (F)

No. of machine feet	No.	4
Machine foot, height-adjustable with thread	mm	± 5 (3/16 in)
Machine foot diameter	mm	31.7 (1 1/4 in)

Anchoring (B)

Anchoring of Miele bases

Miele base installation (fasteners included)		○
Required anchor points	No.	4
Wood screws according to DIN 571	mm	8 x 65 (5/16 x 2 9/16 in)
Rawl plugs (diameter x length)	mm	12 x 60 (1/2 x 2 3/8 in)

Base floor anchoring (to be provided on site)

Machine installation on on-site base (concrete or masonry)		○
Min. base installation footprint (W/D)	mm	600/650 (23 5/8 x 25 9/16 in)
Wood screws according to DIN 571	mm	6 x 50 (1/4 x 2 in)
Rawl plugs (diameter x length)	mm	8 x 40 (5/16 x 1 9/16 in)

● = standard, ○ = optional, + = only on request, - = not available

Technical data

PDR 908 HP

Machine data

Overall machine dimensions (H/W/D)	mm	850/605/777 (33 7/16 / 23 13/16 / 30 9/16 in)
Casing dimensions (H/W/D)	mm	850/596/737 (33 7/16 / 23 7/16 / 29 in)

Site-access dimensions (H/W)

Min. site-access opening (excl. packaging)	mm	900/605 (35 7/16 / 23 13/16 in)
--	----	---------------------------------

Installation dimensions

Side gap	mm	20 (13/16 in)
Recommended side gap – washer-dryer stack	mm	300 (11 13/16 in)
Recommended distance to opposite wall from front of machine	mm	1,000 (39 3/8 in)

Weights and floor loads

Machine weight (net weight)	kg	73 (161 lb)
Max. floor load in operation	N	925

Emissions

Sound pressure level (in accordance with EN ISO 11204/11203)	dB(A)	<70
Heat dissipation rate to installation site	W	950

● = standard, ○ = optional, + = only on request, - not available

Installation and planning notes

Installation requirements

The tumble dryer should only be connected to a power supply provided in accordance with all appropriate local and national legislation and regulations.

In addition, all regulations issued by the appropriate utilities as well as standards relating to occupational safety and all applicable valid regulations and technical standards must be observed.

General operating conditions

Ambient temperature in installation room: +2°C to +35°C (36°F to 95°F).

Air drawn in for use in the drying process will be warm when it is expelled back into the room. You must therefore ensure that the room is sufficiently ventilated, particularly if the dryer is located in a small room.

Make sure that the room temperature is not too high. If there are other heat-producing appliances in the room in which the dryer is located, make sure the room is well ventilated and switch the other appliances off, if possible.

Otherwise running times and energy consumption could be increased.

Electrical connection

This tumble dryer is supplied with a power cord and plug ready for connection.

The machine may only be connected to an electrical system that conforms to the national and local codes and regulations.

The tumble dryer should never be connected by an extension cord, e.g. power strips, to avoid the risk of fire.

The data plate indicates the nominal power consumption and the appropriate fuse rating. Compare the specifications on the data plate with those of the electrical power supply.

If the machine is hard-wired, a dual circuit breaker must be provided on site. When switched off, there must be an all-pole contact gap of at least 3 mm in the isolator switch (including circuit breakers, breakers, and relays according to IEC/EN 60947).

The plug connector or isolator switch should be easily accessible at all times. If the machine is disconnected from the electricity supply, the isolator must be lockable or the point of disconnection must be monitored at all times.

New connections, modifications to the system, or servicing of the ground conductor, including determining the correct fuse amperage, must be carried out by a qualified electrician, as they are familiar with the pertinent regulations and the specific requirements of the electric utility company.

References to cable cross-sections in the technical data refer only to the required power cord. Please consult relevant local and national regulations when calculating any other wire gauges.

Condensate drain hose

The condensed water is pumped away through the drain hose which is located at the back of the dryer.

The condensate is drained via a drain pump with a 1 m (3.3 ft) delivery head. For the water to drain freely, the hose must be installed free of kinks. The swivel elbow at the end of the hose can be turned in either direction or removed as needed.

In certain situations, this tumble dryer must be fitted with a non-return valve (optional accessory). Without a non-return valve, water could flow back into the tumble dryer or be drawn back in and leak out. This can cause damage.

Drainage options:

1. **Direct connection to a plastic drain pipe with a rubber sleeve.**
Use a non-return valve if the end of the hose could possibly become submerged in water.
2. **Connection to a sink with a plastic nipple.**
Always use a non-return valve.
3. **Connection to a floor drain (gully).**
Always use a non-return valve.
4. **Directed into a sink or basin.**
Secure the drain hose carefully (e.g. by tying it) to make sure it cannot slip. Otherwise water may escape and cause damage. Use a non-return valve if the end of the hose could possibly become submerged in water.

Potential equalization

If necessary, potential equalization with good galvanic contact must be guaranteed in compliance with all applicable local and national installation specifications.

Connection material for potential equalization must be provided on site or using a kit available from Miele Service.

Peak load/Energy management

The tumble dryer can be connected to a peak load or energy management system using an optional kit.

When the peak-load function is activated, the heating is deactivated. A message appears in the display to inform you of this.

Payment system

The tumble dryer can be fitted with a single-machine payment system as an optional accessory using an optional kit (XCI-Box / XCI-AD).

The programming required for connecting a payment system can be carried out during the initial commissioning process. After initial commissioning, changes may only be carried out by your Miele dealer or Miele Service.

Interface

The tumble dryer can be retrofitted with an XKM 3200 WL PLT communication module.

This module can be used as a WiFi or LAN interface.

The LAN interface provided via the module complies with SELV (Safety Extra Low Voltage) in accordance with EN 60950. Connected appliances must also comply with SELV. The LAN connection uses a RJ45 connector in accordance with EIA/TIA 568-B.

Installation and anchoring

The machine must be installed on a perfectly smooth, level and firm surface which is able to withstand the quoted loads.

The floor load created by the machine is concentrated and transferred to the installation footprint via the machine feet.

The tumble dryer should be levelled in both directions with the aid of the adjustable feet.

Base installation

The tumble dryer can be installed on a machine base (open or box base, available as an optional Miele accessory) or on a concrete base to be provided on site.

The quality of the concrete and its strength must be assessed according to the machine load. Ensure that any raised concrete base is adequately bonded to the floor below.

Washer-dryer stack

The tumble dryer can be installed as a washer-dryer stack together with a Miele Washing Machine. A stacking kit (optional accessory) is required for this.

Installation of the stacking kit must be performed by Miele Service or an authorized Miele service technician.