

Installation plan
Commercial washing machine
PW 6241 EL
Electric heating/Electric heating with
reduced heater rating







To avoid the risk of accidents or damage to the machine, it is **essential** to read these instructions before it is installed and used for the first time.

en-GB

Contents

Installation notes	3
Explanation of the safety instructions and warnings on the machine.....	3
Installation requirements	3
General operating conditions	3
Installation	3
Electrical connection	4
Water connection	5
Cold water connection	6
Hot water connection	6
Hard water connection	6
Drain valve.....	7
Dispenser pump connections	7
Optional accessories.....	8
BSK = Payment system kit.....	8
BSS peak-load negotiation kit	9
XKM RS232 communication module	9
Vapour and foam venting kit (APWM 063)	9
Installation	11
Installation	11
Installation	13
Dimensions.....	13
Standard floor anchoring.....	14
SOM floor anchoring	14
Technical data	15
Voltage versions and electrical data.....	15
Connection for equipotential bonding.....	15
Water connections	16
Cold water connection	16
Hot water connection (for variants with reduced heater rating)	16
Hard water connection	16
Waste water (drain valve).....	16
Securing the machine.....	16
Fittings.....	16
Emissions	16
Machine data.....	17
Transport data	17

Explanation of the safety instructions and warnings on the machine

	Read the operating instructions
	Read all the instructions, e.g. the installation instructions
	Warning, hot surfaces
	Warning, voltage up to 1000 volts
	Earthing
	Equipotential bonding

Installation requirements

The washing machine must be installed and commissioned by a Miele Service technician or by an authorised dealer.

- ▶ The washing machine must be installed in accordance with applicable regulations and standards. Local energy supplier and water authority regulations must also be observed.
- ▶ This washing machine must only be operated in a room that has sufficient ventilation and which is frost-free.

This machine should not be installed or operated in any area where there is a risk of explosion!

General operating conditions

This washing machine is intended only for use in a commercial environment and must only be operated indoors.

- Ambient temperature: 0-40 °C
- Relative humidity: non-condensing
- Maximum height above sea level of location site: 2000 m

Depending on the nature of the installation site, sound emissions and vibration may occur.

Tip: Have the installation site inspected and seek the advice of a professional in instances where increased noise may cause a nuisance.

Installation

Transport the washing machine to its installation site using a suitable pallet truck and remove the transport packaging.

Installation notes

The washing machine must be set up on a completely level, horizontal and firm surface with the minimum stated load bearing capacity (see “Technical data”).

Tip: A concrete floor is the most suitable installation surface. It is far less prone to vibration during the spin cycle than wooden floorboards or a carpeted surface.

The floor load created by the washing machine is the load exerted by the area of the machine in contact with and transferred to the installation footprint.

The washing machine requires a gap of at least 50 mm at each side to allow for movement during operation. Please ensure a minimum distance of 1800 mm is maintained between the machine and the rear wall.

The washing machine must not be installed on a carpeted floor.

The feet of the washing machine must be secured to the 4 fastening points on the floor using the fittings supplied.

The fittings supplied are for bolting the machine to a concrete floor. If other floor types are present at the installation site, the fastening material must be ordered by the customer.

The base frame of the washing machine contains four drilled holes through which it is possible to drill straight into the floor.

Electrical connection

The electrical connection must only be carried out by a qualified electrician who must ensure that all electrical work is carried out in accordance with applicable electrical regulations and standards (BS 7671 in the UK).

► This washing machine must be connected to an electrical mains supply that complies with local and national regulations. Please also observe your insurance and energy supplier's regulations as well as any health and safety at work regulations.

► The required voltage, connected load and fusing rating can be found on the data plate on the washing machine. Before connecting the machine to the power supply, please ensure that the mains supply voltage complies with the values given on the data plate.

Connection to a supply voltage other than the one quoted on the data plate can lead to functional faults and damage the washing machine!

If more than one voltage is quoted on the data plate, the washing machine can be converted for connection to the voltages stated.

► Conversion to a different voltage must only be carried out by a Miele Service engineer or by an authorised Service Dealer. The wiring instructions given on the wiring diagram must be followed.

Tip: We recommend connection to the power supply via a suitably rated plug and socket which must be easily accessible for servicing and maintenance work after the machine has been installed. An electrical safety test must be carried out after installation and after any service work.

The machine can either be hard-wired or connected using a plug-and-socket connection in accordance with IEC 60309-1. For a hard-wired connection an all-pole isolation device must be installed on site.

For hard-wired machines connection should be made via a suitable mains switch with all-pole isolation which, when in the off position, ensures a 3 mm gap between all open contacts. These include circuit breakers, fuses and relays (IEC/EN 60947).

If the mains supply cannot be permanently disconnected, the isolator switch (including plug and socket) must be safeguarded against being switched on either unintentionally or without authorisation.

► If it is necessary to install a residual current device (RCD) in accordance with local regulations, a residual current device type B (sensitive to universal current) must be used.

An existing type A residual current device (RCD) must be exchanged for a type B RCD.

An equipotential bond with good contact connection must always be provided in accordance with all national and local regulations. Accessories for equipotential bonding are not supplied and need to be ordered separately.

Water connection

According to national regulations for drinking water quality, with effect from 21 March 2021, a non-return valve to prevent backsiphoning must be fitted between the stopcock and the water inlet hose during commissioning on all appliances in Germany. The non-return valve prevents water from the water inlet hose from flowing back into the on-site drinking water supply.

Non-return valves are supplied.

The flow pressure must amount to a minimum of 100 kPa and must not exceed 1000 kPa. If the flow pressure is higher than 1000 kPa, a pressure reducing valve must be used.

The machine must be connected to the water supply using the inlet hoses provided.

⚠ The connection points are subject to water supply pressure. Turn on the stopcock slowly and check for leaks. Correct the position of the seal and screw thread if appropriate.

Installation notes

The use of rubber or plastic tubing as pressure connection piping between the installation location interior and the machine is only permitted if:

- in conjunction with connection fittings, it can withstand a minimum permanent pressure of 1500 kPa (15 bar),
- it is satisfactorily inspected during commissioning and
- after each use of the machine the water supply is reliably cut off before the rubber and plastic piping and put out of service or cut off from the location interior.

Cold water connection

For the cold water connection one stopcock each with a 3/4" external thread is required. A connector (Y-piece) can be used if required to connect 2 water inlet hoses with a 3/4" screw thread to a single stopcock with a 1" male thread.

The water inlet hose for cold water (blue stripes) is not intended to be used with a hot water connection.

Hot water connection

To minimise energy consumption during operation with hot water, the washing machine should be connected to a suitable hot water ring circuit if present.

So-called "transmission pipes" (single pipes to hot water generators) can result in cooling down of the water remaining in the pipes if not in constant use. More energy would then be consumed to heat the suds up again.

Use the inlet hose supplied (red stripes) for the hot water connection.

The temperature of the water intake must not exceed 60 °C on machines with electric heating (EL).

The temperature of the water intake must not exceed 90 °C on machines with reduced heater rating (RH).

The machine must be connected to the water supply using the inlet hoses provided.

If there is no hot water supply at the installation location for the washing machine, the inlet hose for hot water must also be connected to the cold water supply. A Y-piece is required in this case. The cold water consumption increases accordingly to account for the missing hot water intake.

For functional and technical reasons it is not possible to operate the machine exclusively with a hot water connection.

Even if a hot water connection is present, the washing machine must be connected to a cold water intake.

Hard water connection

Connection for hard water. For the hard water connection, the same requirements apply as for the cold water connection.

If there is no hard water connection on site, the hose must be connected to the cold water connection.

Drain valve

In the case of washing machines with a drain valve, a motorised valve is used to drain the machine. An HT DN 70 angle connector can be used for draining the machine directly into the waste water system (without a siphon) or into an on-site floor drain (with odour trap).

Thanks to an improved closing mechanism and a larger cross-section, even the coarsest of soiling does not leave any deposits or debris behind which could result in blockages. The drain valve can also be operated manually to allow the suds container to be emptied in the event of a power outage.

A vented drainage system is vital for unimpeded drainage. If several machines are connected to a single drain pipe, this should be sufficiently large to allow all machines to drain simultaneously. The appropriate Miele installation kit (mat. no.: 05 238 090) is available to order from the Miele Customer Service Department or your Miele dealer for venting an HT DN 70 pipe. If the slope for drainage is extremely steep, the piping must be vented to prevent formation of a vacuum in the machine's drainage system.

Slow or obstructed drainage or a backup of water in the drum as a result of undersized pipework can result in faults occurring during programmes, which will result in fault messages appearing in the display.

⚠ Outflowing suds can be as hot as 95 °C. Danger of burning!
Avoid direct contact.

Dispenser pump connections

Up to 12 dispenser pumps can be connected to the washing machine.

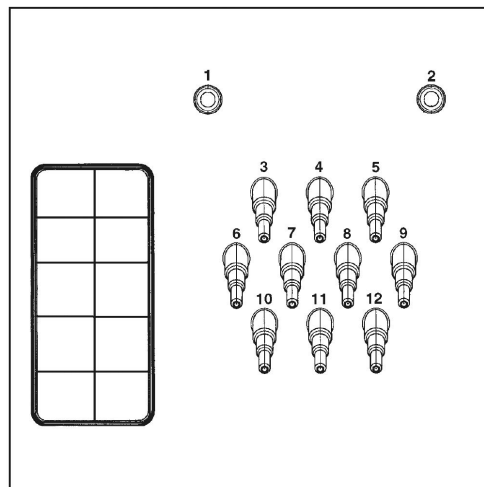

Dispenser pump connections on the back of the machine

Installation notes

Connections **1** and **2** are provided for viscous agents can also be used for high pressure dispensing systems with water injection. The dispensing systems must be fitted with a separate drinking water safety mechanism in accordance with EN 61770 and EN 1717. The maximum flow rate is 1500 ml/min with a maximum flow pressure of 300 kPa.

These connectors are sealed and need to be drilled open using a 8 mm drill bit before connecting.

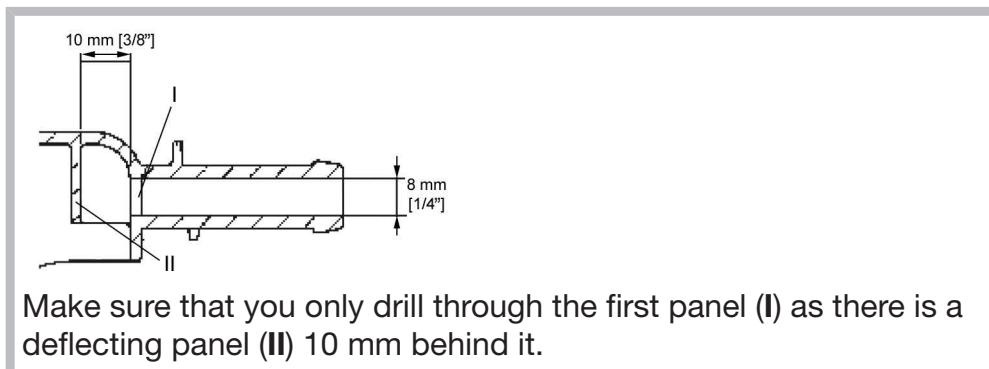

Connections **3** to **12** are provided for liquid detergent. High pressure dispensing systems with water injection must not be connected to these connections. The connectors are sealed and must be cut to the diameter of the hose with a small saw before they are connected.

If opened connectors are no longer required, they must be resealed using a suitable sealant (e.g. silicone).

Connection terminals for five time-controlled dispenser pumps, which can be operated without a multifunction module, are located behind the cover adjacent to the electrical connection.

Calibration of the dispenser pumps and regulation of dispensing quantities is carried out partly automatically for washing machines fitted with an optional multifunction module. Information regarding settings is given in the operating instructions.

A flowmeter or flow sensors can also be connected for monitoring the dispensing quantity precisely.

Connections for level monitoring are available for every agent dispensed.

Optional accessories

Only use genuine Miele spare parts and accessories with this machine.

Using spare parts or accessories from other manufacturers will invalidate the guarantee, and Miele cannot accept liability.

BSK = Payment system kit

The washing machine can be equipped with a payment system (e.g. for self-service operations) using the optional BSK payment system kit. This must be connected and programmed by a Miele Service

technician. Payment systems with mechanical or electronic coin validator are available from Miele as optional accessories for individual target groups.

The programming required for connecting a payment system must be carried out by Miele Service or an authorised Miele dealer only. A separate electrical connection is not required for a payment system.

BSS peak-load negotiation kit

The washing machine can be connected to a peak-load shut-off or an energy management system using a BSS peak-load negotiation kit which is available as an optional accessory.

The peak-load cut-out monitors the energy consumption of a system and deactivates individual pieces of equipment temporarily in order to ensure that certain total load limits are not exceeded. Monitoring is externally controlled.

The kit provides three signal contacts and a neutral conductor via a terminal block. The terminal block is marked with “a”, “b”, “c”, and “d”.

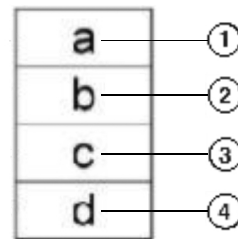

- ① Output signal, start of machine operation
- ② Output signal, machine heating request
- ③ Peak-load input signal, machine heating deactivated
- ④ Neutral conductor

When the peak-load function is activated the current programme is stopped and a message appears in the display on the washing machine. At the end of the peak-load function the programme resumes automatically.

XKM RS232 communication module

The serial interface RS-232 can be retrofitted to the washing machine via an XKM RS 232 (optional accessory available from Miele). This communication module must only be used with Miele Professional machines that are fitted with an appropriate slot for the module.

The data interface provided via communication module XKM RS232 complies with SELV (Safety Extra Low Voltage) in accordance with EN 60950. Appliances connected to this interface must also be SELV compliant.

Communication module XKM RS 232 is supplied with a connection cable and a D-sub-connector.

Installation notes

Vapour and foam venting kit (APWM 063) If excessive suds form, foam may escape from the vapour vent. To remove the foam, an optional vapour and foam venting kit (BWS) can be used.

Installation

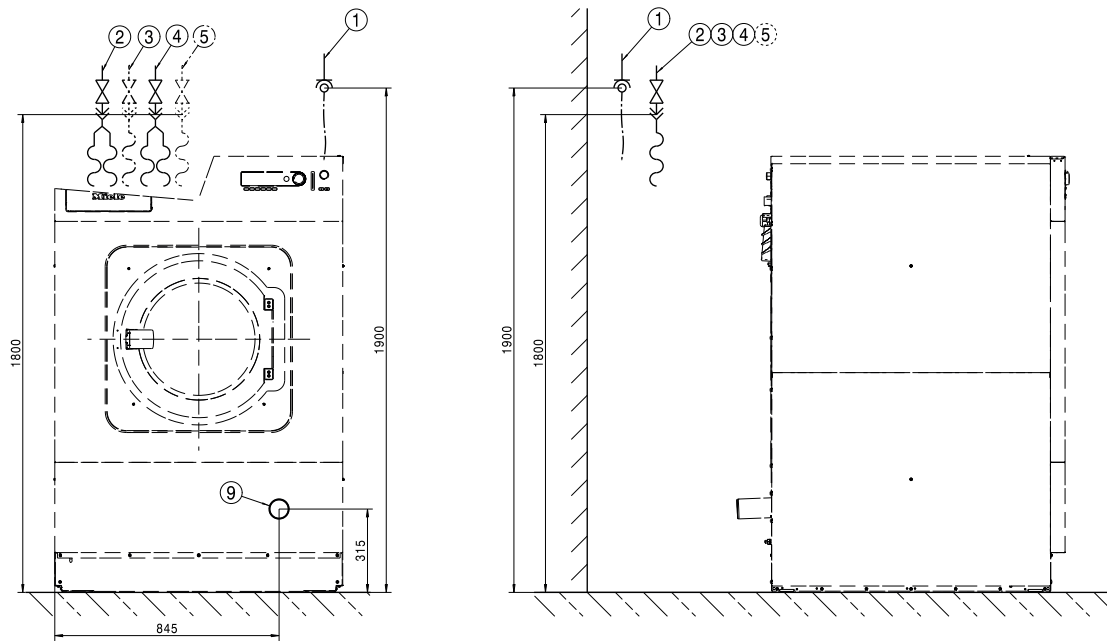

- ① Electrical connection
- ② Cold water connection
- ③ Hot water connection
- ④ Cold water connection (alternatively, hard water connection)
- ⑤ Cold water connection for liquid dispensing (optional)
- ⑥ Dispenser pump connections
- ⑦ Overflow
- ⑧ Communication connection
- ⑨ Drain pipe

Installation

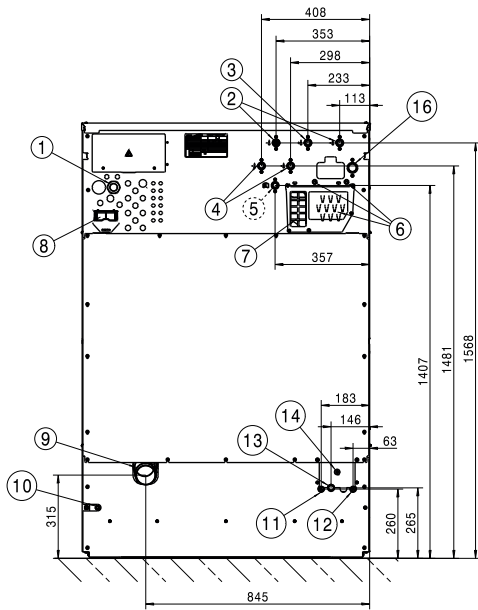

- ① Electrical connection
- ② Cold water connection
- ③ Hot water connection
- ④ Cold water connection (alternatively, hard water connection)
- ⑤ Cold water connection for liquid dispensing (optional)
- ⑥ Dispenser pump connections
- ⑦ Overflow
- ⑧ Communication connection
- ⑨ Drain pipe
- ⑩ Connection for equipotential bonding

Dimensions

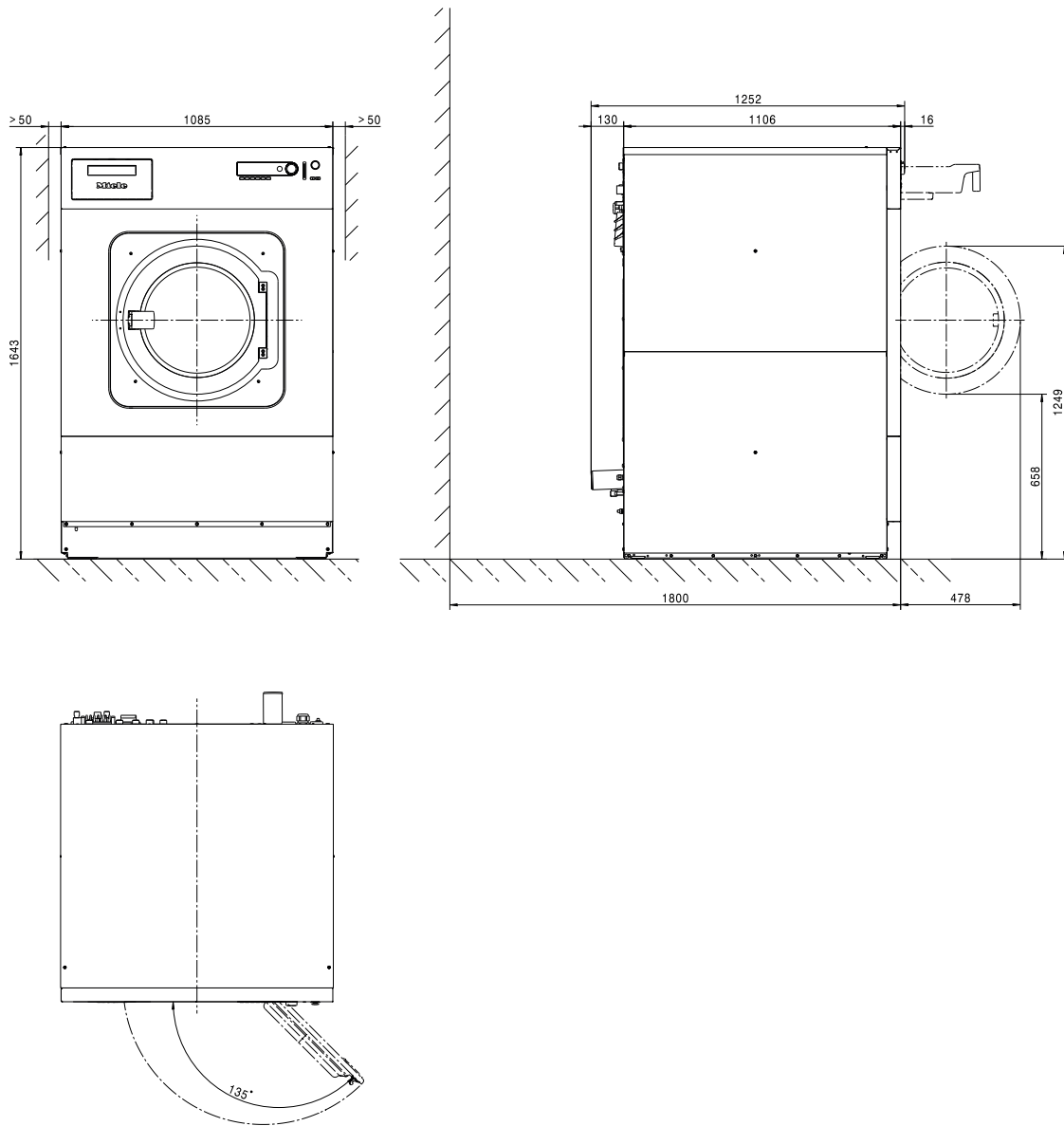

Installation

Standard floor anchoring

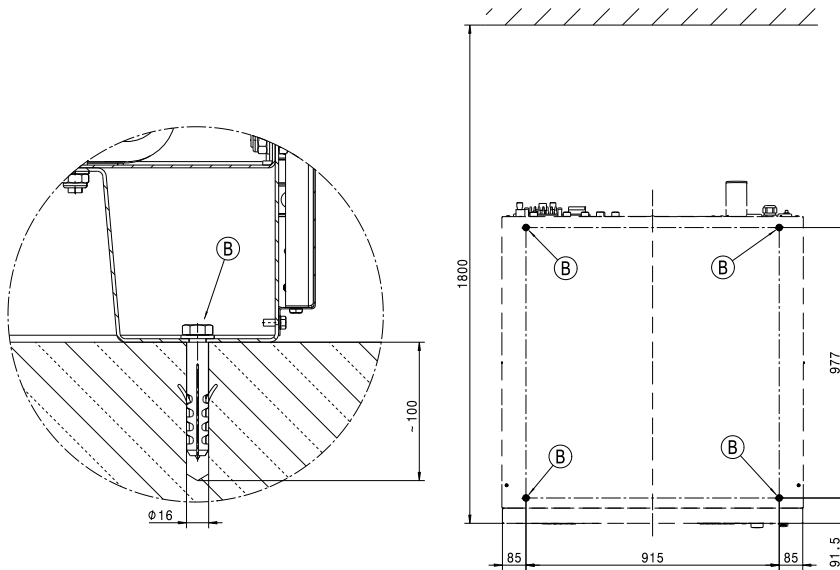

Dimensions in mm

Ⓑ screw/anchor point

SOM floor anchoring

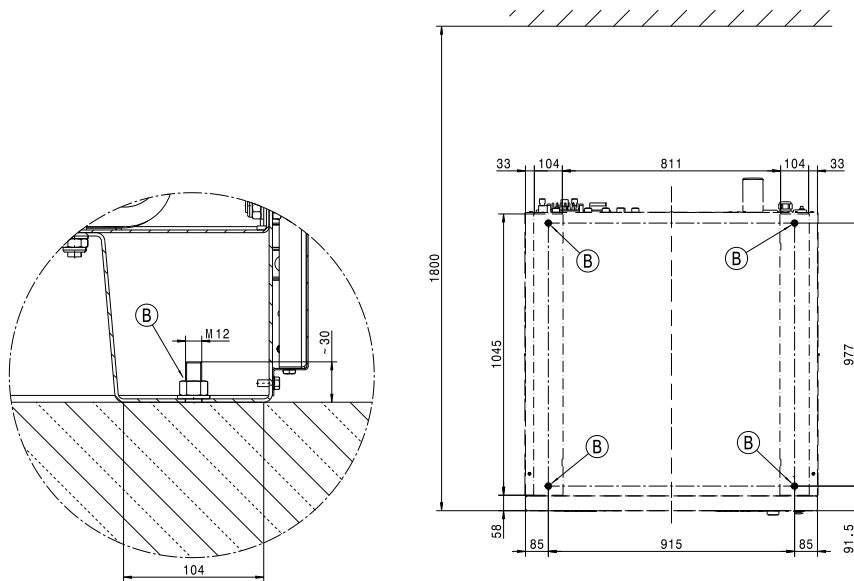

Dimensions in mm

Ⓑ screw/anchor point

Voltage versions and electrical data

	<i>Standard:</i>	<i>Convertible to:</i>
Supply voltage	3 AC 220 - 240 V	3 AC 208 V
Frequency	50 Hz	60 Hz
Power rating	25 kW	20 kW
Fuse rating (on site)	3 x 80 A	3 x 70 A
Connection cable, min. cross-section	4 x 25 mm ²	4 x 25 mm ²
Cable gland	M40 x 1,5 mm	M40 x 1,5 mm
	<i>Standard:</i>	<i>Convertible to:</i>
Supply voltage	3 AC 220-240V	3 AC 220-240V
Frequency	50 Hz	60 Hz
Power rating	25 kW	25 kW
Fuse rating (on site)	3 x 80 A	3 x 80 A
Connection cable, min. cross-section	4 x 25 mm ²	4 x 25 mm ²
Cable gland	M40 x 1,5 mm	M40 x 1,5 mm
	<i>Standard:</i>	<i>Convertible to:</i>
Supply voltage	3N AC 380–415 V	3N AC 380-415 V
Frequency	50 Hz	60 Hz
Power rating	25 kW	25 kW
Fuse rating (on site)	3 x 50 A	3 x 50 A
Connection cable, min. cross-section	5 x 16 mm ²	5 x 16 mm ²
Cable gland	M16 x 1,5 mm	M16 x 1,5 mm
	<i>Standard:</i>	<i>Convertible to:</i>
Supply voltage	3N AC 380-415V	3N AC 380-415V
Frequency	50 Hz	60 Hz
Power rating	10,5 kW	10,5 kW
Fuse rating (on site)	3 x 16 A	3 x 16 A
Connection cable, min. cross-section	5 x 1,5 mm ²	5 x 1,5 mm ²
Cable gland	M16 x 1,5 mm	M16 x 1,5 mm
Supply voltage		3 AC 440V
Frequency		60 Hz
Power rating		25 kW
Fuse rating (on site)		3 x 50 A
Connection cable, min. cross-section		5 x 16mm ²
Cable gland		M16 x 1,5 mm

Miele recommends connecting the machine via a wall socket with an all-pole means of deactivation and interlock in accordance with IEC 60309 and IEC 60947 so that electrical safety checks can be carried out easily.

For hard-wired machines, an isolator in accordance with IEC 60947 must be installed.

The wall socket or isolator must remain accessible at all times once the machine has been installed.

To increase safety, Miele recommends installation of a residual current device (RCD). Only use residual current devices that are sensitive to universal current (type B).

Connection for equipotential bonding

Connection with male thread (machine)	10 mm x 30 mm (3/8" x 1 3/16")
Size of washers and nuts	M 10

An  equipotential bond with good contact connection must always be provided in accordance with all national and local regulations.

Technical data

Water connections

Cold water connection

Required flow pressure	100–1000 kPa (1–10 bar)
Maximum flow rate (if no hot water and hard water supply)	74 (79,5*) l/min
Maximum flow rate	26 (31,5*) l/min
Threaded union required (to be provided by customer in accordance with DIN 44991, flat sealing)	3/4"
Length of water inlet hose supplied	1550 mm
*With liquid dispensing	

Hot water connection (for variants with reduced heater rating)

Hot water connection (for variants with reduced heater rating)	90°
Required flow pressure	100–1000 kPa (1–10 bar)
Maximum flow rate	74 (79,5*) l/min
Threaded union required (in accordance with DIN 44991, flat sealing)	1"
Length of water inlet hose supplied	1550 mm

Hard water connection

Required flow pressure	100–1000 kPa (1–10 bar)
Maximum flow rate	32 l/min
Threaded union required (in accordance with DIN 44991, flat sealing)	3/4"
Length of water inlet hose supplied	1550 mm

Waste water (drain valve)

Maximum waste water temperature	95 °C
Machine-side drain connection (external diameter)	HT DN 70
On-site drain (internal diameter)	75 x 1,9 x 110 mm (Muffe DN 70)
Maximum flow rate	200 l/min

A vented combined pipe is required to drain the waste water. If several machines are connected to a single drain pipe, this should be sufficiently large to allow all machines to drain simultaneously.

Securing the machine

Fittings

4 x wood screws DIN 571 (Ø x length)	12 mm x 90 mm
4 x plugs (Ø x length)	16 mm x 80 mm
Fixing the machine in place is absolutely essential.	
Fastenings for floating screed must be supplied by the customer on site.	

Emissions

Average heat dissipation rate to installation room	4,7 MJ/h
Emission sound pressure level in the workplace	78 dB(A) re 20 µPa
Sound power level, washing	60,3 dB (A) re 1 pW
Sound power level, spinning	82,2 dB (A) re 1 pW

Machine data

Machine width (without add-on components)	1085 mm
Machine height (without add-on components)	1643 mm
Machine depth (without add-on components)	1106 mm
Machine width, total	1089 mm
Machine height, total	1646 mm
Machine height, total	1252 mm
Minimum width of loading aperture (internal diameter)	1185 mm
Recommended wall spacing up to the front edge of the machine	1800 mm
Net weight	640 kg
Max. floor load in operation	8417 N
Maximum static load	7063 N
Maximum dynamic load	1353 N
Maximum rotation frequency of drum	18,3 Hz

Transport data

Packaging width	1260 mm
Packaging height	1710 mm
Packaging depth	1470 mm
Gross weight	691 kg

United Kingdom

Miele Co. Ltd., Fairacres, Marcham Road
Abingdon, Oxon, OX14 1TW
Professional Sales, Tel: 0845 365 6608
E-mail: professional@miele.co.uk
Internet: www.miele.co.uk/professional

Australia

Miele Australia Pty. Ltd.
ACN 005 635 398, ABN 96 005 635 398
Level 4, 141 Camberwell Road, Hawthorn East, VIC 3123
Tel: 1300 731 411
Internet: www.miele.com.au/professional
E-mail: sales@miele-professional.com.au

China Mainland

Miele Electrical Appliances Co., Ltd.
1-3 Floor, No. 82 Shi Men Yi Road
Jing' an District, 200040 Shanghai, PRC
Tel: +86 21 6157 3500, Fax: +86 21 6157 3511
E-mail: info@miele.cn, Internet: www.miele.cn

Hong Kong, China

Miele (Hong Kong) Ltd.
41/F - 4101, Manhattan Place
23 Wang Tai Road, Kowloon Bay, Hong Kong
Tel: (852) 2610 1025, Fax: (852) 3579 1404
Email: customerservices@miele.com.hk
Website: www.miele.hk

India

Miele India Pvt. Ltd.
1st Floor, Copia Corporate Suites,
Commercial Plot 9, Mathura Road, Jasola,
New Delhi - 110025
E-mail: customercare@miele.in, Website: www.miele.in

Ireland

Miele Ireland Ltd.
2024 Bianconi Ave., Citywest Business Campus, Dublin 24
Tel: (01) 461 07 10, Fax: (01) 461 07 97
E-Mail: info@miele.ie, Internet: www.miele.ie

Malaysia

Miele Sdn Bhd
Suite 12-2, Level 12
Menara Sapura Kencana Petroleum
Solaris Dutamas No. 1, Jalan Dutamas 1
50480 Kuala Lumpur, Malaysia
Phone: +603-6209-0288
Fax: +603-6205-3768

New Zealand

Miele New Zealand Limited
IRD 98 463 631
8 College Hill
Freemans Bay, Auckland 1011, NZ
Tel: 0800 464 353
Internet: www.miele.com.au/professional
E-mail: sales@miele-professional.com.au

Singapore

Miele Pte. Ltd.
29 Media Circle, #11-04 ALICE@Mediapolis
Singapore 138565
Tel: +65 6735 1191, Fax: +65 6735 1161
E-Mail: info@miele.com.sg
Internet: www.miele.sg

South Africa

Miele (Pty) Ltd
63 Peter Place, Bryanston 2194
P.O. Box 69434, Bryanston 2021
Tel: (011) 875 9000, Fax: (011) 875 9035
E-mail: info@miele.co.za
Internet: www.miele.co.za

United Arab Emirates

Miele Appliances Ltd.
Showroom 1, Eiffel 1 Building
Sheikh Zayed Road, Umm Al Sheif
P.O. Box 114782 - Dubai
Tel. +971 4 3044 999, Fax. +971 4 3418 852
800-MIELE (64353)
E-Mail: info@miele.ae, Website: www.miele.ae



Manufacturer: Miele & Cie. KG
Carl-Miele-Straße 29, 33332 Gütersloh, Germany