

## Operating and installation instructions ProLine Gas wok



It is **essential** to read the operating and installation instructions before setup, installation, and commissioning. This prevents both personal injury and damage to the appliance.

---

This appliance can be used in countries other than those specified on the appliance and in these operating and installation instructions. It is, however, set up for connection to the gas and electricity supplies in the countries specified. For trouble-free operation of the appliance, it is best to use it in the countries specified for use.

For use in other countries, please contact Miele in your country.

### **Safety precautions to take if you smell gas**

- Turn off the gas emergency control valve immediately.  
This is usually located near the gas meter.
- Eliminate all sources of ignition in a safe manner.  
Do not smoke, light cigarette lighters or matches.
- Do not operate electrical lights or switches, i.e. do not switch them „On“ or „Off“.
- Open all doors and windows to ventilate the area.
- If the smell of gas persists, evacuate the building.

# Contents

---

<b>Warning and Safety instructions</b> .....	<b>6</b>
<b>Caring for the environment</b> .....	<b>16</b>
<b>Guide to the appliance</b> .....	<b>17</b>
Wok .....	17
Rotary controls .....	18
Burner.....	19
Accessories supplied .....	20
<b>Before using for the first time</b> .....	<b>21</b>
Cleaning the ProLine element for the first time .....	21
Switching on the ProLine element for the first time .....	21
<b>Pans</b> .....	<b>22</b>
<b>Tips on saving energy</b> .....	<b>24</b>
<b>Operation</b> .....	<b>25</b>
Switching on.....	25
Adjusting the flame .....	26
Switching off .....	26
<b>Safety features</b> .....	<b>27</b>
Thermo-electric flame failure monitor.....	27
<b>Cleaning and care</b> .....	<b>28</b>
Cleaning the stainless steel trough.....	29
Cleaning the rotary controls.....	30
Cleaning the trivets .....	30
Cleaning the wok ring/combination trivet .....	30
Cleaning the burners.....	31
Assembling the burners.....	32
<b>Problem solving guide</b> .....	<b>34</b>
<b>Optional accessories</b> .....	<b>36</b>
<b>After sales service</b> .....	<b>37</b>
Contact in the event of a fault .....	37
Data plate .....	37
Guarantee .....	37
<b>Installation</b> .....	<b>38</b>
Safety instructions for installation .....	38
Safety distances .....	39
Installation notes .....	42
Building-in dimensions .....	43
Worktop cut-out for several ProLine elements .....	44

# Contents

---

Installation.....	46
Fitting the ProLine element.....	48
Gas connection.....	50
Burner ratings .....	53
Electrical connection .....	54
<b>Converting to another gas type .....</b>	<b>55</b>
Jet table.....	55
Changing the jets.....	55
Functional check.....	58

## Warning and Safety instructions

---

This wok complies with all current local safety requirements. Inappropriate use can, however, lead to personal injury and damage to property.

To avoid the risk of accidents and damage to the wok, please read these instructions carefully before installation and before using it for the first time. They contain important notes on installation, safety, use and maintenance.

Miele cannot be held liable for damage caused by non-compliance with these instructions.

Keep these instructions in a safe place and ensure that new users are familiar with the content. Pass them on to any future owner.

### Correct application

- ▶ This wok is designed for domestic use and for use in similar environments.
- ▶ This wok is not intended for outdoor use.
- ▶ This wok is intended for domestic use only to cook food and keep it warm. Any other use is not supported by the manufacturer and could be dangerous.
- ▶ People with reduced physical, sensory or mental capabilities, or lack of experience and knowledge who are not able to use the wok safely on their own must be supervised whilst using it. They may only use it unsupervised if they have been shown how to use it safely and recognise and understand the consequences of incorrect operation.

# Warning and Safety instructions

---

## Safety with children

- ▶ Children under 8 years of age must be kept away from the wok unless they are constantly supervised.
- ▶ Children aged 8 and older may only use the wok without supervision if they have been shown how to use it in a safe manner. Children must be able to understand and recognise the possible dangers caused by incorrect operation.
- ▶ Children must not be allowed to clean the wok unsupervised.
- ▶ Please supervise children in the vicinity of the wok and do not let them play with it.
- ▶ The wok gets hot when in use and remains hot for a while after being switched off. Keep children well away from the appliance until it has cooled down and there is no danger of burning.
- ▶ Danger of burning. Do not store anything which might arouse a child's interest in storage areas above or behind the wok. Otherwise they could be tempted to climb onto the wok.
- ▶ Risk of burning and scalding. Place pots and pans on the cooking zone in such a way that children cannot pull them down and burn themselves.
- ▶ Danger of suffocation! Whilst playing, children may become entangled in packaging material (such as plastic wrapping) or pull it over their head with the risk of suffocation. Keep packaging material away from children.

## Technical safety

- ▶ Unauthorised installation, maintenance or repairs could result in unforeseen dangers for the user, for which the manufacturer cannot accept liability. Installation, maintenance or repairs must only be carried out by a qualified specialist or Miele Customer Service.
- ▶ Damage to the wok can compromise your safety. Check the wok for visible signs of damage. Do not use a damaged wok.
- ▶ Temporary or permanent operation on an autonomous power supply system or a power supply system that is not synchronised with the mains power supply (e.g. island networks, back-up systems) is possible. A prerequisite for operation is that the power supply system complies with the specifications of EN 50160 or an equivalent standard.

The function and operation of the protective measures provided in the domestic electrical installation and in this Miele product must also be maintained in isolated operation or in operation that is not synchronised with the mains power supply, or these measures must be replaced by equivalent measures in the installation. As described, for example, in the current version of BS OHSAS 18001–2 ISO 45001.

- ▶ The electrical safety of this wok can only be guaranteed when correctly earthed. It is essential that this standard safety requirement is met. If in any doubt please have the electrical installation tested by a registered electrical worker.
- ▶ To avoid the risk of damage to the wok, make sure that the connection data on the data plate (voltage and frequency) match the mains electricity supply before connecting it to the mains. Consult a registered electrical worker if in doubt.
- ▶ Do not connect the wok to the mains electricity supply by a multi-socket unit or an extension lead. These do not guarantee the required safety of the appliance (fire hazard).
- ▶ For safety reasons, this wok may only be used after it has been built in.
- ▶ This wok must not be used in a non-stationary location (e.g. on a ship).
- ▶ Never open the casing of the wok.

Touching or tampering with electrical connections or components and mechanical parts is highly dangerous to the user and can cause operational faults.

## Warning and Safety instructions

---

- ▶ While the wok is under warranty repairs should only be undertaken by a Miele authorised service technician. Otherwise the warranty is invalidated.
- ▶ Miele can only guarantee the safety of the appliance when genuine original Miele replacement parts are used. Faulty components must only be replaced by Miele spare parts.
- ▶ The wok is not intended for use with an external timer switch or a remote control system.
- ▶ If the mains connection cable is damaged, it must be replaced with a special mains connection cable by a qualified electrician (see “Electrical connection” in the “Installation” chapter).
- ▶ Connection to the gas supply must be carried out by a registered gas installer. The wok may be connected to the electrical supply by a fused plug and switched socket. If you wish to connect it to a fused spur connection, or if the plug has been removed or the connection cable is not supplied with a plug, the hob must be connected to the mains supply by a registered electrical worker.

## Warning and Safety instructions

---

▶ During installation, maintenance and repair work, the hob must be disconnected from the mains electricity supply. The gas supply must also be shut off. Depending on territory this is done in one of several different ways:

- the mains fuse has been disconnected, or
- the screw-out fuse is removed (if applicable), or
- switch off at the wall socket and withdraw the plug from the socket. Pull by the plug and not by the mains connection cable to disconnect from the mains electricity supply.
- the gas inlet valve is closed.

▶ Danger of electric shock!

Do not use the hob if it is faulty. Shut off the gas supply and contact Miele.

▶ If the wok is built in behind a furniture front (e.g. a door), do not close the door while the wok is in use. Heat and moisture can build up behind the closed door. This can result in damage to the wok, the housing unit and the floor. Leave the furniture door open until the wok has cooled down completely.

▶ In areas which may be subject to infestation by cockroaches or other vermin, pay particular attention to keeping the appliance and its surroundings clean at all times. Any damage caused by cockroaches or other vermin will not be covered by the warranty.

# Warning and Safety instructions

---

## Correct use

- ▶ The wok gets hot when in use and remains hot for some time after being switched off. Do not touch the appliance if there is a possibility that it could still be hot.
- ▶ Do not use the wok to heat up the room.  
Due to the high temperatures radiated, objects left near the wok could catch fire.
- ▶ Overheated fat and oil can ignite and catch fire. Never leave the wok unattended. Do not attempt to extinguish burning oil or fat with water.  
Switch the wok off and carefully smother the flames with a fire blanket or a damp tea towel.
- ▶ Do not leave the wok unattended whilst it is being used. It should be continually monitored whilst boiling and flash frying.
- ▶ Flames could set the grease filters of a cooker hood on fire. Do not flambé under a cooker hood.
- ▶ Spray canisters, aerosols and other inflammable substances can ignite when heated. Therefore do not store such items or substances in a drawer under the wok. Cutlery inserts must be heat-resistant.
- ▶ Do not heat an empty pan.
- ▶ Do not heat up food in closed containers e.g. tins or sealed jars on the wok, as pressure will build up in the container which could cause it to explode.
- ▶ Do not cover the wok, e.g. with a cover, a cloth or protective foil. The material could catch fire, shatter or melt if the appliance is switched on by mistake or if residual heat is still present.
- ▶ If the appliance is switched on by mistake, or if there is residual heat present, there is the risk of any metal items placed on the wok (e.g. cutlery) heating up. Other materials can melt or catch fire. Do not use the appliance as a resting place for anything.
- ▶ You could burn yourself on the hot wok. Protect your hands with heat-resistant pot holders or gloves when handling hot pots and pans. Do not let them get wet or damp, as this causes heat to transfer through the material more quickly with the risk of scalding or burning yourself on steam. Be sure to keep all textiles away from the gas flames. Do not use oversized cloths, tea towels or other similar materials.

## Warning and Safety instructions

---

- ▶ When using an electrical appliance, e.g. a hand-held food blender, near the wok, ensure that the cable of the electrical appliance cannot come into contact with the hot wok. The insulation on the cable could become damaged.
- ▶ Plastic and aluminium foil containers melt at high temperatures. Do not use plastic or aluminium foil containers.
- ▶ When a control knob is pressed down, a spark is generated on the ignitor. Do not press down the control knob while you are cleaning or touching the wok or a burner in the vicinity of an ignitor.
- ▶ A cooker hood installed above the wok can be damaged or catch fire as a result of intense heat. Do not use the wok burner without cookware.
- ▶ Only light the burners after all burner parts have been properly assembled.
- ▶ Pans must be the correct size for the burner they are used on (see „Pans“). A pan which is too small will be unstable on the pan support. If the pan diameter is too large, flames can spread out to the sides and damage or burn the worktop, wall claddings or surrounding units and also parts of the hob. Miele cannot be held liable for this type of damage.
- ▶ Ensure that the flames from the burner do not spread out beyond the base and up the sides of the pan.
- ▶ Do not use pans with very thin bases on this hob, and never heat up empty pans as they could get damaged. This could also damage the appliance.
- ▶ The pan support supplied with the appliance must always be used. Never place a pan on the burner itself.
- ▶ Replace the pan supports carefully to avoid scratching the surface.
- ▶ Do not use or store flammable materials near this appliance.
- ▶ Remove all grease spatters and other combustible (food) residues from the wok burner as soon as possible. They are a fire hazard.
- ▶ Avoid allowing liquids or foods containing salt to spill onto the hob. If salty foods or liquids do get on the hob, they should be removed as soon as possible to avoid the risk of corrosion.

## Warning and Safety instructions

---

- ▶ The use of the wok creates heat, moisture and combustion products in the room where it is installed. Make sure that the appliance is installed in a location with sufficient ventilation. Natural ventilation openings should not be blocked. Alternatively, a mechanical ventilation device (e.g. a cooker hood) can be installed.
- ▶ Prolonged intensive use of the wok may require additional ventilation of the room, e.g., by opening a window, or by operating the cooker hood on a higher setting.
- ▶ If the wok has not been used for a longer period of time, it should be thoroughly cleaned before it is used again. It is also advisable to have it tested by registered gas installer for safety. This should be done at regular intervals.
- ▶ Where several ProLine elements are installed side by side: Hot objects can damage the seal on the spacer bars. Do not place hot pans near or on the spacer bar.

### Cleaning and care

- ▶ Do not use a steam cleaning appliance to clean this wok. The steam could reach electrical components and cause a short circuit.
- ▶ Miele will guarantee to supply functional spare parts for a minimum of 10 years and up to 15 years following the discontinuation of your ProLine element (xxx\_Gaswok\_xxx).

# Caring for the environment

---

## Disposing of the packaging material

The packaging material is used for handling and protects the appliance from transport damage. The packaging material used is selected from materials which are environmentally friendly for disposal and can generally be recycled.

Recycling the packaging material reduces the use of raw materials. Use material-specific collection points for valuable materials and take advantage of return options. Your Miele dealer will take the packaging material away.

## Disposing of your old appliance

Electrical and electronic appliances often contain valuable materials. They also contain specific materials, compounds and components, which were essential for their correct function and safety. These could be hazardous to human health and to the environment if disposed of with your domestic waste or if handled incorrectly. Please do not, therefore, dispose of your old appliance with your household waste.



Please dispose of it at your local community waste collection / recycling centre for electrical and electronic appliances, or contact your dealer or Miele for advice. You are also responsible (by law, depending on territory) for deleting any personal data that may be stored on the appliance being disposed of. Please ensure that your old appliance poses no risk to children while being stored prior to disposal.

## Wok

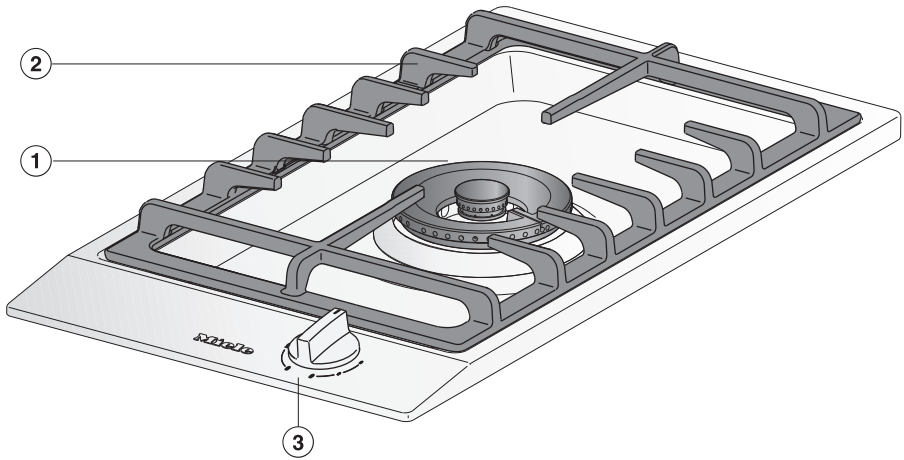

- ① Wok burner
- ② Trivet
- ③ Rotary controls

# Guide to the appliance

---

## Rotary controls

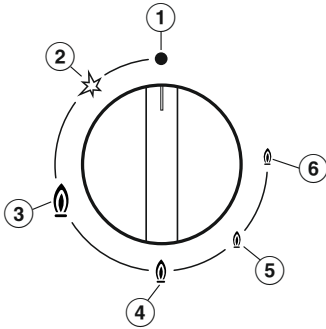

- ① • Burner off  
The gas supply is turned off
- ② ☆ Ignition position
- ③ 🔥 Strongest flame  
The outer and inner burners are on the highest setting
- ④ 🔥 Strong flame  
The outer burner is on the lowest setting, the inner burner on the highest setting
- ⑤ 🔥 Weak flame  
The outer burner is off, the inner burner is on the highest setting
- ⑥ 🔥 Weakest flame  
The outer burner is off, the inner burner is on the lowest setting

## Burner

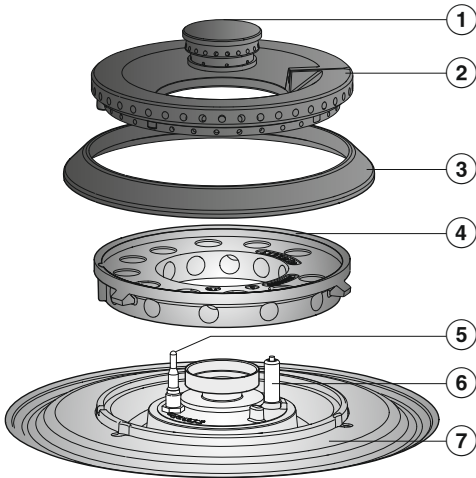

- ① Inner burner cap
- ② Outer burner cap
- ③ Burner ring
- ④ Burner head
- ⑤ Thermocouple
- ⑥ Ignition electrode
- ⑦ Burner base

# Guide to the appliance

---

## Accessories supplied

The accessories supplied with your appliance as well as a range of optional ones are available to order from Miele (see “Optional accessories”).

### Wok ring

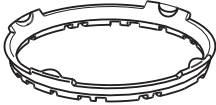

The wok ring supplied gives additional stability to the wok, especially to woks with a rounded base.

### Combination trivet

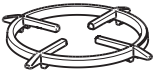

The combination trivet supplied must be used if you are using pans with a smaller base diameter than that specified in the chart for suitable pans.

## Before using for the first time

---

- Please stick the extra data plate for the appliance supplied with this documentation in the space provided in the “After sales service” section of this booklet.
- Remove any protective wrapping and stickers.

### **Cleaning the ProLine element for the first time**

- Clean all removable parts of the burners with a solution of warm water and a small amount of washing-up liquid applied with a soft sponge. Dry all parts thoroughly after cleaning and then reassemble the burners (see “Cleaning and care”).
- Clean the stainless steel trough with a damp cloth, and then wipe dry.

### **Switching on the ProLine element for the first time**

The metal components have a protective coating. When the hob is used for the first time, this causes a smell and possibly also vapour.

The smell and any vapours given off do not indicate a faulty connection or appliance and they are not hazardous to health.

## Pans

Minimum cookware base diameter [cm]	
Pots/pans	15

Maximum diameter at top of cookware [cm]	
Pots/pans	28
Wok pan	40

- Observe the dimensions given in the chart. Using pans that are too large can cause the flames to spread out and damage the surrounding worktop or other appliances. Using pans of the correct size improves efficiency. Pans that are smaller than the trivets and pans that do not stand safely (without wobbling) on the trivets are dangerous and should not be used.
- Make sure that the base of the wok pan is not touching the burner. There must be a gap of at least 1 cm between the burner and the base of the pan.
- Remember when purchasing new pans that manufacturers usually refer to the diameter at the top of the pan in their documentation, and not to the base diameter.
- You can use any cookware that is heat-resistant.
- Cookware with a thick base is preferable as the heat is distributed evenly. With thin bases, there is the risk that food will overheat in places. Therefore it should be stirred more frequently.
- Always place the cookware on the trivet supplied. Do not place cookware directly on the burners.

- Place the cookware on the trivet in such a way that it cannot tip over. A little movement is quite normal and not a cause for concern.



- Do not use pots or pans with an edge-supported base.

## Wok ring

- Use the wok ring supplied to give additional stability to cookware, especially to wok pans with a rounded base.

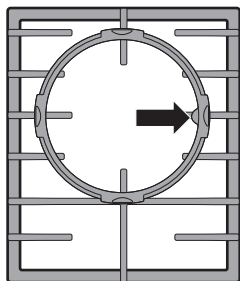

- Place the wok ring on the trivet so that it sits securely in position and cannot move (see diagram).

## Combination trivet

The combination trivet must be used if you wish to use a pan with a smaller diameter base than the minimum given in the table.

## Tips on saving energy

---

- Use a pan lid whenever possible to minimize heat loss.

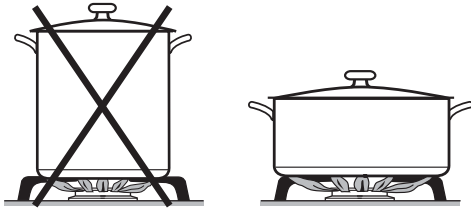

- Wide, shallow pans are preferable to tall, narrow ones. They will heat up faster.
- Cook with as little water as possible.
- Reduce the size of the flame once the water has come to the boil or the oil is hot enough to fry in.
- Use a pressure cooker to reduce cooking times.

 Risk of fire with overheated food. Unattended food can overheat and catch alight. Do not leave the hob unattended whilst it is being used.

## Switching on

- Push in the control knob and turn it anti-clockwise to the ignition symbol . The ignitor will „click“ and ignite the gas.
- When a flame is visible, keep the control knob pressed in for 5-10 seconds, and then let it go. Do not keep the knob pressed longer than 15 seconds.
- If the burner does not ignite after 15 seconds, turn the control knob back to „•“. Air the room or wait at least one minute before trying again.
- If the burner does not ignite the second time, turn the control knob back to „•“ and see „Problem solving guide“.

## Flame goes out during operation

- If the flame goes out, for example because food has boiled over or if there has been a sudden draught, turn the control knob to „•“.
- Wait at least one minute before trying ignite the burner again.

## Switching on during a power outage

If there is an interruption to the electricity supply, the gas can be ignited manually, e.g. with a match.

- Press in the relevant control and turn it anti-clockwise to the ignition position .
- Hold the control pressed in and light the gas at the burner with a match.
- Keep the control pressed in for a further 5-10 seconds and then release it.

# Operation

---

## Adjusting the flame

As the outer part of the flame is much hotter than the centre, the tips of the flames should stay beneath the pan base. Flame tips which extend beyond the sides of the pan merely warm up the air in the room and can also damage pan handles and increase the risk of injury.

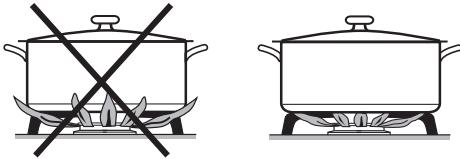

There is a resistance at the 6 o'clock position to prevent you turning the control to the high or low setting unintentionally. Press the control knob down to move past this resistance.

- Adjust the flame so that it does not spread out beyond the sides of the pan.
- To move from the high to the low setting, turn the control anti-clockwise until it meets a resistance. Then press it down and continue to turn it past the resistance before releasing it. You can now select the setting you require.
- To move from the low to the high setting, turn the control clockwise until it meets a resistance. Then press it down and continue to turn it past the resistance before releasing it. You can now select the setting you require.

## Switching off

- Turn the rotary control clockwise to  
• burner off.

The gas supply is cut off and the flame goes out.

### **Thermo-electric flame failure monitor**

This wok has a thermo-electric flame failure monitor. If the flame goes out, for example because food has boiled over or if there has been a sudden draught, the supply of gas to the burner will be cut off. This will prevent any gas escaping. To use the burner again, turn the control knob to „●“.

In the event of the burner flames being accidentally extinguished, turn off the burner control and do not attempt to re-ignite the burner for at least 1 min.

The thermo-electric flame failure monitor operates independently from the electricity supply. This means that it will still work if the wok burner is used during a power cut.

## Cleaning and care

---

 Danger of burning due to hot surfaces.

The surfaces will be hot after cooking.

Switch the wok off.

Allow the surfaces to cool down before cleaning the wok.

 Risk of damage due to moisture ingress.

The steam from a steam cleaning appliance could reach live electrical components and cause a short circuit.

Do not use a steam cleaner to clean the wok.

All surfaces could be discoloured or damaged if unsuitable cleaning agents are used. All surfaces are susceptible to scratching.

Remove all cleaning agent residues immediately.

Never use abrasive sponges or cleaning agents.

Food boiling over can cause discoloration of the burner components.

Remove any soiling and salt and sugar splashes immediately.

When a control knob is pressed down, a spark is generated on the ignitor. Do not press down the control knob while you are cleaning or touching the wok or a burner in the vicinity of an ignitor.

- cleaning agents containing soda, alkalines, ammonia, acids or chlorides
- cleaning agents containing descaling agents
- stain and rust removers
- abrasive cleaning agents, e.g. powder cleaners and cream cleaners
- solvent-based cleaning agents
- dishwasher cleaner
- oven sprays
- glass cleaning agents
- hard, abrasive brushes or sponges (e.g. pot scourers), or sponges which have been previously used and still contain abrasive cleaning agents
- melamine eraser blocks

### Unsuitable cleaning agents

To avoid damaging the surfaces of the appliance, do not use:

Allow the ProLine element to cool down before cleaning.

- Clean the ProLine element and accessories after each use.
- Dry the ProLine element thoroughly after cleaning it with water to avoid limescale residue.

### Cleaning the stainless steel trough

 Risk of damage by pointed objects.

The seal between the hob and the worktop could suffer damage. Do not use pointed objects for cleaning.

 Damage caused by soiling. Soiling, particularly salty food or liquid and olive oil, can cause damage if left on the printed surfaces for a long time.

Remove such soiling immediately.

 Damage caused by incorrect cleaning.

Stainless steel cleaning agents rub off the printed symbols.

Do not use stainless steel cleaning agents on printed symbols.

- Clean stainless steel surfaces using a solution of warm water and a little washing-up liquid applied with a soft sponge. Soften any stubborn soiling beforehand. If necessary, the rough side of a non-scouring sponge can be used.
- Finally, dry with a clean soft cloth.

## Cleaning and care

---

### Cleaning the rotary controls

- Clean the rotary control(s) using a solution of warm water and a little washing-up liquid applied with a soft sponge. Soften any stubborn soiling beforehand.
- Dry the control(s) with a clean cloth.

### Cleaning the trivets

- Remove the trivets.
- Clean the trivets in a dishwasher or with a solution of warm water and a little washing-up liquid applied with a soft sponge. Soften any stubborn soiling beforehand.
- Dry the trivets thoroughly with a clean cloth.

### Cleaning the wok ring/ combination trivet

- Clean the wok ring/combination trivet in a dishwasher or with a solution of warm water and a little washing-up liquid applied with a soft sponge. Soften any stubborn soiling beforehand.
- Dry the wok ring/combination trivet thoroughly with a clean cloth.

## Cleaning the burners

### Cleaning the burners

Do not clean any parts of the burners in a dishwasher.

- Remove all loose components of the burners and clean only by hand using a solution of warm water and a little washing-up liquid applied with a soft sponge.

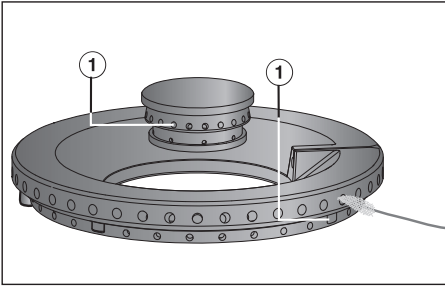

- Clean any soiling from the flame openings ① with the brush supplied.

### ⚠ Danger of explosion!

Blocked flame openings can cause a dangerous build-up of gas in the base of the hob which could ignite and cause an explosion. This can lead to damage to the appliance and injury. Ensure the flame openings are kept clean at all times.

- Parts of the burner that cannot be removed should be wiped clean with a damp cloth only.
- The ignitor and thermocouple should be very carefully wiped clean using a well wrung out cloth.

The ignitor must not get wet, otherwise it will not spark.

- Finally dry everything thoroughly with a clean cloth. Make sure that the flame openings are completely dry.

The surface of the burner cap will become duller with time. This is completely normal and does not indicate material deterioration.

# Cleaning and care

## Assembling the burners

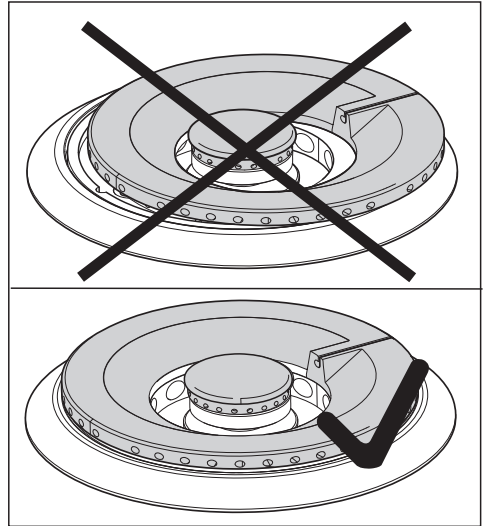
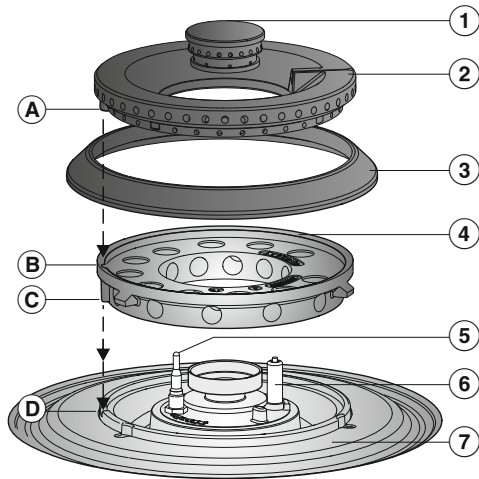

- Place burner head ④ on to burner base ⑦ so that the thermocouple ⑤ and the ignitor ⑥ extend through their respective holes in the burner head. The lobes ① on the burner cap must fit into the recess ② on the burner head. The lobes ③ on the burner head must fit into the recess ④ on the burner base.
- Replace the burner ring ⑤.
- Then place the burner caps ① and ② in position.

**⚠** The burners cannot function correctly if they are incorrectly assembled. This can lead to damage to the appliance and injury. Ensure that all parts of the burner are reassembled in the correct order.

### Functional check

- Ignite all burners to check that they are burning correctly:
  - The flame must not go out on the lowest setting, or when the control is turned quickly from the highest to the lowest setting.
  - On the highest setting, the flame must have a distinctive and visible core.

## Problem solving guide

Many malfunctions and faults that can occur in daily operation can be easily remedied. You can save time and money in many cases, as you do not need to call the Miele Customer Service Department.

Information to help you rectify faults yourself can be found at [www.miele.com/service](http://www.miele.com/service).

The following tables are designed to help you to find the cause of a malfunction or a fault and to resolve it.

Problem	Cause and remedy
<b>The burners do not ignite when the hob is being used for the first time or after it has been out of use for a longer period.</b>	There could be an air lock in the gas pipe. <ul style="list-style-type: none"> <li>■ You may need to make several attempts before the burner ignites successfully.</li> </ul>
<b>The burner does not light after several attempts.</b>	There is a technical fault. <ul style="list-style-type: none"> <li>■ Turn all of the rotary controls clockwise to • burner off and interrupt the power supply to the hob for a few seconds.</li> </ul>
	The burner is not correctly assembled. <ul style="list-style-type: none"> <li>■ Assemble the burner correctly.</li> </ul>
	The gas shut-off device has not been opened. <ul style="list-style-type: none"> <li>■ Open the gas shut-off device.</li> </ul>
	The burner is wet and/or dirty. <ul style="list-style-type: none"> <li>■ Clean and dry the burner.</li> </ul>
	The flame openings are blocked and/or wet. <ul style="list-style-type: none"> <li>■ Clean and dry the flame openings.</li> </ul>
<b>The gas flame goes out after ignition.</b>	The flames do not touch the thermocouple and the burner does not get hot enough: The burner parts are not positioned correctly. <ul style="list-style-type: none"> <li>■ Assemble the burner components correctly.</li> </ul>
	The thermocouple is dirty. <ul style="list-style-type: none"> <li>■ Remove any soiling.</li> </ul>
<b>The flame suddenly looks different.</b>	The burner parts are not positioned correctly. <ul style="list-style-type: none"> <li>■ Position the burner parts correctly.</li> </ul>
	The burner head or the holes in the burner cap are dirty. <ul style="list-style-type: none"> <li>■ Remove any soiling.</li> </ul>

## Problem solving guide

Problem	Cause and remedy
<b>The gas flame goes out during use.</b>	The burner parts are not positioned correctly. ■ Position the burner parts correctly.
<b>The ignitor on the burner does not spark.</b>	The mains fuse has tripped. ■ You may need to contact a registered electrical worker or Miele.
	There is food residue stuck between the ignitor and the burner cap. There is food residue on the thermocouple. ■ Remove any soiling (See „Cleaning and care“).

## Optional accessories

---

Miele offers a comprehensive range of useful accessories as well as cleaning and conditioning products for your Miele appliances.

These products can be ordered through the Miele online shop.

They can also be ordered from the Miele Customer Service Department (see end of these operating instructions for contact details) or from your Miele dealer.

### **Ceramic and stainless steel hob cleaner 250 ml**



Removes heavy soiling, limescale deposits and aluminium residues

### **Microfibre cloth**

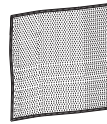

Removes finger marks and light soiling

### Contact in the event of a fault

In the event of any faults which you cannot remedy yourself, please contact your Miele dealer or the Miele Customer Service Department.

You can book a Miele Customer Service Department call-out online at [www.miele.com/service](http://www.miele.com/service).

Contact information for the Miele Customer Service Department can be found at the end of this document.

Please quote the model identifier and serial number of your appliance (Fabr./SN/Nr.) when contacting the Miele Customer Service Department. This information can be found on the data plate.

Please note that telephone calls may be monitored and recorded for training purposes and that a call-out charge will be applied to service visits where the problem could have been resolved as described in this booklet.

### Data plate

Stick the extra data plate supplied with the appliance here. Make sure that the model identifier matches the one specified on the back cover of this document.

### Guarantee

For information on the appliance guarantee specific to your country please contact Miele. See end of this booklet for contact details.

# Installation

---

## Safety instructions for installation



Risk of damage from incorrect connection.

Incorrect installation can cause damage to the ProLine element.

The ProLine element must only be installed by a qualified person.



Damage from falling objects.

Take care not to damage the ProLine element when fitting wall units or a cooker hood above it.

Fit the wall units and the cooker hood before the ProLine element.

- ▶ The room in which the ProLine element is installed must conform to all relevant local and national building and safety regulations.
- ▶ The veneers or laminate coatings of worktops must be treated with 100 °C heat-resistant adhesive so they do not come loose or warp. Any wall strips must be of heat-resistant material.
- ▶ A deep fat fryer must not be installed directly next to a gas hob or a wok burner as the gas flames could ignite the fat in the fryer. It is essential to maintain a distance of at least 288 mm between these two appliances.
- ▶ The ProLine element (xxx\_Gaswok\_xxx) must not be installed over a refrigeration appliance, dishwasher, washing machine, washer-dryer or tumble dryer.
- ▶ When installing the ProLine element, make sure that the gas pipe and mains connection cable cannot come into contact with hot appliance parts.
- ▶ The mains connection cable and any flexible gas connection pipes must be installed in such a way so that they do not come into contact with any moving kitchen parts (e.g. a drawer) after the ProLine element has been installed, and that they cannot be subjected to any mechanical action which could cause damage.
- ▶ Observe the safety clearances listed on the following pages carefully.

## Safety distances

### Safety distance above the CombiSet

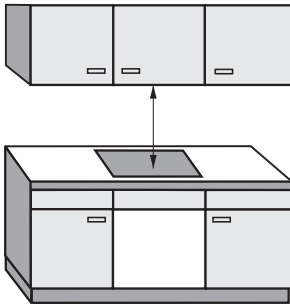

A minimum safety distance must be maintained between the CombiSet and the cooker hood above it. See the cooker hood manufacturer's operating and installation instructions for details. If the manufacturer's instructions are not available for the cooker hood a minimum safety distance of at least 760 mm must be maintained, or if any flammable objects (e.g. utensil rails, wall units etc) are installed above the CombiSet, a minimum safety distance of at least 760 mm must be maintained between them and the CombiSet below.

When two or more CombiSets which have different safety distances are installed together below a cooker hood, you should observe the greatest safety distance.

### Safety Distance below the appliance

There should be at least 30 mm height or plenty of space reserved below the appliance for the installation of the flexible gas connection pipe and electrical cable. It also avoids any possible hindrance towards the movement of all moveable kitchen parts (e.g. drawer).

# Installation

## Safety distances to the sides and back of the appliance

Ideally the ProLine element should be installed with plenty of space on either side.

The minimum safety distance ① shown below must be maintained between the back of the ProLine element and a tall unit or wall.

The minimum safety distance ②, ③ shown below must be maintained between a tall unit or a wall to the left or right of the ProLine element with a minimum safety distance of 300 mm on the opposite side.

① Minimum distance between the **back** of the worktop cut-out and the rear edge of the worktop: 50 mm

② Minimum distance between the worktop cut-out and a wall or tall unit to the **right** of it: 250 mm.

③ Minimum distance between the worktop cut-out and a wall or tall unit to the **left** of it: 250 mm.

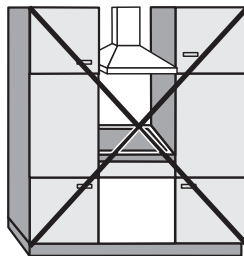

Not allowed

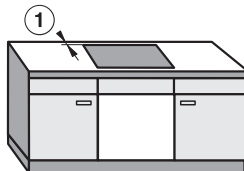

Highly recommended

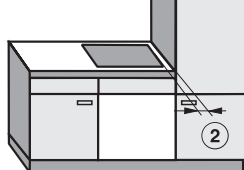

Not recommended

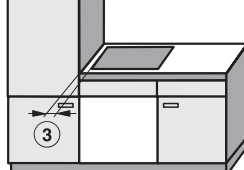

Not recommended

## Safety distance to niche cladding

If niche cladding is installed, a minimum safety distance must be maintained between the worktop cut-out and the cladding, since high temperatures can alter or damage these materials.

If the niche cladding is made from a combustible material (e.g. wood), a minimum safety distance ⑤ of 70 mm must be maintained between the worktop cut-out and the cladding.

If the niche cladding is made from a non-combustible material (e.g. metal, natural stone, ceramic tiles), the minimum safety distance ⑤ between the worktop cut-out and the cladding will be 70 mm minus the thickness of the cladding.

Example: 15 mm thick niche cladding

70 mm - 15 mm = minimum safety distance of 55 mm

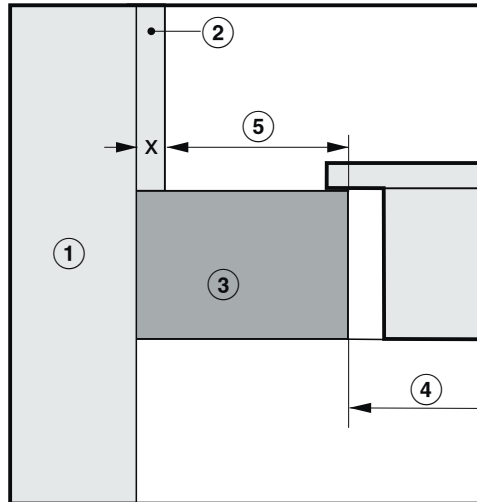

- ① Masonry
- ② Niche cladding dimension x = thickness of the niche cladding material
- ③ Worktop
- ④ Worktop cut-out
- ⑤ Minimum safety distance to  
**combustible** materials 50 mm  
**non-combustible** materials 50 mm - dimension x

# Installation

## Installation notes

### Sealing between the ProLine Element and the worktop

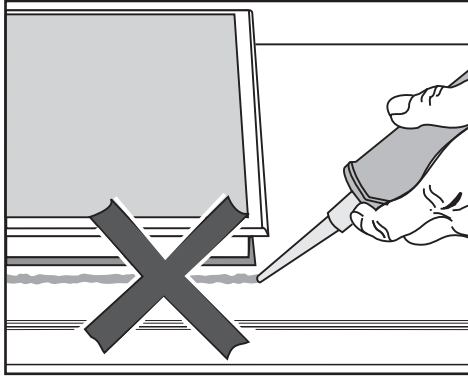

Damage caused by incorrect installation.

The ProLine element and worktop may be damaged if the ProLine element needs to be removed after it has been sealed with a sealant.

Do not use any sealant between the ProLine element and the worktop.

The sealing strip under the edge of the top part of the appliance provides a sufficient seal for the worktop.

### Sealing strip

Dismantling the ProLine element for service purposes may damage the sealing strip underneath the edge of the ProLine element.

Always replace the sealing strip before reinstalling the ProLine element.

### Tiled worktop

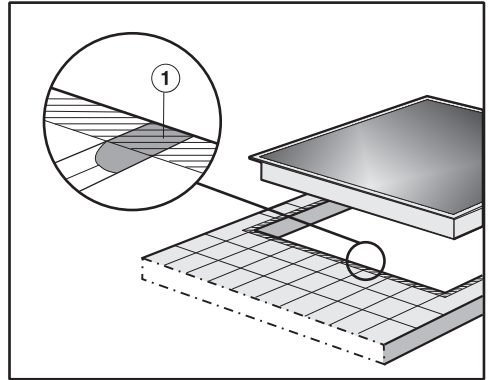

Grout lines ① and the hatched area underneath the ProLine element frame must be smooth and even. If they are not, the ProLine element will not sit flush with the worktop and the sealing strip underneath the top part of the appliance will not provide a good seal between the appliance and the worktop.

## Building-in dimensions

All dimensions are given in mm.

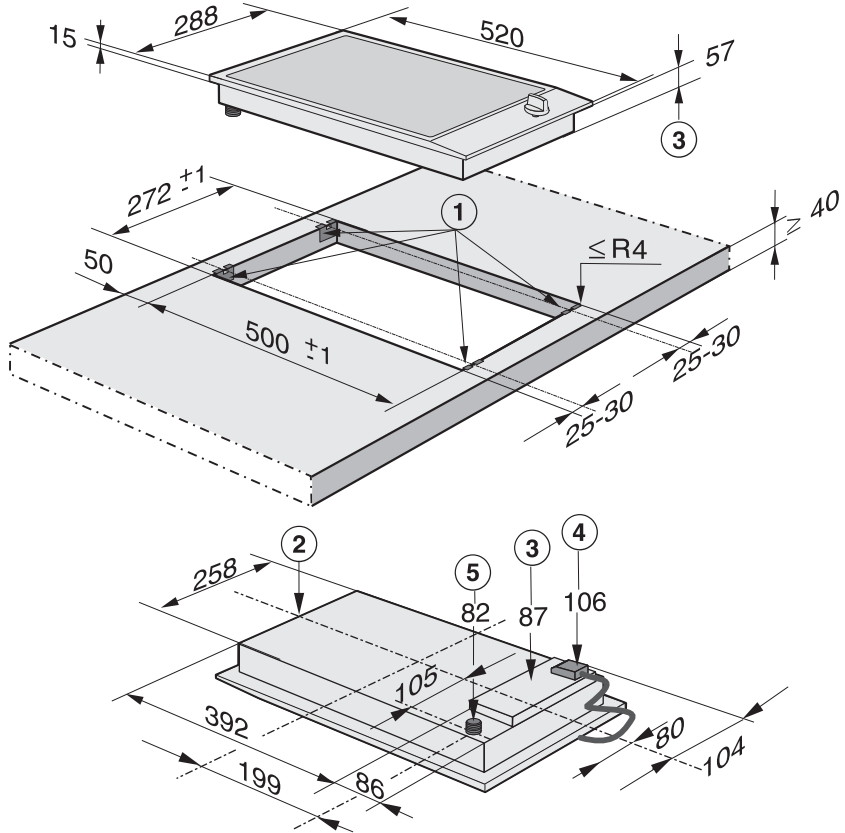

- ① Spring clamps
- ② Front
- ③ Casing depth
- ④ Total height of the ProLine element (xxx\_Gaswok\_xxx) with mains connection box  
Mains connection cable L = 2.000 mm
- ⑤ Casing depth for gas connection R 1/2"

# Installation

## Worktop cut-out for several ProLine elements

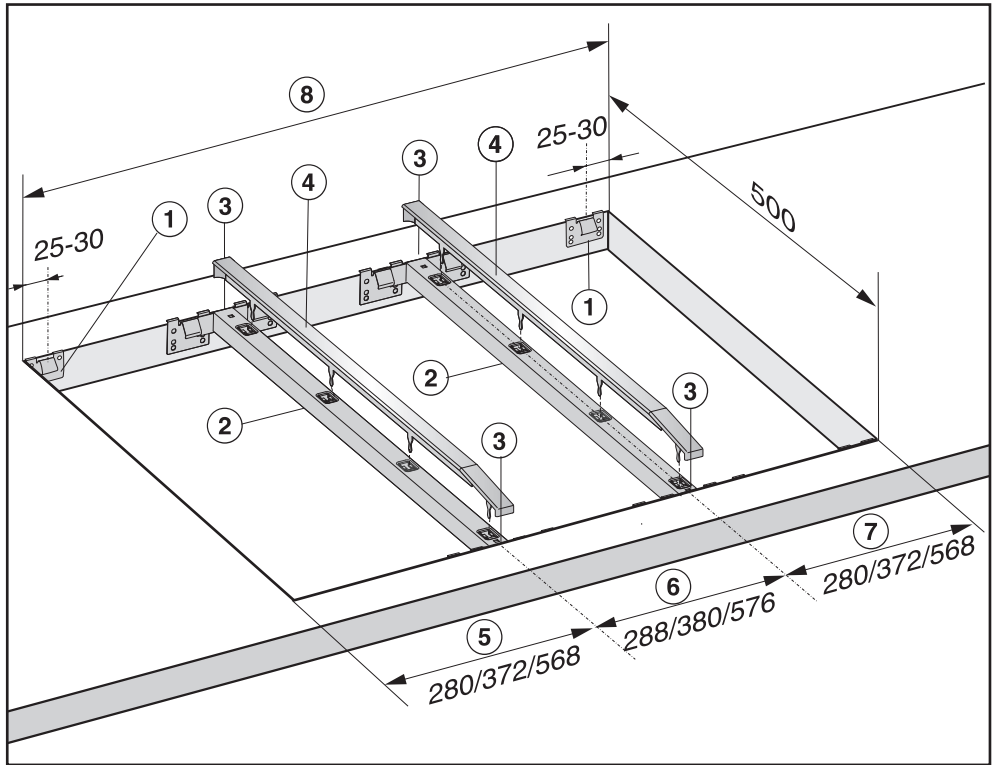

Example: 3 ProLine elements

- ① Spring clamps
- ② Spacer bars
- ③ Gap between spacer bars and worktop
- ④ Cover
- ⑤ ProLine element width minus 8 mm
- ⑥ ProLine element width
- ⑦ ProLine element width minus 8 mm
- ⑧ Worktop cut-out

## Calculating the worktop cut-out

The frames of the ProLine elements overlap the worktop at the outside right and left by 8 mm on each side.

- Add up the widths of the ProLine elements and subtract 16 mm from this figure.

Example:

$$288 \text{ mm} + 288 \text{ mm} + 380 \text{ mm} = 956 \text{ mm} - 16 \text{ mm} = 940 \text{ mm}$$

The ProLine elements are 288 mm, 380 mm or 576 mm wide depending on the ProLine elements (see “Building-in dimensions” in the “Installation” chapter).

## Spacer bars

When installing several ProLine elements, an additional spacer bar must be fitted in between the individual ProLine elements. The position for securing the spacer bar will depend on the width of the ProLine element.

# Installation

## Installation

### Preparing the worktop

- Make the worktop cut-out as shown in “Installation dimensions” or as calculated (see “Installation – Installing several ProLine elements”). Remember to maintain the minimum safety distances (see “Installation – Safety distances”).
- Seal any cut surfaces on **wooden worktops** with a special varnish, silicone sealant or resin to prevent the wood from swelling as a result of moisture ingress. The sealant must be heat-resistant.

Make sure that the sealant does not come into contact with the top of the worktop.

The seal under the appliance ensures that the hob will sit securely in the cut-out without slipping. Any gap between the appliance frame and worktop will become smaller over time.

### Securing the spring clamps and spacer bars – wooden worktops

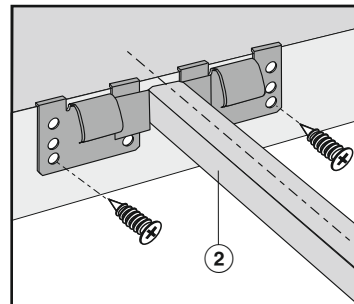
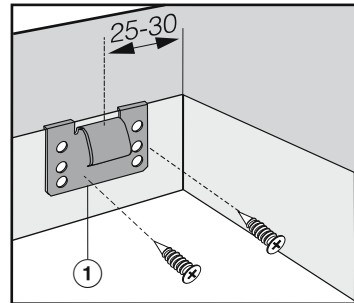

- Position the spring clamps ① or spacer bars ② at the top edge of the cut-out in the positions shown in the illustrations.
- Secure the spring clamps ① or spacer bars ② with the 3.5 x 25 mm wood screws supplied.

## Securing the spring clamps and spacer bars – granite and marble worktops

You will need heavy-duty double-sided tape (not supplied) to secure the spring clamps or spacer bars.

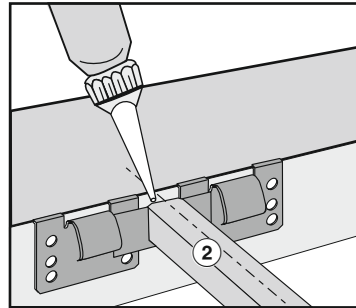
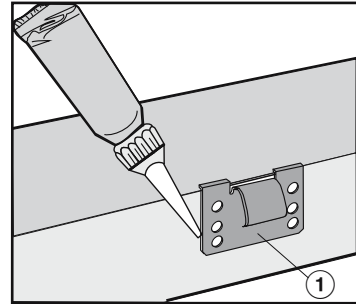
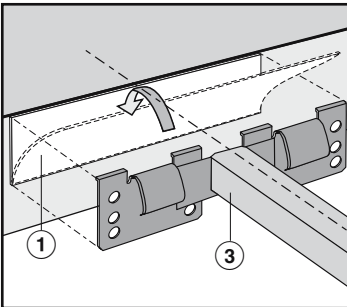
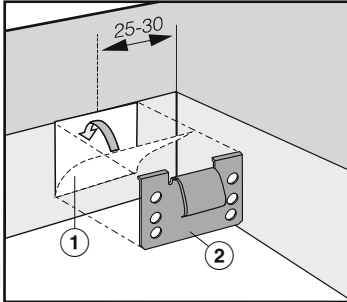

- Attach the adhesive tape ① along the top edge of the cut-out in the positions shown in the hob illustration.
- Position the spring clamps ② or spacer bars ③ on the top edge of the cut-out and press them firmly into place.

- Apply silicone to the side and lower edges of the spring clamps ① or spacer bars ②.
- Then fill the gap ⑤ between the spacer bars ② and the worktop with silicone.

# Installation

## Fitting the ProLine element

- Feed the mains connection cable down through the worktop cut-out.
- Starting at the front, position the ProLine element in the worktop cut-out.
- Using both hands, press down evenly on the sides of the ProLine element until it clicks into position. When doing this make sure that the seal of the appliance sits flush with the worktop on all sides. This is important to ensure an effective seal all round the worktop.

Do not use any additional sealant (e.g. silicone) on the ProLine element.

If the seal does not sit flush with the worktop in the corners, the corner radius ( $\leq R4$ ) can be carefully cut to fit using a jigsaw.

## Installing several ProLine elements

- Push the built-in ProLine element to the side until the holes in the spacer bar can be seen.

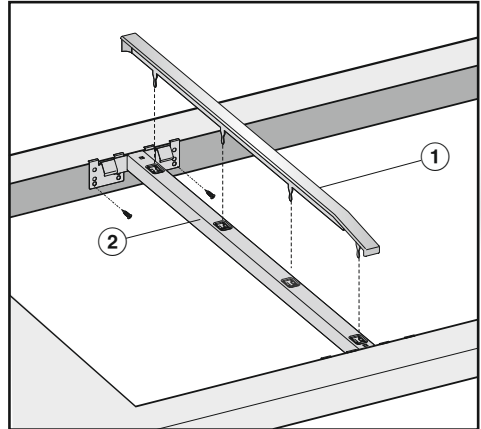

- Push the cover strip ① into the designated holes in the spacer bar ②.
- Starting at the front, position the next ProLine element in the worktop cut-out.
- Proceed as described previously.

## Connecting the ProLine element

- Connect the ProLine element/elements to the electricity supply and to the gas supply (see “Installation – Electrical connection” and “Gas connection”).

## Functional check

- After installing the hob, ignite all burners to check that they are operating correctly:
  - The gas flame must not go out on the lowest setting, or when the rotary control is turned quickly from the highest to the lowest setting.
  - On the highest setting, the gas flame must have a distinctive and visible core.

## Removing a ProLine element

- If the ProLine element is accessible from below, push it upwards to remove it. Push the back of the appliance out first.
- If the ProLine element is not accessible from below, take hold of the appliance with both hands at the back, pull it forwards, then lift it up and out.

# Installation

## Gas connection

 According to the Gas Safety (Registration of Gas Installers and Gas Contractors) Regulations, any gas installation work including the installation of appliances and connecting tubing, must be undertaken by a registered gas installer who is registered for that appropriate class and is employed by a registered gas contractor. The installer is responsible for ensuring that the appliance functions correctly when installed.

Use approved gas tubing for connection to appliances.

The gas connection must be installed so that connection can be made either from inside or outside the kitchen unit. The isolating valve must be easily accessible and visible (by opening the kitchen door if necessary).

Check with your local gas supplier about the type of gas its calorific value and compare this information with the type of gas quoted on the appliance's data plate.

This hob is not connected to an exhaust flue.  
When installing and connecting the appliance please observe all relevant installation instructions and ensure it has adequate ventilation once installed.

Connection to the gas supply must be carried out in strict accordance with current local regulations. Every appliance should have its own easily accessible isolating valve and test point.

Any special local conditions relating to gas installations as well as building regulations must also be observed.

Gas connections, pipes and connection cables can suffer damage if exposed to heat from the hob. After installation make sure that neither the gas pipe nor the mains cable can come into contact with hot parts of the appliance and that the gas pipe and connections on the hob cannot come into contact with hot gas exhaust.

Flexible gas pipes can be damaged by incorrect routing. Attach flexible gas pipes in such a way so that they do not come into contact with any moving kitchen parts (e.g. a drawer) and are not exposed to mechanical stress.

The hob must be set for local gas conditions and the gas connection must undergo a leakage test.

Depending on country of destination this appliance is set up for connection to Natural gas, Liquefied Petroleum gas (LPG) or Town gas (TG). See adhesive label on the appliance.

Depending on country, a set of jets for conversion to an alternative type of gas may be included with the hob. Please contact your supplier or Miele for the appropriate conversion jets if necessary. Conversion to another type of gas is described under „Conversion to another type of gas“.

## Inlet pressure

Natural gas	20 mbar
LPG	29 mbar
Town gas	10 mbar

## Connecting the hob

The hob is supplied with a conical 1/2" gas connection point for connection to one of the following:

- Rigid connection with isolation valve
- Flexible connection, maximum length 2000 mm.

Unsuitable sealants may not be leak-proof.

Connections must be sealed using appropriate sealant.

- After installation, turn on the gas supply and use soap solution to check for gas leakage.

Never use a naked flame!

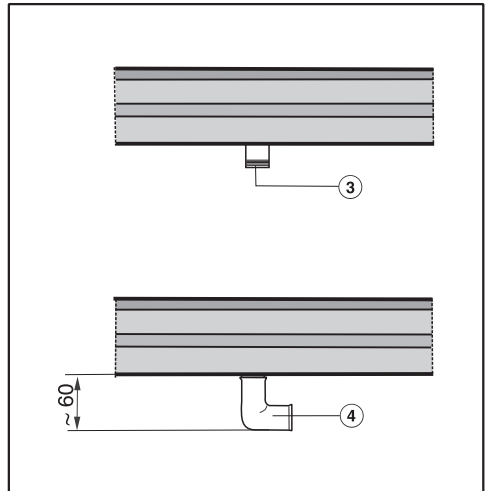

③ Connection R 1/2"

④ 90° bend

⚠ According to the Gas Safety (Registration of Gas Installers and Gas Contractors) Regulations, any gas installation work including the installation of appliances and connecting tubing, must be undertaken by a registered gas installer who is registered for that appropriate class and is employed by a registered gas contractor.

# Installation

---

## LP Gas Connection - elbow joint connection

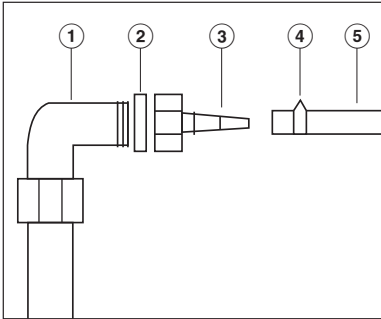

- ① Elbow joint
- ② Gasket
- ③ Nozzle
- ④ Ring
- ⑤ Rubber hose

The gasket depicted above is to prevent gas leakage.

## Burner ratings

### Nominal ratings

Gas type	Highest setting		Lowest setting
	kW	g/h	kW
Natural gas	5.2	–	0.25
Liquefied Petroleum gas	4.8	350	0.2
Town gas	4.8	–	0.2

### Nominal ratings CS 1018 G (For Malaysia market)

Gas type	Inlet pressure	Highest setting		Lowest setting
	mbar	kW	g/h	kW
Natural gas	20	–	–	–
LPG (G30)	29	5.0	364	0.2
Town gas	10	–	–	–

# Installation

---

## Electrical connection

The ProLine element is supplied with a mains cable with moulded plug ready for connection to a suitable earthed socket.

The socket must be easily accessible after the ProLine element has been installed. If the socket is not easily accessible, ensure that a suitable means of disconnection is provided on the installation side for each pole.

 Risk of fire from overheating. Connecting the ProLine element to multi-socket adapters or extension cables can overload the cables. For safety reasons, do not use an extension cable or multi-socket adapter.

The electrical installation must comply with BS 7671 requirements.

For safety reasons, we recommend using a type  residual current device (RCD) in the relevant electrical installation for connecting the ProLine element.

If the mains connection cable is damaged, it must only be replaced with a specific mains connection cable of the same type (available from the Miele Customer Service Department). For safety reasons, such replacement may only be carried out by a qualified specialist or the Miele Customer Service Department.

These operating instructions and the data plate indicate the nominal power consumption and the appropriate fuse rating. Compare this information with the data of the on-site electrical connection.

If in any doubt, consult a qualified electrician.

Temporary or permanent operation on an autonomous power supply system or a power supply system that is not synchronised with the mains power supply (e.g. island networks, back-up systems) is possible. A prerequisite for operation is that the power supply system complies with the specifications of EN 50160 or an equivalent standard. The function and operation of the protective measures provided in the domestic electrical installation and in this Miele product must also be maintained in isolated operation or in operation that is not synchronised with the mains power supply, or these measures must be replaced by equivalent measures in the installation. As described, for example, in the current version of BS OHSAS 18001–2 ISO 45001.

# Converting to another gas type

 Risk of explosion due to an incorrect conversion.

If the conversion to another type of gas is carried out incorrectly, it may result in gas leakage.

Conversion from one type of gas to another must only be undertaken by an approved and registered gas installer in strict accordance with current local and national safety and building regulations. The installer is responsible for ensuring that the appliance functions correctly when installed.

## Jet table

The markings on the jets refer to a 1/100 mm bore diameter.

The following table indicates the jet sizes in mm.

	Ø	
	Main jet	Simmer adjustment jet
<b>Natural gas</b>	1.6/ 0.58 (R)	0.7/ 0.38
<b>Liquefied Petroleum gas</b>	1.05/ 0.34 (E)	0.6/ 0.23
<b>Town gas</b>	3.8 1.0 (H)	0.9 0.54

## Changing the jets

- Disconnect the hob from the electricity supply and turn off the gas supply.

When converting to another type of gas, both the main **and** small jets need to be changed.

The external gas governor delivered with the appliance should not be installed when using Liquid gas or Natural gas.

## Removing the upper part of the appliance

You must remove the top of the appliance to change the jets.

- Pull the rotary controls up and off to remove them.
- Remove the loose burner components.
- Loosen the fixing screws on the burners.
- Lift the upper part of the appliance off to remove it.

# Converting to another gas type

## Changing the outer burner main jet

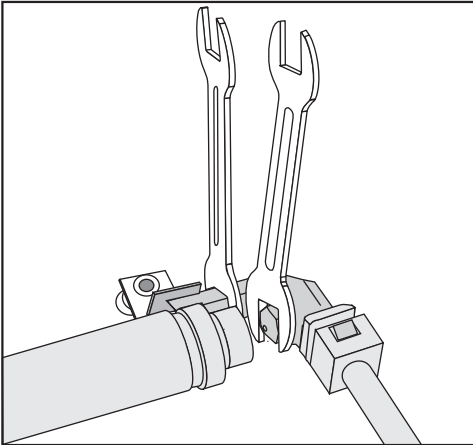

- Use an open spanner (SW 10) to rotate the main jet anti-clockwise out of the jet holder. Use another open spanner (SW 13) for support while you are doing this (see illustration).
- Fit the new jet (see jet table) and rotate it into place, using the open spanner for support again.
- Secure the jets against inadvertent loosening with sealing wax.

## Checking the first intake of air

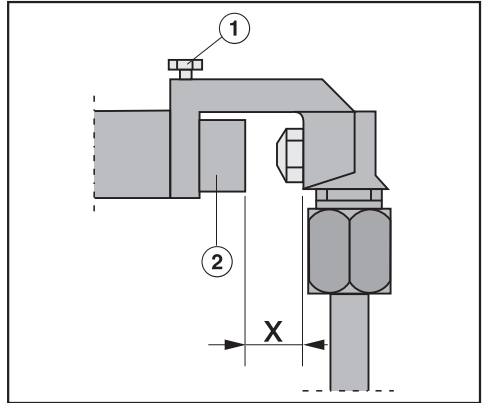

① Adjustment screw

② Air intake sleeve

Gap X **must** measure:

For Natural gas: 6 mm

For Liquefied Petroleum gas: 13 mm

For Town gas: 13 mm

### To set gap X

- Loosen screw ① and slide the air intake sleeve ②.
- Then retighten the screw.

# Converting to another gas type

## Changing the inner burner main jet

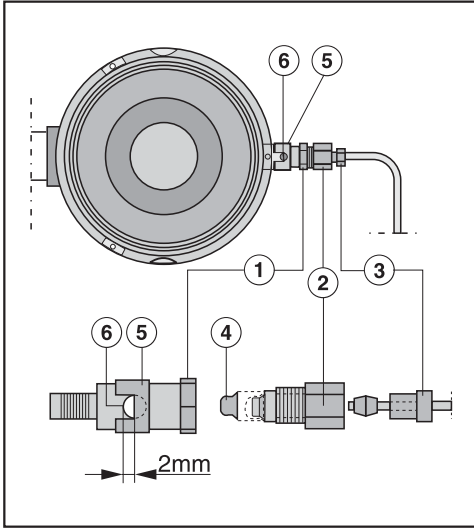

- ④ Small jet plate (main jet for inner burner)
  - ⑤ Air intake sleeve
  - ⑥ Air opening
- Use an open spanner (SW 8) to rotate the screw ③ out of the screw part ②. Use another open spanner (SW 12) for support while you are doing this.
  - Use an open spanner (SW 12) to rotate the screw part ② out of part ①. Use another open spanner (SW 12) for support while you are doing this.
  - Remove the small jet plate ④ from the part ① and insert the new small jet plate (see jet table).
  - Adjust the two air openings ⑥ by moving the air intake sleeve ⑤ so that a distance of 2 mm remains.
  - Tighten all the parts in reverse order and check for leaks.

## Changing the small jets

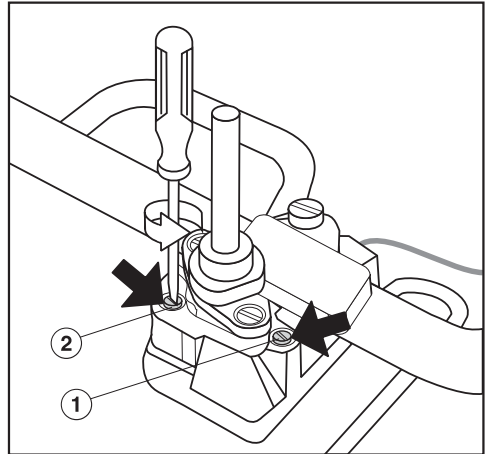

- ① Small jet with smaller diameter (e.g. for liquid gas: 0.23)
  - ② Small jet with larger diameter (e.g. for liquid gas: 0.60)
- Using a small screwdriver, unscrew the two small jets in the gas fitting.
  - Pull out the jets with a pair of pointed pliers.
  - Fit the correct jets securely (see jet table).
  - Secure the jets against inadvertent loosening with sealing wax.

# Converting to another gas type

---

## Functional check

- Check all gas fittings for leaks.
- Reassemble the hob.
- Ignite all burners to check that they are operating correctly.
  - The flame must not go out on the lowest setting, or when the control is turned quickly from the highest to the lowest setting.
  - On the highest setting, the flame must have a distinctive and visible core.
- Adhere the label supplied with the jets, stating the type of gas being used.

**Singapore**

Miele Pte. Ltd.  
29 Media Circle  
#11-04 ALICE@Mediapolis  
Singapore 138565  
Tel.: +65-67351191  
Fax: +65-67351161  
E-mail: info@miele.com.sg  
Website: www.miele.sg

**Malaysia**

Miele Sdn Bhd  
Suite 12-2, Level 12  
Menara Sapura Kencana  
Petroleum  
Solaris Dutamas No. 1  
Jalan Dutamas 1  
50480 Kuala Lumpur, Malaysia  
Phone: +603-6209-0288  
Fax: +603-6205-3768

**International Head Office**

Miele & Cie. KG  
Carl-Miele-Straße 29  
33332 Gütersloh  
Germany

**South Africa**

Miele (Pty) Ltd  
63 Peter Place  
Bryanston 2194  
P.O. Box 69434  
Bryanston 2021  
Tel.: (011) 875 9000  
Fax: (011) 875 9035  
Internet: www.miele.co.za  
E-mail: info@miele.co.za

**Thailand**

Miele Appliances Ltd.  
BHIRAJ TOWER at EmQuartier  
43rd Floor Unit 4301-4303  
689 Sukhumvit Road  
North Klongton Sub-District  
Vadhana District  
Bangkok 10110, Thailand

CS 1018

en-SG, ZA

M.-Nr. 10 829 920 / 05