

Operating and installation instructions Induction cooktops



It is **essential** to read these operating and installation instructions before installing and using the appliance. This prevents both personal injury and damage to the appliance.

| | |
|--|-----------|
| Warning and Safety instructions | 6 |
| Caring for the environment | 18 |
| Overview | 19 |
| Your cooktop | 19 |
| Controls and display | 21 |
| Cooking zone data | 23 |
| Before using for the first time | 24 |
| Cleaning the cooktop for the first time | 24 |
| Switching on the cooktop for the first time | 24 |
| Miele@home | 25 |
| How it works | 28 |
| Cooking zones | 28 |
| Noises | 28 |
| Power management | 29 |
| Extractor | 30 |
| Cookware | 31 |
| Tips on saving energy | 33 |
| Power level range | 34 |
| Operation | 35 |
| Operating principles | 35 |
| Switching on the cooktop | 36 |
| Setting the power level | 36 |
| Switching off a cooking zone/the cooktop | 36 |
| Residual heat indicator | 36 |
| Setting the power level – extended power level range | 36 |
| PowerFlex cooking area | 37 |
| Auto heat-up | 38 |
| Deactivating Auto heat-up | 38 |
| Booster function | 39 |
| Keeping warm | 40 |
| Extractor | 41 |
| Timer | 43 |
| Minute minder | 43 |
| Auto switch-off | 44 |
| Using both timer functions at the same time | 44 |
| Additional functions | 45 |
| Stop & Go | 45 |
| Recall | 45 |
| Wipe protection | 46 |

Contents

| | |
|--|-----------|
| Demonstration mode..... | 46 |
| Displaying cooktop data..... | 46 |
| Safety features..... | 47 |
| System lock/Safety lock..... | 47 |
| Deactivating the system lock..... | 47 |
| Deactivating the safety lock..... | 47 |
| Safety switch-off..... | 48 |
| Overheating protection..... | 49 |
| Programming..... | 50 |
| Cleaning and care..... | 55 |
| Cover grille/Grease filter/Charcoal filter..... | 57 |
| Cleaning the extractor drip tray..... | 58 |
| Resetting the grease filter operating hours counter..... | 59 |
| Reactivating the charcoal filter..... | 59 |
| Resetting the charcoal filter operating hours counter..... | 59 |
| Problem solving guide..... | 60 |
| Messages in the display..... | 60 |
| Unexpected behaviour..... | 61 |
| Unsatisfactory results..... | 62 |
| General problems or technical faults..... | 62 |
| Optional accessories..... | 64 |
| Installation..... | 65 |
| Safety instructions for installation..... | 65 |
| Safety distances..... | 67 |
| Installation examples..... | 69 |
| Installation notes – surface-mounted..... | 70 |
| Installation dimensions – Surface-mounted..... | 71 |
| KMDA 7633 FR, KMDA 7634 FR..... | 71 |
| KMDA 7633 FL, KMDA 7634 FL..... | 72 |
| Worktop depth 600 mm..... | 73 |
| Worktop depth greater than 600 mm..... | 75 |
| Installation notes – flush-fit..... | 77 |
| Installation dimensions – Flush..... | 78 |
| KMDA 7633 FL, KMDA 7634 FL..... | 78 |
| Worktop depth 600 mm..... | 79 |
| Worktop depth greater than 600 mm..... | 81 |
| Changing extraction direction..... | 83 |
| Extraction to the right..... | 83 |
| Extraction to the left..... | 84 |
| Connection to window contact, if required..... | 86 |

Contents

| | |
|------------------------------------|-----------|
| Surface-mounted installation | 88 |
| Flush-fit installation..... | 89 |
| Exhaust ducting | 90 |
| Electrical connection | 91 |
| Service | 94 |
| Contact in case of fault..... | 94 |
| Data plate | 94 |
| Warranty | 94 |

Warning and Safety instructions

This cooktop complies with all relevant local and national safety requirements. However, inappropriate use can lead to personal injury and damage to property.

Read the operating and installation instructions carefully before using the cooktop. They contain important information on safety, installation, use and maintenance of the appliance. This prevents both personal injury and damage to the cooktop.

In accordance with standard IEC 60335-1, Miele expressly and strongly advises that you read and follow the instructions in “Installation”, as well as in the “Warning and Safety instructions”.

Miele cannot be held liable for injury or damage caused by non-compliance with these instructions.

Keep these instructions in a safe place and pass them on to any future owner.

Correct application

- ▶ This cooktop is designed for domestic use and for use in similar environments by guests in hotel or motel rooms, bed & breakfasts and other typical living quarters. This does not include common/shared facilities or commercial facilities within hotels, motels or bed & breakfasts.
- ▶ This cooktop is not suitable for outdoor use.
- ▶ It is intended only to cook food and keep it warm. Any other use is not supported by Miele and could be dangerous.
- ▶ This cooktop is not intended for use by people (including children) with reduced physical, sensory or mental capabilities or lack of experience and knowledge, unless they have been given supervision and instruction concerning its use by a person responsible for their safety. They may only use the cooktop unsupervised if they have been shown how to use it in a safe way. They must be able to recognise and understand the potential dangers of improper use.

Warning and Safety instructions

Safety with children

- ▶ Young children must not be allowed to use this appliance.
- ▶ Older children may only use the appliance if its operation has been clearly explained to them and they are able to use it safely. They must be aware of the potential dangers caused by incorrect operation.
- ▶ Cleaning may only be carried out by older children under the supervision of an adult.
- ▶ Please supervise children in the vicinity of the cooktop and do not let them play with it.
- ▶ The cooktop gets hot when in use and remains hot for a while after being switched off. Keep children well away from the cooktop until it has cooled down and there is no danger of burning.
- ▶ Danger of burning! Do not store anything which might arouse a child's interest in storage areas above or behind the cooktop. Otherwise children could be tempted to climb onto the cooktop with the risk of burning themselves.
- ▶ Danger of burning and scalding! Turn the handles of pots and pans on the cooktop to the side or the rear so that children cannot pull them down and burn themselves.
- ▶ Danger of suffocation! Whilst playing, children may become entangled in packaging material (such as plastic wrapping) or pull it over their head with the risk of suffocation. Keep packaging material away from children.
- ▶ Activate the system lock to ensure that children cannot switch on the cooktop inadvertently. Use the safety lock when the cooktop is in use to prevent children from altering the settings selected.

Technical safety

- ▶ Unauthorised installation, maintenance and repairs (including removal of any cover) can cause considerable danger for the user. Installation, maintenance and repairs must only be carried out by a Miele authorised technician.
- ▶ Damage to the cooktop can compromise your safety. Check the appliance for visible signs of damage. Do not use the cooktop if it is damaged.
- ▶ Temporary or permanent operation with a self-sufficient or non-mains synchronous energy supply system (e.g. isolated networks, back-up systems) is possible. A requirement for the operation is that the energy supply system complies with all current local and national requirements that apply to stand-alone, solar and/or battery systems. The protective measures provided in the installation and in this Miele product must also be assured in their function and operation in isolated operation or in non-mains synchronous operation, or replaced with equivalent measures in the installation.
- ▶ The electrical safety of this appliance can only be guaranteed when continuity is complete between it and an effective earthing system which complies with local and national safety regulations. It is most important that this basic safety requirement is present and tested regularly and, where there is any doubt, the household wiring system should be inspected by a qualified electrician.
- ▶ Before connecting the appliance to the mains electricity supply, ensure that the connection data on the data plate (voltage and frequency) matches the mains electricity supply. This data must correspond in order to avoid the risk of damage to the appliance.
- ▶ Do not connect the cooktop to the mains electricity supply by a multi-socket adapter or extension lead. These are a fire hazard and do not guarantee the required safety of the appliance.
- ▶ For safety reasons, this cooktop may only be used after it has been built in.
- ▶ This appliance must not be installed and operated in mobile installations (e.g. on a ship).
- ▶ Never open the casing of the cooktop.
Touching or tampering with electrical connections or components and mechanical parts is highly dangerous to the user and can cause operational faults.

Warning and Safety instructions

- ▶ The manufacturer's warranty may be invalidated if the appliance is not repaired by a Miele authorised service technician.
- ▶ Faulty components must only be replaced by genuine Miele spare parts. The manufacturer can only guarantee the safety of the appliance when Miele replacement parts are used.
- ▶ The cooktop is not intended for use with an external timer switch or a remote control system.
- ▶ The cooktop must be connected to the electricity supply by a qualified electrician (see “Installation – Electrical connection”).
- ▶ If the mains connection cable is damaged, it must be replaced with a special mains connection cable by a qualified and competent electrician in order to avoid a hazard (see “Installation - Electrical connection”).
- ▶ During installation, maintenance and repair work, the appliance must be disconnected from the mains electricity supply. It is only completely isolated from the electricity supply when:
 - the mains circuit breaker is switched off, or
 - it is switched off at the wall socket and the plug is withdrawn from the socket. Do not pull the mains connection cable but the mains plug to disconnect your appliance from the mains electricity supply.
- ▶ Danger of electric shock! If the ceramic surface is faulty, cracked, chipped or damaged in any way, do not use the cooktop and switch it off immediately. Disconnect the cooktop from the electricity supply. Contact Miele.
- ▶ If the cooktop is installed behind a furniture door, do not close the door while the cooktop is in operation. Heat and moisture can build up behind the closed door. This can result in damage to the cooktop, the housing unit and the floor. Do not close the door until the appliance has cooled down and the residual heat indicators have gone out.
- ▶ In areas which may be subject to infestation by cockroaches or other vermin, pay particular attention to keeping the appliance and its surroundings clean at all times. Any damage caused by cockroaches or other vermin will not be covered by the warranty.
- ▶ DO NOT MODIFY THIS APPLIANCE.

Warning and Safety instructions

Using at the same time as other heating appliances that depend on the air from the room

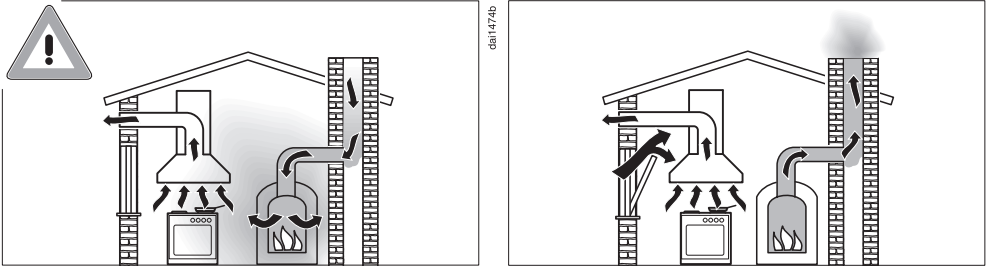

Danger of toxic fumes!

Great care should be taken when using the extractor in the same room or the same area of the house as another heating appliance that depends on the air from the room.

Such heating appliances draw in air from the room and duct exhaust gases out through a chimney or extraction ducting. They include gas, oil, wood and coal-fired boilers and heaters, continuous flow or other water heaters, gas cooktops and ovens.

The extractor draws in air from the kitchen and from neighbouring rooms. This applies to the following modes of operation:

- extraction mode,
- recirculation mode with a recirculation box installed outside the room.

If there is insufficient air, an underpressure will occur. The heating appliance may be starved of oxygen. This impairs combustion. Harmful gases could be drawn from the chimney or extraction ducting back into the room.

This could have potentially fatal consequences!

Warning and Safety instructions

In order to ensure safe operation and to prevent gases given off by the heating appliance from being drawn back into the room when the extractor and the heater are both operated simultaneously, an underpressure in the room of 4 Pa (0.04 mbar) is the maximum permissible.

Sufficient ventilation can be maintained by air inlets which cannot be blocked, e.g. in windows, doors and outside wall vents. The diameter of the inlet openings must enable sufficient ventilation. A ventilation brick alone is not generally sufficient to ensure safe ventilation.

The overall ventilation condition of the dwelling must be taken into account. If in any doubt, the advice of a competent builder or, for gas, a qualified gas fitter (registered with an official gas safety body in accordance with national safety regulations) must be sought.

If the extractor is being operated in recirculation mode, where the air is directed back into the room in which it is located, operating a heating appliance which depends on the room air at the same time is not hazardous.

Correct use

▶ The cooktop gets hot when in use and remains hot for a while after being switched off. There is a danger of burning until the residual heat indicators go out.

▶ Oil and fat can overheat and catch fire. Do not leave the cooktop unattended when cooking with oil and fat. If it does ignite, do not attempt to put the flames out with water.

Switch off the cooktop and use a suitable fire blanket, saucepan lid, damp towel or similar to smother the flames.

▶ The cooking process has to be supervised. A short term cooking process has to be supervised continuously.

▶ Open flames are a fire hazard!

Do not flambé food. When switched on, the extractor could draw flames into the filter. Kitchen grease deposits could ignite.

▶ Spray canisters, aerosols and other inflammable substances can ignite when heated. Therefore do not store such items or substances in a drawer under the cooktop. Cutlery inserts must be heat-resistant.

▶ Do not heat an empty pan.

▶ Do not heat up food in closed containers e.g. tins or sealed jars on the cooktop, as pressure can build up in the containers, causing them to explode.

▶ Do not cover the cooktop, e.g. with a cooktop cover, a cloth or protective foil. The material could catch fire, shatter or melt if the cooktop is switched on by mistake or if residual heat is still present.

▶ When the appliance is switched on either deliberately or by mistake, or when there is residual heat present, there is the risk of any metal items left on the cooktop heating up, with the danger of burning. Depending on the material, other items left on the cooktop could also melt or catch fire. Damp pan lids might adhere to the ceramic surface and be difficult to dislodge. Do not use the appliance as a resting place. Switch the cooking zones off after use and do not rely on the pan detector.

▶ You could burn yourself on the hot cooktop. Protect your hands with heat-resistant pot holders or oven gloves when handling hot pots and pans. Do not let them get wet or damp, as this causes heat to transfer through the material more quickly with the risk of scalding or burning yourself.

Warning and Safety instructions

- ▶ Hot cooking vapours during cooking can cause the extractor to get hot.
Do not touch the casing or the grease filters until the extractor has cooled down.
- ▶ When using an electrical appliance, e.g. a hand-held food mixer, near the cooktop, ensure that the cable of the electrical appliance cannot come into contact with the hot cooktop. The insulation on the cable could become damaged.
- ▶ Grains of salt, sugar and sand (e.g. from cleaning vegetables) can cause scratches if they get under pan bases. Make sure that the ceramic surface is clean before placing pans on it.
- ▶ Even a light object can cause damage in certain circumstances. Do not drop anything on the ceramic surface.
- ▶ Placing hot pans on the sensors and indicators could damage the electronics underneath. Do not place hot pans on the sensors or indicators.
- ▶ Do not allow solid or liquid sugar, or pieces of plastic or aluminium foil to get onto the cooktop when it is hot, as they can damage the ceramic surface when it cools down. If this should occur, switch off the appliance and scrape off all the sugar, plastic or aluminium residues whilst still hot, using a shielded scraper blade suitable for use on glass. Wear oven gloves when doing this. Allow the ceramic surface to cool down and then clean it with a suitable ceramic cooktop cleaning agent.
- ▶ Pans which boil dry can cause damage to the ceramic glass. Do not leave the cooktop unattended whilst it is being used.
- ▶ Only use pots and pans with smooth bases. Rough bases will scratch the ceramic glass.
- ▶ Lift pans into position on the cooktop. Sliding them into place can cause scuffs and scratches.
- ▶ Because induction heating works extremely quickly, the base of the pan could heat up to the temperature at which oil or fat self-ignites within a very short time. Do not leave the cooktop unattended whilst it is being used.
- ▶ Heat oil or fat for a maximum of one minute. Never use the Booster function to heat oil or fat.

Warning and Safety instructions

- ▶ For people fitted with a heart pacemaker: please note that the area immediately surrounding the cooktop is electromagnetically charged when it is switched on. It is very unlikely to affect a pacemaker. However, if in any doubt, consult the manufacturer of the pacemaker or your doctor.
- ▶ To prevent damage to items which are susceptible to electromagnetic fields, e.g. credit cards, digital storage devices, pocket calculators, etc., do not leave them in the immediate vicinity of the cooktop.
- ▶ Metal utensils stored in a drawer under the cooktop can become hot if the appliance is used intensively for a long time. Do not store any metal items or utensils in a drawer under the cooktop.
- ▶ The cooktop is fitted with a cooling fan. If a drawer is fitted directly underneath the cooktop, ensure that there is sufficient space between the drawer and its contents and the underside of the cooktop in order to ensure sufficient ventilation for the cooktop.
- ▶ If a drawer is fitted directly underneath the cooktop, do not store pointed or small items, paper, serviettes etc. in the drawer. They could get in through the ventilation slots or be sucked into the casing by the fan and damage the fan or impair cooling.
- ▶ Never use two pans on a cooking zone, extended zone or PowerFlex zone at the same time.
- ▶ If the cookware only partially covers a cooking zone or extended zone, the handle could become very hot. Always place cookware in the middle of a cooking zone or extended zone!
- ▶ Deposits of grease and dirt will prevent the extractor from working properly.
Do not use the extractor without the grease filters in place. Otherwise cooking vapours will not be cleaned.
- ▶ There is a risk of fire if cleaning is not carried out as described in these operating instructions.
- ▶ Do not cover the cover grille on the extractor when in use.
- ▶ Do not place hot pans on the cover grille of the extractor. This will impair the function of the extractor and may damage the cover grille.
- ▶ Liquids can damage the extractor if they get into it. Keep liquids away from the extractor.

Warning and Safety instructions

- ▶ Light objects can be drawn into the extractor and impair its operation. Do not place any light objects (e.g. paper towels) within close proximity of the extractor.
- ▶ If an induction adapter plate is used for cookware, the induction generator may be damaged or even destroyed. Do not use induction adapter plates.

Cleaning and care

- ▶ Do not use a steam cleaning appliance to clean this appliance. The steam could reach the electrical components and cause a short circuit.
- ▶ If the cooktop is built in over a pyrolytic oven, the cooktop should not be used whilst the pyrolytic process is being carried out, as this could trigger the overheating protection mechanism on the cooktop (see “Familiarising yourself with the appliance - Overheating protection”).

Accessories

- ▶ Use only genuine original Miele spare parts. If spare parts or accessories from other manufacturers are used, the warranty will be invalidated, and Miele cannot accept liability.
- ▶ Miele will guarantee to supply functional spare parts for a minimum of 10 years and up to 15 years following the discontinuation of your cooktop.

Caring for the environment

Disposal of the packing material

The transport and protective packaging has been selected from materials which are environmentally friendly for disposal, and can normally be recycled.

Recycling the packaging reduces the use of raw materials in the manufacturing process and also reduces the amount of waste in landfill sites.

Ensure that any plastic wrappings, bags etc. are disposed of safely and kept out of the reach of babies and young children. Danger of suffocation.

Disposing of your old appliance

Electrical and electronic appliances often contain valuable materials. They also contain specific materials, compounds and components, which were essential for their correct function and safety. These could be hazardous to human health and to the environment if disposed of with your domestic waste or if handled incorrectly. Please do not, therefore, dispose of your old appliance with your household waste.



Please dispose of it at your local community waste collection / recycling centre for electrical and electronic appliances. You are also responsible for deleting any personal data that may be stored on the appliance prior to disposal. Please ensure that your old appliance poses no risk to children while being stored prior to disposal.

Your cooktop

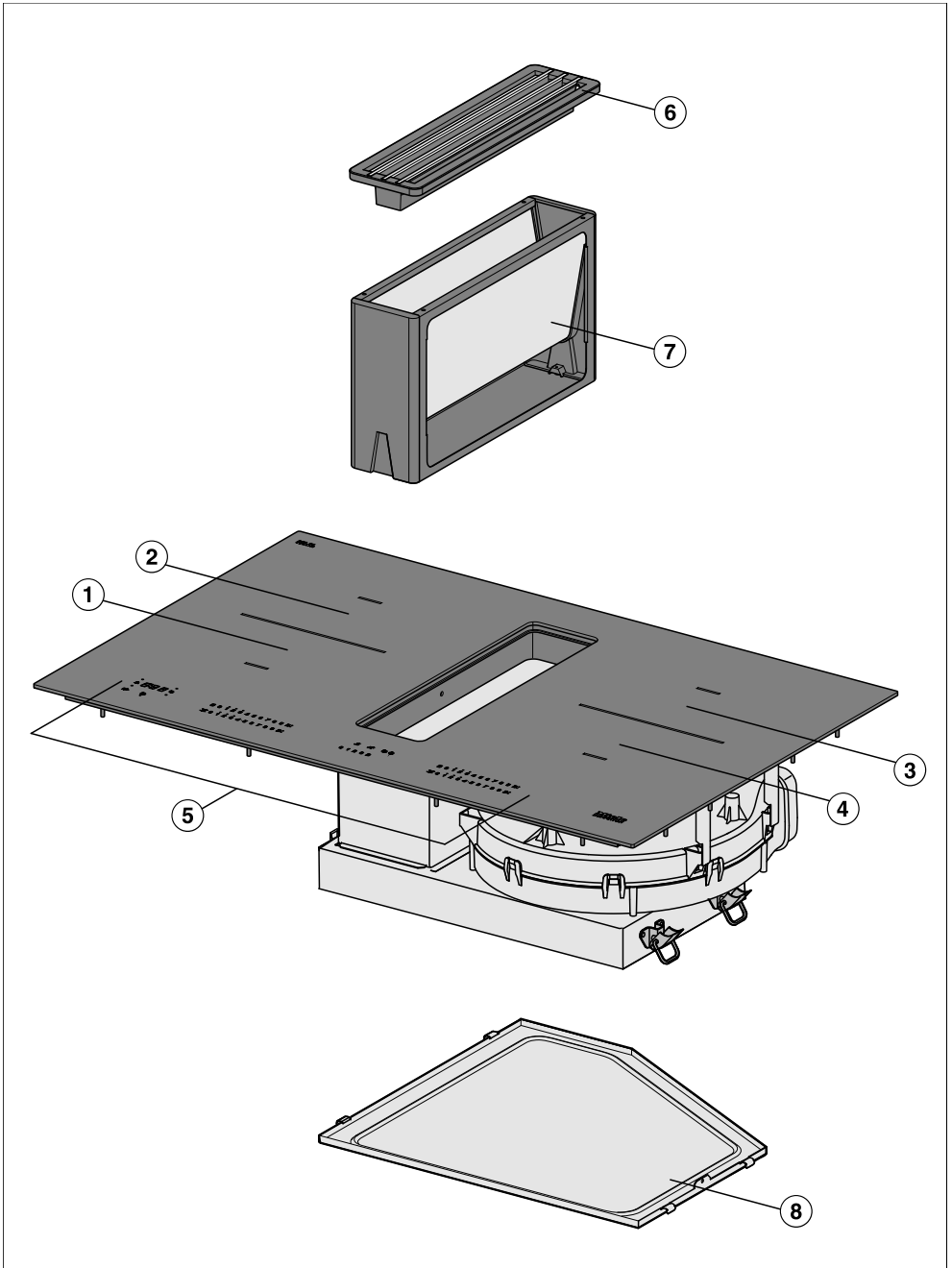

Overview

- ① PowerFlex cooking zone with TwinBooster
- ② PowerFlex cooking zone with TwinBooster can be combined with PowerFlex cooking zone ① to form PowerFlex cooking area
- ③ PowerFlex cooking zone with TwinBooster can be combined with PowerFlex cooking zone ④ to form PowerFlex cooking area
- ④ PowerFlex cooking zone with TwinBooster
- ⑤ Controls and indicators
- ⑥ Cover grille
- ⑦ Grease filter
- ⑧ Removable drip tray

Controls and display

Cooking zones/Timer

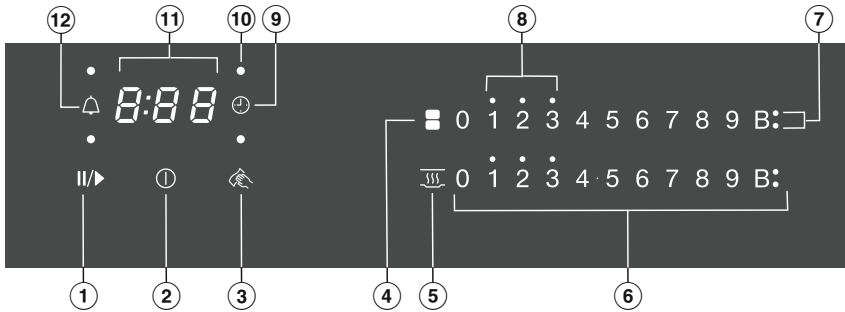

- ① Stop & Go sensor
For stopping/starting a cooking process in progress
- ② Cooktop On/Off sensor
- ③ Wipe protection sensor
For locking the sensors
- ④ PowerFlex cooking zones sensor
For manual connection/disconnection of PowerFlex cooking zones
- ⑤ Keeping warm sensor
For activating/deactivating the Keeping warm function
- ⑥ Numerical display sensors
– For setting the power level
– For setting the times
- ⑦ Booster display
Booster function is activated
- ⑧ Residual heat indicators
- ⑨ Automatic switch-off sensor
Switches the cooking zones off automatically
- ⑩ Cooking zone allocation auto switch-off indicator light
Auto switch-off for the cooking zone is activated
- ⑪ Timer display

| | |
|---------|--------------------------------------|
| 0:00 to | Duration |
| 9:59 | |
| LOC | System lock/Safety lock is activated |
| dE | Demo mode is activated |
- ⑫ Minute minder sensor

Overview

Extractor

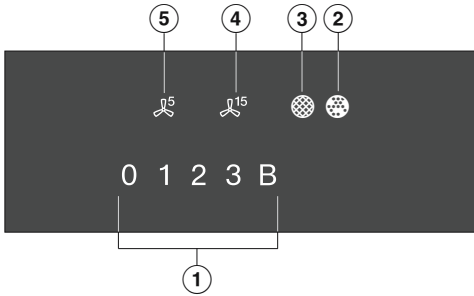

- ① Numerical display sensors
For setting a power level
- ② Charcoal filter indicator
The charcoal filter must be cleaned
- ③ Grease filter indicator
The grease filter must be cleaned
- ④ Sensor for the 15 minute run-on option
- ⑤ Sensor for the 5 minute run-on option

Cooking zone data

| Cooking zone | Size in cm | | Max. rating in watts for 230 V ³ | | Connected cooking zone ⁴ |
|----------------|----------------|--|--|----------------------|-------------------------------------|
| | ∅ ¹ |  ² | | | |
| ① | 15–23 | 19x23 | Normal TwinBooster, level 1 TwinBooster, level 2 | 2100 3000 3650 | ③ |
| ② | 15–23 | 19x23 | Normal TwinBooster, level 1 TwinBooster, level 2 | 2100 3000 3650 | ④ |
| ③ | 15–23 | 19x23 | Normal TwinBooster, level 1 TwinBooster, level 2 | 2100 3000 3650 | ① |
| ④ | 15–23 | 19x23 | Normal TwinBooster, level 1 TwinBooster, level 2 | 2100 3000 3650 | ② |
| ① + ② ③ + ④ | 22–23 | 23x39 | Normal TwinBooster, level 1 TwinBooster, level 2 | 3400 4800 7300 | - |
| | | | Total | 7300 | |

¹ Pans with any base diameter within the given range may be used.

² The given range corresponds to the maximum base surface of the pans that may be used.

³ ** The wattage quoted may vary depending on the size and material of the cookware used.

⁴ The cooking zone is electrically connected to this cooking zone to increase the power output (see "How it works - Power management").

Before using for the first time

- Please stick the extra data plate for the appliance supplied with this documentation in the space provided in the “Service” section of this booklet. Alternatively, the additional label can be stuck near the appliance if the appliance markings are not visible after installation.
- Remove any protective wrapping and stickers (except the data plate).

Cleaning the cooktop for the first time

- Before using for the first time, clean the cooktop with a damp cloth only and then wipe dry.

Switching on the cooktop for the first time

The metal components have a protective coating which may give off a slight smell when heated up for the first time. The induction coils may also give off a slight smell for the first few hours of operation. This smell will be less noticeable with each subsequent use before dissipating completely.

The smell and any vapours given off do not indicate a faulty connection or appliance and they are not hazardous to health.

Please note that the heating up time on induction cooktops is significantly shorter than on conventional cooktops.

Before using for the first time

Miele@home

Prerequisite: Home Wi-Fi network

Your cooktop is equipped with an integrated Wi-Fi module. The cooktop can be connected to the household Wi-Fi network.

Make sure there is sufficient signal strength for your Wi-Fi network where the cooktop is installed.

There are a number of ways of connecting your cooktop to your Wi-Fi network.

The cooktop requires max. 2 W in networked standby.

Availability of the Wi-Fi connection

The Wi-Fi connection shares a frequency range with other appliances (including microwave ovens and remote control toys). This may result in sporadic or even complete connection failures. Therefore, a constant availability of featured functions cannot be guaranteed.

Miele@home availability

The ability to use the Miele App depends on the availability of the Miele@home service in your country.

The Miele@home service is not available in every country.

For information about availability, please visit www.miele.com.

Miele App

You can download the Miele App from the Apple App Store® or the Google Play Store™ free of charge (only functional in selected countries).



After installing the Miele App on a mobile device, you can do the following:

- Call up information on the operating status of your cooktop
- Call up information on the programme sequence of your cooktop
- Set up a Miele@home network with other Wi-Fi enabled Miele appliances

Before using for the first time

Setting up Miele@home

Connecting via the App

The Miele App can be used to connect to your network.

- Install the Miele App on your mobile device.

To log in you will need:

1. Your Wi-Fi network password.
2. The password of your cooktop.

The password for your cooktop consists of the last nine digits of the serial number. This can be found on the appliance's data plate.

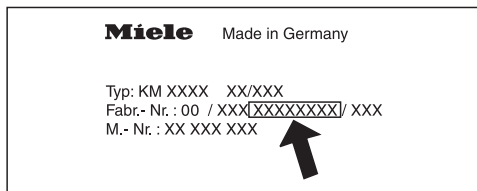

- Switch the cooktop on.
- Start the Miele App.
- Touch the 0 sensor on any of the numerical keybanks.
- Touch the 0 and 5 sensors at the same time for 6 seconds.

The seconds can be seen counting down in the timer display. When this time has elapsed, the code **C:01** is displayed in the timer display for 10 seconds.

You now have 10 minutes to configure the Wi-Fi.

- Follow the instructions in the App.

Connecting via WPS

You must have a WPS (Wi-Fi protected setup) compatible router.

- Switch the cooktop on.
- Touch the 0 sensor on any of the numerical keybanks.
- Touch the 0 and 6 sensors at the same time for 6 seconds.

The seconds can be seen counting down in the timer display. When this time has elapsed, a progress light will appear during the connection attempt (for max. 120 seconds).

The WPS login is only active during these 120 seconds.

- Activate the WPS function on your router.

If the connection was successful, the code **C:02** appears in the timer display. If the connection could not be established, the timer display will show the code **C:01**. You have probably not activated WPS on your router quickly enough. Repeat the steps above.

Useful tip: If your Wi-Fi router does not support WPS, please connect via the Miele App.

Canceling the process

- Touch any sensor.

Resetting settings

It is not necessary to reset the cooktop when you replace the router.

- Switch the cooktop on.
- Touch the 0 sensor on the numerical display.
- Touch the 0 and 9 sensors at the same time for 6 seconds.

The seconds can be seen counting down in the timer display. When this time has elapsed, the code **C:00** is displayed in the timer display for 10 seconds.

Reset the settings if you are disposing of your cooktop, selling it or putting a used cooktop into operation. This is the only way to ensure that all personal data has been removed and, in the case of the latter situation, the previous owner will no longer be able to access the cooktop.

How it works

Cooking zones

An induction coil is located under each cooking zone. The coil creates a magnetic field that reacts directly with the base of the pan and heats it up. The cooking zone itself is heated up indirectly by the heat given off by the pan.

An induction cooking zone only works when a pan with a magnetic base is placed on it (see "Cookware"). Induction automatically recognises the size of the pan.

The pan base material and the position of the pan on the cooking zone affect the power of the induction coils. This can affect the cooking behaviour.



Risk of burning due to hot items!

When the cooktop is switched on, either deliberately or by mistake, or when there is residual heat present, there is a risk of metal items placed on the cooktop heating up.

Do not use the cooktop as a resting place for anything else.

After use, switch the cooktop off with the  sensor control.

Noises

When using an induction cooking zone, the following noises can occur in the pan, depending on what it is made of and how it has been constructed.

On the higher power settings, the appliance might buzz. This will decrease or cease altogether when the power setting is reduced.

If the pan base is made of layers of different materials (e.g. in a sandwiched base), it might emit a cracking sound.

Whistling might occur if linked zones (see "Operation - Booster") are being used at the same time, and the pans also have bases made of layers of different materials.

You might hear a clicking sound from the electronic switches, especially on lower power settings.

You might hear a whirring sound when the cooling fan switches on. It switches on to protect the electronics when the cooktop is being used intensively. The fan may continue to run after the cooktop has been switched off.

Power management

Total power

The cooktop has a maximum total permitted power consumption which cannot be exceeded for safety reasons. You can reduce the maximum total permitted power consumption (see “Adjusting settings”).

The higher the total permitted power consumption of the cooktop, the more power levels/functions that can be used simultaneously on all cooking zones.

If the set power levels/functions require more power than can be made available by the total permitted power output, the cooktop will distribute the possible power across the cooking zones.

Power distribution

Cooking zones can be linked together in pairs on the cooktop. This allows power to be transferred from one cooking zone (A) to another zone (B). This transfer reduces the power on cooking zone (A).

Example: the Booster for cooking zone (B) is activated.

The cooking zone (B) which requires power is determined by the most recently selected setting on the cooktop.

The values for the maximum total permitted power consumption and which cooking zones are linked together can be found in “Overview – Cooking zone data”.

You can reduce the maximum total permitted power consumption (see “Programming”).

Effects of distributing the power

When a cooking zone gives power to another zone, it can have the following effects on the power of the first zone:

- The power level is reduced.
- Auto heat-up will be deactivated. Cooking continues at the set level. If the power is not sufficient, the power level will be reduced again.
- The Booster function is deactivated.
- The cooking zone is switched off.

If the most recently set power level is reduced or the Booster function is switched off, the power level for the linked cooking zone can be increased again.

Useful tip: If you want to cook large quantities of food on a cooking zone, switch the other cooking zones to lower power levels.

How it works

Extractor

The extracted air drawn into the extractor must not be routed into the base unit. This will damage the cabinet.



Air extraction mode

The air drawn in is cleaned by the grease filter and directed outside through a ventilation gap.

Recirculation mode

The air is drawn in and cleaned by the grease filter. The air is then directed into the recirculation box where it is also cleaned by a charcoal filter. The cleaned air is then recirculated back into the kitchen. The necessary accessories are available from Miele. The necessary accessories are available from Miele.

Operating hours counter

The number of hours that the extractor has been used for is stored in memory. When the grease filter symbol  or the charcoal filter symbol  lights up, the operating hours counters are signalling that the filters need to be cleaned or replaced. Further information about cleaning and replacing the filters and resetting the operating hours counters can be found under "Cleaning and care".

The operating and installation instructions supplied with the recirculation box state that the operating hours counter for the charcoal filter needs to be activated. This is not necessary here.

The charcoal filter symbol  also appears when the appliance is operated using extraction mode.

Suitable pans

- stainless steel pans with a base that can be magnetised
- enamelled steel pans
- cast iron pans

Please be aware that the properties of the pan base can affect the evenness with which the food heats up (e.g. when making pancakes). The base of the pan must be able to distribute the heat evenly. Cookware with a base made of multi-layered material (sandwich or encapsulated base) is suitable.

Unsuitable pans

- stainless steel pans with a base which cannot be magnetised
- aluminium or copper pans
- glass, ceramic or earthenware pots and pans

Testing cookware

To test whether a pot or pan is suitable for use on an induction cooktop, hold a magnet to the base of the pan in several different places. If the magnet sticks, the pan is generally suitable.

No pan/Unsuitable pan display

The set power level flashes in the numerical keybank for the cooking zone

- if the cooking zone is switched on without a pan in place, or if the pan is unsuitable (non-magnetic base).
- the diameter of the base of the pan is too small.
- the pan is taken off the cooking zone while it is switched on.

If no pan or an unsuitable pan is placed on the cooking zone, the cooking zone will switch off automatically after 3 minutes.

Using a cooking zone

- Place a suitable item of cookware on the cooking zone within 3 minutes.

The flashing power level goes out. The cooking process is continued with the previously selected settings.

- If you are using a different item of cookware and/or food, modify the settings.

Not using a cooking zone

- Switch the cooking zone off.

Cookware

Useful tips

- To make optimum use of the cooking zones, choose pans with a suitable base diameter (see "Overview - Cooking zone data"). If the pan is too small, it will not be recognised.
 - Position the cookware as centrally as possible on the relevant cooking zone/ cooking area.
 - Use only pots and pans with smooth bases. Rough bases can scratch the ceramic glass.
 - Always lift the cookware to move it. This will help prevent scratching. If any scratches do appear as a result of cookware being pushed around, this will not affect the function of the cooktop. These scratches are normal signs of use and are not grounds for making a complaint.
- Please note that the maximum diameter quoted by manufacturers often refers to the diameter of the top rim of the pot or pan. The diameter of the base (generally smaller) is more important.

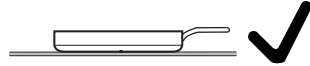

- Cook in covered pots and pans if possible. This prevents heat escaping unnecessarily.
- Select a smaller pan when cooking small quantities. A smaller pan uses less energy than a larger pan with very little in it.
- Cook with as little water as possible.
- Once food has come to the boil or the pan is hot for frying, reduce the heat to a lower power level.
- Use a pressure cooker to reduce the cooking duration.
- It is important to ensure that the kitchen is well ventilated during operation. In extraction mode if there is insufficient airflow, the extractor cannot operate efficiently and this causes increased operating noise levels.
- Always cook with the lowest possible cooking setting. This produces fewer cooking vapours, so you can use a lower extractor power level and therefore benefit from reduced energy consumption.
- Check the power level on the extractor. A low power level is usually sufficient. Only use the Booster setting when necessary.
- When a large volume of cooking vapours are being produced, switch to a high power level in good time. This is more efficient than operating the extractor for longer to try to capture cooking vapours which have already been distributed throughout the kitchen.
- Switch the extractor off after cooking.
- Clean or replace the filters at regular intervals. Heavily soiled filters reduce performance, increase the risk of fire and are unhygienic.

Power level range

The cooktop is programmed with 9 power levels at the factory. If you wish to fine-tune a setting, you can extend the power level range to 17 power levels (see “Programming”).

| | Settings | |
|---|----------------------------------|-------------------------------------|
| | Default setting (9 power levels) | Extended settings (17 power levels) |
| Melting butter Dissolving gelatine Melting chocolate | 1–2 | 1–2. |
| Making milk puddings | 2 | 2–2. |
| Warming small quantities of liquid Cooking rice | 3 | 3–3. |
| Defrosting frozen vegetables (blocks) | 3 | 2.–3 |
| Making porridge | 3 | 2.–3. |
| Warming liquid and semi-solid foods Making omelettes or lightly fried eggs Steaming fruit | 4 | 4–4. |
| Cooking pasta/dumplings | 4 | 4–5. |
| Steaming vegetables and fish | 5 | 5 |
| Defrosting and reheating frozen food | 5 | 5–5. |
| Gently frying eggs (without overheating the fat) | 6 | 5.–6. |
| Bringing large quantities of food to the boil, e.g. casseroles Thickening custard and sauces, e.g. hollandaise | 6–7 | 6.–7 |
| Gentle braising (without overheating the fat) of fish, schnitzel and sausages | 6–7 | 6.–7. |
| Frying pancakes, potato fritters etc. | 7 | 6.–7 |
| Braising for stews | 8 | 8–8. |
| Boiling large quantities of water Bringing to the boil | 9 | 9 |

These settings should only be taken as a guide. The power of the induction coils will vary depending on the size and material of the pan. For this reason, it is possible that the settings will need to be adjusted slightly to suit your pans. As you use the cooktop, you will get to know which settings suit your pans best. When using new pans that you are not familiar with, set the power level below the one specified.

Operating principles

This ceramic cooktop is equipped with electronic sensor controls which react to finger contact. For safety reasons, when switching the appliance on, the On/Off ① sensor needs to be touched for a little longer than the other sensors. Each time you touch a sensor, an acoustic signal sounds.

Only the printed On/Off ① symbol is visible when the cooktop is switched off. More sensor controls light up when the cooktop is switched on.

 Malfunction due to dirty and/or covered sensors.

If the sensors are dirty or covered, this could cause them to fail to react, to activate a function inadvertently or even to switch the appliance off automatically (see "Safety features – Safety switch-off"). Placing hot pans on the sensor controls/indicators can damage the electronic unit underneath.

Keep the sensors and indicators clean.

Do not place anything over the sensors or indicators.

Do not place hot pans over the sensors or indicators.

Operation

 Risk of fire due to overheated food.

Unattended food can overheat and ignite.

Do not leave the cooktop unattended whilst it is being used.

Please note that the heating-up time on induction cooktops is much shorter than on conventional cooktops.

Switching on the cooktop

- Touch the ① sensor.

Further sensor controls will light up.

If no further entry is made, the cooktop will switch itself off after a few seconds for safety reasons.

Setting the power level

Permanent pan recognition is activated as standard (see "Programming").

When the cooktop is switched on and you place an item of cookware on one of the cooking zones, all the sensors for the numerical display will light up.

- Place a pan on the cooking zone you want to use.
- Touch the appropriate sensor for the power level you want on the relevant numerical display.

Switching off a cooking zone/ the cooktop

- To switch off a cooking zone, touch the 0 sensor on the numerical display for that cooking zone.
- To switch off the cooktop and all the cooking zones, touch the ① sensor.

Residual heat indicator

If a cooking zone is still hot, the residual heat indicator will light up after the zone has been switched off. Depending on the temperature, a dot will appear above power levels 1, 2 and 3.

The dots of the residual heat indicator will go out one after another as the cooking zone cools down.

 Risk of burning on hot cooking zones!

The cooking zones will be hot after use.

Do not touch the cooking zones while the residual heat indicators are on.

Setting the power level – extended power level range

- Touch the numerical display between the sensors.

The sensors in front of and after the interim level will light up brighter than the other sensors.

Example:

If you have set power level 7, the numbers 7 and 8 will be brighter than the other numbers.

PowerFlex cooking area

The PowerFlex cooking zones combine automatically to form a PowerFlex cooking area when you place a sufficiently large pot or pan on them (see "Overview - Cooktop"). Settings for the linked cooking area are controlled by the numerical keybank of the front or left PowerFlex zone (depending on model). The PowerFlex cooking area can also be switched on and off manually:

- Touch the  sensor.

Positioning cookware

Refer to the cooking zone data for your cooktop model for information about cookware sizes and the corresponding positions (see "Overview – Cooking zone data").

PowerFlex cooking zone

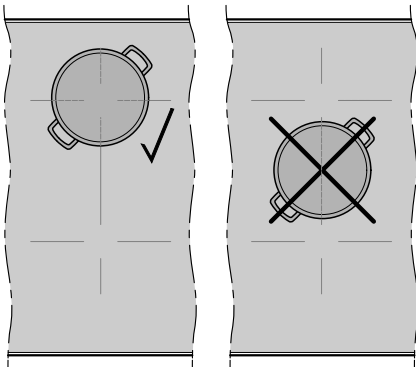

PowerFlex cooking area (pot)

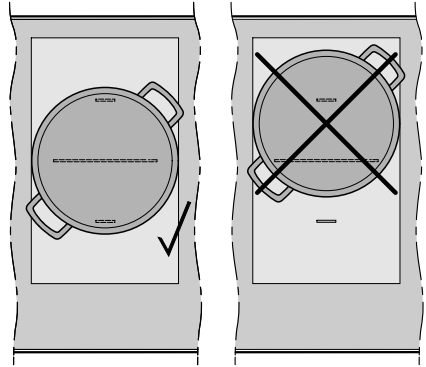

PowerFlex cooking area (oven dishes)

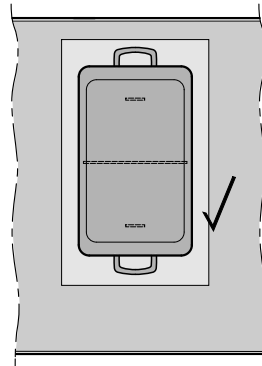

Operation

Auto heat-up

When Auto heat-up has been activated, the highest setting automatically switches on and then switches to the continued cooking setting which you have previously selected. The heat-up time depends on which continued cooking setting has been chosen (see chart).

Activating Auto heat-up

- Touch the sensor for the continued cooking setting you want until a tone sounds and the sensor starts to pulsate.

During the heat-up time (see chart), the continued cooking setting selected will pulsate.

With extended power levels (see "Programming") and a selected interim power level, the sensors for the power levels in front of and after the interim power level will pulsate.

Changing the continued cooking setting while heating up deactivates Auto heat-up.

Deactivating Auto heat-up

- Touch the sensor for the continued cooking setting.
- or
- Set a different power level.

| Continued cooking setting* | Heat-up time [min:sec] |
|----------------------------|------------------------|
| 1 | approx. 00:15 |
| 1. | approx. 00:15 |
| 2 | approx. 00:15 |
| 2. | approx. 00:15 |
| 3 | approx. 00:25 |
| 3. | approx. 00:25 |
| 4 | approx. 00:50 |
| 4. | approx. 00:50 |
| 5 | approx. 2:00 |
| 5. | approx. 5:50 |
| 6 | approx. 5:50 |
| 6. | approx. 2:50 |
| 7 | approx. 2:50 |
| 7. | approx. 2:50 |
| 8 | approx. 2:50 |
| 8. | approx. 2:50 |
| 9 | — |

* The continued cooking settings with a dot after the number are only available if the power level range has been extended (see "Programming").

Booster function

When the Booster function is activated, the power is boosted so that large quantities can be heated up quickly, e.g. when boiling water for cooking pasta. The boost in power is active for a maximum of 15 minutes.

When the Booster feature is activated, the settings for the linked cooking zone may be changed.

You can use the Booster function:

- on any cooking zone on either side
or
- on both cooking zones on one side
or
- on a PowerFlex cooking area

If the Booster function is switched on when

- no power level has been selected, the power level will revert automatically to power level 9 at the end of the Booster time or if the Booster function is switched off before this.
- a power level has been selected, the power level will revert automatically to the power level selected at the end of the Booster time or if the Booster function is switched off before this.

Activating the TwinBooster feature

Level 1

- Place a pan on the cooking zone you want to use.
- Select a power level if necessary.
- Touch the **B** sensor.

The indicator light ● for TwinBooster level 1 lights up.

Level 2

- Place a pan on the cooking zone you want to use.
- Select a power level if necessary.
- Touch the **B** sensor twice.

The indicator light ● for TwinBooster level 2 lights up.

Deactivating the Booster/TwinBooster function

- Touch the **B** sensor control repeatedly until the indicator lights go out.
- or
- Set a different power level.

Operation

Keeping warm

This function is for keeping food warm which has just been cooked and is still hot. It is not for reheating food that has gone cold.

The maximum duration for keeping food warm is 2 hours.

- Only keep food warm in suitable cookware (pots/pans). Cover the pot/pan with a lid.
- Stir firm or viscous food (mashed potatoes, stew) occasionally.
- Nutrients are lost when food is cooked, and continue to diminish when food is kept warm. The longer food is kept warm for, the greater the loss of nutrients. Try to keep food warm for as short a time as possible.

Activating/Deactivating the keeping warm function

- Touch the  sensor for the cooking zone you wish to use.

Keeping warm temperatures

A keeping warm temperature of 85 °C is set as standard. You can change the keeping warm temperature (see “Programming”).

| Use | Temperature °C |
|---|----------------|
| Melting chocolate | 50–55 |
| Keeping solid food and thick liquids warm | 65–75 |
| Keeping clear soups warm | 80–90 |

The cooking result can be negatively affected if food is kept warm at excessively high temperatures. Food can change colour and even spoil.

Extractor

The extractor will switch itself on automatically if there is a pan on a cooking zone and a power level has been set for that zone (Con@ctivity). The power level on the extractor is set to suit the power level on the cooktop.

You can deactivate Con@ctivity temporarily.

The power level on the extractor can be manually altered at any time. For light to heavy cooking vapours, select from power levels **1** to **3**. For short periods of strong vapours and cooking odours, e.g. whilst searing meat, select the **B** Booster setting.

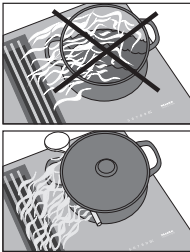

Useful tip: To help release vapours effectively with pans over 15 cm high, place a wooden spoon between the lid and the pan.

Setting the power level / Switching off

- To switch the fan on and set a power level, touch the appropriate sensor for the power level you want.
- To switch the fan off, touch the **0** sensor.

If the extractor is not switched off, it will switch itself off automatically 12 hours after the last sensor is touched.

Deactivating Con@ctivity

The extractor has switched on automatically.

- Touch the **0** control to deactivate Con@ctivity.
- Set the power level you want.

Con@ctivity is activated again when you switch the cooktop off and back on again.



Booster





The maximum duration for the Booster is 10 minutes.

- To switch the Booster off early, set a different power level.

Operation

Run-on time

It is advisable to run the fan for a few minutes after cooking has finished. This helps to neutralise any lingering vapours and odours in the air. The following two options are available:  (5 minutes) and  (15 minutes). The run-on duration will be carried out using the power level set during activation. You can change the power level during the run-on period.

- Touch the  or  sensor to activate the run-on period.
- Touch the ,  or  sensor to deactivate the run-on period.

If you switch the cooktop off with the  sensor, the run-on period will continue through to the end.

The cooktop has to be switched on if you wish to use the timer.

The timer can be used for the following 2 functions:

- For setting the minute minder
- For automatically switching a cooking zone off

You can use the functions simultaneously.

A duration of between 1 minute (0:01) and 9 hours 59 minutes (9:59) can be set.

Durations of up to 59 minutes are shown in minutes (00:59) and durations of more than 60 minutes are shown in hours and minutes. Durations are entered in the order of hours, followed by minutes in tens and then units.

Example:

59 minutes = 00:59 hours,

Enter: 5-9

80 minutes = 1:20 hours,

Enter: 1-2-0

After the first number has been entered, the timer display will light up constantly. After the second number has been entered, the first number will move to the left. After the third number has been entered, the first and second numbers will move to the left.

Minute minder

The minute minder is set using the numerical display for the left or front left cooking zone (depending on model).

Setting the minute minder

- Touch the  sensor.

The timer display flashes.

- Set the required time.

Touch the  sensor or wait 10 seconds to start the minute minder.

Changing the time set for the minute minder

- Touch the  sensor.

The timer display flashes.

- Set the required time.

Cancelling the minute minder

- Touch the  sensor.

- Touch  on the numerical display.

Timer

Auto switch-off

You can set a time after which the cooking zone will switch off automatically. This function can be used on all zones at the same time.

If the time programmed is longer than the maximum operational time allowed, the safety switch-off will switch off the cooking zone after the maximum permitted safety time has elapsed (see "Safety features - Safety switch-off").

The switch-off time is set on the numerical display for each cooking zone you want to switch off automatically.

Setting the switch-off time

- Select a power level for the cooking zone you wish to use.
- Touch the ⌚ sensor.

The timer display flashes.

- Set the required time.

Touch the ⌚ sensor or wait 10 seconds to start the switch-off time.

The cooking zone allocation auto switch-off indicator light pulsates.

- To set a switch-off time for another cooking zone, follow the same steps as described above.

If more than one switch-off time is programmed, the shortest time left will be displayed, and the corresponding indicator light will pulsate. The other indicator lights will light up constantly.

- To display the remaining times running in the background, touch the ⌚ sensor repeatedly until the indicator light for the desired cooking zone pulses.

Changing the switch-off time

- Touch the ⌚ sensor repeatedly until the indicator light for the cooking zone you require pulsates.

The timer display flashes.

- Set the required time.

Deleting the switch-off time

- Touch the ⌚ sensor repeatedly until the indicator light for the cooking zone you require pulsates.

The timer display flashes.

- Touch the \square sensor on the numerical display.

Using both timer functions at the same time

If you use both functions simultaneously, the shortest time is always displayed. The \triangle sensor (minute minder) or the indicator light of the cooking zone with the shortest time pulsates.

- Touch the \triangle or ⌚ sensor if you want to show the times left counting down in the background.
- If a switch-off time has been programmed for several cooking zones, touch the ⌚ sensor repeatedly until the indicator for the required cooking zone pulsates.

Stop & Go

When Stop & Go is activated, the power of all cooking zones in use is reduced to power level 1. The power level of the extractor is not reduced. Depending on the power level set for the cooktop, the power level of the extractor may even increase.

The power levels set for the cooking zones and the timer settings cannot be changed, the cooktop can only be switched off. The minute minder, switch-off, Booster and Auto heat-up times continue to run.

When Stop & Go is deactivated, the cooking zones will operate at the power level previously selected.

If the function is not deactivated within 1 hour, the cooktop will switch off.

Activating/Deactivating

- Touch the II/▶ sensor.

Use this function if there is a danger of food boiling over.

Recall

If the cooktop is switched off inadvertently during operation, this function can be used to reset all settings. For this to work, the cooktop must be switched on again within 10 seconds of being switched off.

- Switch the cooktop on again.

The previously set power levels will flash.

- Press one of the flashing power level indicators immediately.

All the cooking zones and the timer will continue to operate using the settings selected previously.

Additional functions

Wipe protection

The cooktop sensors can be locked for 20 seconds in order, for example, to remove soiling. The  sensor control is not locked.

Activating

- Touch the  sensor.

The time counts down in the timer display.

Deactivating

- Touch the  sensor control until the timer display goes out.

Demonstration mode

This function enables the cooktop to be demonstrated in showrooms without heating up.

Activating/Deactivating

- Switch the cooktop on.
- Touch the 0 sensor on the numerical display.
- Then touch the 0 and 2 sensors at the same time for 6 seconds.

In the timer display, *dE* flashes alternately with *Dn* (demonstration mode activated) or *OFF* (demonstration mode deactivated) for a few seconds.

Displaying cooktop data

The model designation and software version can be displayed. There must not be any pots or pans on the cooktop.

Model number

- Switch the cooktop on.
- Touch the 0 sensor on the numerical display.
- Then touch the 0 and 4 sensors at the same time.

The timer display shows 2 numbers flashing alternately:

Example: *12* flashing alternately with *34*
= KM 1234

Software version

- Switch the cooktop on.
- Touch the 0 sensor on the numerical display.
- Then touch the 0 and 3 sensors at the same time.

Numbers appear in the timer display:

Example: *2:00* = Software version 2.00

System lock/Safety lock

The safety lock is deactivated if there is a break in the mains electricity supply.

Your cooktop is equipped with a system lock and a safety lock to prevent the cooktop, cooking zones and extractor being switched on inadvertently or any settings being altered.

The **system lock** is activated when the cooktop is switched off. If the system lock is activated, the cooktop cannot be switched on and the timer cannot be used. A set minute minder time continues to count down. The cooktop is programmed so that the system lock must be activated manually. It can be programmed so that the system lock activates automatically 5 minutes after the cooktop has been switched off (see "Programming").

The **safety lock** is activated while the cooktop is switched on. When the safety lock is activated, the cooktop can be operated only under certain conditions:

- The cooking zones, the extractor and the cooktop can only be switched off.
- A set minute minder time can be modified.

If an unavailable sensor is touched whilst the system lock or safety lock is activated, *LDC* will appear in the timer display for a few seconds and a tone will sound.

Activating the system lock

- Touch the ① sensor for 6 seconds.

The seconds can be seen counting down in the timer display. When this time has elapsed, *LDC* will appear in the timer display. The system lock is switched on.

Deactivating the system lock

- Touch the ① sensor for 6 seconds.

LDC will appear briefly in the timer display and then the seconds will count down. The system lock is deactivated once the time has elapsed.

Activating the safety lock

- Touch and hold the ⊕ and II/▶ sensors at the same time for 6 seconds.

The seconds can be seen counting down in the timer display. When this time has elapsed *LDC* will appear in the timer display. The safety lock is activated.

Deactivating the safety lock



- Touch and hold the ⊕ and II/▶ sensors at the same time for 6 seconds.

LDC will appear briefly in the timer display and then the seconds will count down. The safety lock is deactivated once the time has elapsed.

Safety features

Safety switch-off

Sensors are covered

Your cooktop will switch off automatically if one or several of the sensors remain covered for longer than 10 seconds, for example, by finger contact, food boiling over or by an object such as an oven glove or tea towel.  flashes briefly above the  sensor control and a tone will sound.  will go out once you have removed the object and/or cleaned the cooktop and the cooktop will be ready to use again.

Excessive operating time

The safety switch-off mechanism is triggered automatically if a cooking zone is heated for an unusually long period of time. This time depends on the power level selected. If it has been exceeded, the cooking zone switches off and the residual heat indicator for that zone appears. If you switch the cooking zone on and off again, it is ready for operation again.

The cooktop is programmed to safety setting 0 at the factory. If required, you can set a higher safety setting with a shorter maximum operating time (see chart).

| Power level* | Maximum operating time [h:min] | | |
|--------------|--------------------------------|-------|-------|
| | Safety setting | | |
| | 0** | 1 | 2 |
| 1 | 10:00 | 8:00 | 5:00 |
| 1. | 10:00 | 7:00 | 4:00 |
| 2/2. | 5:00 | 4:00 | 3:00 |
| 3/3. | 5:00 | 3:30 | 2:00 |
| 4/4. | 4:00 | 2:00 | 1:30 |
| 5/5. | 4:00 | 1:30 | 1:00 |
| 6/6. | 4:00 | 1:00 | 00:30 |
| 7/7. | 4:00 | 00:42 | 00:24 |
| 8 | 4:00 | 00:30 | 00:20 |
| 8. | 4:00 | 00:30 | 00:18 |
| 9 | 1:00 | 00:24 | 00:10 |

* The power levels with a dot after the number are only available if the power level range has been extended (see "Power level range").

** Factory default setting

Overheating protection

All the induction coils and cooling elements for the electronics are fitted with an overheating protection mechanism. Before the induction coils and/or cooling elements get too hot, the overheating protection mechanism activates in one of the following ways:

Induction coils

- Any booster feature in operation will be switched off.
- The set power level is reduced.
- The cooking zone switches off automatically. *Err* will flash alternately with *044* in the timer display.

You can use the cooking zone again as usual when the fault message has gone out.

Cooling elements

- Any booster feature in operation will be switched off.
- The set power level is reduced.
- The cooking zones switch off automatically.

The affected cooking areas can only be used again as usual once the cooling element has cooled down to a safe level.

The overheating protection may be triggered under the following circumstances:

- The pot or pan being used is empty.
- Fat or oil being heated on a high power level.
- Insufficient ventilation to the underside of the cooktop.
- A hot cooking zone being switched on after an interruption to the power supply.

If, despite removing the cause, the overheating protection mechanism triggers again, contact Miele.



Programming



You can adapt the programming of the cooktop to your personal needs. Several settings can be altered in succession.

After accessing programming mode, the  symbol appears and *PC* will appear in the timer display. After a few seconds *P:01* (Programme 01) will flash alternately with *C:01* (Code) in the timer display.

Changing the programming

Calling up programming mode

The  sensor is located approx. 1 cm (index finger width) to the left of the  sensor.

- **With the cooktop switched off,** touch and hold the  and  sensors together until the  symbol lights up and *PC* appears in the timer display.

Setting a programme

For a two-digit programme number you need to first set the tens position.

- While the programme is visible in the display (e.g. *P:01*), press the  sensor repeatedly until the number for the programme you want appears in the display or touch the appropriate number on the numerical display.

Setting the code

- While the code is visible in the display (e.g. $\mathcal{L}:\mathcal{D}1$), press the \oplus sensor control repeatedly until the number for the code you want appears in the display or touch the appropriate number on the numerical display.

How to save settings

- Whilst the programme is displayed (e.g. $\mathcal{P}:\mathcal{D}1$), touch the $\textcircled{1}$ sensor until the displays go out.

How to avoid saving the settings

- While the code is displayed (e.g. $\mathcal{L}:\mathcal{D}1$), touch the $\textcircled{1}$ sensor until the displays go out.

Programming

| Programme ¹ | | Code ² | Settings |
|------------------------|--|-------------------|---|
| P:01 | Demonstration mode | C:00 | Demonstration mode off |
| | | C:01 | Demo mode on ³ |
| P:03 | Factory default setting | C:00 | Do not restore the factory default settings |
| | | C:01 | Restore factory default settings |
| P:04 | Setting range for power levels | C:00 | 9 power levels + Booster |
| | | C:01 | 17 power levels + Booster ⁴ |
| P:06 | Confirmation tone when a sensor control is touched | C:00 | Off ⁵ |
| | | C:01 | Quiet |
| | | C:02 | Medium |
| | | C:03 | Loud |
| P:07 | Timer signal tone | C:00 | Off |
| | | C:01 | Quiet |
| | | C:02 | Medium |
| | | C:03 | Loud |
| P:08 | System lock | C:00 | System lock can only be activated manually |
| | | C:01 | Activating the system lock automatically |

| Programme ¹ | | Code ² | Settings |
|------------------------|--------------------------------|-------------------|--|
| P:09 | Maximum operating time | C:00 | Safety setting 0 |
| | | C:01 | Safety setting 1 |
| | | C:02 | Safety setting 2 |
| P:10 | Signing Wi-Fi on | C:00 | Not active/deactivated |
| | | C:01 | Active but not configured |
| | | C:02 | Active and configured (cannot be selected; displays whether connection was successful) |
| | | C:03 | Connection possible via WPS push button |
| | | C:04 | Wi-Fi is reset to default (C:00) |
| | | C:05 | Direct Wi-Fi connection of cooktop and external rangehood without Miele App (Con@ctivity) |
| P:12 | Sensor controls reaction speed | C:00 | Slow |
| | | C:01 | Normal |
| | | C:02 | Fast |
| P:15 | Permanent pan recognition | C:00 | Permanent pan recognition off |
| | | C:01 | Permanent pan recognition on |

Programming

| Programme ¹ | | Code ² | Settings |
|------------------------|--------------------------|-------------------|----------|
| P:25 | Keeping warm temperature | C:00 | 50 °C |
| | | C:01 | 55 °C |
| | | C:02 | 60 °C |
| | | C:03 | 65 °C |
| | | C:04 | 70 °C |
| | | C:05 | 75 °C |
| | | C:06 | 80 °C |
| | | C:07 | 85 °C |
| | | C:08 | 90 °C |

¹ Unlisted programmes are not assigned.

² The factory default setting is shown in bold.

³ After the cooktop has been switched on, *dE* appears in the timer display for a few seconds.

⁴ In the text and charts the extended power levels are shown with a dot after the number for better understanding.

⁵ The confirmation tone of the On/Off sensor control cannot be switched off.

 Risk of burning due to hot surfaces!

The cooking zones will be hot after use.

Switch the cooktop off.

Allow the cooking zones to cool down before cleaning the cooktop.

 Risk of damage due to moisture ingress.

The steam from a steam cleaner could reach electrical components and cause a short circuit.

Do not use a steam cleaner to clean the cooktop.

The use of unsuitable cleaning agents can cause the surfaces to discolour or alter. All surfaces are susceptible to scratching.

Remove any residual cleaning agent immediately.

Never use abrasive sponges or cleaning agents.

- Clean the cooktop after every use.
- Dry the cooktop thoroughly after every cleaning to avoid limescale residue.

Unsuitable cleaning agents

To avoid damaging the surfaces of the appliance, do not use:

- washing-up liquid
- cleaning agents containing soda, alkalines, ammonia, acids or chlorides
- cleaning agents containing descaling agents
- stain and rust removers
- abrasive cleaning agents, e.g. powder cleaners and cream cleaners
- solvent-based cleaning agents
- dishwasher cleaners
- grill and oven cleaners
- glass cleaning agents
- hard, abrasive brushes or sponges (e.g. pot scourers), or sponges which have been previously used and still contain abrasive cleaning agents
- dirt eraser sponges

Cleaning and care

Cleaning the ceramic surface



Risk of damage by pointed objects.

The seal between the cooktop and the worktop could be damaged. The seal between the ceramic surface and the frame could be damaged.

Do not use pointed objects for cleaning.

Do not use washing-up liquid to clean the appliance. Using washing-up liquid will not remove all soiling and residues. An invisible film can develop that can lead to discolouration of the ceramic glass surface. This discolouration cannot be removed.

Clean the ceramic surface regularly with a proprietary ceramic glass cleaning agent.

- Remove any coarse soiling with a damp cloth and more stubborn soiling with a glass scraper.
- Then clean the ceramic glass surface with the Miele ceramic and stainless steel cooktop cleaner (see “Optional accessories”) or with a proprietary ceramic glass cleaner applied with paper towel or a clean cloth. Do not apply the cleaner while the cooktop is still hot, as this can result in marking. Please follow the cleaning agent manufacturer's instructions.
- Finally wipe the cooktop with a damp cloth and dry it with a soft, dry cloth.

Residues can burn onto the cooktop the next time it is used and cause damage to the glass ceramic surface. Ensure that all cleaner residues are removed.

- **Spots** caused by limescale, water and aluminium residues (spots with a metallic appearance) can be removed using the Miele ceramic and stainless steel cooktop cleaner.



Risk of burning due to hot surfaces!

The cooking zones are hot during use. Wear oven gloves when removing residues of sugar, plastic or aluminium foil from a hot cooktop with a glass scraper.

- Should any **sugar, plastic or aluminium foil** spill or fall onto a hot cooking zone while it is in use, first switch off the appliance.
- Then carefully scrape off these residues **immediately** whilst they are still hot, using a shielded scraper blade suitable for use on glass.
- Afterwards, clean the ceramic surface in its cooled state, as described above.

Cover grille/Grease filter/ Charcoal filter

The cover grille and the reusable metal grease filter in the downdraft extractor remove solid particles from kitchen vapours (grease, dust, etc.) and therefore prevent soiling of the downdraft extractor. Accumulated grease solidifies over a longer period of time and makes cleaning more difficult. The grease filter should therefore be cleaned at least every 3 to 4 weeks.

 Risk of fire due to soiled grease filter.

Grease collected in the grease filter can ignite.

Clean the grease filter regularly.

Removing the cover grille

Risk of damage to the cover grille.

Pull the cover grille vertically out of the top of the KMDA.

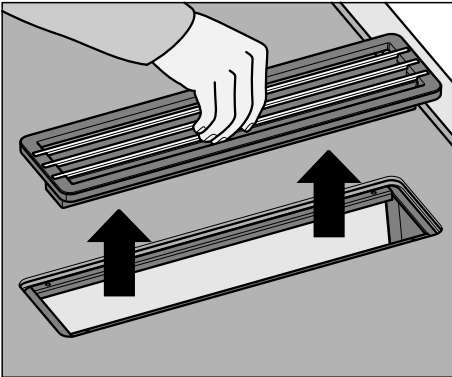

- Take hold of the cover grille in the centre of the bars.
- Pull the cover grille up vertically.

Removing the grease filter

- Remove the cover grille.
- Carefully remove the grease filter. Ensure that you do not tilt the grease filter.
- Pour out any liquid which has collected at the bottom of the grease filter.

Fitting the grease filter

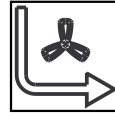

The grease filter has a symbol on the front. The arrow points to the right or left.

- Insert the grease filter so that the arrow is pointing to the opening inside the casing.

Cleaning and care

Cleaning the grease filter and cover grille by hand

- Clean the cover grille and the grease filter with a soft nylon brush in a mild solution of hot water and a little washing-up liquid. Do not use concentrated washing-up liquid.

Cleaning the grease filter and cover grille in the dishwasher

- Place the cover grille upright in the lower basket.
- Place the grease filter with its base facing upwards in the lower basket. Ensure the spray arm is not obstructed.
- Use a standard household dishwasher detergent.
- Select a dishwasher programme with a maximum wash temperature of:
 - 55 °C for the cover grille
 - 65 °C for the grease filter

Depending on the detergent used, cleaning the grease filter in a dishwasher can cause permanent discolouration to the internal surfaces of the filter. This will not affect the functioning of the grease filter in any way.

Cleaning the extractor drip tray

Clean the drip tray if spillage or boiling over has resulted in liquids getting into the extractor.

- Remove and clean the grease filter as described in “Cleaning and care – Grease filter/Cover grille”.

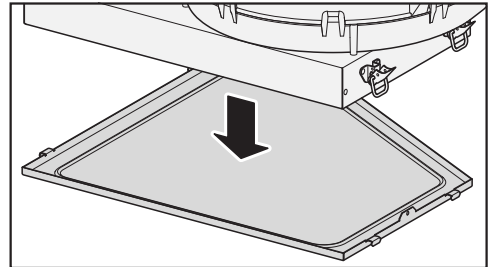

- Hold the drip tray securely and open the 4 catches (2 on the right and 2 on the left). Carefully remove the tray from the casing, making sure it is kept horizontal.
- Pour out the liquid.
- Clean and dry the drip tray.
- Also clean and dry accessible areas inside the extractor.
- Fasten the drip tray back onto the casing.
- Refit the grease filter and the cover grille.

Internal surfaces of the extractor

- When removing the grease filter for cleaning, also clean off any accessible oil or fat build-up from the casing. Doing so will prevent a fire hazard.

Resetting the grease filter operating hours counter

After cleaning the grease filter, the operating hours counter needs to be reset.

- Touch the  sensor for 3 seconds.

The sensor will go out.

Reactivating the charcoal filter

The charcoal filter needs to be reactivated after 120 operating hours. The  sensor will light up.

- Reactivate the charcoal filter as described in the operating and installation instructions supplied with the recirculation box.

Resetting the charcoal filter operating hours counter

- Touch the  sensor for 3 seconds.

The sensor will go out.

Problem solving guide

Many malfunctions and minor faults that can occur in daily operation can be corrected without contacting Miele. This will save you time and money because you will not need a service call.

You can find information on how to remedy faults yourself at www.miele.com.au/service or www.miele.co.nz/service and on the Miele website.

Please note, however, that a call-out charge will be applied to unnecessary service visits where the problem could have been rectified as described in these operating instructions.

Messages in the display

| Problem | Possible cause and remedy |
|--|--|
| <i>Err</i> flashes alternately with 30 in the timer display and a tone will sound. | The cooktop is incorrectly connected. <ul style="list-style-type: none">■ Disconnect the cooktop from the electricity supply.■ Contact Miele. The cooktop must be connected to the mains according to the wiring diagram. |
| After the cooktop has been switched on, <i>L0C</i> appears in the timer display for a few seconds. | The system lock or safety lock is activated. <ul style="list-style-type: none">■ Deactivate the system lock or safety lock (see "Safety features - System lock / Safety lock"). |
| After the cooktop has been switched on, <i>dE</i> appears in the timer display for a few seconds. The cooking zones do not heat up. | The cooktop is in demonstration mode. <ul style="list-style-type: none">■ Touch the 0 sensor on the numerical display.■ Then touch the 0 and 2 sensors at the same time until <i>dE</i> flashes alternately with <i>OFF</i> in the timer display. |
| The cooktop has switched off automatically. When the cooktop is switched back on, <i>L</i> appears above the On/Off ① sensor. | One or more of the sensors are covered, e.g. by finger contact, food boiling over or an object. <ul style="list-style-type: none">■ Clean off any dirt and/or remove the object (see "Safety features - Safety switch-off"). |
| <i>Err</i> will flash alternately with 044 in the timer display. | The overheating protection mechanism has been activated. <ul style="list-style-type: none">■ See "Safety features - Overheating protection". |

Problem solving guide

| Problem | Possible cause and remedy |
|--|--|
| <i>Err</i> flashes alternately with 047, 048 or 049 in the timer display. | <p>The fan is blocked or defective.</p> <ul style="list-style-type: none"> ■ Make sure the fan has not been blocked by an object. ■ Remove the obstruction. ■ If this fault code continues to appear in the display, contact Miele. |
| In the timer display E-number, e.g. E-O, will flash alternately with 120, 121, 122, 123, 124, 125, 126, or 127. | <p>The fan is blocked or defective.</p> <ul style="list-style-type: none"> ■ Make sure the fan has not been blocked by an object. ■ Remove the obstruction. ■ If this fault code continues to appear in the display, contact Miele. |
| A message not listed in this table is appearing in the timer display. | <p>There is an electronic unit fault.</p> <ul style="list-style-type: none"> ■ Interrupt the power supply to the cooktop for approx. 1 minute. ■ If the problem persists after power is restored, please contact Miele. |

Unexpected behaviour

| Problem | Possible cause and remedy |
|---|---|
| The power level selected is flashing. | <p>There is no pan on the cooking zone, or the pan is unsuitable.</p> <ul style="list-style-type: none"> ■ Use suitable pans (see “Cookware - Suitable pans”). |
| Power level 9 is automatically reduced if you also set power level 9 for the connected cooking zone. | <p>Operating both zones at power level 9 exceeds the permitted maximum power for the two zones.</p> <ul style="list-style-type: none"> ■ Use a different cooking zone. |
| A cooking zone switches itself off automatically. | <p>It has been operated for too long.</p> <ul style="list-style-type: none"> ■ You can use the cooking zone again by switching it back on (see “Safety features - Safety switch-off”). |
| A cooking zone is not working in the usual way on the power level selected. | <p>The overheating protection mechanism has been activated.</p> <ul style="list-style-type: none"> ■ See “Safety features - Overheating protection”. |
| A cooking zone or the whole cooktop switches off automatically. | <p>The overheating protection mechanism has been activated.</p> <ul style="list-style-type: none"> ■ See “Safety features - Overheating protection”. |

Problem solving guide

| Problem | Possible cause and remedy |
|--|---|
| The Booster has automatically switched off early. | <p>The overheating protection mechanism has been activated.</p> <ul style="list-style-type: none"> ■ See “Safety features - Overheating protection”. |



Unsatisfactory results

| Problem | Possible cause and remedy |
|--|---|
| The food in the pan hardly heats up or does not heat up at all when the Auto heat-up function is switched on. | <p>There is too much food in the pan.</p> <ul style="list-style-type: none"> ■ Start cooking at the highest power level and then turn down to a lower one manually later on. |
| | <p>The pan is not conducting heat properly.</p> <ul style="list-style-type: none"> ■ Use a different pan which is better able to conduct heat. |

General problems or technical faults

| Problem | Possible cause and remedy |
|--|---|
| The cooktop or cooking zones do not switch on. | <p>There is no power to the cooktop.</p> <ul style="list-style-type: none"> ■ Check if the circuit breaker has tripped. Contact an electrician or Miele (for the minimum fuse rating, see data plate). |
| | <p>There may be a technical fault.</p> <ul style="list-style-type: none"> ■ Disconnect the cooktop from the mains electricity supply for approx. 1 minute. To do this: <ul style="list-style-type: none"> – switch off at the wall socket and withdraw the plug, or – switch off at the residual current device. ■ If, after switching the circuit breaker or residual current device back on, the appliance will still not switch on, contact a qualified electrician or Miele. |
| A smell and vapours are given off when the new appliance is being used. | <p>The metal components have a protective coating. When the appliance is used for the first time, this causes a smell and possibly also vapour. The material from which the induction coils are made also gives off a smell in the first few hours of operation. This smell will be less noticeable with each subsequent use before dissipating completely. The smell and any vapours given off do not indicate a faulty connection or appliance and they are not hazardous to health.</p> |

Problem solving guide

| Problem | Possible cause and remedy |
|--|--|
| A noise can be heard after the appliance is switched off. | The fan will continue running until the cooktop has cooled down. It will then switch itself off automatically. |
| Liquid has entered the extractor. | <p>Due to boiling over or spillage, liquid has made its way through the cover grille into the extractor. The base of the grease filter can hold approx. 250 ml of liquid. The drip tray underneath the housing can hold a further 250 ml of liquid.</p> <ul style="list-style-type: none"> ■ Switch the extractor off. ■ Clean the grease filter, the drip tray and the inside of the housing (see "Cleaning and care"). |
| Extraction performance has decreased. Extraction noise has increased. | <p>Objects (e.g. a cloth) have been drawn into the extractor.</p> <ul style="list-style-type: none"> ■ Switch the extractor off. ■ Remove the grease filter (see "Cleaning and care – Cleaning the grease filter"). ■ Remove any objects from the grease filter. |
| The  sensor is lit up. | <p>The charcoal filter needs to be reactivated.</p> <ul style="list-style-type: none"> ■ If the extractor is being operated in Recirculation mode, reactivate the charcoal filter as described in the operating and installation instructions supplied with the recirculation box. Reset the operating hours counter (see "Cleaning and care – Resetting the charcoal filter operating hours counter" in these operating and installation instructions). ■ If the extractor is being operated in Extraction mode, reset the operating hours counter (see "Cleaning and care" – Resetting the charcoal filter operating hours counter" in these operating and installation instructions). |
| The  sensor is lit up. | <p>The grease filter must be cleaned.</p> <ul style="list-style-type: none"> ■ Clean the grease filter as described in "Cleaning and care – Grease filter/Cover grille". |

Optional accessories

Miele offers a range of useful accessories, as well as cleaning and conditioning products for your appliance.

These products can be ordered from the Miele online shop.

They can also be ordered directly from Miele (see end of this booklet for contact details).

Cookware

Miele offers a wide range of cookware. These have all been optimised in terms of functionality and dimensions for Miele appliances. Detailed information can be found on the Miele website.

Cleaning and care products

Original Miele ceramic and stainless steel cooktop cleaner 250 ml



Removes heavy soiling, limescale deposits and aluminium residues.

Original Miele all purpose microfibre cloth

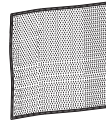

Removes finger marks and light soiling.

Safety instructions for installation

 Risk of damage from incorrect installation.
Incorrect installation can cause damage to the cooktop.
The cooktop must only be installed by a qualified person.

 Danger of electric shock!
Incorrect connection to the power supply may result in an electric shock.
The cooktop must be connected to the power supply by a qualified electrician.

 Damage from falling objects.
Take care not to damage the cooktop when fitting wall units or a rangehood above it.
Fit the wall units and the rangehood before the cooktop.

- ▶ The veneer or laminate coatings of worktops (or adjacent kitchen units) must be treated with 100 °C heat-resistant adhesive which will not dissolve or distort. Any splashbacks must be of heat-resistant material.
- ▶ The cooktop must not be installed over a fridge, fridge-freezer, freezer, dishwasher, washing machine, washer-dryer or tumble dryer.
- ▶ A gas cooktop must not be installed adjacent to this cooktop.
- ▶ This cooktop must not be installed above a cooker or oven unless it has a built-in cooling fan.
- ▶ After installation, ensure that nothing can come into contact with the connection cable and that it is without hindrance.
- ▶ The connection cable may not come into contact with any moving kitchen component (e.g. a drawer) or be subject to mechanical obstruction which could damage it.
- ▶ Carefully observe the safety clearances listed on the following pages.
- ▶ All ducting, pipework and fittings must be of non-flammable material and comply with all relevant national and local building regulations.
- ▶ The appliance must not be connected to a chimney or vent flue which is in current use for exhausting fumes from appliances burning gas or other fuels. Neither should it be connected to ducting which ventilates rooms with fireplaces.

Installation

- ▶ If exhaust air is to be extracted into a chimney or ventilation duct no longer used for other purposes, seek professional advice.
- ▶ The extracted air drawn into the extractor must not be routed into the base unit, as this will damage the cabinet. The extracted air must be routed outside through ducting (extraction mode) or back into the room through the recirculation box (recirculation mode).

Safety distances

Safety distance above the cooktop

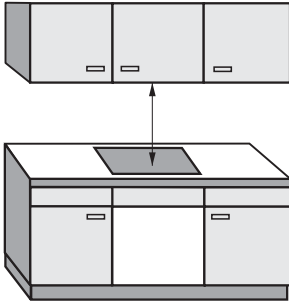

The safety distance specified by the manufacturer of the rangehood must be maintained between the cooktop and the rangehood above it.

If the manufacturer's instructions are not available for the rangehood, a minimum safety distance of 500 mm must be maintained.

For any flammable objects, e.g. utensil rails, wall units etc., a minimum safety distance in accordance with 500 mm must be maintained between these objects and the highest part of the cooktop below.

When two or more appliances which have different safety distances are installed together below a rangehood, observe the greatest specified safety distance.

Installation

Safety distances to the sides and back of the appliance

The minimum distance shown below must be maintained between the back edge of the cooktop and a tall unit or wall.

Ideally the cooktop should be installed with plenty of space on either side.

There may be a wall at the rear or a tall unit or wall on one side (right or left), taking into account the distances below.

On the other side, however, no tall unit or wall should stand closer than 200 mm to the edge of the cooktop.

Before installing the cooktop, check that the below clearance requirements are met.

Minimum horizontal distance from the **back edge** of the cooktop to a combustible surface:
50 mm.

Minimum horizontal distance from the **right edge** of the cooktop to a combustible surface:
50 mm.

Minimum horizontal distance from the **left edge** of the cooktop to a combustible surface:
50 mm.

Installation examples

Recirculation mode

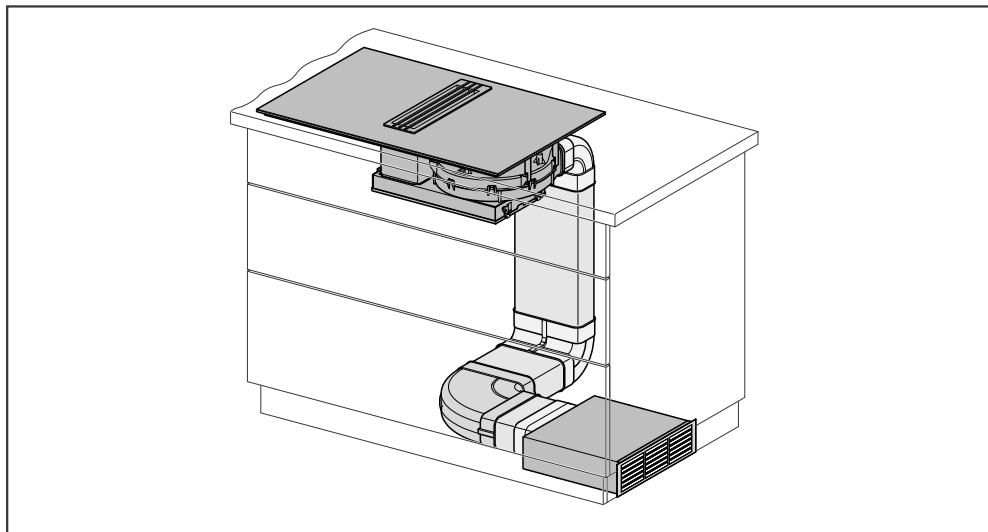

Extraction mode

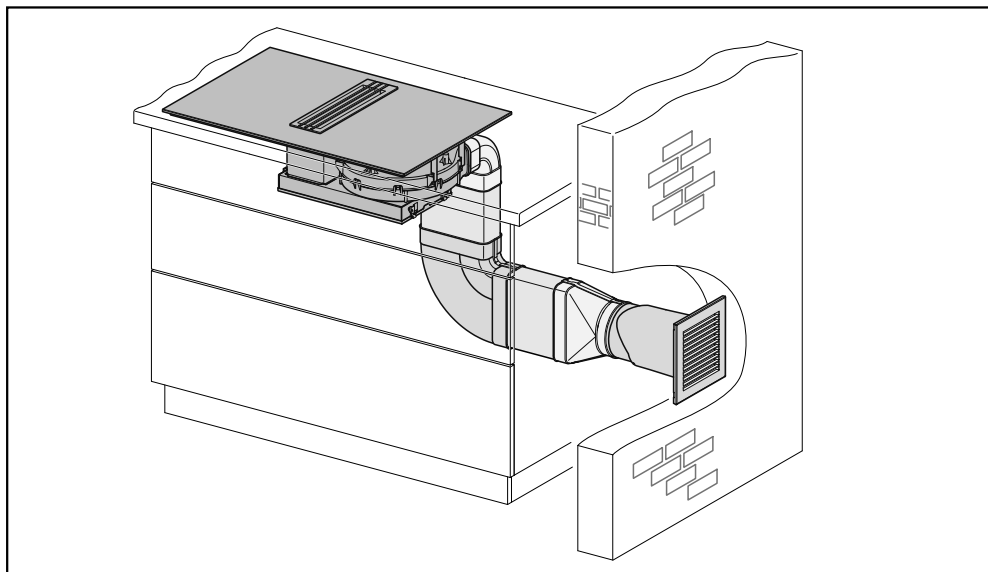

Installation

Installation notes – surface-mounted

Seal between the cooktop and the worktop

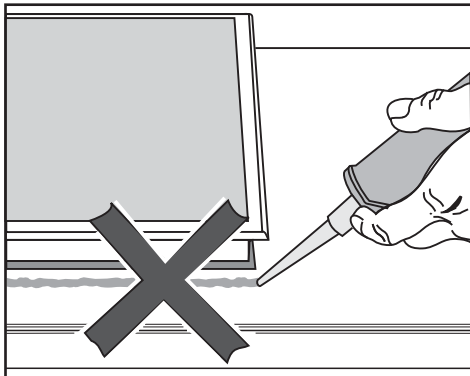

 Damage caused by incorrect installation.

Using sealant under the cooktop could result in damage to the cooktop and the worktop if the cooktop ever needs to be removed for servicing.

Do not use sealant between the cooktop and the worktop. The sealing strip under the edge of the cooktop provides a sufficient seal for the worktop.

Sealing strip

Dismantling the cooktop for service purposes may damage the sealing strip underneath the edge of the cooktop.

Always replace the sealing strip before reinstalling the cooktop.

Tiled worktop

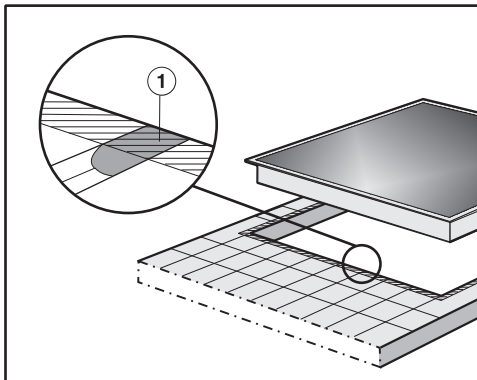

Grout lines ① and the hatched area underneath the cooktop frame must be smooth and even. If they are not, the cooktop will not sit flush with the worktop and the sealing strip underneath the cooktop will not provide a good seal between the cooktop and the worktop.

Minimum plinth height

The minimum plinth height is 100 mm.

Housing unit back panel

The extraction ducting is laid behind the housing unit back panel. The back panel must be removable for maintenance purposes.

Drip tray

The cooktop must be installed so that the drip tray is easily accessible and can be removed for cleaning.

Installation dimensions – Surface-mounted

KMDA 7633 FR, KMDA 7634 FR

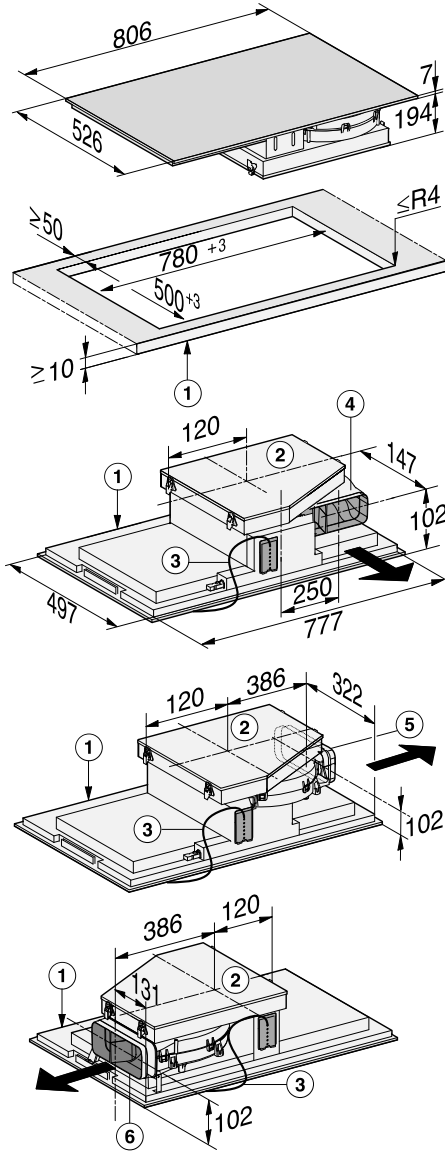

- ① Front
- ② Removable drip tray
- ③ Mains connection box with mains connection cable, L = 1,440 mm
- ④ Air duct connection – at the back (ex-works)
- ⑤ Air duct connection - on the right (conversion required)
- ⑥ Air duct connection - on the left (conversion required)

Installation

KMDA 7633 FL, KMDA 7634 FL

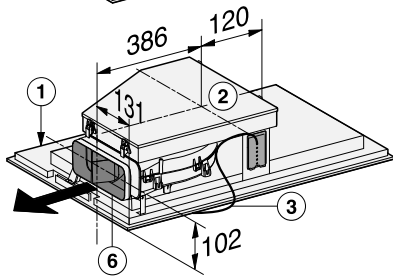
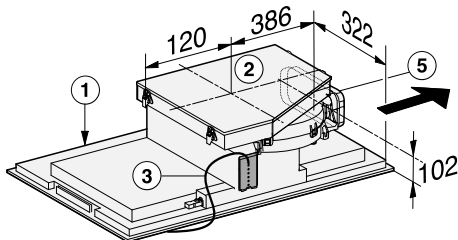
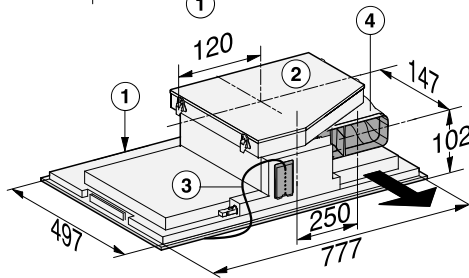
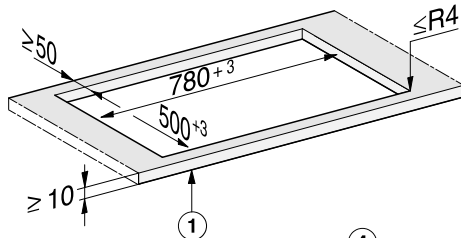
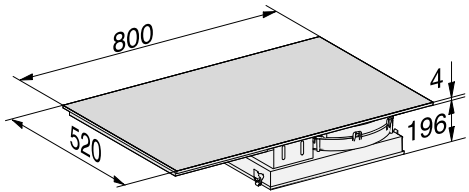

- ① Front
- ② Removable drip tray
- ③ Mains connection box with mains connection cable, L = 1,440 mm
- ④ Air duct connection – at the back (ex-works)
- ⑤ Air duct connection - on the right (conversion required)
- ⑥ Air duct connection - on the left (conversion required)

Worktop depth 600 mm

KMDA 7633 FL, KMDA 7634 FL

KMDA 7633 FR, KMDA 7634 FR

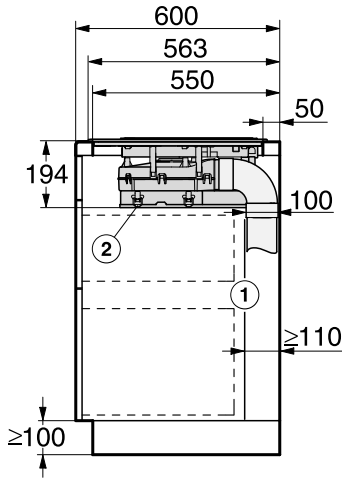

- ① For maintenance work, it must be possible to remove the rear cabinet wall.
The cabinet wall and an adjoining room wall or a piece of furniture must be at least 110 mm¹ apart to ensure sufficient room for the exhaust ducting.
- ② After installation the removable drip tray must be accessible from below. Two quick-release catches have to be opened at the front and rear to remove the tray.

¹ Please check dimensions of locally available ducting as dimensions may vary from manufacturer to manufacturer. N.B. Ducting materials and their installation must conform with local and national regulations.

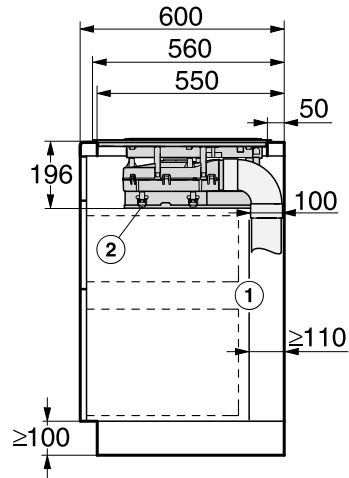

- ① For maintenance work, it must be possible to remove the rear cabinet wall.
The cabinet wall and an adjoining room wall or a piece of furniture must be at least 110 mm¹ apart to ensure sufficient room for the exhaust ducting.
- ② After installation the removable drip tray must be accessible from below. Two quick-release catches have to be opened at the front and rear to remove the tray.

¹ Please check dimensions of locally available ducting as dimensions may vary from manufacturer to manufacturer. N.B. Ducting materials and their installation must conform with local and national regulations.

Installation

Extraction to the rear (standard)

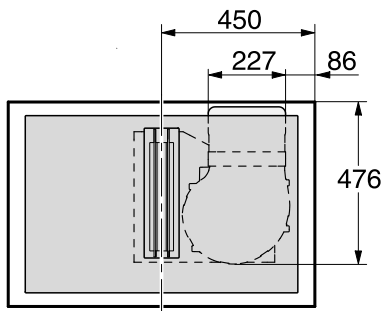

Extraction to the right

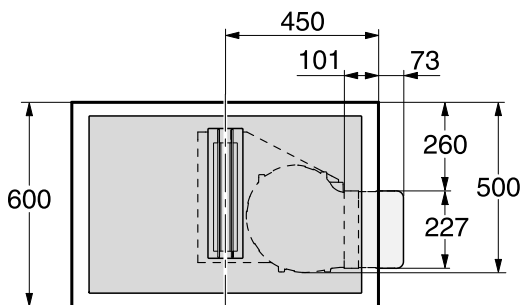

Extraction to the left

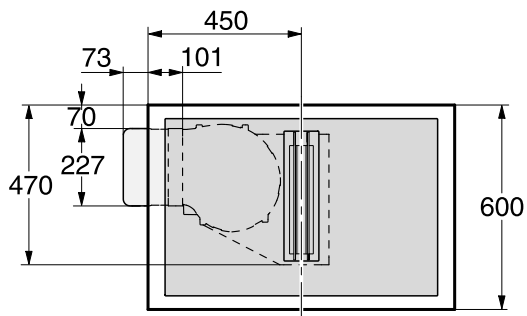

Worktop depth greater than 600 mm

KMDA 7633 FL, KMDA 7634 FL

KMDA 7633 FR, KMDA 7634 FR

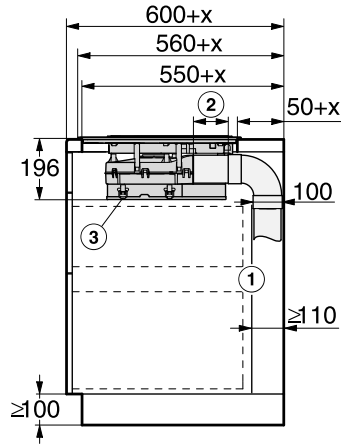
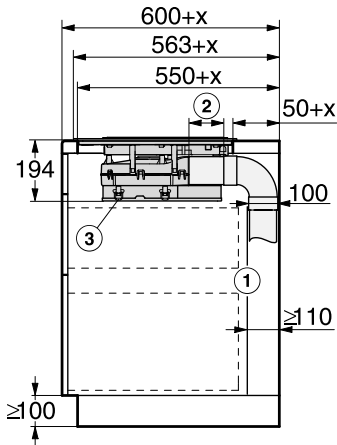

- ① For maintenance work, it must be possible to remove the rear cabinet wall.

The cabinet wall and an adjoining room wall or a piece of furniture must be at least 110 mm¹ apart to ensure sufficient room for the exhaust ducting.

- ② Duct connector, adapted to the worktop depth
- ③ After installation the removable drip tray must be accessible from below. Two quick-release catches have to be opened at the front and rear to remove the tray.

x Dimension of which the worktop is deeper than 600 mm.

¹ Please check dimensions of locally available ducting as dimensions may vary from manufacturer to manufacturer. N.B. Ducting materials and their installation must conform with local and national regulations.

- ① For maintenance work, it must be possible to remove the rear cabinet wall.

The cabinet wall and an adjoining room wall or a piece of furniture must be at least 110 mm¹ apart to ensure sufficient room for the exhaust ducting.

- ② Duct connector, adapted to the worktop depth
- ③ After installation the removable drip tray must be accessible from below. Two quick-release catches have to be opened at the front and rear to remove the tray.

x Dimension of which the worktop is deeper than 600 mm.

¹ Please check dimensions of locally available ducting as dimensions may vary from manufacturer to manufacturer. N.B. Ducting materials and their installation must conform with local and national regulations.

Installation

Extraction to the rear (standard)

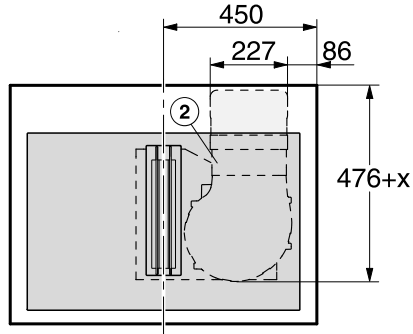

Extraction to the right

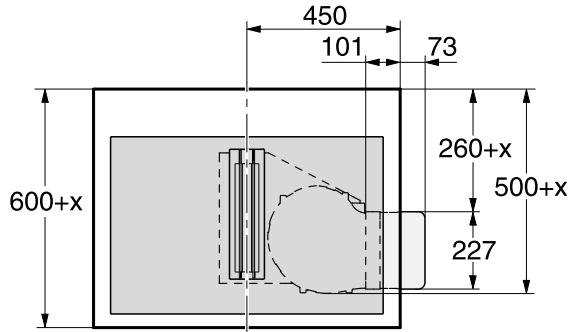

Extraction to the left

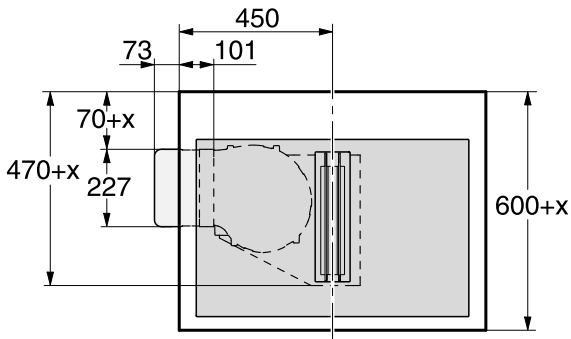

Installation notes – flush-fit

A flush-fit cooktop is suitable only for installation in natural stone (granite, marble), solid wood and tiled worktops. When using a worktop made from any other material, please check first with the worktop manufacturer that it is suitable for installing a flush-fit cooktop.

The internal width of the base unit underneath the appliance must be at least as wide as the inner worktop cut-out (see “Installation – Installation dimensions – Flush-fit”), so that the cooktop is easily accessible from underneath after installation and the bottom half of the casing can be removed for maintenance. If the underside of the cooktop is not freely accessible after installation, any sealant used to plug the gaps around the appliance must be removed to enable the cooktop to be lifted out of the cut-out should this be necessary.

Natural stone worktops

The cooktop is placed directly in the cut-out.

Solid wood worktops, tiled worktops, glass worktops

The cooktop is placed on a wooden frame inside the cut-out. The frame must be provided on site and is not supplied with the appliance.

Sealing strip

Dismantling the cooktop for service purposes may damage the sealing strip underneath the edge of the cooktop.

Always replace the sealing strip before reinstalling the cooktop.

Minimum plinth height

The minimum plinth height is 100 mm.

Housing unit back panel

The extraction ducting is laid behind the housing unit back panel. The back panel must be removable for maintenance purposes.

Drip tray

The cooktop must be installed so that the drip tray is easily accessible and can be removed for cleaning.

Installation

Installation dimensions – Flush

KMDA 7633 FL, KMDA 7634 FL

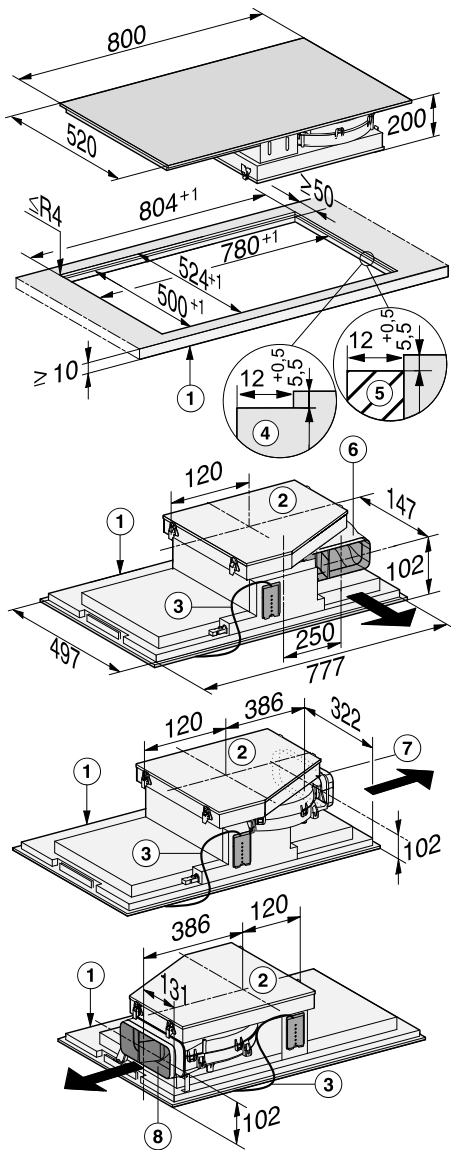

- ② Removable drip tray
- ③ Mains connection box with mains connection cable, L = 1,440 mm
- ④ Stepped cut-out, natural stone worktop
- ⑤ Wooden strip 12 mm (not supplied)
- ⑥ Air duct connection – at the back (ex-works)
- ⑦ Air duct connection - on the right (conversion required)
- ⑧ Air duct connection - on the left (conversion required)

All dimensions are given in mm.

① Front

Worktop depth 600 mm

KMDA 7633 FL, KMDA 7634 FL

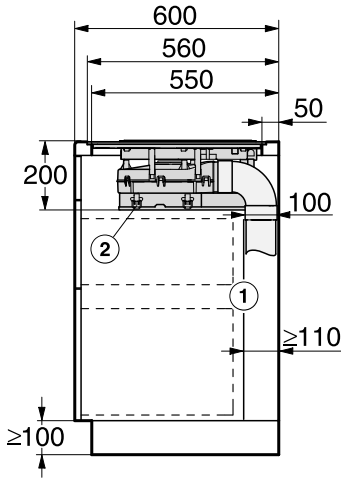

All dimensions are given in mm.

- ① For maintenance work, it must be possible to remove the rear cabinet wall.
The cabinet wall and an adjoining room wall or a piece of furniture must be at least 110 mm¹ apart to ensure sufficient room for the exhaust ducting.
- ② After installation the removable drip tray must be accessible from below.
Two quick-release catches have to be opened at the front and rear to remove the tray.

¹ Please check dimensions of locally available ducting as dimensions may vary from manufacturer to manufacturer. N.B. Ducting materials and their installation must conform with local and national regulations.

Installation

Extraction to the rear (standard)

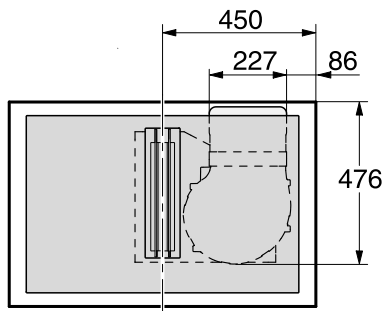

Extraction to the right

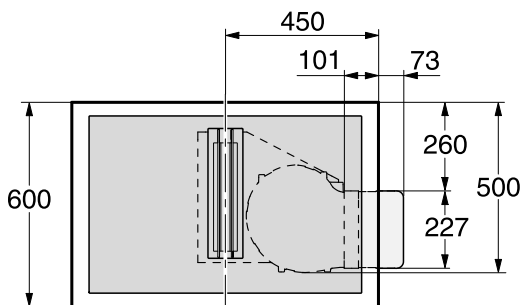

Extraction to the left

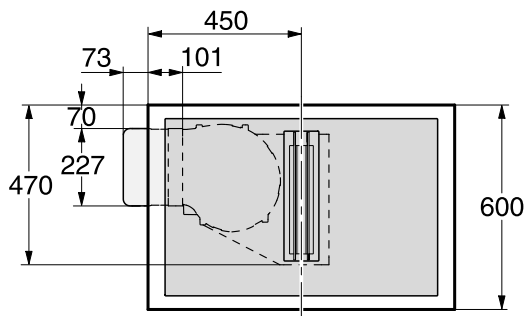

Worktop depth greater than 600 mm

KMDA 7633 FL, KMDA 7634 FL

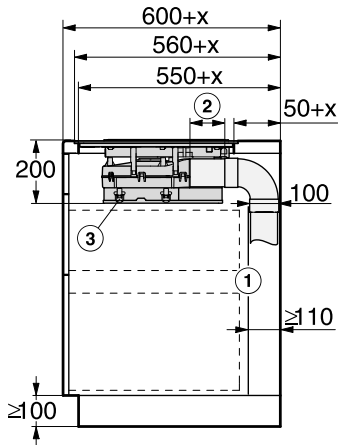

¹ Please check dimensions of locally available ducting as dimensions may vary from manufacturer to manufacturer. N.B. Ducting materials and their installation must conform with local and national regulations.

All dimensions are given in mm.

- ① For maintenance work, it must be possible to remove the rear cabinet wall.
The cabinet wall and an adjoining room wall or a piece of furniture must be at least 110 mm^1 apart to ensure sufficient room for the exhaust ducting.
 - ② Duct connector, adapted to the worktop depth
 - ③ After installation the removable drip tray must be accessible from below. Two quick-release catches have to be opened at the front and rear to remove the tray.
- x Dimension of which the worktop is deeper than 600 mm.

Installation

Extraction to the rear (standard)

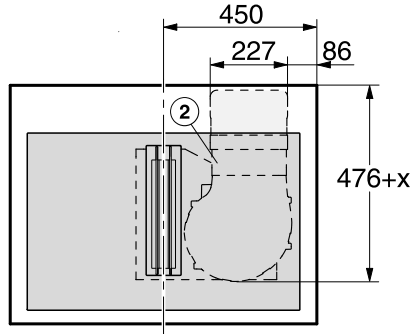

Extraction to the right

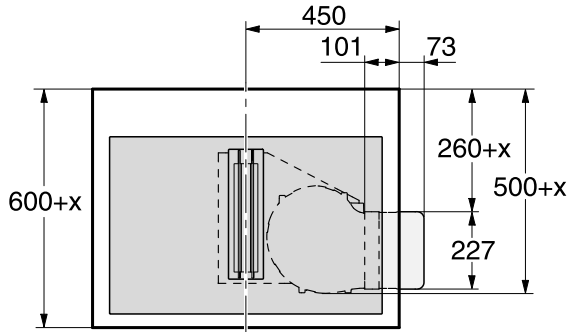

Extraction to the left

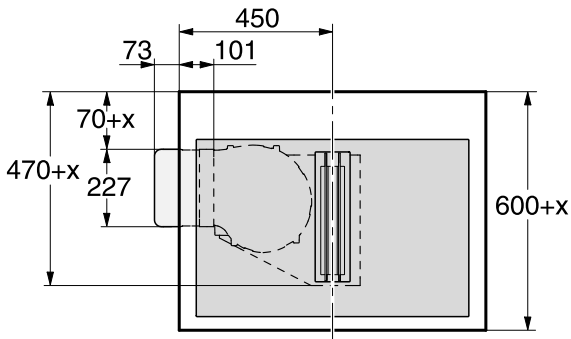

Changing extraction direction

If you modify the extraction direction, the original brackets will no longer be required.

- Use the bracket supplied separately with the extractor once the extraction direction has been modified.

Keep the original brackets in case the extraction direction needs to be modified again.

Extraction to the right

- Place the cooktop on its ceramic surface on a soft underlay.

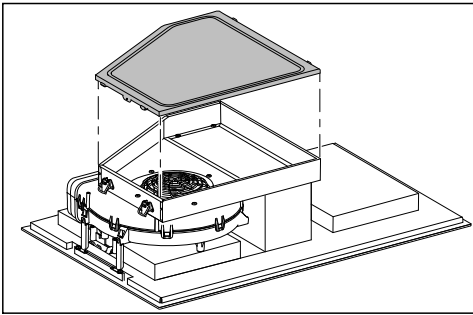

- Release the 4 catches and remove the drip tray.

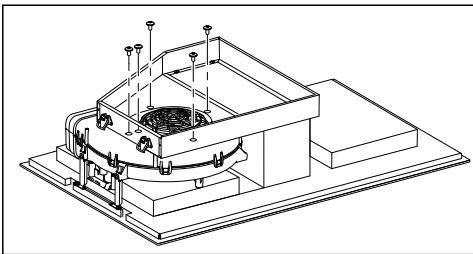

- Undo the 5 screws on the fan.

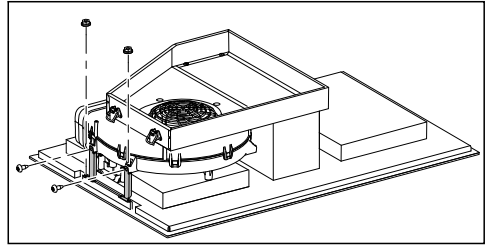

- Undo the fixing brackets.

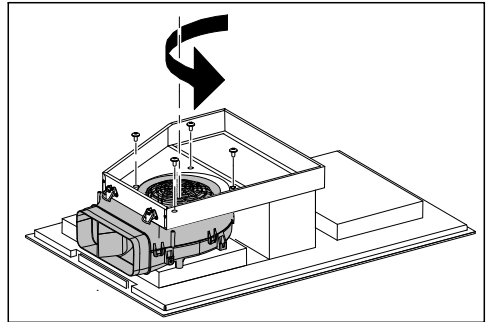

- Rotate the fan by 90°.
- Secure the fan (you only need 4 screws). Make sure that the plastic edge is on the left.

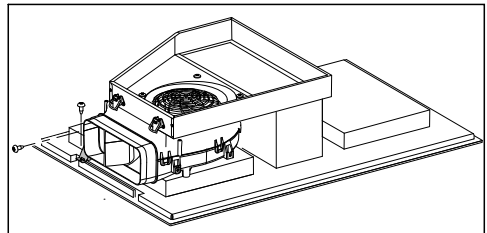

- Use the bracket supplied separately to secure the fan.
- Place the drip tray onto the extractor again and secure the tray using the 4 catches.

Installation

Extraction to the left

- Place the cooktop on its ceramic surface on a soft underlay.

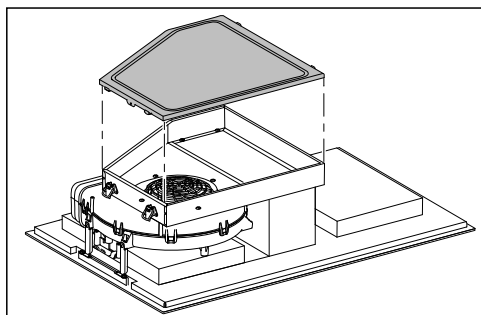

- Release the 4 catches and remove the drip tray.

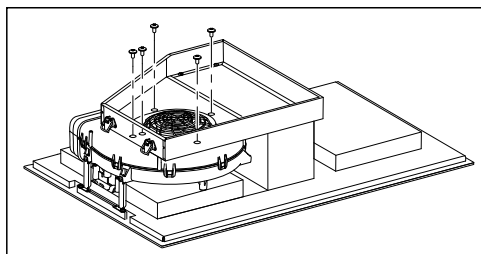

- Undo the 5 screws on the fan.

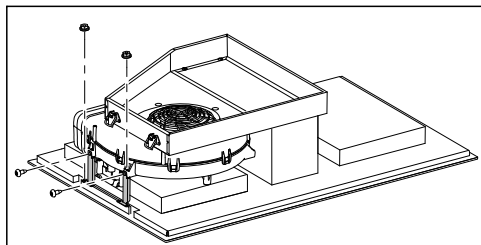

- Undo the fixing brackets.

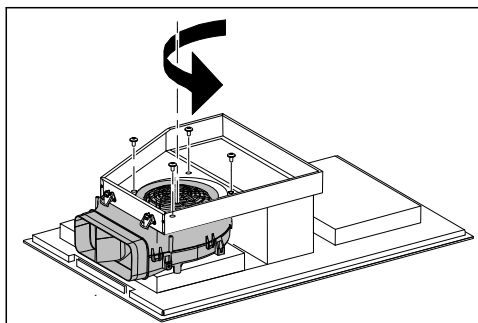

- Rotate the fan by 90°.
- Secure the fan (you only need 4 screws). Make sure that the plastic edge is on the left.

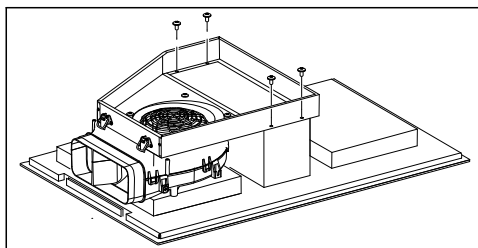

- Undo the 4 screws on the frame.

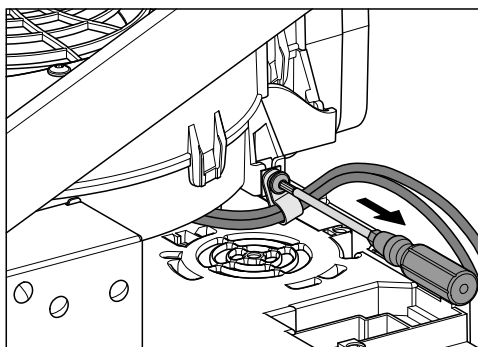

- Loosen the cable tie.

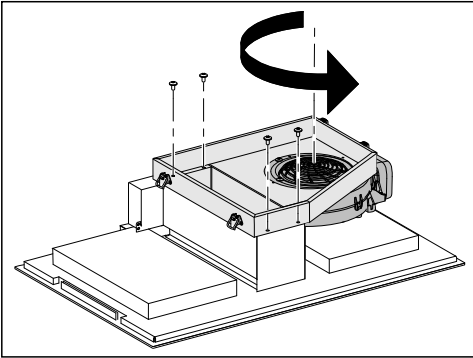

- Slide the frame outwards towards the current extraction direction and tilt up to remove one side. Then slide in the opposite direction to remove the entire frame and fan. Then turn both 180°.

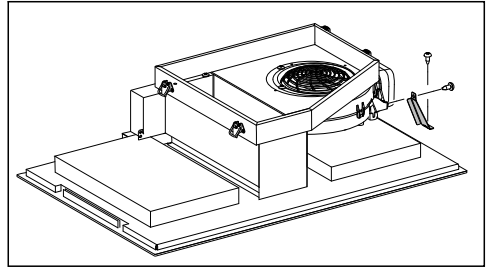

- Use the bracket supplied separately to secure the fan.
- Place the drip tray onto the extractor again and secure the tray using the 4 catches.

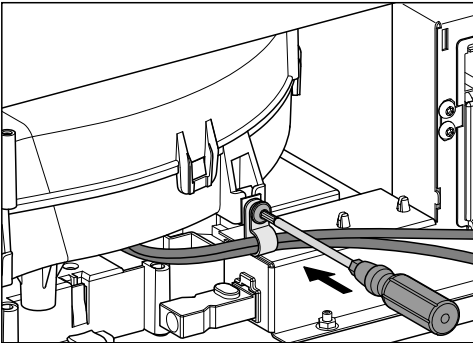

- Guide the cable under the fan.
- Reattach the cable tie.
- Refit the 4 screws in the frame.

Installation

Connection to window contact, if required

 The window contact is connected to the mains voltage. Danger of electric shock! Disconnect the cooktop from the mains electricity supply before connecting the switching mechanism. The connection cable of the switching system must only be connected by a suitably qualified and competent electrician.

The connection cable of the switching system must be of the correct type and cross-sectional area in strict accordance with current national and local safety regulations and must not exceed 2.0 m in length.

The switching system must be equipped with a potential-free contact suitable for 230 V, 1 A. The extractor is switched off when the switch is open.

Only use suitable switching systems (e.g. window contact switches, pressure switches).

The switching system must be suitable for use with inductive loads (BLDC motor).

Use switching systems in strict accordance with current national and local safety regulations.

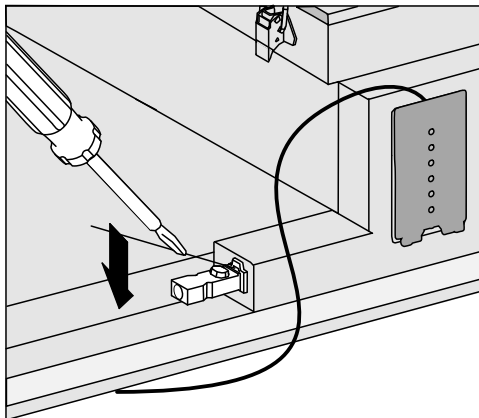

- Loosen the lug and pull the plug out.

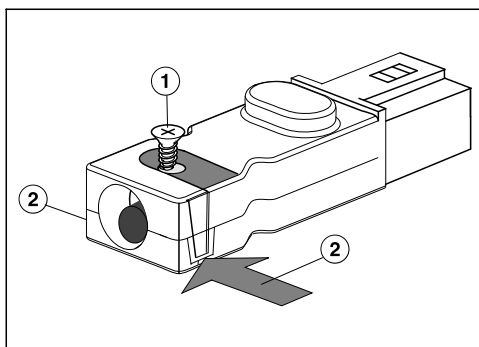

- Loosen the strain relief screw ① and unlock the casing on both sides ②.
- Open the casing.
- Remove the stopper.

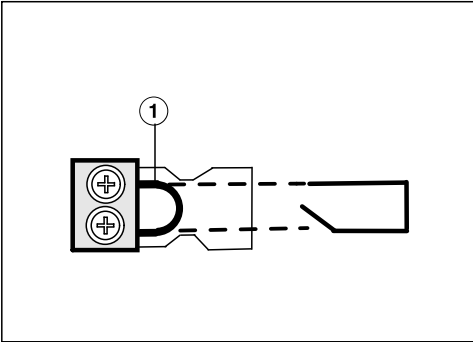

- Exchange the jumper ① with the connection cable of the switching system.
- Close the casing.
- Tighten the strain relief screw.
- Reinsert the plug.

Installation

Surface-mounted installation

- Create the worktop cut-out.
Remember to maintain the minimum safety distances (see “Installation – Safety distances”).
- Seal the cut surfaces of **wooden worktops** with a suitable sealant to avoid swelling caused by moisture. The sealant must be heat-resistant.

Make sure the sealant does not come into contact with the top surface of the worktop.

- Attach the sealing strip provided underneath the edge of the cooktop. Do not apply the sealing strip under tension.
- Feed the mains connection cable for the cooktop down through the worktop cut-out.
- Place the cooktop centrally in the cut-out. When doing this, make sure that the seal of the appliance sits flush with the worktop on all sides. This is important to ensure an effective seal with the worktop.

Do not use any additional sealant (e.g. silicone).

If the seal does not meet the worktop correctly on the corners, the corner radius ($\leq R4$) can be carefully scribed to suit.

- Connect the cooktop to the mains electricity supply (see "Installation – Electrical connection").
- Check that the cooktop works.

Flush-fit installation

- Create the worktop cut-out.
Remember to maintain the minimum safety distances (see "Installation – Safety distances").
- Solid wood, tiled and glass worktops:
Fix a wooden frame 5.5 mm below the top edge of the worktop (see the diagram in "Installation – Installation dimensions – Flush").
- Feed the mains connection cable down through the worktop cut-out.
- Centre the cooktop in the cut-out.

The gap between the ceramic surface and the worktop must be at least 2 mm wide. This is required so that the cooktop can be sealed.

- Connect the cooktop to the mains electricity supply (see "Installation – Electrical connection").
- Check that the cooktop works.
- Seal the gap between the cooktop and worktop with a silicone sealant that is heat-resistant to at least 160 °C.

 Damage caused by unsuitable sealant.

Unsuitable sealant can damage natural stone.

For natural stone worktops and natural stone tiles, only use silicone sealant that is specially formulated for natural stone. Please follow the manufacturer's instructions.

Installation

Exhaust ducting

! If the extractor is used at the same time as a heating appliance that relies on oxygen from the same room, there is a risk of toxic fumes. It is essential that the "Warning and Safety instructions" are observed.

The extractor should be installed according to local and national building regulations. Seek approval from the building inspector where necessary.

The extractor has an exhaust connection of 222 x 89 mm.

- Only use smooth pipes or flexible ducting made from approved non-flammable materials for exhaust ducting.
- To achieve the most efficient air extraction with the lowest noise levels, please note the following:
 - The cross-section of the exhaust ducting must not be smaller than the cross-section of the exhaust connection (see the appliance dimensions).
 - The exhaust ducting should be as short and straight as possible.
 - Only use wide radius bends.
 - The exhaust ducting must not be kinked or compressed.
 - Ensure that all connections are strong and airtight.

Remember that any constriction of the airflow will reduce extraction performance and increase operating noise.

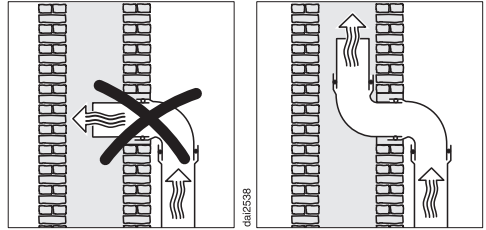

- If the exhaust air is to be ducted into a vent flue, the ducting must be directed in the flow direction of the flue.
- If ducting is to be laid horizontally, it must be laid with a downwards sloping gradient. This is to ensure that condensate cannot drain back into the extractor.
- If the exhaust ducting is to run through rooms, ceiling space, etc. there may be great variations in temperature between the different areas. The problem of condensation will need to be addressed. The exhaust ducting will need to be suitably insulated.

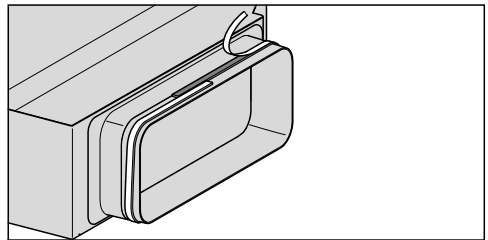

- Stick the supplied sealing strip on the exhaust connection if the ducting does not sit securely up against the exhaust connection.

Electrical connection

 Risk of damage from incorrect connection.

Incorrect installation, maintenance and repairs can be dangerous to users.

Miele cannot be held liable for damage or injury caused by incorrect or unauthorised installation, maintenance or repair work, or by an inadequate or faulty on-site earthing system (e.g. electric shock).

All electrical work must be carried out by a suitably qualified and competent electrician, in strict accordance with current national and local safety regulations, and any additional regulations of the local electricity provider.

After installation, ensure that all electrical components are shielded and cannot be accessed by users.

Total power output

See data plate.

Connection data

The connection data is quoted on the data plate. Please ensure this information matches the household mains supply.

Please see the wiring diagrams for connection.

Residual current device

For extra safety, it is advisable to protect the appliance with a suitable residual current device (RCD) with a trip range of 30 mA.

Disconnecting devices

Connection must be made via a suitable isolator switch which provides disconnection on all poles and which complies with national and local safety regulations. When switched off there must be an all-pole contact gap of at least 3 mm in the isolator switch. The isolator switch must be easily accessible after the appliance has been built in.

Installation

Mains connection cable

The cooktop must be connected to the electrical supply with a special connection cable, type H 05 VV-F (PVC insulated) with a suitable diameter.

Please see the wiring diagram for connection.

See the data plate on the cooktop for the correct voltage and frequency.

Replacing the mains connection cable



Danger of electric shock!

Incorrect connection to the electricity supply may result in an electric shock.

The mains connection cable must only be replaced in accordance with current local and national safety regulations.

When replacing the mains connection cable, it must be replaced with cable type H 05 VV-F (PVC insulated) by a Miele authorised service technician or a suitably qualified and competent electrician in order to avoid a hazard. These cables are available from Miele.

Wiring diagram

Some connection methods are not permitted in all installation locations. Ensure compliance with national regulations and any additional regulations issued by the local electricity provider.

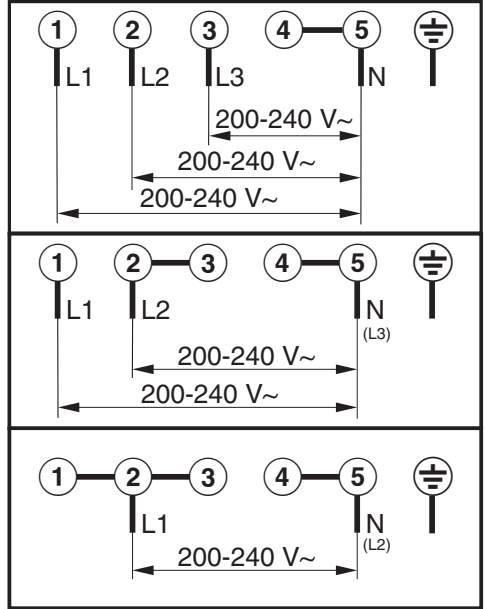

Service

Contact in case of fault

In the event of any faults which you cannot remedy yourself, please contact Miele.

You can book a Miele customer service call-out online at www.miele.com.au/service or www.miele.co.nz/service.

Contact information for Miele can be found at the end of this booklet.

Please quote the model and serial number of your appliance when contacting Miele. This information can be found on the data plate.

Data plate

Adhere the extra data plate stating the model number supplied with the appliance in the space below. Make sure that the model number matches the one specified on the back cover of these operating and installation instructions.

Warranty

The manufacturer's warranty for this appliance is 2 years.

For further information, please refer to your warranty booklet.

Miele Australia Pty. Ltd.

ACN 005 635 398

ABN 96 005 635 398

Level 4, 141 Camberwell Road
Hawthorn East, VIC 3123

1300 464 353 (1300 4 MIELE)

info@miele.com.au

www.miele.com.au

Miele New Zealand Limited

IRD 98 463 631

8 College Hill
Freemans Bay, Auckland 1011

0800 464 353 (0800 4 MIELE)

customercare@miele.co.nz

www.miele.co.nz

Miele Global Headquarters

Germany

Miele & Cie. KG

Carl-Miele-Straße 29

33332 Gütersloh

Federal Republic of Germany

KMDA 7633 FR, KMDA 7633 FL,
KMDA 7634 FR, KMDA 7634 FL