

Installation Plan / Plan d'installation

PG 8591 – PG 8593

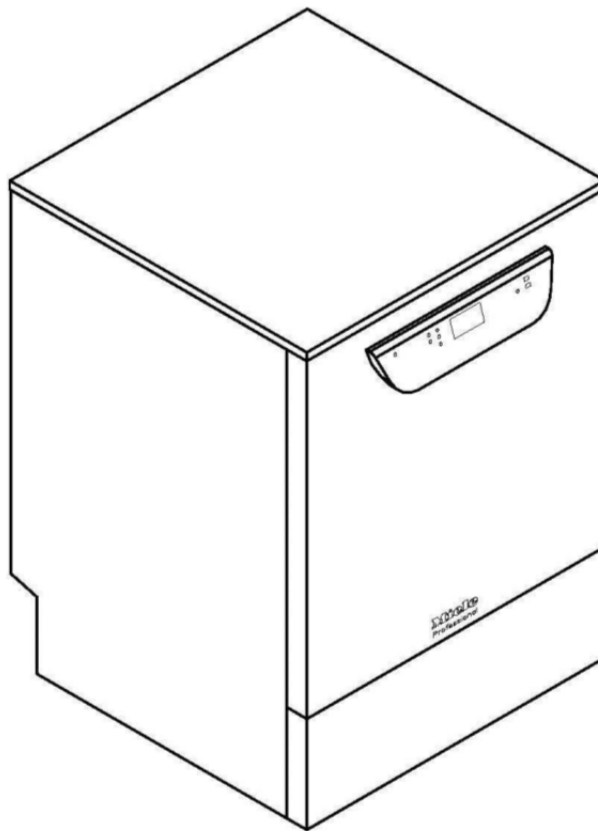

Mat. no.
Version

10 344 180
00

en, fr - CA

Technical data sheet

PG 8591 Washer-disinfector
PG 8593 Laboratory Glassware Washer

Miele
PROFESSIONAL

PG 8591 - 8593

Legend:



Circled, bold-type abbreviations:
Connection required







Abbreviations surrounded by broken circle:
Connection optional or required, depending on model

(EL)	Electrical connection (PG 8591)	Voltage (default) Rated load Fuse rating Minimum cross-section Length of electrical cord (UL 921) with plug Electrical connection	2 AC 208V 60 Hz 6.2 kW 2 x 30 A 3 x AWG 10 approx. 5'9" NEMA L6-30	2 AC 208V 60 Hz 6.2 kW 2 x 30 A 3 x 5.2 mm ² approx. 1.8 m NEMA L6-30
(EL)	Electrical connection (PG 8591)	Voltage (convertible) Rated load Fuse rating Minimum cross-section Length of electrical cord (UL 921) with plug Electrical connection	3 AC 208V 60 Hz 6.2 kW 3 x 20 A 4 x AWG 12 approx. 5'9" NEMA L15-20	3 AC 208V 60 Hz 6.2 kW 3 x 20 A 4 x 3.3 mm ² approx. 1.8 m NEMA L15-20
(EL)	Electrical connection (240V Option PG8591)	Voltage (default) Rated load Fuse rating Minimum cross-section Length of electrical cord (UL 921) with plug Electrical connection	2 AC 240V 60 Hz 6.2 kW 2 x 30 A 3 x AWG 10 approx. 5'9" NEMA L6-30	2 AC 240V 60 Hz 6.2 kW 2 x 30 A 3 x 5.2 mm ² approx. 1.8 m NEMA L6-30
(EL)	Electrical connection (240V Option PG8591)	Voltage (convertible) Rated load Fuse rating Minimum cross-section Length of electrical cord (UL 921) with plug Electrical connection	3 AC 240V 60 Hz 6.2 kW 3 x 20 A 4 x AWG 12 approx. 5'9" NEMA L15-20	3 AC 240V 60 Hz 6.2 kW 3 x 20 A 4 x 3.3 mm ² approx. 1.8 m NEMA L15-20
(EL)	Electrical connection (PG 8593)	Voltage (default) Rated load Fuse rating Minimum cross-section Length of electrical cord (UL 921) with plug Electrical connection	3 AC 208V 60 Hz 6.2 kW 3 x 20 A 4 x AWG 12 approx. 5'9" NEMA L15-20	3 AC 208V 60 Hz 6.2 kW 3 x 20 A 4 x 3.3 mm ² approx. 1.8 m NEMA L15-20
(EL)	Electrical connection (PG 8593)	Voltage (convertible) Rated load Fuse rating Minimum cross-section Length of electrical cord (UL 921) with plug Electrical connection	2 AC 208V 60 Hz 6.2 kW 2 x 30 A 3 x AWG 10 approx. 5'9" NEMA L6-30	2 AC 208V 60 Hz 6.2 kW 2 x 30 A 3 x 5.2 mm ² approx. 1.8 m NEMA L6-30

The machine is supplied with electrical cord and plug. The receptacle must be accessible after machine installation. For hard-wired machines, connection should be made via a suitable mains switch with all-pole isolation. The contact opening between all open contacts must be at least 3 mm wide and the mains switch must be lockable in the open position. If necessary, an equipotential bond with good contact connection must be provided in accordance with all appropriate national and local regulations.

Splash protection class IP 21

	Equipotential bonding and earthing	<p>There is a screw connection point at the back of the machine, to which equipotential bonding can be connected if required.</p> <p>Connect equipotential bonding and protective earth conductor!</p>																													
	Network/printer connection (optional)	<p>Optional machine interface for transmission or process data output</p> <p>Communication module (not supplied)</p> <p>Ethernet module or RS232 module (install electrical sockets near machine if required)</p> <p><i>Connections/installation must comply with IEC 60950.</i></p>																													
	Cold Water	<p>Two cold water connections are required for machines with steam condenser (DK). Use supplied Y-adaptor if only one cold water connection is available.</p> <table border="1" data-bbox="453 645 1402 1115"> <tr> <td>Max. temperature</td> <td>68 °F</td> <td>20 °C</td> </tr> <tr> <td>Max. water hardness</td> <td>73 gpg</td> <td>70 °dH</td> </tr> <tr> <td>Recommended flow pressure</td> <td>29 psi</td> <td>200 kPa</td> </tr> <tr> <td>Min. flow pressure</td> <td>14.5 psi</td> <td>100 kPa</td> </tr> <tr> <td>Max. pressure</td> <td>145 psi</td> <td>1,000 kPa</td> </tr> <tr> <td>Throughput</td> <td>2 gal/min</td> <td>7.5 l/min</td> </tr> <tr> <td>Connection thread - on site (flat sealing)</td> <td>3/4" Male Garden Hose Thread</td> <td>3/4" Male Garden Hose Thread</td> </tr> <tr> <td>Length of connection hose (supplied)</td> <td>approx. 5' 7"</td> <td>approx. 1.7 m</td> </tr> <tr> <td>Length of the steam condenser hose</td> <td>approx. 5' 7"</td> <td>approx. 1.7 m</td> </tr> </table>			Max. temperature	68 °F	20 °C	Max. water hardness	73 gpg	70 °dH	Recommended flow pressure	29 psi	200 kPa	Min. flow pressure	14.5 psi	100 kPa	Max. pressure	145 psi	1,000 kPa	Throughput	2 gal/min	7.5 l/min	Connection thread - on site (flat sealing)	3/4" Male Garden Hose Thread	3/4" Male Garden Hose Thread	Length of connection hose (supplied)	approx. 5' 7"	approx. 1.7 m	Length of the steam condenser hose	approx. 5' 7"	approx. 1.7 m
Max. temperature	68 °F	20 °C																													
Max. water hardness	73 gpg	70 °dH																													
Recommended flow pressure	29 psi	200 kPa																													
Min. flow pressure	14.5 psi	100 kPa																													
Max. pressure	145 psi	1,000 kPa																													
Throughput	2 gal/min	7.5 l/min																													
Connection thread - on site (flat sealing)	3/4" Male Garden Hose Thread	3/4" Male Garden Hose Thread																													
Length of connection hose (supplied)	approx. 5' 7"	approx. 1.7 m																													
Length of the steam condenser hose	approx. 5' 7"	approx. 1.7 m																													
	Hot Water Connection	<table border="1" data-bbox="453 1124 1402 1550"> <tr> <td>Max. temperature</td> <td>150 °F</td> <td>65 °C</td> </tr> <tr> <td>Max. water hardness</td> <td>73 gpg</td> <td>70 °dH</td> </tr> <tr> <td>Recommended flow pressure</td> <td>29 psi</td> <td>200 kPa</td> </tr> <tr> <td>Min. flow pressure</td> <td>5.8 psi</td> <td>40 kPa</td> </tr> <tr> <td>Max. pressure</td> <td>145 psi</td> <td>1,000 kPa</td> </tr> <tr> <td>Throughput</td> <td>2 gal/min</td> <td>7.5 l/min</td> </tr> <tr> <td>Connection thread - on site (flat sealing)</td> <td>3/4" Male Garden Hose Thread</td> <td>3/4" Male Garden Hose Thread</td> </tr> <tr> <td>Length of connection hose (supplied)</td> <td>approx. 5' 7"</td> <td>approx. 1.7 m</td> </tr> </table>			Max. temperature	150 °F	65 °C	Max. water hardness	73 gpg	70 °dH	Recommended flow pressure	29 psi	200 kPa	Min. flow pressure	5.8 psi	40 kPa	Max. pressure	145 psi	1,000 kPa	Throughput	2 gal/min	7.5 l/min	Connection thread - on site (flat sealing)	3/4" Male Garden Hose Thread	3/4" Male Garden Hose Thread	Length of connection hose (supplied)	approx. 5' 7"	approx. 1.7 m			
Max. temperature	150 °F	65 °C																													
Max. water hardness	73 gpg	70 °dH																													
Recommended flow pressure	29 psi	200 kPa																													
Min. flow pressure	5.8 psi	40 kPa																													
Max. pressure	145 psi	1,000 kPa																													
Throughput	2 gal/min	7.5 l/min																													
Connection thread - on site (flat sealing)	3/4" Male Garden Hose Thread	3/4" Male Garden Hose Thread																													
Length of connection hose (supplied)	approx. 5' 7"	approx. 1.7 m																													
	Demineralised water (DI)	<table border="1" data-bbox="453 1559 1402 1921"> <tr> <td>Max. temperature</td> <td>150 °F</td> <td>65 °C</td> </tr> <tr> <td>Recommended flow pressure</td> <td>29 psi</td> <td>200 kPa</td> </tr> <tr> <td>Min. flow pressure</td> <td>4.4 psi</td> <td>30 kPa</td> </tr> <tr> <td>Max. pressure</td> <td>145 psi</td> <td>1,000 kPa</td> </tr> <tr> <td>Connection thread - on site (flat sealing)</td> <td>3/4" Male Garden Hose Thread</td> <td>3/4" Male Garden Hose Thread</td> </tr> <tr> <td>Throughput</td> <td>2 gal/min</td> <td>7.5 l/min</td> </tr> <tr> <td>Length of connection hose (supplied)</td> <td>approx. 5' 7"</td> <td>approx. 1.7 m</td> </tr> </table> <p>Hose from supply container to machine to be fitted on site.</p>			Max. temperature	150 °F	65 °C	Recommended flow pressure	29 psi	200 kPa	Min. flow pressure	4.4 psi	30 kPa	Max. pressure	145 psi	1,000 kPa	Connection thread - on site (flat sealing)	3/4" Male Garden Hose Thread	3/4" Male Garden Hose Thread	Throughput	2 gal/min	7.5 l/min	Length of connection hose (supplied)	approx. 5' 7"	approx. 1.7 m						
Max. temperature	150 °F	65 °C																													
Recommended flow pressure	29 psi	200 kPa																													
Min. flow pressure	4.4 psi	30 kPa																													
Max. pressure	145 psi	1,000 kPa																													
Connection thread - on site (flat sealing)	3/4" Male Garden Hose Thread	3/4" Male Garden Hose Thread																													
Throughput	2 gal/min	7.5 l/min																													
Length of connection hose (supplied)	approx. 5' 7"	approx. 1.7 m																													

(AW)	Drain Water	Drainage temperature	200 °F	93 °C
		Length of drain hose	approx. 4' 6"	approx. 1.4 m
		Drain hose, max. drainage length	approx. 13' 1"	approx. 4.0 m
		Drain pump head height from floor level, max.	approx. 3' 3"	approx. 1 m
		Drain hose delivery, max.	4.2 gal/min	16 l/min
		On-site hose connector (external diameter x length)	7/8" x 1 3/16"	22 mm x 30 mm
		It is advisable to lay the drain hose in a curve min. 600 mm above floor level to the drainage point.		
(DS)	External dispensing (optional) (note machine model)	Connection for up to two dispensing units for liquid agents on the back panel.		
	Machine feet	Height-adjustable	0-2 3/8"	0 – 60 mm
		Foot diameter	1 3/8"	35 mm
		Entry point into housing	8 M	8 M
	Heat Dissipation to Room	Heat transfer by emission	1,194 btu/h	0.35 kWh/h
		Load on removal	1,365 btu/h	0.40 kWh/h
	Machine data	Height	32 7/8"	835 mm
		Height without lid	32 1/4"	820 mm
		Width	23 5/8"	598 mm
		Depth	23 5/8"	598 mm
		Door height	24 1/2"	622 mm
		Net weight	172 lbs	78 kg
		Dynamic floor load	1,200 N	1,200 N
		Width including transport pallet	26 3/8"	670 mm
	Depth including transport pallet	29 3/8"	740 mm	
	Height including transport pallet	36 1/4"	920 mm	
	Set-up Conditions	Ambient temperature	40-105 °F	5-40 °C
		Max. humidity	80%	80%
		Max. altitude above sea level	4,921'	1,500 m
<p>It is essential to observe the installation instructions when installing the machine.</p> <p>In order to reduce the risk of steam damage, the area around the machine should be limited to furniture and fittings that are designed for use in commercial environments.</p> <p>Installation should only be performed by Miele Service or authorized installers in accordance with valid regulations, relevant standards and health and safety codes!</p> <p>Subject to change!</p>				

Caractéristiques techniques

PG8591 Laveur-désinfecteur
PG8593 Laveur de verrerie laboratoire

Miele
PROFESSIONAL

PG 8591 - 8593







Légende:



Signification des symboles entourés d'un cercle continu.
Raccordement nécessaire.







Signification des symboles entourés d'un cercle discontinu. Raccordement optionnel ou en fonction de la machine.

	Raccordement électrique (PG8591)	Tension (à la livraison) Puissance de raccordement Fusible Câble d'alimentation, section minimum Longueur du câble de raccordement (UL 921) avec fiche Fiche	2 AC 208V 60 Hz 6.2 kW 2 x 30 A 3 x AWG 10 Env. 5'9" NEMA L6-30	2 AC 208V 60 Hz 6.2 kW 2 x 30 A 3 x 5.2 mm ² Env. 1.8 m NEMA L6-30
	Raccordement électrique (PG8591)	Tension (commutable) Puissance de raccordement Fusible Câble d'alimentation, section minimum Longueur du câble de raccordement (UL 921) Fiche	3 AC 208V 60 Hz 6.2 kW 3 x 20 A 4 x AWG 12 Env. 5'9" NEMA L15-20	3 AC 208V 60 Hz 6.2 kW 3 x 20 A 4 x 3.3 mm ² Env. 1.8 m NEMA L15-20
	Raccordement électrique (240V Option PG8591)	Tension (à la livraison) Puissance de raccordement Fusible Câble d'alimentation, section minimum Longueur du câble de raccordement (UL 921) avec fiche Fiche	2 AC 240V 60 Hz 6.2 kW 2 x 30 A 3 x AWG 10 Env. 5'9" NEMA L6-30	2 AC 240V 60 Hz 6.2 kW 2 x 30 A 3 x 5.2 mm ² Env. 1.8 m NEMA L6-30
	Raccordement électrique (240V Option PG8591)	Tension (commutable) Puissance de raccordement Fusible Câble d'alimentation, section minimum Longueur du câble de raccordement (UL 921) Fiche	3 AC 240V 60 Hz 6.2 kW 3 x 20 A 4 x AWG 12 Env. 5'9" NEMA L15-20	3 AC 240V 60 Hz 6.2 kW 3 x 20 A 4 x 3.3 mm ² Env. 1.8 m NEMA L15-20
	Raccordement électrique (PG8593)	Tension (à la livraison) Puissance de raccordement Fusible Câble d'alimentation, section minimum Longueur du câble de raccordement (UL 921) avec fiche Fiche	3 AC 208V 60 Hz 6.2 kW 3 x 20 A 4 x AWG 12 Env. 5'9" NEMA L15-20	3 AC 208V 60 Hz 6.2 kW 3 x 20 A 4 x 3.3 mm ² Env. 1.8 m NEMA L15-20
	Raccordement électrique (PG8593)	Tension (commutable) Puissance de raccordement Fusible Câble d'alimentation, section minimum Longueur du câble de raccordement (UL 921) Fiche	2 AC 208V 60 Hz 6.2 kW 2 x 30 A 3 x AWG 10 Env. 5'9" NEMA L6-30	2 AC 208V 60 Hz 6.2 kW 2 x 30 A 3 x 5.2 mm ² Env. 1.8 m NEMA L6-30

L'appareil est fourni avec un câble de raccordement et une fiche. La prise doit être accessible après l'installation de l'appareil. En cas de raccordement fixe de l'appareil, il faut prévoir un interrupteur principal équipé d'un dispositif de disjonction phases et neutre et une ouverture de contact d'au moins 3 mm et doit pouvoir être fermé dans la position zéro.

Conformément aux prescriptions nationales et internationales, une liaison équipotentielle doit être établie.

Classe de protection IP21

	Liaison équipotentielle et terre	Pour effectuer le branchement d'une liaison équipotentielle, une vis de branchement est disponible à l'arrière de l'appareil. La liaison équipotentielle et la terre doivent être raccordées !																												
	Raccordement réseau/ imprimante (option)	Interfaces côté machine en option pour le transfert ou l'impression de données de cycle. Modules de communication (non fournis) : Module Ethernet ou module RS232 (Installer si nécessaire des prises au niveau de l'appareil.) Les raccordements/installations doivent être effectués conformément à IEC 60950.																												
	Eau froide	Deux raccordements à l'eau froide sont nécessaires pour les variantes de machines avec condensateur vapeur (DK). Le cas échéant, raccorder le deuxième tuyau d'eau froide avec l'élément en "Y" joint. <table border="1" data-bbox="454 795 1394 1310"> <tr> <td>Température max.</td> <td>68 °F</td> <td>20 °C</td> </tr> <tr> <td>Dureté de l'eau max. admissible</td> <td>73 gpg</td> <td>70 °dH</td> </tr> <tr> <td>Pression recommandée</td> <td>29 psi</td> <td>200 kPa</td> </tr> <tr> <td>Pression minimale</td> <td>14.5 psi</td> <td>100 kPa</td> </tr> <tr> <td>Pression maximale</td> <td>145 psi</td> <td>1,000 kPa</td> </tr> <tr> <td>Débit volumétrique</td> <td>2 gal/min</td> <td>7.5 l/min</td> </tr> <tr> <td>Raccord fileté à prévoir par l'exploitant (joint plat)</td> <td>¾ po, filage d'arrosage, mâle</td> <td>¾ po, filage d'arrosage, mâle</td> </tr> <tr> <td>Longueur tuyau de raccordement eau froide</td> <td>env. 5' 7"</td> <td>env. 1.7 m</td> </tr> <tr> <td>Longueur du tuyau de raccordement du condenseur vapeur</td> <td>env. 5' 7"</td> <td>env. 1.7 m</td> </tr> </table>		Température max.	68 °F	20 °C	Dureté de l'eau max. admissible	73 gpg	70 °dH	Pression recommandée	29 psi	200 kPa	Pression minimale	14.5 psi	100 kPa	Pression maximale	145 psi	1,000 kPa	Débit volumétrique	2 gal/min	7.5 l/min	Raccord fileté à prévoir par l'exploitant (joint plat)	¾ po, filage d'arrosage, mâle	¾ po, filage d'arrosage, mâle	Longueur tuyau de raccordement eau froide	env. 5' 7"	env. 1.7 m	Longueur du tuyau de raccordement du condenseur vapeur	env. 5' 7"	env. 1.7 m
Température max.	68 °F	20 °C																												
Dureté de l'eau max. admissible	73 gpg	70 °dH																												
Pression recommandée	29 psi	200 kPa																												
Pression minimale	14.5 psi	100 kPa																												
Pression maximale	145 psi	1,000 kPa																												
Débit volumétrique	2 gal/min	7.5 l/min																												
Raccord fileté à prévoir par l'exploitant (joint plat)	¾ po, filage d'arrosage, mâle	¾ po, filage d'arrosage, mâle																												
Longueur tuyau de raccordement eau froide	env. 5' 7"	env. 1.7 m																												
Longueur du tuyau de raccordement du condenseur vapeur	env. 5' 7"	env. 1.7 m																												
	Eau chaude	<table border="1" data-bbox="454 1310 1394 1751"> <tr> <td>Température max.</td> <td>150 °F</td> <td>65 °C</td> </tr> <tr> <td>Dureté de l'eau max. admissible</td> <td>73 gpg</td> <td>70 °dH</td> </tr> <tr> <td>Pression recommandée</td> <td>29 psi</td> <td>200 kPa</td> </tr> <tr> <td>Pression minimale</td> <td>5.8 psi</td> <td>40 kPa</td> </tr> <tr> <td>Pression maximale</td> <td>145 psi</td> <td>1,000 kPa</td> </tr> <tr> <td>Débit volumétrique</td> <td>2 gal/min</td> <td>7.5 l/min</td> </tr> <tr> <td>Raccord fileté à prévoir par l'exploitant (joint plat)</td> <td>¾ po, filage d'arrosage, mâle</td> <td>¾ po, filage d'arrosage, mâle</td> </tr> <tr> <td>Longueur tuyau de raccordement eau chaude</td> <td>env. 5' 7"</td> <td>env. 1.7 m</td> </tr> </table>		Température max.	150 °F	65 °C	Dureté de l'eau max. admissible	73 gpg	70 °dH	Pression recommandée	29 psi	200 kPa	Pression minimale	5.8 psi	40 kPa	Pression maximale	145 psi	1,000 kPa	Débit volumétrique	2 gal/min	7.5 l/min	Raccord fileté à prévoir par l'exploitant (joint plat)	¾ po, filage d'arrosage, mâle	¾ po, filage d'arrosage, mâle	Longueur tuyau de raccordement eau chaude	env. 5' 7"	env. 1.7 m			
Température max.	150 °F	65 °C																												
Dureté de l'eau max. admissible	73 gpg	70 °dH																												
Pression recommandée	29 psi	200 kPa																												
Pression minimale	5.8 psi	40 kPa																												
Pression maximale	145 psi	1,000 kPa																												
Débit volumétrique	2 gal/min	7.5 l/min																												
Raccord fileté à prévoir par l'exploitant (joint plat)	¾ po, filage d'arrosage, mâle	¾ po, filage d'arrosage, mâle																												
Longueur tuyau de raccordement eau chaude	env. 5' 7"	env. 1.7 m																												

VE	Eau déminéralisée	Température max.	150 °F	65 °C
		Pression recommandée (AD résistant à la pression)	29 psi	200 kPa
		Pression minimale	4.4 psi	30 kPa
		Pression maximale (AD résistant à la pression)	145 psi	1,000 kPa
		Débit volumétrique	¾ po, filage d'arrosage, mâle	¾ po, filage d'arrosage, mâle
		Raccord fileté à prévoir par l'exploitant (joint plat)	2 gal/min	7.5 l/min
		Longueur tuyau de raccordement eau déminéralisée	env. 5' 7"	env. 1.7 m
AW	Vidange	Température de l'eau de vidange	200 °F	93 °C
		Longueur du tuyau de vidange	env. 4' 6"	env. 1.4 m
		Longueur max. de la rallonge du tuyau de vidange	env. 13' 1"	env. 4.0 m
		Hauteur de refoulement de la pompe de vidange à partir du rebord inférieur de l'appareil (max.)	env. 3' 3"	env. 1 m
		Débit volumétrique temporaire max. de la vidange	4.2 gal/min	16 l/min
		Obtrateur à prévoir par l'utilisateur par tuyau de vidange (da x l)	7/8" x 1 3/16"	22 mm x 30 mm
		Il est conseillé de guider dans la vidange, le tuyau de vidange dans un coude de 600 mm min. au-dessus du bord supérieur du sol fini.		
DS	Dosage externe (en option) (Respecter le modèle de l'appareil)	Raccordement jusqu'à deux dispositifs de dosage pour produits liquides sur la paroi arrière.		
	Socle	Hauteur réglable	0-2 3/8"	0 – 60 mm
		Diamètre du socle	1 3/8"	35 mm
		Emplacement pour les pieds de l'appareil	8 M	8 M
	Emission de chaleur dans la pièce d'installation	Emission de chaleur par rayonnement	1,194 btu/h	0.35 kWh/h
		Emission de chaleur par produit de rinçage lors de prélèvement	1,365 btu/h	0.40 kWh/h
	Caractéristiques	Hauteur avec couvercle	32 7/8"	835 mm
		Hauteur d'encastrement	32 1/4"	820 mm
		Largeur	23 5/8"	598 mm
		Profondeur	23 5/8"	598 mm
		Hauteur de la porte	24 1/2"	622 mm
		Poids net	172 lbs	78 kg
		Charge au sol en fonctionnement	1,200 N	1,200 N
		Largeur de chargement minimale de l'appareil avec palette de transport	26 3/8"	670 mm
		Profondeur de chargement minimale de l'appareil avec palette de transport	29 3/8"	740 mm
	Hauteur de chargement minimale de l'appareil avec palette de transport	36 1/4"	920 mm	

	Conditions d'installation	Température ambiante	40-105 °F	5-40 °C
		Humidité relative de l'air max	80%	80%
		Hauteur d'installation max. au-dessus du niveau de la mer (NN)	4,921'	1,500 m
<p>Respectez impérativement les instructions de montage lors de l'installation de l'appareil.</p> <p>Il est conseillé de n'utiliser que des meubles adaptés à un usage industriel à proximité de l'appareil afin d'éviter les dommages éventuels provoqués par la condensation.</p> <p>L'installation doit exclusivement être effectuée par le Service Miele ou des installateurs agréés, conformément aux prescriptions et aux règlements et aux règlements de prévention des accidents en vigueur.</p> <p>Sous réserve de modifications !</p>				

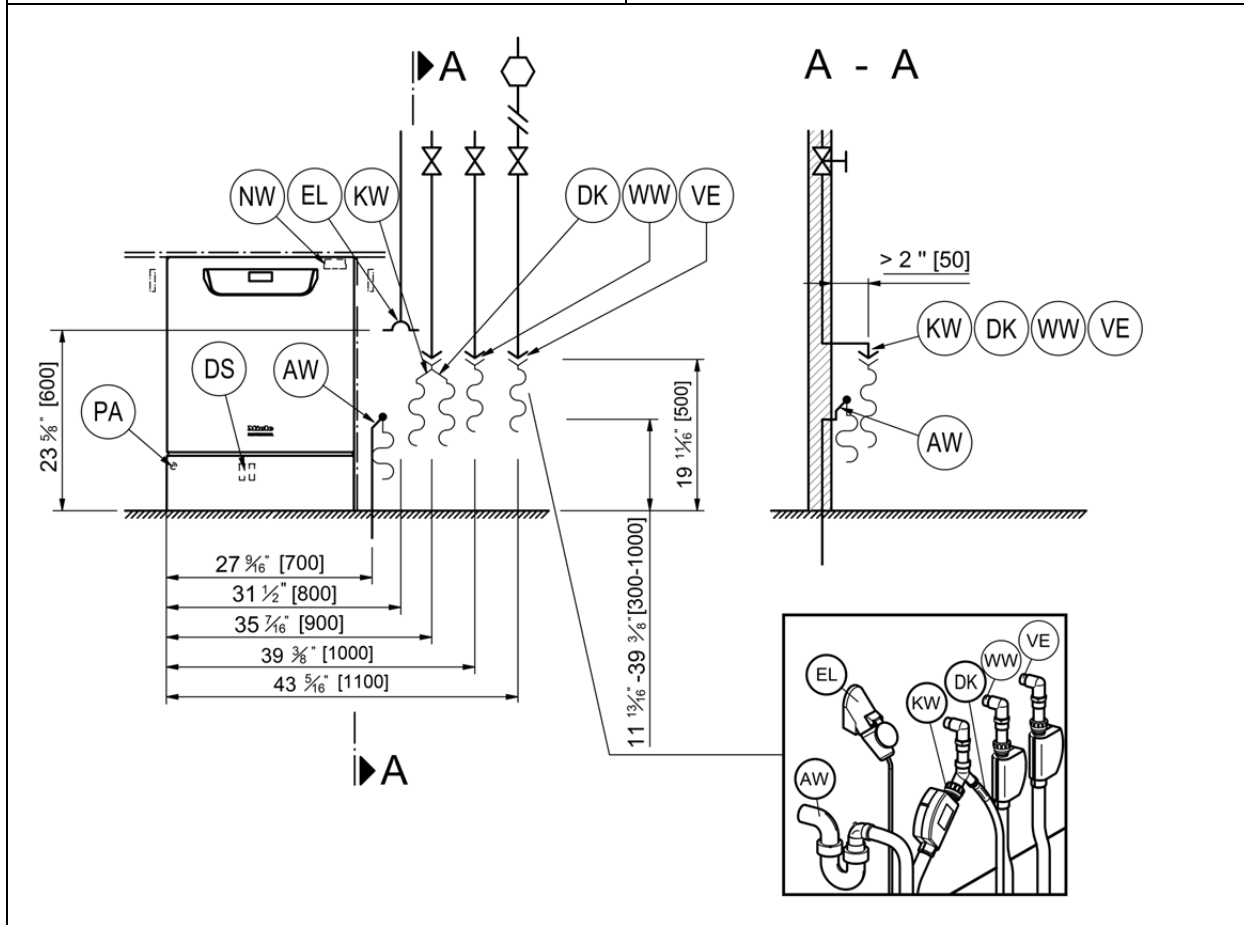
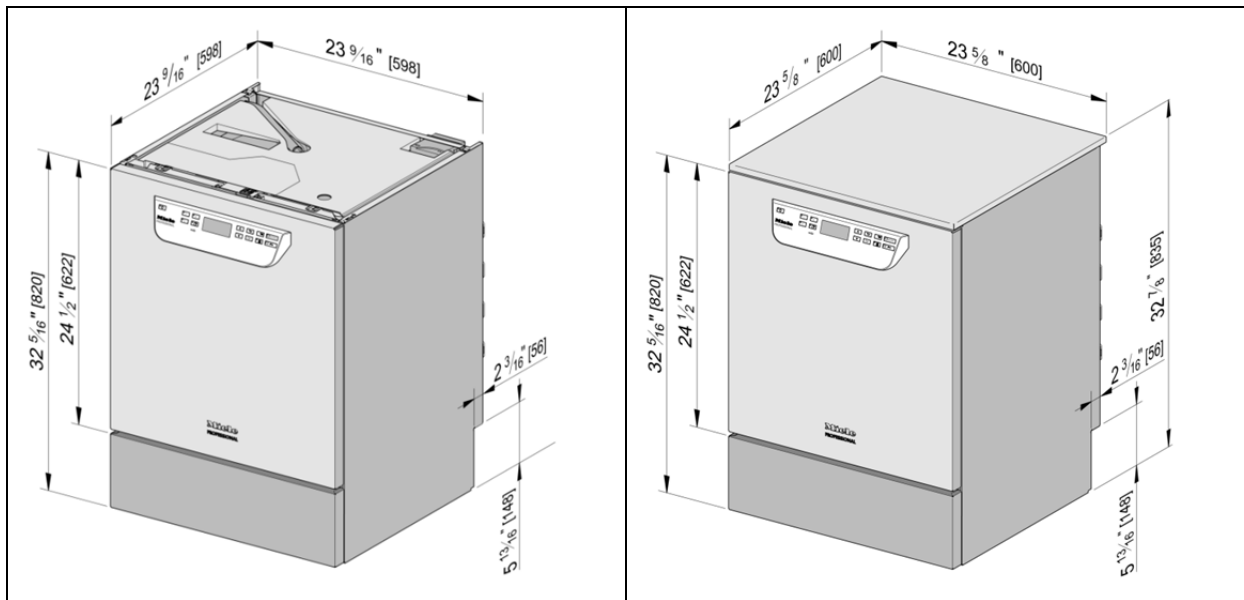

AW	Drain water	NW	Network and printer connection
DK	Cold water connection, steam condenser	PA	Equipotential bonding
DS	External dispensing system connection	VE	Demineralized water connection
EL	Electrical connection	WW	Hot water connection
KW	Cold water connection		

AW	Vidange	NW	Raccordement réseau et à une imprimante (en option)
DK	Raccordement eau froide pour condensateur	PA	Liaison équipotentielle
DS	Raccordement Dosage externe (en option)	VE	Raccordement à l'eau déminéralisée
EL	Branchement électrique	WW	Raccordement à l'eau chaude
KW	Raccordement eau froide		

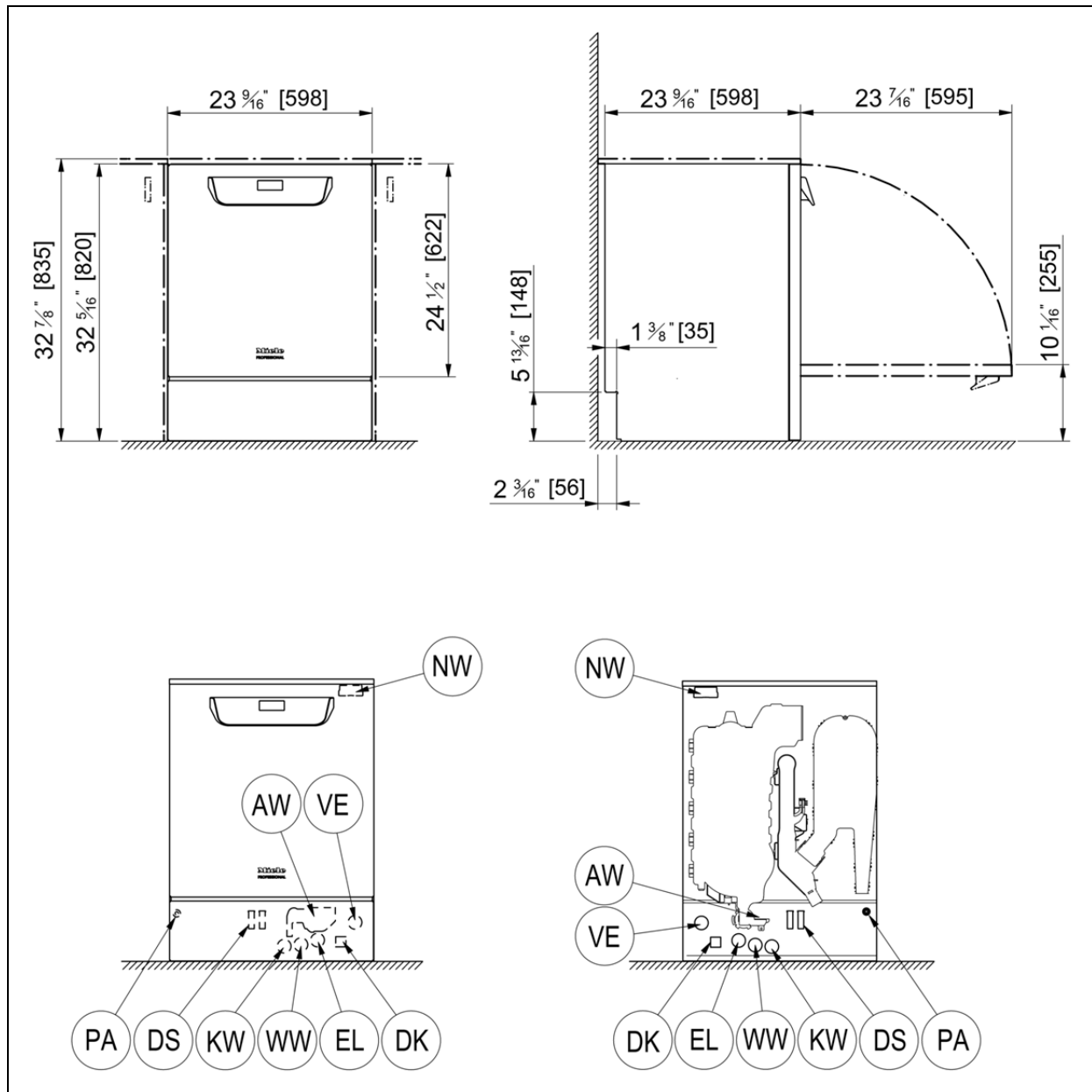

AW	Drain water	NW	Network and printer connection
DK	Cold water connection, steam condenser	PA	Equipotential bonding
DS	External dosing system connection	VE	Demineralized water connection
EL	Electrical connection	WW	Hot water connection
KW	Cold water connection		

AW	Vidange	NW	Raccordement réseau et à une imprimante (en option)
DK	Raccordement eau froide pour condensateur	PA	Liaison équipotentielle
DS	Raccordement Dosage externe (en option)	VE	Raccordement à l'eau déminéralisée
EL	Branchement électrique	WW	Raccordement à l'eau chaude
KW	Raccordement eau froide		