

Installationsplan / Installation plan

Installatietekening
Plan d'installation
Pianta di installazione

Plano de instalación
Plano de instalação
Σχέδιο εγκατάστασης

Asennusohje
Installasjonsplan
Installationsplan

GB

PG 8536

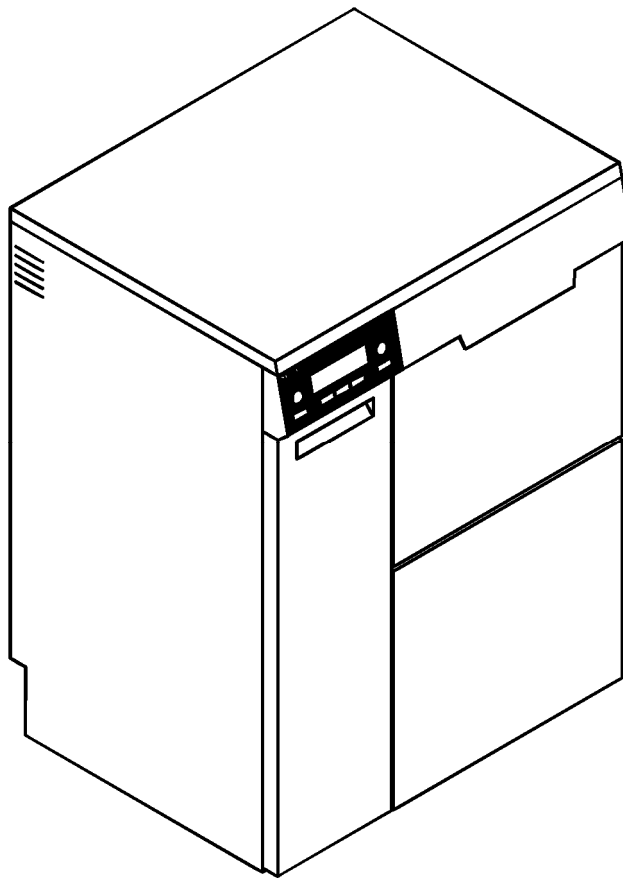

Materialnummer	/	Mat. no.	7880430
Änderungsstand	/	Version	00
Änderungsnr.	/	Alteration number	A012718
Datum Zeichnung	/	Drawing Date	01.09.2009
Datum Legende	/	Legend Date	01.09.2009
Freigabe	/	Approval	Name: Götza

Technical datasheet



Compact disinfector

PG 8536

Legend:



Abbreviations in bold type:
Connection required



Abbreviations in circle with dashes:
Connection optional or required depending on model version



GB

The unit should only be transported using a palletiser or fork-lift truck if securely positioned on Miele transportation pallet.

EL	Electrical connection	1. Voltage Rated load Fuse rating Connection cable, min. cross-section Length of supply lead (H05(07)RN-F) with plug		V/Hz kW A mm ² m	3N AC 400/50 10,2 3 × 16 5 × 2,5 1,5
	Country variations:				
	B F I N	2. Voltage (as supplied) Rated load Fuse rating Connection cable, min. cross-section Length of supply lead (H05(07)RN-F) without plug		V/Hz kW A mm ² m	3N AC 400/50 7,8 3 × 16 5 × 2,5 1,7
		Voltage Rated load Fuse rating Connection cable, min. cross-section Length of supply lead (H05(07)RN-F) without plug	Convertible	V/Hz kW A mm ² m	3 AC 230/50 7,8 3 × 20 5 × 2,5 1,7
	B F I N	3. Voltage (as supplied) Rated load Fuse rating Connection cable, min. cross-section Length of supply lead (H05(07)RN-F) without plug		V/Hz kW A mm ² m	3 AC 230/50 7,8 3 × 20 5 × 2,5 1,7
	Voltage Rated load Fuse rating Connection cable, min. cross-section Length of supply lead (H05(07)RN-F) without plug	Convertible	V/Hz kW A mm ² m	3N AC 400/50 7,8 3 × 16 5 × 2,5 1,7	
	USA CDN	4. Voltage Rated load Fuse rating Connection cable, min. cross-section Length of supply lead without plug		V/Hz kW A AWG m	3 AC 208/60 6,6 3 × 20 4 × 12 1,9
	JP	5. Voltage Rated load Fuse rating Connection cable, min. cross-section Length of supply lead (H05(07)RN-F) without plug		V/Hz kW A mm ² m	3 AC 200/50 6,2 3 × 20 5 × 2,5 2,3

<p style="text-align: center;">(JP)</p>	<p>6. Voltage Rated load Fuse rating Connection cable, min. cross-section Length of supply lead (H05(07)RN-F) without plug</p>		<p>V/Hz kW A mm² m</p>	<p>3 AC 200/60 6.2 3 × 20 5 × 2,5 2.3</p>
<p style="text-align: center;">(EXP)</p>	<p>7. Voltage (as supplied) Rated load Fuse rating Connection cable, min. cross-section Length of supply lead (H05(07)RN-F) without plug</p>		<p>V/Hz kW A mm² m</p>	<p>3N AC 380/60 7.2 3 × 16 5 × 2.5 2.3</p>
	<p>Voltage Rated load Fuse rating Connection cable, min. cross-section Length of supply lead (H05(07)RN-F) without plug</p>	Convertible	<p>V/Hz kW A mm² m</p>	<p>3 AC 220/60 7.2 3 × 20 5 × 2.5 2.3</p>
<p style="text-align: center;">(EXP)</p>	<p>8. Voltage (as supplied) Rated load Fuse rating Connection cable, min. cross-section Length of supply lead (H05(07)RN-F) without plug</p>		<p>V/Hz kW A mm² m</p>	<p>3 AC 220/60 7.2 3 × 20 5 × 2.5 2.3</p>
	<p>Voltage Rated load Fuse rating Connection cable, min. cross-section Length of supply lead (H05(07)RN-F) without plug</p>	Convertible	<p>V/Hz kW A mm² m</p>	<p>3N AC 380/60 7.2 3 × 16 5 × 2.5 2.3</p>
	<p>Plug and socket connection recommended to facilitate accessibility for electrical safety tests. Socket must be accessible after installation. In the case of hard-wired connections, an all-pole mains switch must be provided. Contact gap: 3 mm. In the case of multiple units, main switches should be properly labelled. Protect supply lead against damage through heat. Installation must be CAT II grade. Max. permissible supply fluctuation +/- 10% Connection to electrical supply should be in accordance with valid regulations and safety standards.</p>			
<p style="text-align: center;">(PA)</p>	<p>Equipotential bonding and protective earth conductor</p> <p>Pin with external thread, washer and nut provided with machine, size</p> <p>Connect equipotential bonding and protective earth conductor!</p>		<p>M</p>	<p>8x1.25</p>
<p style="text-align: center;">(NW)</p>	<p>Network/ printer connection</p> <p>The following machine interfaces are available for the transmission and printing of process data.</p> <p>Ethernet interface: A RJ45 plug is available on the rear of the compact disinfectant. Install RJ45 socket in vicinity of machine. Cable supplied on site.</p> <p>Connections/installation must comply with IEC 60950.</p>			

(AM)	(Optional) Connection module Output signals	Potential-free contacts (NO contacts) <input type="checkbox"/> A maximum of 9 contacts are available <input type="checkbox"/> , Possible assignment:	Contact load Max.:	
	TA OPERATION	Contact closed during drying block	V/A/Hz	200-240/1/50-60
	PRG RUNNING	Contact closed during washing, drying and cool-down	V/A/Hz	200-240/1/50-60
	OPERATION	Contact closed while machine is running	V/A/Hz	200-240/1/50-60
	FAULT	Contact closed when fault occurs	V/A/Hz	200-240/1/50-60
	PRG END	Contact closed between end of programme and door opening	V/A/Hz	200-240/1/50-60
	PAUSE w. WASH	Contact closed during 'Pause with wash action' stage	V/A/Hz	200-240/1/50-60
	DRAINAGE	Contact closed during drainage	V/A/Hz	200-240/1/50-60
	User-defined	Contact activated during drainage if plug ST 6.1 to ST 6.5 is programmed in 'External contact - Drainage' block.	V/A/Hz	200-240/1/50-60
	COLD	Contact closed during cold water intake	V/A/Hz	200-240/1/50-60
	HOT	Contact closed during hot water intake	V/A/Hz	200-240/1/50-60
	AD	Contact closed during de-mineralised water intake	V/A/Hz	200-240/1/50-60
	Cold delayed	Output according to parameters	V/A/Hz	200-240/1/50-60
	Hot delayed	Delay switch-off valve:	V/A/Hz	200-240/1/50-60
	De-min. delayed	a. Delayed (start of water intake) b. Brought forwards (end of water intake)	V/A/Hz V/A/Hz	200-240/1/50-60 200-240/1/50-60
DOS1- EXTERNAL	Control signal for external dispenser pump 1	V/A/Hz	200-240/1/50-60	
DOS2-EXT	Control signal for external dispenser pump 2	V/A/Hz	200-240/1/50-60	
DOS3-EXT	Control signal for external dispenser pump 3	V/A/Hz	200-240/1/50-60	
DOS4-EXT	Control signal for external dispenser pump 4	V/A/Hz	200-240/1/50-60	
DOS5-EXT	Control signal for external dispenser pump 5	V/A/Hz	200-240/1/50-60	
DOS6-EXT	Control signal for external dispenser pump 6	V/A/Hz	200-240/1/50-60	
DOS7-EXT	Control signal for external dispenser pump 7	V/A/Hz	200-240/1/50-60	
DOS8-EXT	Control signal for external dispenser pump 8	V/A/Hz	200-240/1/50-60	
DOS9-EXT	Control signal for external dispenser pump 9	V/A/Hz	200-240/1/50-60	
Information DOS 1	Contact activated when appropriate pump is activated during the programme	V/A/Hz	200-240/1/50-60	
Information DOS 2	Contact activated when appropriate pump is activated during the programme	V/A/Hz	200-240/1/50-60	
Information DOS 3	Contact activated when appropriate pump is activated during the programme	V/A/Hz	200-240/1/50-60	
Information DOS 4	Contact activated when appropriate pump is activated during the programme	V/A/Hz	200-240/1/50-60	
Information DOS 5	Contact activated when appropriate pump is activated during the programme	V/A/Hz	200-240/1/50-60	
Connection module <input type="checkbox"/> Input signals		Control voltage		
SLA HZG	Peak-load negotiation - Heating	V/Hz	200-240/50-60	
DOS-EXT	Fill level of external dispenser canister	V/Hz	200-240/50-60	
MEDIUM	Medium dispensing active, signal for flow and volume control	V/Hz	200-240/50-60	
EXT TEXT	External text	V/Hz	200-240/50-60	
(KW)	Cold water	Two cold water connections required on models with steam condenser (DK). Second cold water inlet hose can be connected using Y-piece supplied.		
		Max. temperature	°C	20
		Max. water hardness	°dH	60
		Min. flow pressure	kPa	250
		Max. pressure	kPa	1000
		Throughput	l/min	10
		On-site connection thread according to DIN 44 991	Inch	3/4" external thread (USA: 11.5 NH)
		Length of connection hose (supplied)	mm	1500
		Length of steam condenser inlet hose (supplied with DK version)	mm	1500
		DVGW certification Direct connection without fuse box permissible.		

	Hot water	Max. temperature Max. water hardness Min. flow pressure Max. pressure Throughput On-site connection thread according to DIN 44 991 Length of connection hose (supplied) DVGW certification Direct connection without fuse box permissible.	°C °dH kPa kPa l/min Inch mm	70 60 250 1000 10 3/4" external thread (USA: 11.5 NH) 1500
	De-min. water	Standard version: Min. flow pressure Min. flow pressure with extended fill time Max. pressure Throughput Connection thread (on site) Length of connection hose (supplied) Version with demineralised water feed pump (ADP): Min. flow pressure Max. pressure Machine-side connection (ext. dia. × wall thickness) Hose from container to machine to be provided on site	kPa kPa kPa l/min Inch mm kPa kPa mm	250 100 1000 10 3/4 external (USA: 11.5 NH) 1500 5 30 6 × 30
	Effluent	Two drain hoses supply with DK version. Drain hose (Int. dia. × wall thickness × l) Drain pump (supplied) Steam condenser (supplied with DK version) Drain pump head height from floor level, max. Max. transient throughput – Drain hose On-site hose connector (Ext. dia. × l) Drain pump Steam condenser (DK version)	mm mm m l/min mm mm	22 × 6 × 1500 22 × 6 × 1500 1.0 50 22 × 30 22 × 30
	Machine data	Height incl. lid Width Depth Net weight Dynamic floor load Min. transport width incl. pallet Min. transport height incl. pallet	mm mm mm kg N mm mm	1175 900 700 180 3000 800 1400
Installation should only be carried out by authorised fitters in accordance with valid regulations! Observe installation instructions when installing machine! Only commercial-grade cabinets should be used in the vicinity of a washer-disinfector to avoid any damage caused by condensate. Observe installation instructions when installing machine! All rights reserved! Measurements in mm				

Änderungsnr.	Datum	Bezeichnung:
Axxxxxx	xx.xx.xxxx	Einführung

