

Installation plan:

PG 8504

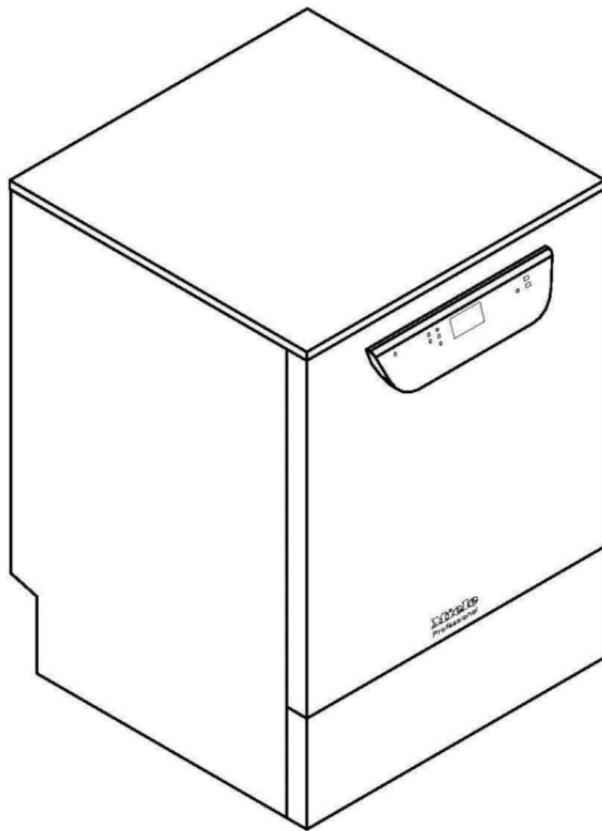

Mat. no.
Version



10 344 110
00
US

Legend:

(EL) Circled, bold-type abbreviations:
Connection required

(DS) Abbreviations surrounded by broken circle:
Connection optional or required, depending on model

(EL)	Electrical connection	Voltage (default) Rated load Fuse rating Minimum cross-section Length of electrical cord (UL 921) with plug Plug type	3 AC 208V 60 Hz 6.1 kW 3 pole 20 Amp 4 x AWG 12 approx. 5' 9" NEMA L15-20	3 AC 208V 60 Hz 6.1 kW 3 pole 20 Amp 4 x 3.3 mm ² approx. 1.8 m NEMA L15-20
(EL)	Electrical connection	Voltage (convertible) Rated load Fuse rating Minimum cross-section Length of electrical cord (UL 921) with plug Plug type	2 AC 208V 60 Hz 6.1 kW 2 pole 30 Amp 3 x AWG 10 approx. 5' 9" NEMA L6-30	2 AC 208V 60 Hz 6.1 kW 2 pole 30 Amp 3 x 5.2 mm ² approx. 1.8 m NEMA L6-30
<p>Connection to the electrical supply must be carried out in accordance with local and national safety regulations. The power cord must be protected from the risk of thermal damage.</p> <p>It is recommended to make an electrical connection via a plug and socket so that electrical safety checks can be carried out easily. The socket must be accessible after machine installation.</p> <p>For hard-wired machines, a main switch must be provided on site, which must completely isolate the machine from the power supply with a contact gap of at least 1/8" (3 mm).</p> <p>The plug and socket as well as the main switch must be easily accessible after the machine has been installed.</p>				
(PA)	Equipotential bonding and grounding	<p>For added safety the machine should be protected with a residual current device with a trip current of 30 mA.</p> <p>If necessary, an equipotential bond with good contact connection must be provided in accordance with all appropriate national and local regulations.</p> <p>Equipotential bonding and grounding must be completed before the machine is commissioned.</p> <p>There is a screw connection point at the back of the washer-disinfector, to which equipotential bonding can be connected.</p>		

	Cold Water Connection	Max. temperature	68 °F	20 °C
		Max. water hardness	73 gpg	70 °dH
		Recommended flow pressure	29 psi	200 kPa
		Min. flow pressure with extended water intake	14.5 psi	100 kPa
		Max. pressure	145 psi	1,000 kPa
		Throughput	2 gal/min	7.5 l/min
		Connection thread - on site (flat sealing)	3/4" Male Garden Hose Thread	3/4" Male Garden Hose Thread
		Length of connection hose (supplied)	approx. 5' 7"	approx. 1.7 m
	Hot Water Connection	Max. temperature	150 °F	65 °C
		Max. water hardness	73 gpg	70 °dH
		Recommended flow pressure	29 psi	200 kPa
		Min. flow pressure with extended water intake	5.8 psi	40 kPa
		Max. pressure	145 psi	1,000 kPa
		Throughput	2 gal/min	7.5 l/min
		Connection thread - on site (flat sealing)	3/4" Male Garden Hose Thread	3/4" Male Garden Hose Thread
		Length of connection hose (supplied)	approx. 5' 7"	approx. 1.7 m
	Demineralized water	Max. temperature	150 °F	65 °C
		Recommended flow pressure	29 psi	200 kPa
		Min. flow pressure with extended water intake	4.4 psi	30 kPa
		Max. pressure	145 psi	1,000 kPa
		Connection thread - on site (flat sealing)	3/4" Male Garden Hose Thread	3/4" Male Garden Hose Thread
		Throughput	2 gal/min	7.5 l/min
		Length of connection hose (supplied)	approx. 5' 7"	approx. 1.7 m
		Requirements for unpressurized demineralized water system:		
	Minimum flow pressure (DI unpressurized)	1.3 psi	8.5 kPa	
	Maximum pressure (DI unpressurized)	8.7 psi	60 kPa	
	Machine connection nipple (outer dia. x l)	1/4" x 3/16"	6 mm x 30 mm	
Hose from supply container to machine to be installed on site.				

(AW)	Drain Water	Drainage temperature	200 °F	93 °C
		Length of drain hose	approx. 4' 6"	approx. 1.4 m
		Drain hose, max. drainage length	approx. 13' 1"	approx. 4.0 m
		Drain pump head height from floor level, max.	approx. 3' 3"	approx. 1 m
		Drain hose delivery, max.	4.2 gal/min	16 l/min
		On-site hose connector (external diameter x length)	7/8" x 1 3/16"	22 mm x 30 mm
It is advisable to lay the drain hose in a curve min. 23 5/8" (600 mm) above floor level to the drainage point.				
(DS)	External dispensing (optional)	Connection for one dispensing unit for liquid agents on the back panel.		
	Machine feet	Height-adjustable	0 - 2 3/8"	0 - 60 mm
		Foot diameter	1 3/8"	35 mm
		Entry point into housing	8 M	8 M
	Heat Dissipation to Room	Heat transfer by emission	1,194 btu/h	0.35 kWh/h
		Load on removal	1,365 btu/h	0.40 kWh/h
	Machine data	Height	32 7/8"	835 mm
		Height without lid	32 5/16"	820 mm
		Width	23 5/8"	600 mm
		Width without lid	23 9/16"	598 mm
		Depth	23 5/8"	600 mm
		Depth without lid	23 9/16"	598 mm
		Door height	24 1/2"	622 mm
		Net weight	159 lbs	72 kg
		Dynamic floor load	1,200 N	1,200 N
		Width including transport pallet	26 3/8"	670 mm
		Depth including transport pallet	29 3/8"	740 mm
		Height including transport pallet	36 1/4"	920 mm
		Sound emissions in dB (A), Sound pressure LpA, washing and drying	< 70 dB	< 70 dB
	Set-up Conditions	Ambient temperature	40-105 °F	5-40 °C
		Max. humidity	80%	80%
		Rel. humidity, declining proportionally up to 104°F (40°C)	50%	50%
		Max. altitude above sea level	4,921'	1,500 m
Please read and observe the instructions in the operating instruction manual and the service documents regarding installation and setting up of this medical washer/disinfector.				
Installation should only be carried out by authorized installers in accordance with valid regulations, relevant standards and health and safety codes. The machine must be commissioned and operators trained in its use by Miele Service or by an approved Miele Service Partner only.				
Condensate can build up in the area surrounding the machine. Any cabinetry and fixtures in the room must be suitable. If the machine is installed under a countertop (built-under model), a stainless steel panel must be installed above the door opening to protect the countertop from moisture damage. A suitable stainless steel cover plate is available to order from Miele.				

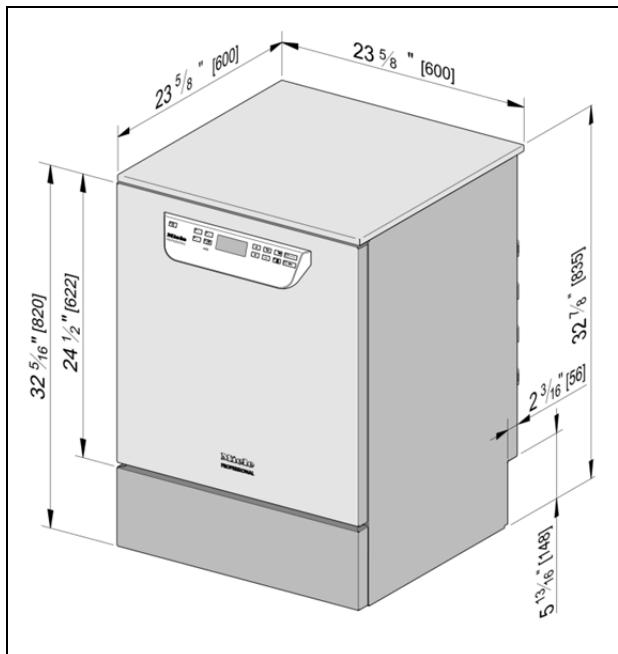

Machine with lid (standard)

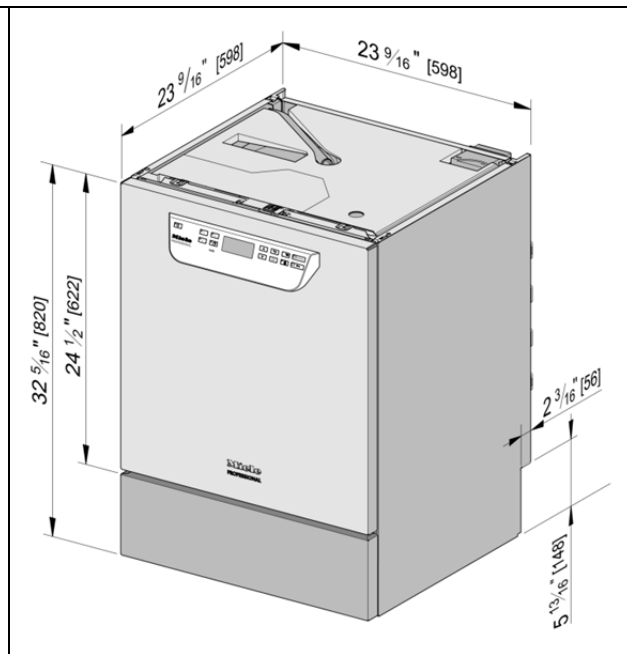

Machine without lid

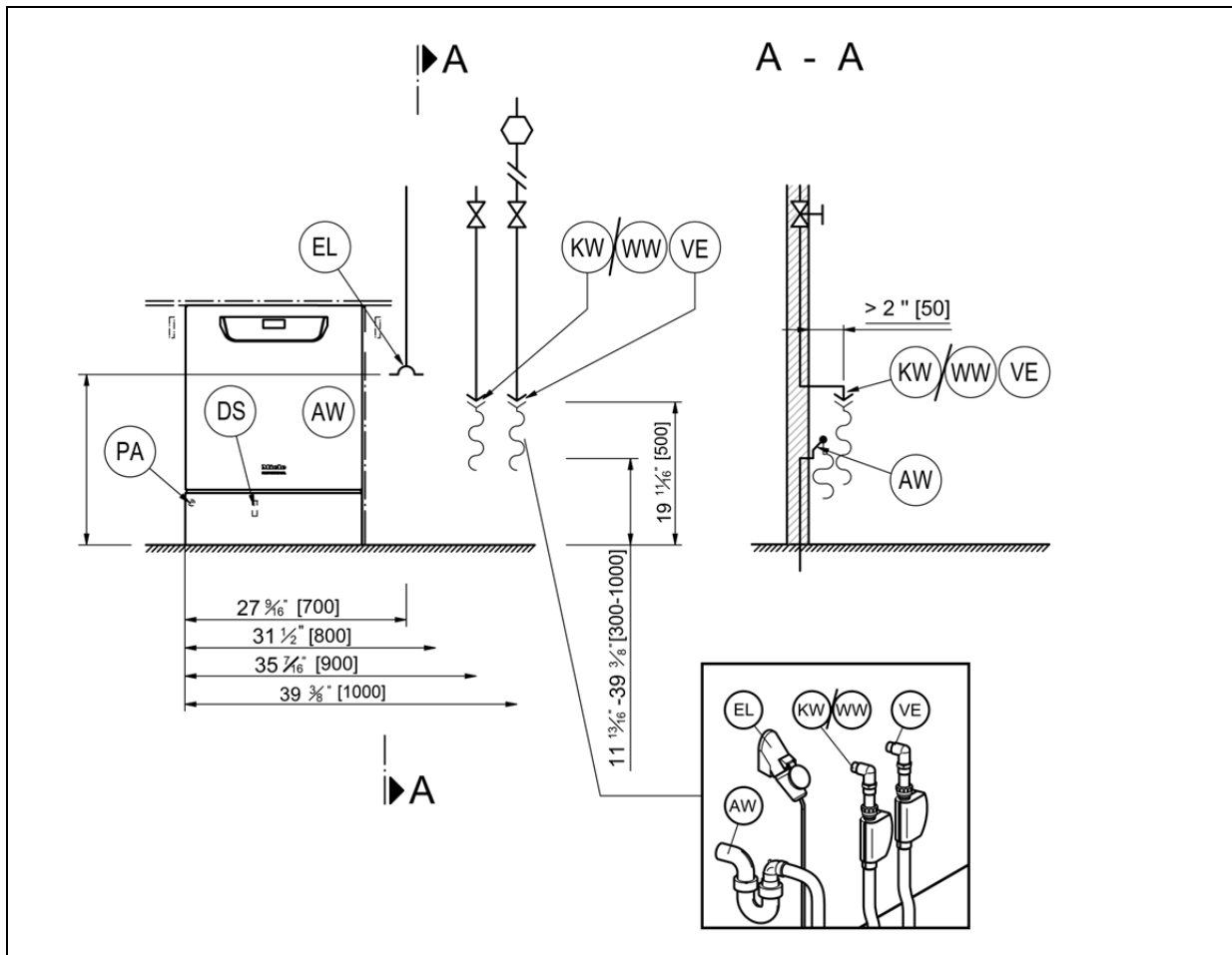

AW	Drain water	PA	Equipotential bonding
DS	External dispensing system connection	VE	Demineralized water connection
EL	Electrical connection	WW	Hot water connection
KW	Cold water connection		

Machine shown without lid

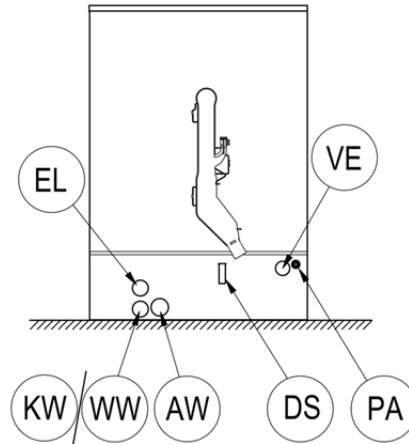
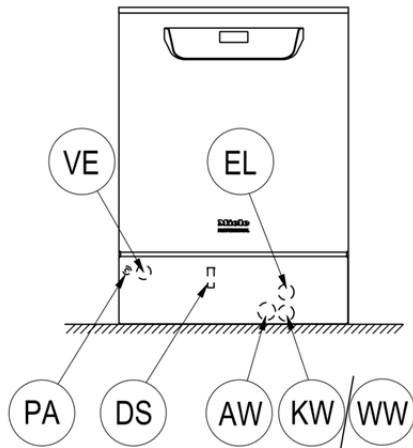
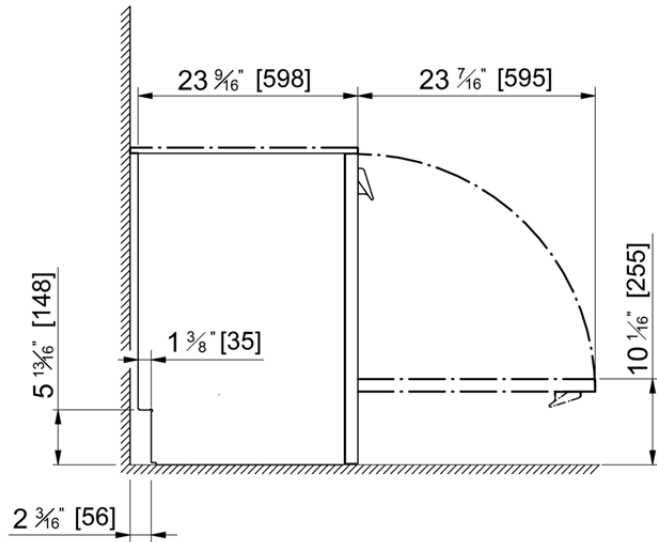
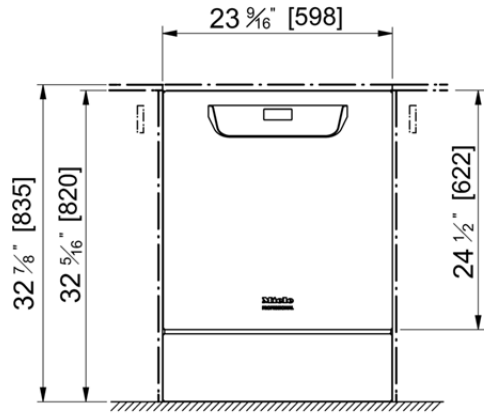

AW	Drain water	PA	Equipotential bonding
DS	External dispensing system connection	VE	Demineralized water connection
EL	Electrical connection	WW	Hot water connection
KW	Cold water connection		