

Operating and installation instructions Refrigerator



It is **essential** to read these operating and installation instructions before installing and using the appliance. This prevents both personal injury and damage to the appliance.

Contents

Warning and Safety instructions	4
Caring for the environment	12
Saving energy	13
Guide to the appliance	15
Control panel.....	15
Accessories	17
Accessories supplied	17
Optional accessories.....	17
Switching on and off	19
Before using for the first time.....	19
Switching off for longer periods of time.....	20
The correct temperature	21
... in the refrigerator section	21
Temperature display.....	21
Setting the temperature	21
Using SuperCool	22
SuperCool.....	22
Door alarm	23
Switching the door alarm off early	23
Selecting further settings	24
Settings mode.....	24
Switching the safety lock on/off	24
Storing food in the refrigerator section	25
Different storage zones	25
Food which is not suitable for storage in the refrigerator	25
Notes on buying food.....	25
Storing food correctly	25
Adjusting the interior fittings	27
Adjusting the door shelf/bottle shelf.....	27
Moving the adjustable shelves.....	27
Adjusting the bottle holder	27
Moving the charcoal filters.....	28
Defrosting	29
Cleaning and care	30
Cleaning agents	30
Preparing the appliance for cleaning	31
Cleaning the interior and accessories	32
Cleaning the door seals.....	33

Cleaning the ventilation gaps	33
Starting up the appliance after cleaning	33
Replacing the charcoal filters	34
Problem solving guide	35
Noises	40
Service	41
Contact in case of fault.....	41
Warranty	41
Electrical connection	42
Installation advice	43
Location	43
Climate range	43
Ventilation.....	44
Furniture door	44
Gap size.....	44
Weight of the furniture door.....	45
Before installing the appliance	46
Building-in dimensions	46
Changing the door hinging	47
Changing the door hinging	47
Adjusting the door hinge	49
Adjusting the spring force of the appliance door.....	49
Limiting the opening angle of the door.....	49
Installing the appliance	50
To install the appliance, you will need the following tools:	50
Parts required for installation	50
Preparing the appliance.....	50
Pushing the appliance into its niche.....	51
Aligning the appliance.....	53
Fitting a continuous furniture plinth panel.....	54
Securing the appliance in the niche.....	54
Fitting a furniture door	55

Warning and Safety instructions

This refrigeration appliance complies with current local and national safety requirements. However, inappropriate use can lead to personal injury and damage to property.

Please read the operating and installation instructions carefully before using the refrigeration appliance for the first time. They contain important information on safety, installation, use and maintenance of the appliance. This is to protect yourself from injury and from damaging your refrigeration appliance.

In accordance with standard IEC 60335-1, Miele expressly and strongly advises that you read and follow all information provided concerning the installation of the refrigeration appliance, as well as safety notes and warnings.

Miele cannot be held liable for injury or damage caused by non-compliance with these instructions.

Keep these instructions in a safe place and pass them on to any future owner.

Correct application

► This appliance is designed for domestic use and for use in similar environments by guests in hotel or motel rooms, bed & breakfasts and other typical living quarters. This does not include common/shared facilities or commercial facilities within hotels, motels or bed & breakfasts.

This appliance is not suitable for outdoor use.

► The refrigeration appliance is intended exclusively for domestic use for cooling and storing food and drink.

The refrigeration appliance is not suitable for freezing food.

Any other usage is not permitted.

► This appliance is not suitable for storing and keeping cool medicines, blood plasma, laboratory preparations or similar substances or products. Incorrect use of the appliance for such purposes may cause deterioration of the items stored.

The appliance is also not suitable for use in areas where there is a risk of explosion.

Miele cannot be held liable for damage resulting from incorrect or improper use or operation of the appliance.

Warning and Safety instructions

▶ This appliance is not intended for use by persons (including children) with reduced physical, sensory or mental capabilities or lack of experience and knowledge, unless they have been given supervision and instruction concerning its use by a person responsible for their safety.

They may only use the appliance unsupervised if its operation has been clearly explained to them and they are able to use it safely and are able to understand and recognise the possible dangers caused by incorrect operation.

Safety with children

▶ Young children must not be allowed to use this appliance.

▶ Older children may only use the appliance when its operation has been clearly explained to them and they are able to use it safely, recognising the dangers of misuse.

▶ Cleaning work may only be carried out by older children under the supervision of an adult.

▶ Please supervise children in the vicinity of the appliance and do not let them play with it.

▶ Danger of suffocation! Children may be able to wrap themselves in packing material (e.g. foil) or pull it over their head with the risk of suffocation. Keep packaging material away from children.

Warning and Safety instructions

Technical safety

▶ The refrigerant circuit has been checked for leaks. The refrigeration appliance complies with all current local and national safety requirements.



▶ Warning: Risk of fire / Flammable materials.

The refrigerant inside the appliance (details on the data plate) is environmentally friendly but flammable.

The use of this refrigerant does, however, sometimes lead to a slight increase in the noise level of the appliance. In addition to the noise of the compressor, you might be able to hear the refrigerant flowing around the system. Unfortunately, these effects cannot be avoided, but they do not affect the performance of the refrigeration appliance.

When transporting and installing the refrigeration appliance, ensure that no parts of the cooling circuit are damaged. Splashes of refrigerant can damage the eyes and leaking refrigerant can ignite.

In the event of any damage:

- Avoid naked flames or anything which creates a spark.
- Disconnect the refrigeration appliance from the mains electricity supply.
- Ventilate the room in which the appliance is located for several minutes.
- Call Miele.

▶ The more refrigerant there is in a refrigeration appliance, the larger the room should be in which it is installed. In the event of a leakage, if the appliance is in a small room, there is the danger of a combustible gas/air mixture building up. For every 8 g of refrigerant, at least 1 m³ of room space is required. The amount of refrigerant in the refrigeration appliance is stated on the data plate inside the appliance.

Warning and Safety instructions

- ▶ To avoid the risk of damage to the appliance, make sure that the connection data (fuse rating, frequency and voltage) on the data plate corresponds to the household supply. Check that this is the case before connecting the appliance. Consult a qualified electrician if in any doubt.
- ▶ The electrical safety of this appliance can only be guaranteed when correctly earthed. It is essential that this standard safety requirement is met. If in any doubt please have the electrical installation tested by a qualified electrician.
- ▶ Temporary or permanent operation with a self-sufficient or non-mains synchronous energy supply system (e.g. isolated networks, back-up systems) is possible. A requirement for the operation is that the energy supply system complies with all current local and national requirements that apply to stand-alone, solar and/or battery systems. The protective measures provided in the installation and in this Miele product must also be assured in their function and operation in isolated operation or in non-mains synchronous operation, or replaced with equivalent measures in the installation.
- ▶ If the connection cable is faulty, it must only be replaced by a Miele approved service technician in order to avoid a hazard.
- ▶ Do not connect the appliance to the mains electricity supply by a multi-socket unit or an extension lead. These do not guarantee the required safety of the appliance (e.g. danger of overheating).
- ▶ If moisture gets into electrical components or into the mains connection cable, it could cause a short circuit. Therefore, do not operate this refrigeration appliance in areas which are exposed to moisture (e.g. in a garage or laundry).
- ▶ This appliance must not be installed and operated in mobile installations (e.g. on a ship).
- ▶ Do not use a damaged appliance. It could be dangerous. Check the appliance for visible signs of damage.
- ▶ For safety reasons, this appliance may only be used when it has been fully installed.

Warning and Safety instructions

- ▶ During installation, maintenance and repair work, the appliance must be disconnected from the mains electricity supply. It is only completely isolated from the electricity supply when:
 - the mains circuit breaker has been switched off, or
 - the screw-out fuse is removed (in countries where this is applicable), or
 - it is switched off at the wall socket and the plug is withdrawn from the socket. Do not pull the mains connection cable but the mains plug to disconnect your appliance from the mains electricity supply.
- ▶ Repairs and other work by unqualified persons could be dangerous. Installation must be performed by a suitably qualified and competent person. Maintenance and repairs must only be carried out by a Miele authorised technician.
- ▶ The manufacturer's warranty will be invalidated if the appliance is not repaired by a Miele authorised technician.
- ▶ Faulty components must only be replaced with genuine Miele original spare parts. Miele can only guarantee the safety standards of the appliance when Miele spare parts are used.
- ▶ In areas which may be subject to infestation by cockroaches or other vermin, pay particular attention to keeping the appliance and its surroundings clean at all times. Any damage caused by cockroaches or other vermin will not be covered by the warranty.

Correct use

- ▶ This refrigeration appliance is designed for use within specific ambient temperatures (climate range). Do not use it in ambient temperatures for which it is not designed. The climate class is stated on the data plate inside the refrigeration appliance. A lower ambient temperature will cause the compressor to switch off for longer periods, meaning that the refrigeration appliance is unable to maintain the required temperature.
- ▶ To ensure proper air flow in and out of the appliance, the ventilation gaps in the appliance and built-in structure must not be covered or blocked in any way. This would also increase the energy consumption and could cause damage to the appliance.
- ▶ If storing food which contains a lot of fat or oil in the appliance or the appliance door, make sure that it does not come into contact with plastic components as this could cause stress cracks or break the plastic. Make sure that no fat or oil leaks onto the plastic parts of the appliance.
- ▶ Risk of fire and explosion! Do not store any explosive materials or products containing flammable propellants (e.g. spray cans) in the refrigeration appliance. Electrical components can cause flammable mixes of gases to ignite.
- ▶ Danger of explosion! Do not operate any electrical equipment (e.g. an electric ice cream maker) inside the appliance. Danger of sparking and explosion.
- ▶ Food stored for too long may present a risk of food poisoning. Storage times will depend on several factors, including the freshness and quality of the food, as well as the temperature at which it is stored. Follow the instructions given on the food manufacturer's packaging regarding storage conditions and use-by dates.
- ▶ Only use original Miele accessories. Using spare parts or accessories from other manufacturers will invalidate the warranty, and Miele cannot accept liability.

Warning and Safety instructions

Cleaning and care

- ▶ Do not use any oils or grease on the door seals, as these will cause the seals to deteriorate and become porous with time.
- ▶ Do not use a steam cleaning appliance to clean this appliance. Steam could reach the electrical components and cause a short circuit.
- ▶ Sharp edged or pointed objects will damage the evaporator, causing irreversible damage to the appliance. Do not use sharp edged or pointed objects to
 - remove frost and ice, or accelerate the defrosting process,
 - separate frozen foods and remove ice trays.
- ▶ Never place electric heaters or candles in the appliance to defrost it. These can damage the plastic parts.
- ▶ Do not use defrosting sprays or de-icers, as they might contain substances which could damage the plastic parts or which could cause a build-up of gases and pose a danger to health.

Transport

- ▶ To avoid damage to the appliance, always transport it upright and in its packaging.
- ▶ Risk of injury and damage! The refrigeration appliance is very heavy and must be transported by two people.

Disposal of your old appliance

- ▶ If your old appliance has a door lock, destroy it. This way you will prevent the risk of playing children accidentally locking themselves in and endangering their lives.
- ▶ Splashes of coolant can damage the eyes. Be careful not to damage any part of the pipework whilst awaiting disposal, e.g. by
 - puncturing the refrigerant channels in the condenser,
 - bending any pipework, or
 - scratching the surface coating.

Symbol on the compressor (depending on model)

This information is only relevant for recycling. There is no risk during normal operation.



- ▶ The oil in the compressor can be fatal if swallowed or if it penetrates the airways.

Caring for the environment

Disposal of the packing material

The transport and protective packaging has been selected from materials which are environmentally friendly for disposal, and can normally be recycled.

Recycling the packaging reduces the use of raw materials in the manufacturing process and also reduces the amount of waste in landfill sites.

Ensure that any plastic wrappings, bags etc. are disposed of safely and kept out of the reach of babies and young children. Danger of suffocation.

Only for Australia: Note for installer: Expanded polystyrene (EPS) packaging included. Please retain and dispose of EPS packaging responsibly. For further information, please contact Miele.

Disposing of your old appliance

Electrical and electronic appliances contain many valuable materials. They also contain certain materials, compounds, and components which were essential for their correct functioning and safety. These could be hazardous to human health and to the environment if disposed of with general waste or if handled incorrectly. Please do not, therefore, dispose of your old appliance with your household waste.



Take care not to damage your refrigeration appliance before or during disposal in an authorised, environmentally friendly manner. This is to ensure that refrigerant in the cooling circuit and oil in the compressor is contained, and will not leak into the environment.

Please dispose of it at your local community waste collection/recycling centre for electrical and electronic appliances, or contact Miele. You are also responsible for deleting any personal data that may be stored on the appliance prior to disposal. You should remove any old batteries which are not securely enclosed by the appliance and remove any lamps without destroying them, where this is possible. These must be taken to a suitable collection point where they can be handed in free of charge. Please ensure that your old appliance presents no danger to children while being stored awaiting disposal.

Saving energy

	Normal energy consumption	Increased energy consumption
Installation/ Maintenance	In a ventilated room.	In an enclosed, unventilated room.
	Protected from direct sunlight.	In direct sunlight.
	Not situated near a heat source (radiator, oven).	Situated near a heat source (radiator, oven).
	Where the ideal ambient room temperature is approx. 20 °C.	Where there is a high room temperature.
	Ventilation gaps kept uncovered and free of dust.	Where the ventilation gaps are covered or dusty.
Temperature settings	Refrigerator 4 to 5 °C	The lower the temperature in the appliance, the higher the energy consumption.

Saving energy

	Normal energy consumption	Increased energy consumption
Use	The drawers and shelves are arranged as they were when the appliance was delivered.	
	Only open the door when necessary and for as short a time as possible. Store food in an organised way.	Frequent opening of the door for long periods will cause a loss of coldness. The appliance will try to cool down, and the compressor will run for longer periods.
	Take a cooler bag when shopping and load food in the appliance as quickly as possible on your return home. Replace any food removed as quickly as possible, before it warms up too much. Allow hot food and drinks to cool down before placing them in the appliance.	Hot food or food at room temperature raises the temperature inside the appliance. The appliance will try to cool down and the compressor will run for longer periods.
	Store food well packaged or covered.	The evaporation or condensation of liquids in the refrigerator will cause a loss of coldness.
	Place frozen food in the refrigerator to defrost.	
	Do not overfill the appliance to allow air to circulate.	Poor air circulation will cause a loss of coldness.

Control panel

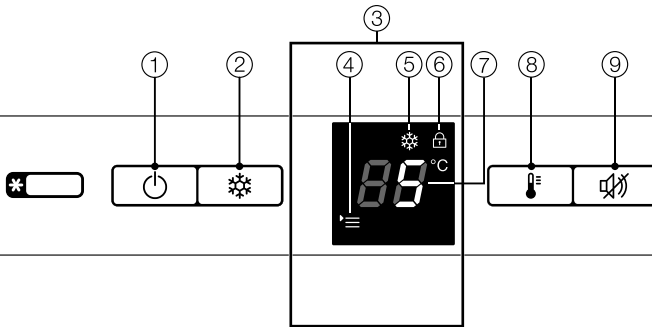

- ① On/Off button
- ② SuperCool button
- ③ Display
- ④ Menu symbol
(Settings mode:
Switching the safety lock on/off)
- ⑤ SuperCool symbol
- ⑥ Safety lock symbol
- ⑦ Temperature display
- ⑧ For setting the temperature
- ⑨ Alarm off button

Guide to the appliance

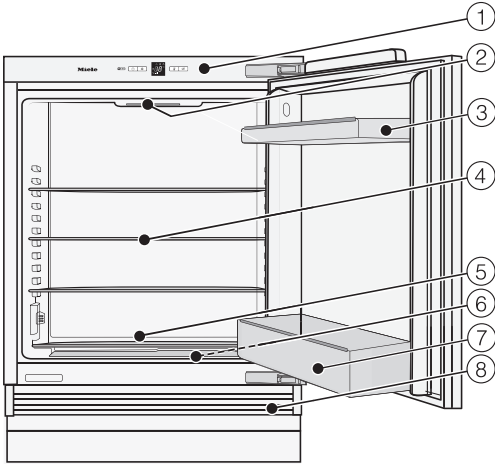

- ① Control panel with display
- ② Interior lighting
- ③ Egg tray/Door shelf
- ④ Adjustable shelf
- ⑤ Condensate channel and drain hole
- ⑥ Fruit and vegetable tray
- ⑦ Bottle shelf with bottle holder
- ⑧ Ventilation grille

Accessories

Accessories supplied

Bottle holder

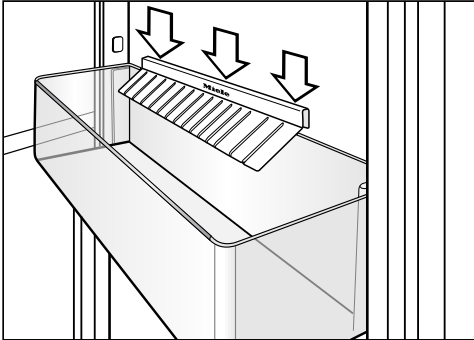

The fins of the bottle holder jut out into the bottle shelf and make bottles more secure when opening and closing the appliance door.

Egg tray

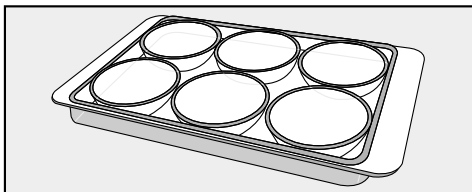

Optional accessories

A range of useful Miele accessories and care products is available for your appliance.

Accessories are available from Miele directly (see back cover for contact details).

Bottle rack

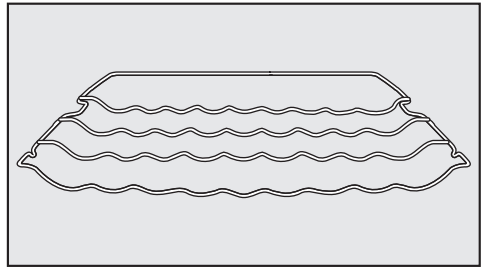

Bottles can be stored horizontally in the refrigerator section using the bottle rack to save space. The bottle rack can be placed in different positions in the refrigerator section.

Guide to the appliance

KKF-FF (Active AirClean) charcoal filter with holder

Charcoal filters neutralise unpleasant odours in the refrigerator section for improved air quality.

KKF-RF replacement charcoal filters (Active AirClean)

Replacement filters to fit the holder are available. We recommend replacing the charcoal filters every 6 months.

Miele all purpose microfibre cloth

Light soiling and fingerprints on stainless steel fronts, control panels and furniture can be easily removed with this microfibre cloth.

Before using for the first time

Removing packaging material

- Remove all packaging material from the inside of the appliance.

Removing the protective foil

The stainless steel strips of the shelves and the door shelves have a layer of protective foil to prevent scratching during transportation.

- Remove this protective foil after the appliance has been installed.

Cleaning the appliance

Please refer to the relevant instructions in “Cleaning and care”.

- Clean the inside of the appliance and the accessories.

Switching the appliance on

To enable the temperature to get sufficiently cold inside the appliance, allow the appliance to run for a few hours before placing food in it.

- Press the  button.

The appliance will start to cool and the selected temperature will appear in the temperature display. The interior lighting comes on when the door is opened.

Switching off the refrigerator

- Press the  button until the display goes out.

If this does not happen, the safety lock is activated (see “Further settings - Switching the safety lock on/off”).

The interior lighting goes out and the cooling switches off.

Switching on and off

Switching off for longer periods of time

If, during a long absence, the appliance is switched off but not cleaned and the door(s) left shut, there is a risk of mould forming inside the appliance.

It is essential to clean the appliance.

If the appliance is not going to be used for a longer period of time, observe the following:

- Switch the appliance off.
- Disconnect the appliance from the mains. Switch off at the wall and withdraw the plug from the socket, or switch off the mains circuit breaker.
- Clean the appliance and leave the door ajar to air the appliance and avoid odours building up inside.

The correct temperature

It is very important to set the correct temperature for storing food in the appliance. Bacteria will cause food which is not stored at the correct temperature to deteriorate rapidly. Temperature influences the growth rate of these microorganisms. Reducing the temperature reduces their growth rate. The temperature in the appliance will rise:

- The more often the door is opened and the longer it is kept open.
- The more food is stored in it.
- The warmer the food is which is being put into it.
- The higher the ambient temperature of the refrigeration appliance. The appliance is designed for use within specific ambient temperatures (climate range). Do not use it in ambient temperatures for which it is not designed.

... in the refrigerator section

We recommend a temperature of **4 °C** in the refrigerator section.

Temperature display

In normal operation the temperature display shows the **selected** temperature.

Setting the temperature

If the appliance door is opened very often, or if large quantities of food are being stored in the appliance, or if there is a high ambient temperature, it is advisable to set the temperature between **3 °C and 5 °C**.

The temperature can be adjusted between 9 °C and 2 °C.

- Press the  button repeatedly until the temperature you want is shown in the temperature display.

When first pressed: The last selected temperature flashes.

The temperature value will change until the setting for 9 °C is reached. Then it will start again at 2 °C.

After a short while the newly selected temperature is automatically saved and appears in the display.

The temperature in the appliance will adjust slowly to the newly set temperature.

Using SuperCool

SuperCool

The SuperCool function can be used to rapidly reduce the temperature in the refrigerator section to its lowest setting (depending on the room temperature).

SuperCool is particularly recommended for the rapid chilling of large amounts of fresh food or drinks.

Switching on SuperCool

- Press the ❄️ button.

The SuperCool symbol ❄️ lights up. The appliance will work at full power to lower the temperature in the refrigerator section.

Switching off SuperCool

The SuperCool function switches off automatically after approx. 12 hours. The SuperCool symbol ❄️ will go out and the appliance will run at normal power again.

To save energy, you can manually switch off the SuperCool function once food and drinks are sufficiently chilled.

- Press the ❄️ button until the ❄️ symbol goes out.

The appliance will operate at normal power again.

The appliance is fitted with a warning system to avoid increased energy consumption and food becoming warm if the door is left open.

Door alarm

An alarm will sound if the appliance door has been left open for longer than 60 seconds.

As soon as the door is closed, the alarm will stop.

Switching the door alarm off early

You can switch the alarm off early if you wish.

- Press the  button.

The alarm will stop.

The alarm tone cannot be switched off early if you are in settings mode.

Selecting further settings

Settings mode

The safety lock can be activated or deactivated in settings mode.

Switching the safety lock on/off	⌂
----------------------------------	---

Settings mode is indicated by the menu symbol '≡ in the display.

See below for instructions on how to **activate and deactivate the safety lock**.

Switching the safety lock on/off

The safety lock can be activated to prevent the appliance from being switched off by mistake.

– To activate the safety lock

- Press the  button for approx. 5 seconds.

The '≡ symbol lights up and ⌂ flashes in the display.

Settings mode is now activated.

- Press the  button briefly to access the safety lock function.

⌂1 appears in the display.

- Press the  button briefly to activate the safety lock.

The safety lock symbol  lights up.

- Touch the  button to exit settings mode.

The temperature appears in the display.

– To deactivate the safety lock

- Press the  button for approx. 5 seconds.

The safety lock symbol  and the menu symbol '≡ light up and ⌂ flashes in the display.

Settings mode is now activated.

- Press the  button briefly to access the safety lock function.

⌂1 appears in the display.

- Press the  button briefly to deactivate the safety lock.

The safety lock symbol  lights up.

- Touch the  button to exit settings mode.

The temperature appears in the display.

Storing food in the refrigerator section

Different storage zones

Due to the natural air circulation there are different temperature zones in the refrigerator.

Cold, heavy air sinks to the lowest section of the appliance. Make use of the different zones when placing food in the appliance.

Useful tip: To allow air to circulate efficiently, do not pack food too closely together in the refrigerator.

If there is insufficient air circulation, the cooling performance will decrease and energy consumption will increase.

Do not cover the fan in the rear wall of the appliance.

Useful tip: Do not store food in such a way that it touches the rear wall of the refrigerator. It may freeze to the back wall.

Warmest area

The warmest area is located in the top section of the main storage area and the door. Use this for storing butter so that it remains spreadable and for cheese so that it retains its flavour.

Coldest area

The coldest area in the refrigerator section is directly above the fruit and vegetable tray and at the back of the appliance.

Use these areas to store all delicate and highly perishable food, e.g.

- fish, meat, poultry
- sausage products, ready meals
- dishes or baked goods containing eggs or cream

- fresh dough, cake mixtures, pizza or quiche dough
- soft cheese and other dairy products
- pre-packed vegetables and other fresh food with a label stating it should be kept at a temperature of approx. 4 °C.

Food which is not suitable for storage in the refrigerator

Not all food is suitable for refrigeration at temperatures below 5 °C because it is sensitive to cold.

Foods which are sensitive to cold include:

- Pineapples, avocados, bananas, pomegranates, mangoes, melons, papayas, passionfruit and citrus fruits such as lemons, oranges, mandarines, grapefruits
- Fruit (which is not yet ripe)
- Eggplants, cucumbers, potatoes, capsicums, tomatoes, zucchini
- Hard cheeses, e.g. Parmesan, mountain cheese

Notes on buying food

The freshness of the food when it is first placed in the appliance is the most important factor for how long it stays fresh.

Take into account the use-by date and the correct storage temperature.

Time out of the refrigerator, e.g. transporting food in a warm car, should be kept to a minimum.

Storing food correctly

Ensure that food stored in the refrigerator section is **in packaging or covered properly**. This will prevent food smells from affecting other foods, food from drying out, and also

Storing food in the refrigerator section

crosscontamination of bacteria. This is especially important when storing meat products.

By ensuring that the temperature settings are correct and by taking appropriate hygiene measures, you can prolong the storage life of your food considerably and avoid food waste.

Protein rich food

Please note that foods rich in protein deteriorate faster than others. Shellfish, for example, deteriorates faster than fish, and fish deteriorates faster than meat.

Adjusting the interior fittings

Adjusting the door shelf/bottle shelf

Only move door/bottle shelves when they are empty.

- Push the door/bottle shelf upwards, then remove it by pulling it forwards.
- Replace the shelf at the required height. Ensure that it is securely pushed back into position.

Moving the adjustable shelves

The shelves can be adjusted according to the height of the food.

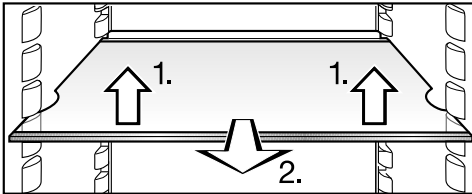

- Raise the shelf and pull it forwards slightly until the notch at the side is in line with the shelf support. It can then be raised or lowered to the required level.

The raised edge on the protective strip at the back must face upward to prevent food from touching the back of the appliance and freezing to it.

Stoppers prevent the shelves from being dislodged by mistake.

Adjusting the bottle holder

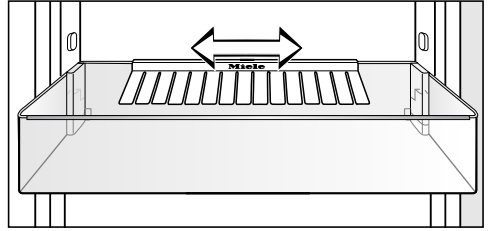

The bottle holder can be moved to the left or right to create more room for drink cartons.

The bottle holder can be removed completely, e.g. for cleaning:

- Lift up the bottle shelf and pull it towards you to remove it.
- Detach the bottle holder from the back edge of the bottle shelf.

Adjusting the interior fittings

Moving the charcoal filters

Charcoal filters and a KKF-FF (Active AirClean) holder are available as optional accessories (see “Guide to the appliance - Optional accessories”).

When you are storing very strong smelling food (e.g. very ripe cheese):

- Place the holder with the charcoal filters on the shelf where this food is kept.
- Change the charcoal filters sooner if necessary.
- Use more charcoal filters (with holders) in the appliance (see “Accessories - Optional accessories”).

The holder for the charcoal filters sits on the protective strip at the back of the shelf.

- To move the charcoal filters, pull the holder upwards to remove it from the protective strip.

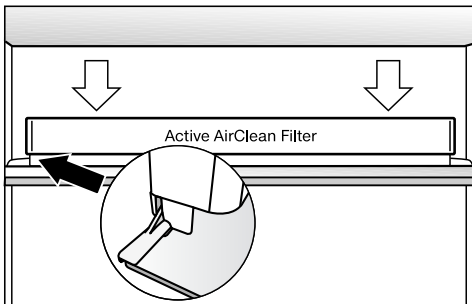

- Refit it on the protective strip of the shelf you wish to use it on.

Refrigerator section

The refrigerator section defrosts automatically.

Condensate and frost can build up on the back wall of the refrigerator section while the compressor is running. You do not need to remove this, as it will defrost and evaporate automatically with the warmth generated by the appliance.

The condensate is drained away through a channel and drain hole, then fed into an evaporation system at the back of the appliance.

Keep the condensate channel and drain hole clean to enable this. Condensate must be able to drain away unhindered at all times.

Cleaning and care

Do not let water get into the electronic unit or the lighting.

 Risk of damage due to moisture ingress.

The steam from a steam cleaning appliance can damage plastic parts and electrical components.

Do not use a steam cleaner to clean the appliance.

Cleaning water must not get into the drain hole.

The data plate located inside the appliance must not be removed. It contains information which is required in the event of a fault.

Cleaning agents

Cleaning and conditioning agents used inside the appliance must be food safe.

To avoid damaging the surfaces of your appliance, **do not use:**

- cleaning agents containing soda, ammonia, acids or chlorides,
- cleaning agents containing descaling agents,
- abrasive cleaning agents, e.g. powder cleaners and cream cleaners,
- solvent-based cleaning agents,
- stainless steel cleaning agents,
- dishwasher cleaner,
- oven sprays,
- glass cleaning agents,
- hard, abrasive sponges and brushes, e.g. pot scourers,
- dirt erasers,
- sharp metal scrapers.

We recommend using lukewarm water with a little washing-up liquid to clean the appliance.

The following pages contain important information on cleaning.

Preparing the appliance for cleaning

- Switch the appliance off.

The display goes dark and the cooling is switched off.

If this is not the case, the safety lock is on (see “Further settings - Switching the safety lock on/off”).

- Take any food out of the appliance and store it in a cool place.
- Remove the door shelves and the bottle shelves from the door.
- Take out all other removable parts for cleaning.

Adjustable shelf

- Place the shelf on a worktop covered with a soft material (e.g. a tea towel).

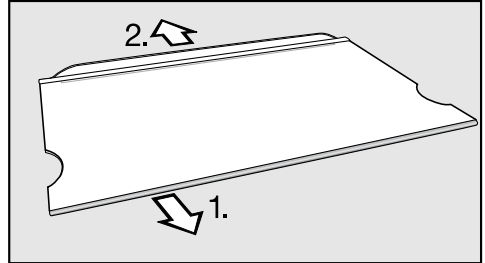

- Remove the strip:
 1. Pull the stainless steel strip off the shelf beginning at one side.
 2. Then pull the protective strip off.
- Reattach the strips after cleaning the shelf.

Cleaning and care

Cleaning the interior and accessories

The appliance should be cleaned regularly, or at least once a month.

Clean up any spills, stains or food immediately. Do not allow them to dry and stick to the appliance.

- Clean the **interior** with a clean sponge, lukewarm water and a little washing-up liquid.
- After cleaning, wipe with a clean, damp cloth and then dry with a soft cloth.

Remove the stainless steel strips before cleaning the adjustable shelves in a dishwasher.

The following parts **are not dishwasher-safe**:

- the stainless steel strips
- the fruit and vegetable tray
- Clean these parts by hand.

 Risk of damage as a result of excessively high dishwasher temperatures.

Some parts of the appliance may become unusable, e.g. deform, if they are washed in the dishwasher at more than 55 °C.

For the dishwasher-safe parts, only use dishwasher programmes with a maximum temperature of 55 °C.

Contact with natural dyes from carrots, tomatoes and ketchup may discolour the plastic parts in the dishwasher. This discolouration does not affect the stability of the parts.

The following parts are **dishwasher-safe**:

- the bottle holder, egg tray
- the bottle and door shelves in the door
- the adjustable shelves (with the strips removed and without the printing)
- the holder for the charcoal filter (available as an optional accessory)
- Clean the condensate channel and drain hole frequently using a straw or cotton tip or similar item to ensure that condensate can drain away freely.
- Leave the door open to air the appliance for a short while and to prevent odours building up.

Cleaning the door seals

If a door seal is damaged or has come out of the groove, the door will not close properly and cooling performance will be reduced. Condensate will build up in the interior and this can cause a build-up of ice.

Do not damage the door seals and ensure that they do not come out of their groove.

 Risk of damage due to incorrect cleaning.

If you treat the door seals with oils or grease, they can become porous.

Do not use any oils or grease on the door seals.

- The door seals should be cleaned regularly with clean water, and then wiped dry with a soft cloth.

Cleaning the ventilation gaps

A build-up of dust will increase the energy consumption of the appliance.

- The ventilation gaps should be cleaned on a regular basis with a brush or vacuum cleaner (you could use a Miele Vacuum Cleaner dusting brush, for example).

Starting up the appliance after cleaning

- Refit all shelves and accessories in the appliance.
- Reconnect to the mains and switch the appliance back on.
- Switch on the SuperCool function for a while so that the refrigerator section can cool down quickly.
- Place food back in the refrigerator section and close the door.

Cleaning and care

Replacing the charcoal filters

Charcoal filters and a KKF-FF (Active AirClean) holder are available as optional accessories (see “Guide to the appliance - Optional accessories”).

Replace the charcoal filters in the holder every 6 months.

Replacement KKF-RF charcoal filters are available from Miele or via the internet at shop.miele.com.

Useful tip: The holder for the charcoal filters is dishwasher-safe.

- Pull the charcoal filter holder upwards to remove it from the shelf.

When in position the charcoal filters must not touch the back wall of the appliance as the moisture could cause them to stick to the back wall. Insert the new charcoal filters into the holder so that they do not protrude over the edge of the holder.

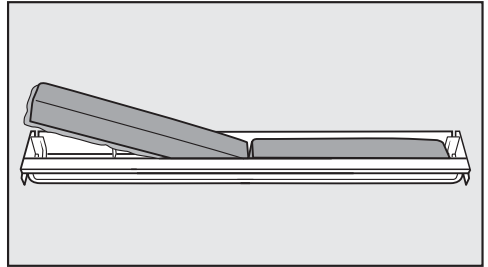

- Remove both charcoal filters and place the new filters with the raised edge pointing downwards in the holder.

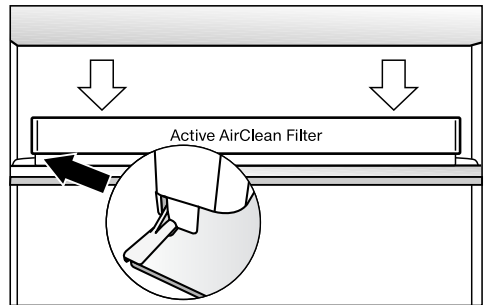

- Place the holder in the middle of the raised edge at the back of the shelf so that it clicks into position.



Problem solving guide

Many malfunctions and minor faults that can occur in daily operation can be corrected without contacting Miele. This will save you time and money because you will not need a service call.

You can find information on how to remedy faults yourself at www.miele.com.au/service or www.miele.co.nz/service and on the Miele website.

Please note, however, that a call-out charge will be applied to unnecessary service visits where the problem could have been rectified as described in these operating instructions.

To prevent cold from escaping, avoid opening the appliance door until the fault has been corrected.

Problem	Possible cause and remedy
The appliance is not getting cold, the interior lighting does not come on when the door is opened, and the display is not lit up.	The appliance is not switched on and the mains connection symbol  is lit up in the display. <ul style="list-style-type: none"> ■ Switch the appliance on.
	The plug is not correctly inserted into the socket or not switched on at the socket. <ul style="list-style-type: none"> ■ Insert the plug correctly into the socket and switch on. The mains connection symbol  appears in the display when the appliance is switched off.
	Check whether the mains circuit breaker has tripped. There could be a fault with the appliance, the household electrical wiring or another electrical appliance. <ul style="list-style-type: none"> ■ Contact a qualified electrician or Miele.
The compressor is switching on more frequently and runs for longer periods of time, and the temperature in the appliance is too low.	The ventilation gaps are covered or have become too dusty. <ul style="list-style-type: none"> ■ Do not block the ventilation gaps. ■ Clean the dust from the ventilation gaps on a regular basis.
	The door has been opened too frequently, or a large amount of fresh food has been placed inside the appliance. <ul style="list-style-type: none"> ■ Only open the door when necessary and for as short a time as possible. After a while the temperature will return to normal by itself.
	The door is not properly closed. <ul style="list-style-type: none"> ■ Close the appliance door.



Problem solving guide

Problem	Possible cause and remedy
	<p>After a while the temperature will return to normal by itself.</p> <p>The ambient room temperature is too high. The higher the room temperature, the longer the compressor will run. ■ See the information in “Installation – Location”.</p> <p>The appliance was not properly installed in the niche. ■ See “Installation - Building in the appliance”.</p> <p>The temperature setting is too low. ■ Correct the temperature setting.</p> <p>The SuperCool function is still switched on. ■ To save energy, you can switch SuperCool off early yourself.</p>
<p>The compressor comes on less and less often and for shorter periods of time. The temperature in the appliance rises.</p>	<p>This is not a fault. The temperature is too high. ■ Correct the temperature setting. ■ Check the temperature again after 24 hours.</p>
<p>An alarm is sounding.</p>	<p>The door alarm has been activated (see also “Door alarm”). ■ Close the appliance door. The alarm will stop.</p>
<p>The door seal is damaged and needs to be replaced.</p>	<p>No tools are required to change the door seal. ■ Change the door seal. A replacement is available from Miele.</p>
<p>Ice or condensation has built up inside the refrigeration appliance. The appliance door may not close correctly.</p>	<p>The door seal has come out of its groove. ■ Check that the door seal is correctly seated in the groove.</p> <p>The door seal is damaged. ■ Check if the door seal is damaged.</p>

Problem solving guide



Problem	Possible cause and remedy
<p>An LED indicator light is flashing at the back of the appliance at the bottom near the compressor (depending on model). The electronic unit for the compressor is equipped with an operation and fault diagnosis LED indicator light.</p>	<p>The indicator light flashes several times every 5 seconds. A fault has occurred. ■ Call Miele.</p>
	<p>The indicator light flashes regularly every 15 seconds. Not a fault. This flashing is normal.</p>

Messages in the display

Message	Possible cause and remedy
<p>The  symbol lights up in the display and the appliance does not get cold, although the controls and the interior lighting are working.</p>	<p>Demo mode is switched on. In this mode, the appliance can be presented in a showroom without the cooling system working. Do not activate this setting for domestic use. ■ Contact Miele for information on how to deactivate Demo mode.</p>
<p>“F0 to F9” appears in the display.</p>	<p>There is a fault. ■ Call Miele.</p>
<p>The  symbol lights up in the display. You cannot switch the appliance off.</p>	<p>The safety lock has been activated. ■ Deactivate the safety lock (see “Further settings – Switching the safety lock on/off”).</p>

Problem solving guide

The interior lighting is not working

Problem	Possible cause and remedy
The interior lighting is not working.	<p>The appliance is not switched on.</p> <ul style="list-style-type: none">■ Switch the appliance on.
	<p>To avoid overheating, the interior lighting switches itself off automatically after approx. 15 minutes if the door is left open. If this is not the case, there is a fault.</p>
	<div data-bbox="404 424 1041 699" style="border: 1px solid gray; padding: 5px;"><p> Risk of electric shock due to exposed, live electrical components!</p><p>When removing the lighting cover, there is a risk of coming into contact with live electrical components.</p><p>Do not remove the lighting cover. The LED lighting must only be repaired or replaced by a qualified technician.</p></div> <div data-bbox="404 715 1041 930" style="border: 1px solid gray; padding: 5px; margin-top: 10px;"><p> Danger of injury from LED lighting!</p><p>This lighting corresponds to risk group RG 2. If the cover is defective, the eyes may be injured.</p><p>If the lighting cover is defective, do not look from a close range directly into the lighting with optical instruments (e.g. magnifying glass or similar).</p></div> <ul style="list-style-type: none">■ Call Miele.

Other problems

Problem	Possible cause and remedy
The floor of the refrigerator is wet.	The condensate drain hole is blocked. ■ Clean the condensate channel and drain hole.
The external walls of the appliance feel warm.	This is not a fault. The heat which results from the cooling process is used to avoid the build-up of condensation on the appliance.

Noises

Normal noises	What causes them
Brrrr ...	A humming noise is made by the compressor. This noise can get louder for brief periods when the compressor switches on.
Blubb, blubb ...	A gurgling noise can be heard when refrigerant is circulating through the pipes.
Click ...	Clicking sounds occur whenever the thermostat switches the compressor on or off.
Crack ...	A cracking sound can be heard when materials expand inside the appliance.

Please bear in mind that the noise of the compressor and the coolant circulating in the system is unavoidable.

Noises	Possible cause and remedy
Rattling, vibrating, clinking	The appliance is uneven. Realign the appliance using a spirit level, by raising or lowering the screw feet underneath the appliance or place something underneath it.
	The appliance is touching another appliance or piece of furniture. Move it away.
	Drawers, baskets or shelves are unstable or sticking. Check all removable items and refit them correctly.
	Bottles or containers are touching each other. Separate them.
	The transport cable clips are hanging loose at the back of the appliance. Remove the cable clips.

Contact in case of fault

In the event of any faults which you cannot remedy yourself, please contact Miele.

You can book a Miele customer service call-out online at www.miele.com.au/service or www.miele.co.nz/service.

Contact information for Miele can be found at the end of this booklet.

Please quote the model and serial number of your appliance when contacting Miele. This information can be found on the data plate.

The data plate is located inside the refrigeration appliance.

Warranty

The manufacturer's warranty for this appliance is 2 years.

For more information about country-specific warranty terms and conditions, please contact Miele.

Electrical connection

The appliance is supplied with a mains cable and moulded plug ready for connection to an AC single-phase 220–240 V 50 Hz supply.

The fuse rating must be at least 10 A.

This appliance must be connected to a suitable switched socket. The electrical installation must be in compliance with current local and national safety regulations.

The socket must not be concealed behind the appliance and must be easily accessible so that the appliance can be quickly disconnected from the electricity supply in case of an emergency.

If the socket is no longer accessible after installation, an additional means of disconnection must be provided for all poles. Suitable means of disconnection include switches with an all-pole contact gap of at least 3 mm. These include isolator switches, fuses and relays.

The mains plug and mains connection cable must not come into contact with the back of the appliance as vibrations can cause damage to these components. This could result in a short circuit.

Nor should other appliances be plugged into a socket located directly behind this appliance.

Do not connect the appliance to the mains electricity supply using an extension lead. Extension leads do not guarantee the required safety of the appliance (e.g. danger of overheating).

Temporary or permanent operation with a self-sufficient or non-mains synchronous energy supply system (e.g. isolated networks, back-up systems) is possible. A requirement for the operation is that the energy supply system complies with all current local and national requirements that apply to stand-alone, solar and/or battery systems”.

The protective measures provided in the domestic installation and in this Miele product must also be assured in their function and operation in isolated operation or in non-mains synchronous operation, or replaced with equivalent measures in the installation.

If the mains cable needs to be replaced, this must be done by a qualified and competent electrician.

This appliance must be built in, otherwise it could tip over.
Keep the appliance door(s) shut until the appliance has been built in and secured in its housing in accordance with these operating and installation instructions.

 Fire risk and damage! This refrigeration appliance must not be installed underneath a cooktop.

Location

This appliance should be installed in a dry, well-ventilated room.

When deciding where to install your appliance please bear in mind that it will use more energy if installed near a heater, cooktop or other appliance that gives off heat. Direct sunlight should also be avoided.

The higher the room temperature, the longer the compressor will run and the higher the energy consumption will be.

When installing the appliance, please note:

- The mains socket must not be located directly behind the appliance and must be easily accessible.
- The plug and cable must not touch the rear of the appliance as they could be damaged by vibrations from the appliance.
- Nor should other appliances be plugged into a socket located directly behind this appliance.

 Risk of damage due to high humidity.

In environments with high humidity, condensation can build up on external appliance panels, which can cause corrosion.

Install the refrigeration appliance in a dry and/or air-conditioned room with sufficient ventilation.

After installation, make sure that the appliance door closes properly, the ventilation gaps are not covered and that the refrigeration appliance has been installed in accordance with the operating and installation instructions.

Climate range

This refrigeration appliance is designed for use within specific ambient temperatures (climate range). Do not use it in ambient temperatures for which it is not designed. The climate class is stated on the data plate inside the refrigeration appliance.

Climate range	Ambient temperature
SN	10 to 32 °C
N	16 to 32 °C
ST	16 to 38 °C
T	16 to 43 °C
SN-ST	10 to 38 °C
SN-T	10 to 43 °C

A lower ambient temperature leads to the compressor switching off for longer periods. This can cause the internal temperature in the appliance to rise with the risk of food deteriorating and going off.

Installation advice

Ventilation

 If the required ventilation gaps are not adhered to, the compressor will switch on more often and run for longer.

This will result in increased energy consumption and a higher operating temperature of the compressor. This, in turn, may cause damage to the compressor.

It is essential to observe the required ventilation gaps (see “Building-in dimensions”).

Ventilation takes place through a ventilation grille in the appliance plinth.

The ventilation gaps must not be covered or blocked in any way. They must also be cleaned on a regular basis to remove dust.

Furniture door

Gap size

The thickness and edge radius of the furniture door and the gap that runs around the door, vertically and horizontally, are specified depending on the style of the kitchen furniture.

It is essential to pay attention to the following:

If the gap between the appliance furniture door and the adjoining housing unit door or wall on the hinged side is too small, the appliance door could collide with the adjoining housing unit door or wall when opened.

It may be necessary to adjust the size of this gap to suit the thickness and edge radius of the appliance furniture door.

This must be taken into consideration when planning your kitchen and when replacing an old appliance with a new one to ensure the required installation conditions are met.

Installation advice

Appliance furniture door thickness A [mm]	Gap X [mm] for different edge radii B			
	R0	R1.2	R2	R3
≥16 - 19	min. 3			
20	5	4	4	3.5
21	5.5	5	4.5	4
22	6.5	6	5.5	5

Useful tip: Fit a spacer between the housing unit body and the side wall. This way you will get a sufficiently wide gap.

Weight of the furniture door



If the door panel is too heavy, this can cause damage!

Fitting a furniture front which is heavier than the maximum permitted weight could damage the hinges. Among other things, this damage can lead to functional impairments.

Before fitting furniture doors, ensure that the weight of the door does not exceed the maximum weight permitted:

Before fitting furniture doors, ensure that the weight of the door does not exceed the maximum weight permitted:

Appliance	maximum weight of furniture door
K 31222 Ui	10 kg

Installation advice

Before installing the appliance

- Take the accessory pack which includes installation parts and other accessories out of the appliance.
- Remove any cable clips from the back of the appliance.

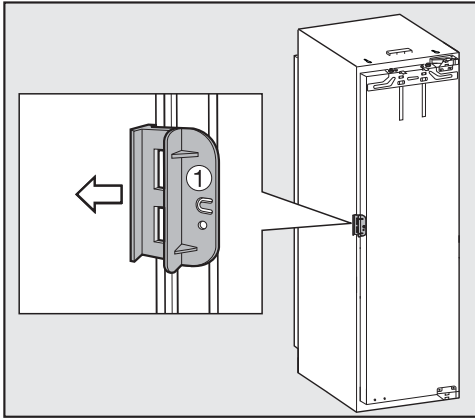

- Open the appliance door and remove the red transport clips ① (depending on model).

Building-in dimensions

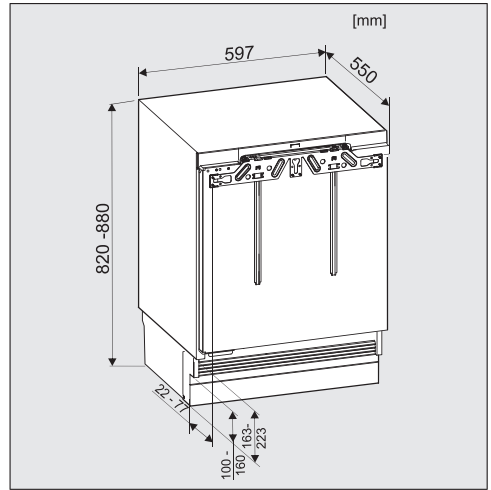

Appliance dimensions

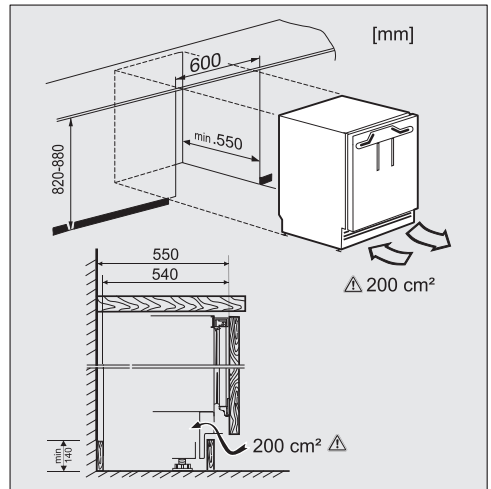

Dimensions for the ventilation

Changing the door hinging

Changing the door hinging

Always change the door hinging with the assistance of another person.

The appliance is supplied with right-hand hinging. If left-hand hinging is required, the hinges must be changed.

To change the door hinging, you will need the following tools:

- Open the appliance door.
- Remove the adjustable shelves/bottle shelf from the appliance door.

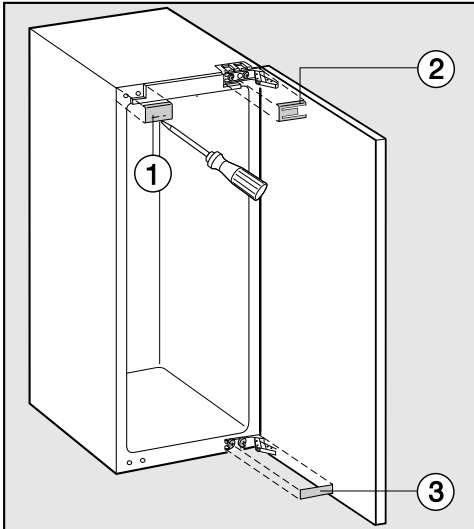

- Lift off covers ①, ② and ③.

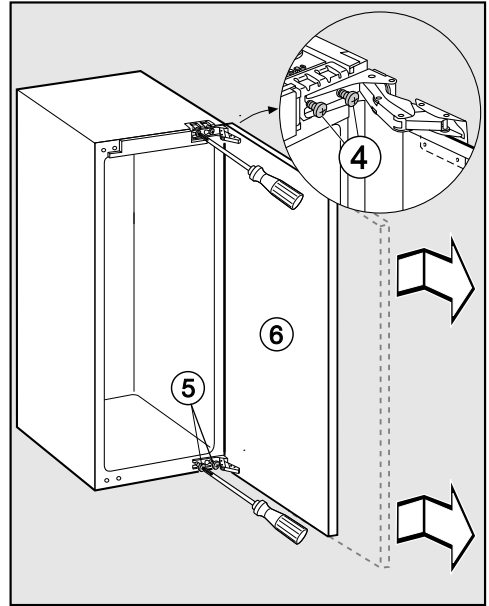

- Slightly loosen screws ④ and ⑤ on the hinges.
- Push the door ⑥ outwards and take it off its hinges.
- Unscrew the screws ④ completely and loosely screw them in on the opposite side.
- Unscrew the screws ⑤ completely and loosely screw them in on the opposite side.

Changing the door hinging

Fitting the door

- Place the door with the outer side downwards on a stable surface.

Danger of injury!

Do not close the hinges.

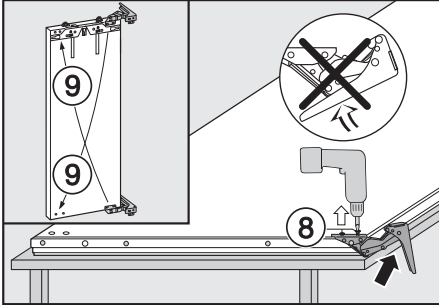

- Undo the screws (8).
- Place each hinge on the diagonally opposite side (9).

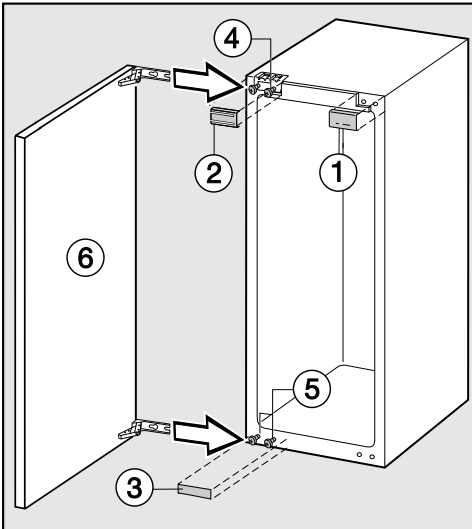

- Hang the appliance door (6) onto the pre-fitted screws (4) and (5), and securely tighten the screws (4) and (5).
- Replace covers (1), (2) and (3).

Adjusting the door hinge

Adjusting the spring force of the appliance door

If you would like the appliance door to be cushioned so that it opens more softly, the spring tension on the appliance door can be adjusted.

To do this, use an Allen key to adjust the door hinges.

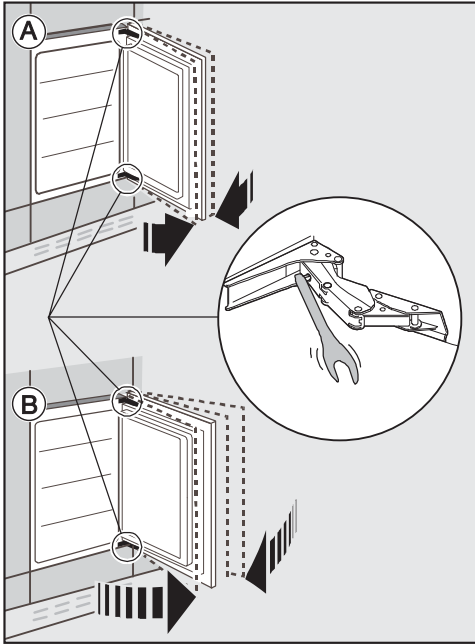

(A) To increase the door opening resistance:

- Turn the Allen key clockwise.

This tightens the hinges and makes it harder to open the door wide.

(B) To decrease the door opening resistance:

- Turn the Allen key anti-clockwise.

The hinge is looser, making it easier to open the door.

Limiting the opening angle of the door

The door hinges are set at the factory to enable the door to be opened wide.

If the opening angle of the appliance door needs to be limited to approx. 90°, the hinge can be adjusted to accommodate this.

The locking pins for limiting the door opening must be fitted before the appliance is installed.

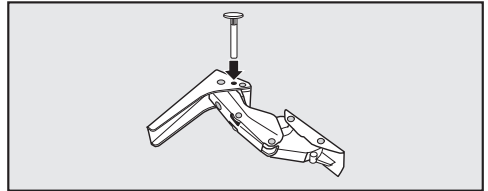

- Place the locking pins supplied for limiting the door opening into the hinges from above.

The door opening angle is now limited to 90°.

Installing the appliance

To install the appliance, you will need the following tools:

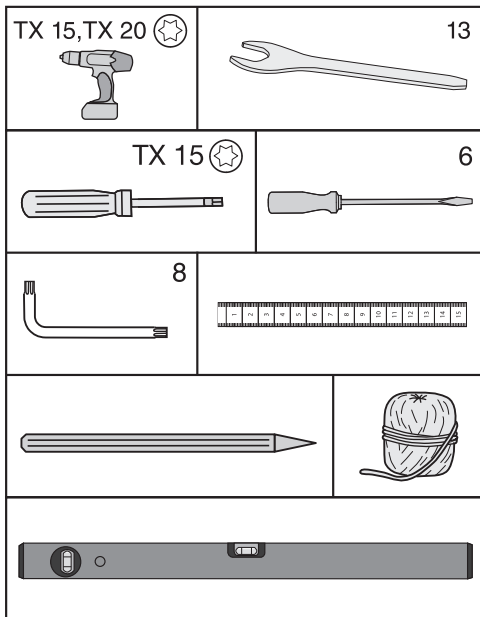

Parts required for installation

All installation parts are designated by number. This numbering is also used in the installation instructions.

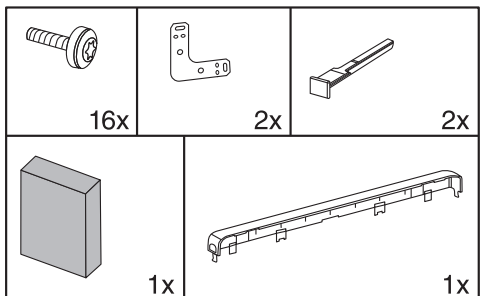

Preparing the appliance

- Position the appliance in front of the housing unit.
- Grasp the plinth cover at the side and pull it off towards the front.

You have a choice of two different ways of securing your appliance:

1. Top mounting
This type of mounting is suitable for mounting under worktops made of synthetic materials, e.g. laminate. The worktop must be suitable for screwing a mounting bracket onto. With the appliance feet fully extended the appliance should sit lightly tensioned between the floor and the worktop.
2. Side mounting
This type of mounting is suitable for mounting under hard worktops, e.g. granite. Furniture side walls are needed to the right and left of the refrigerator, to which the mounting brackets can be screwed. With the feet fully extended the refrigeration appliance will sit lower than the worktop.

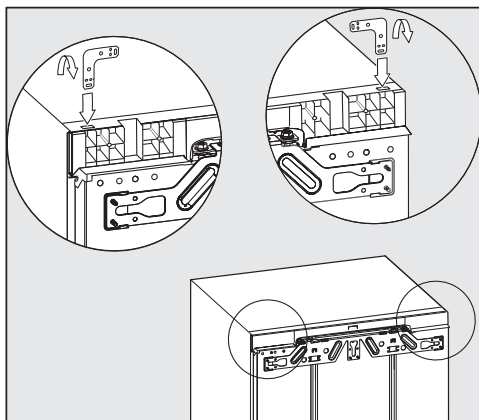

1. Top mounting

Installing the appliance

- Fit the bracket in the opening in the appliance lid.
- Bend the bracket at the perforated point.

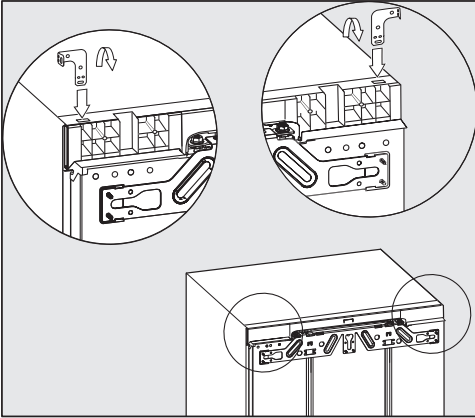

2. Side mounting

Both ends of the bracket must be bent.

- Fit the bracket in the opening in the appliance lid.
- Bend the bracket at the perforated point.
- Remove the bracket from the opening and insert the straight end of the bracket.
- Now bend this end of the bracket at the perforated point.

Pushing the appliance into its niche

⚠ When pushing the appliance into its niche make sure that the mains cable does not get trapped.

⚠ Move the appliance carefully on floors that are sensitive to scratching to prevent damage.

⚠ The appliance feet can break off. The feet should be almost fully screwed in when you push the appliance into the niche.

Useful tip: Loosen the two rear feet by half a turn before pushing the appliance in. After pushing it into the niche the feet will be easier to adjust from the front (see “Aligning the appliance”).

- Position the mains electricity cable so that the appliance can be connected easily once installed.

Useful tip: To help you push the appliance into position, tie a piece of string around the plug to “increase” the length of the connection cable. Then pull the cable by the end of the string through the housing unit.

Installing the appliance

If the appliance is pushed too far into the niche, the door may not close properly once the furniture panel has been fitted. This can cause ice to build up, condensate to accumulate and lead to faults in the appliance. These can all lead to increased energy consumption.

Push the appliance into the building-in niche making sure a gap of **42 mm** is maintained all round between the appliance body and the front of the housing unit side walls.

- Push the appliance into the niche until the front edges of the hinges at the top and bottom are flush with the front edge of the housing unit side wall.

This will create a gap all round of **42 mm** to the front edges of the housing unit side walls.

With **furniture with door fittings (e.g. stubs, seals etc.)** the dimension of these must be taken into account when making sure there is a gap all round of **42 mm**.

- Pull the appliance forwards by the appropriate dimension.
- Check again to make sure there is a gap of **42 mm** to the front edges of the door fittings.

Useful tip: If possible, remove door fittings and push the appliance into the niche until all fixing brackets at the top and bottom are in line with the front edge of the housing unit side wall.

Installing the appliance

Aligning the appliance

When securing the appliance in the niche at the top, the appliance should sit lightly tensioned between the floor and the worktop.

- Adjust the front and rear feet alternately according to the height of the niche and make sure the appliance is correctly aligned.

Proceed as follows:

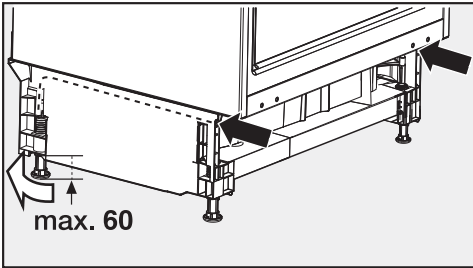

- Adjust both rear feet with appropriate screws at the front right and left in the appliance plinth using a flat-tip screwdriver.

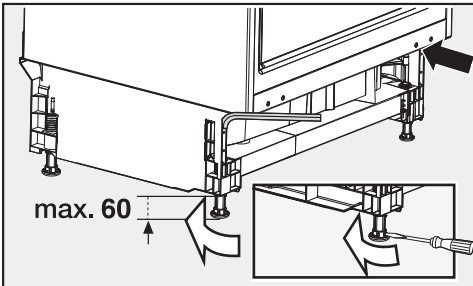

- Use an Allen key to unscrew both front feet.

Useful tip: As soon as the feet have been unscrewed slightly, you can adjust them with a screwdriver at the bottom of the foot (see small illustration).

 The foam ① ensures the airflow is separated to prevent malfunctioning of the appliance.

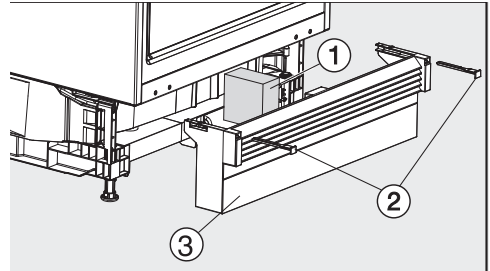

- Insert the piece of foam ① supplied.
- Refit the plinth panel ③, but do not secure it in position yet.

Without a continuous plinth panel:

- Pull the plinth panel ③ forwards until the ventilation slats are in alignment with adjacent cabinet plinth panels.
- Hold the plinth panel securely and attach it to the right and left using the bolts supplied ②.

With a continuous plinth panel:

- Push the plinth panel ③ right up against the refrigerator and attach it to the right and left using bolts ②.

Installing the appliance

Fitting a continuous furniture plinth panel

Ventilation takes place through a ventilation grille in the appliance plinth.
The ventilation gaps must never be obstructed.

If a continuous plinth panel is to be fitted, a suitable ventilation gap will need to be made in it for the ventilation grille of the appliance:

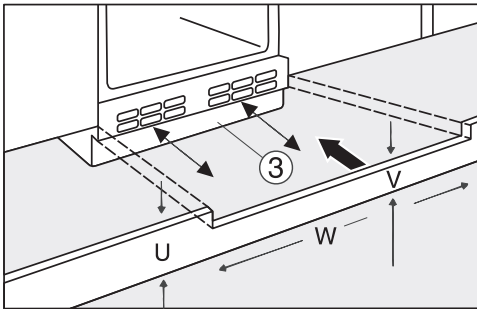

- Trim the furniture plinth panel (U) to the correct height.
- Adjust the height (V) along the niche width (W) underneath the appliance plinth ③.

Securing the appliance in the niche

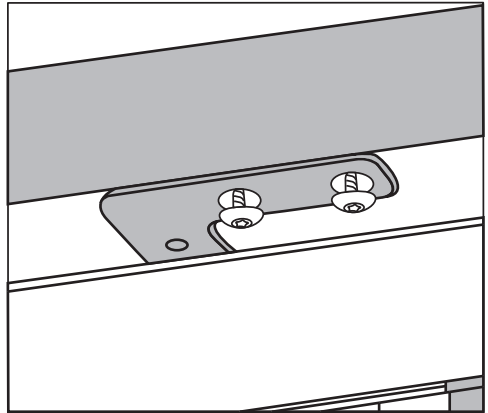

1. Top mounting

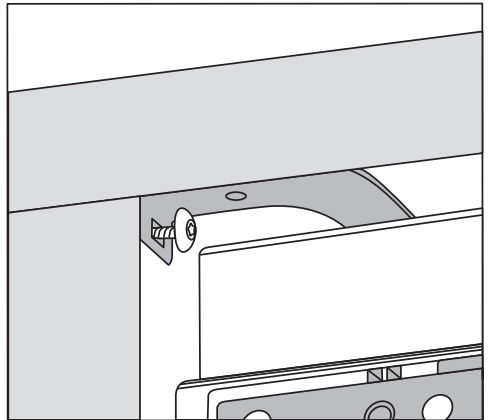

2. Side mounting

- Screw the appliance into position on the right and the left.

Installing the appliance

Fitting a furniture door

If the appliance is being built into a run of units, the height of the furniture door should be aligned with adjacent kitchen units.

The furniture door must be mounted plane and free of tension.

The following chapter describes the installation of a furniture door with a furniture front of at least 16-19 mm thickness.

Ensure that the plinth panel is refitted correctly.

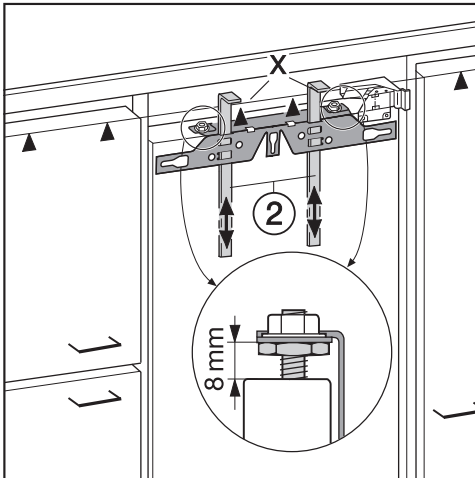

- A gap of 8 mm is set at the factory between the appliance door and the fixing bracket. Double-check this gap and adjust it if necessary.
- Push the fitting aids (2) up to the height of the furniture door: the lower edge X of the fitting aids must be at the same height as the upper edge of the furniture door being fitted (see ▲ in diagram).

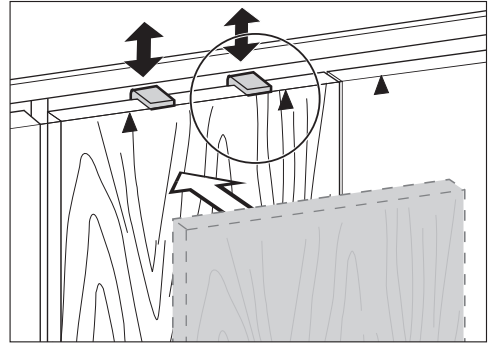

Useful tip: Push up the fitting aids (2) with the furniture front.

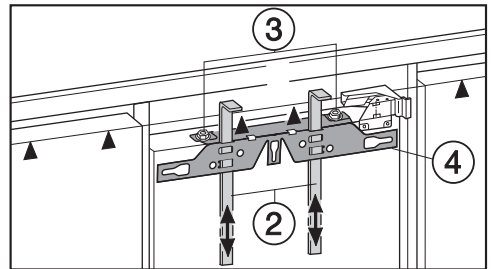

- Undo the nuts (3) and take the fixing bracket (4) off together with the fitting aids (2).

Installing the appliance

- Place the furniture door with the outer side downwards on a stable surface.

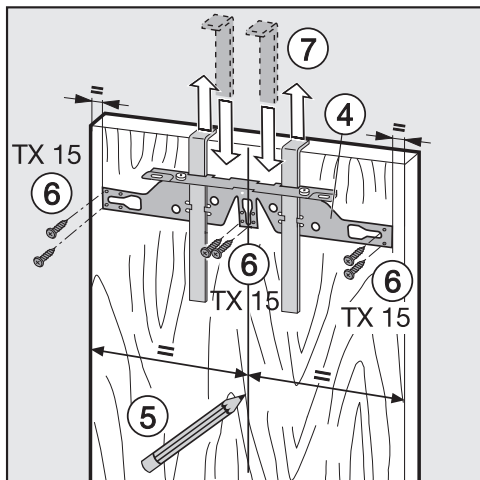

- Using a pencil, lightly mark a line down the centre of the inside of the furniture door (5).
- Hang the fixing bracket (4) with the fitting aids onto the **inside** of the furniture door. Align the fixing bracket centrally.
- Attach the fixing bracket securely using at least 6 short chipboard screws (6). (On cassette doors only use 4 screws on the edges). Drill pilot holes into the furniture door if necessary.
- Pull the fitting aids upwards to remove them (7). Turn them around and fit them into the middle slots on the fixing bracket for safe keeping.

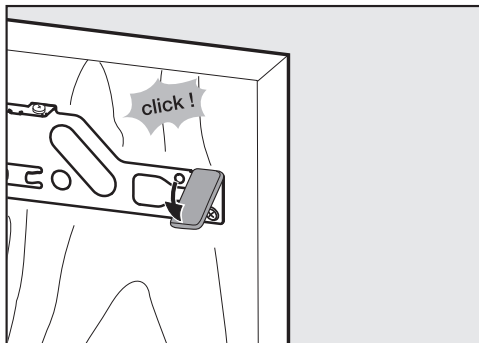

- Fit the side cover to the fixing bracket on the opposite side of the hinge.
- Turn the furniture door over and attach the handle (if needed).

Installing the appliance

- Open the appliance door.

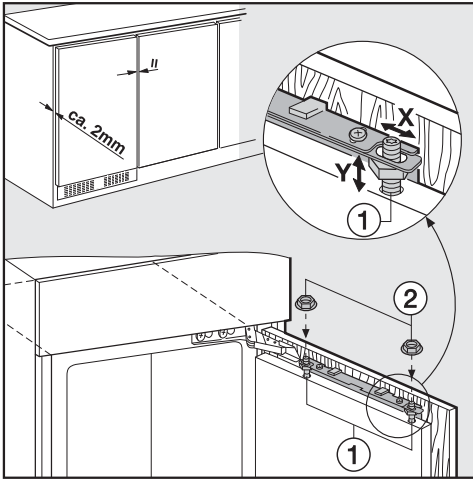

- Hang the furniture door onto the adjusting bolts ①.
- Loosely attach the nuts ② on the adjusting bolts.
- Close the door and check the distance between the door and neighbouring furniture doors.
- Align to match neighbouring doors if necessary:
Side adjustments X are made by sliding the furniture door, and height adjustments Y by turning the adjusting bolts ① with a screwdriver.

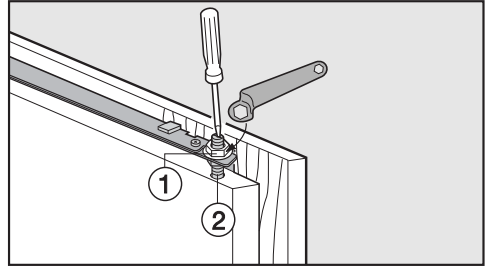

- Whilst counterholding the adjusting bolts ② with a screwdriver, tighten the nuts ① on the appliance door with screwdriver.

Installing the appliance

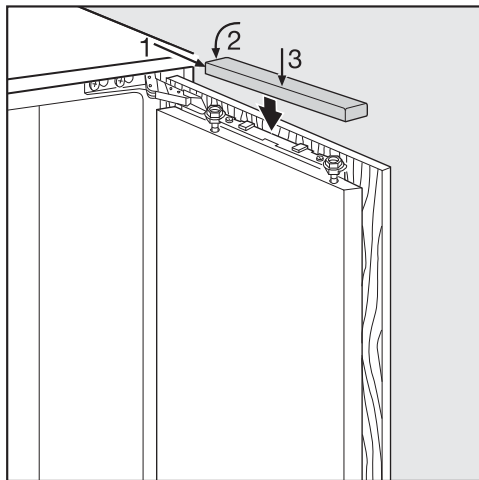
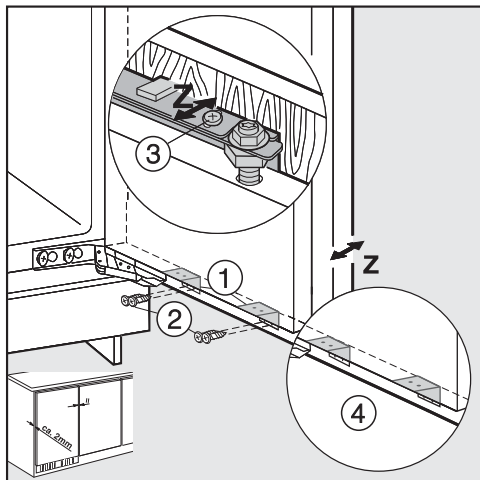

- Attach the appliance door and the furniture door using screws through the fixing brackets ①:

- Drill holes in the furniture door (mark the position of the holes first).
- Screw in the short chipboard screws ② (4 x 14 mm).

- Align the furniture door along the depth plane Z: loosen the screws in the long slots at the top of the appliance door ③ as well as under the appliance door ④. By moving the furniture door, create a gap of 2 mm between the furniture door and the front edge of the niche. Align according to the adjacent furniture doors.

- Close the door, check that it is secured correctly, and align it with adjacent furniture doors.

- Tighten all screws again.

- Fit the cover in position.

To make sure the appliance is correctly installed:

- The door must close properly.
- The door must not touch the housing unit.
- The seal at the top edge of the handle side must fit properly.
- To double check, place a torch in the appliance and close the door. Switch the lights off in the room. If you can see any light shining out from the sides, double check the installation.

Miele Australia Pty. Ltd.

ACN 005 635 398, ABN 96 005 635 398

Miele Head Office Melbourne:

Level 4, 141 Camberwell Road

Hawthorn East, VIC 3123

1300 464 353 (1300 4 MIELE)

info@miele.com.au

www.miele.com.au

Hong Kong, China

Miele (Hong Kong) Ltd.

41/F - 4101, Manhattan Place

23 Wang Tai Road, Kowloon Bay

Hong Kong

Tel.: (852) 2610 1025

Fax: (852) 3579 1404

E-mail: customerservices@miele.com.hk

Website: www.miele.hk

India

Miele India Pvt. Ltd.

1st Floor, Copia Corporate Suites,

Commercial Plot 9,

Mathura Road, Jasola,

New Delhi - 110025

E-mail: customercare@miele.in

Website: www.miele.in

Malaysia

Miele Sdn Bhd

Suite 12-2, Level 12

Menara Sapura Kencana Petroleum

Solaris Dutamas No. 1, Jalan Dutamas 1

50480 Kuala Lumpur, Malaysia

Phone: +603-6209-0288

Fax: +603-6205-3768

Miele Global Headquarters Germany

Miele & Cie. KG, Carl-Miele-Straße 29, 33332 Gütersloh, Federal Republic of Germany

Miele New Zealand Ltd.

IRD 98 463 631

Head Office:

8 College Hill

Freemans Bay, Auckland 1011

0800 464 353 (0800 4 MIELE)

customercare@miele.co.nz

www.miele.co.nz

Singapore

Miele Pte. Ltd.

29 Media Circle

#11-04 ALICE@Mediapolis

Singapore 138565

Tel: +65 6735 1191

Fax: +65 6735 1161

E-mail: info@miele.com.sg

Internet: www.miele.sg

South Africa

Miele (Pty) Ltd

63 Peter Place, Bryanston 2194

P.O. Box 69434, Bryanston 2021

Tel.: (011) 875 9000

Fax: (011) 875 9035

E-mail: info@miele.co.za

Internet: www.miele.co.za

Thailand

Miele Appliances Ltd.

BHIRAJ TOWER at EmQuartier

43rd Floor Unit 4301-4303

689 Sukhumvit Road

North Klongton Sub-District

Vadhana District

Bangkok 10110, Thailand

K 31222 Ui

en – AU, NZ

M.-Nr. 10 841 791 / 00