

Miele

Installation plan

Heat-pump dryer



PDR 508 HP

It is **essential** to read the operating and installation instructions before installation and commissioning.
This prevents both personal injury and damage to the appliance.

en-GB

12 021 380/04

United Kingdom

Miele Co. Ltd., Fairacres, Marcham Road
Abingdon, Oxon, OX14 1TW
Professional Sales, Tel: 0845 365 6608
E-mail: professional@miele.co.uk
Internet: www.miele.co.uk/professional

Australia

Miele Australia Pty. Ltd.
ACN 005 635 398, ABN 96 005 635 398
Level 4, 141 Camberwell Road, Hawthorn East, VIC 3123
Tel: 1300 731 411
Internet: www.miele.com.au/professional
E-mail: professional.sales@miele.com.au

China Mainland

Miele Electrical Appliances Co., Ltd.
1-3 Floor, No. 82 Shi Men Yi Road
Jing' an District, 200040 Shanghai, PRC
Tel: +86 21 6157 3500, Fax: +86 21 6157 3511
E-mail: info@miele.cn, Internet: www.miele.cn

Hong Kong, China

Miele (Hong Kong) Ltd.
41/F - 4101, Manhattan Place
23 Wang Tai Road, Kowloon Bay, Hong Kong
Tel: (852) 2610 1025, Fax: (852) 3579 1404
Email: customerservices@miele.com.hk
Website: www.miele.hk

India

Miele India Pvt. Ltd.
1st Floor, Copia Corporate Suites,
Commercial Plot 9, Mathura Road, Jasola,
New Delhi - 110025
E-mail: customercare@miele.in, Website: www.miele.in

Ireland

Miele Ireland Ltd.
2024 Bianconi Ave., Citywest Business Campus, Dublin 24
Tel: (01) 461 07 10, Fax: (01) 461 07 97
E-Mail: info@miele.ie, Internet: www.miele.ie

Malaysia

Miele Sdn Bhd
Suite 12-2, Level 12
Menara Sapura Kencana Petroleum
Solaris Dutamas No. 1, Jalan Dutamas 1
50480 Kuala Lumpur, Malaysia
Phone: +603-6209-0288
Fax: +603-6205-3768

New Zealand

Miele New Zealand Limited
IRD 98 463 631
8 College Hill
Freemans Bay, Auckland 1011, NZ
Tel: 0800 464 353
Internet: www.miele.com.au/professional
E-mail: professional.sales@miele.com.au

Singapore

Miele Pte. Ltd.
29 Media Circle, #11-04 ALICE@Mediapolis
Singapore 138565
Tel: +65 6735 1191, Fax: +65 6735 1161
E-Mail: info@miele.com.sg
Internet: www.miele.sg

South Africa

Miele (Pty) Ltd
63 Peter Place, Bryanston 2194
P.O. Box 69434, Bryanston 2021
Tel: (011) 875 9000, Fax: (011) 875 9035
E-mail: info@miele.co.za
Internet: www.miele.co.za

United Arab Emirates

Miele Appliances Ltd.
Showroom 1, Eiffel 1 Building
Sheikh Zayed Road, Umm Al Sheif
P.O. Box 114782 - Dubai
Tel. +971 4 3044 999, Fax. +971 4 3418 852
800-MIELE (64353)
E-Mail: info@miele.ae, Website: www.miele.ae



Manufacturer: Miele & Cie. KG
Carl-Miele-Straße 29, 33332 Gütersloh, Germany

Key:



Connection required



Connection optional or required,
depending on model

AL Exhaust air
ASK Condensate drain hose
B Appliance anchoring
EL Electrical connection
F Appliance feet, adjustable
KG Payment system
KGA Payment system connection
KLA Cooling air vent

KLZ Cooling air intake
PA Equipotential bonding
SLA Peak-load connection
APCL SST Box plinth
APCL OB Open plinth
APCL 001 Washer-dryer stacking kit
XKM Communication module
ZL Air intake

All rights reserved.

Appliance dimensions

* The distances between the machine and the wall are recommendations to help make it easier to carry out service work. If installation space is limited, the machine can also be pushed up against the wall.

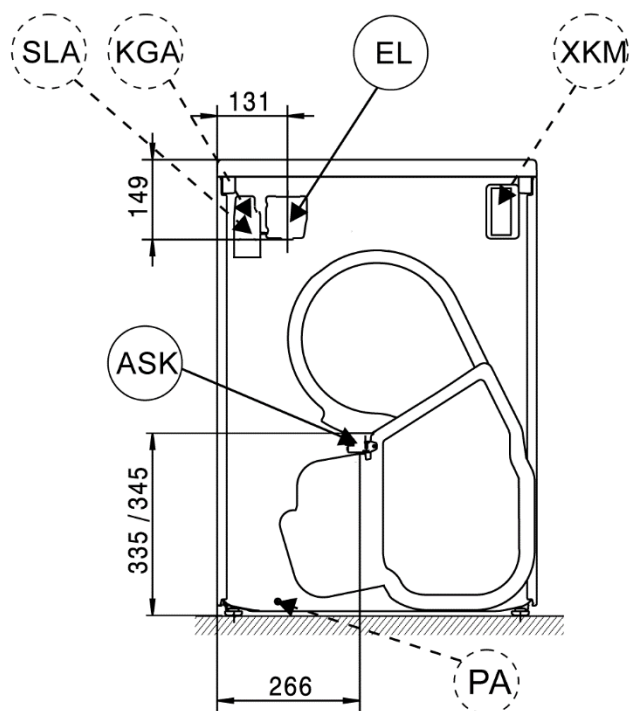
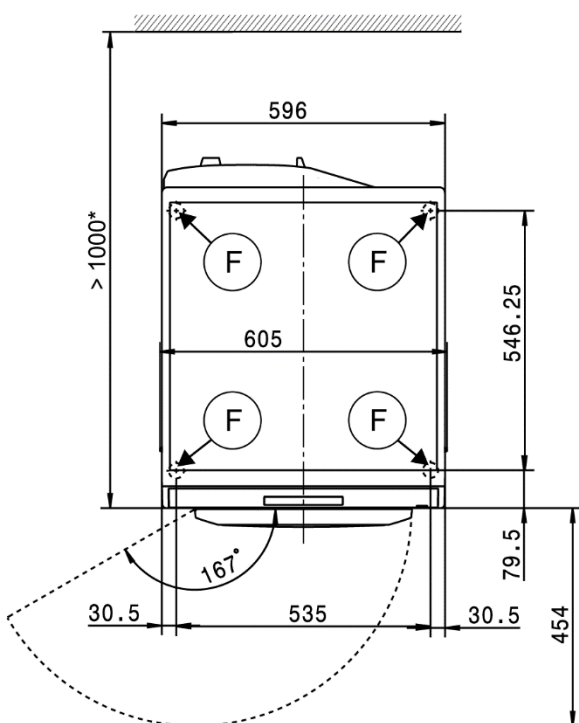
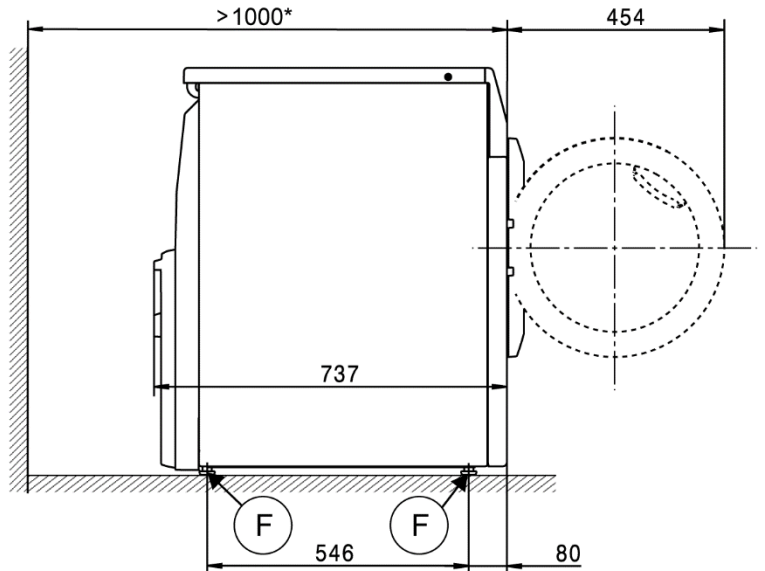
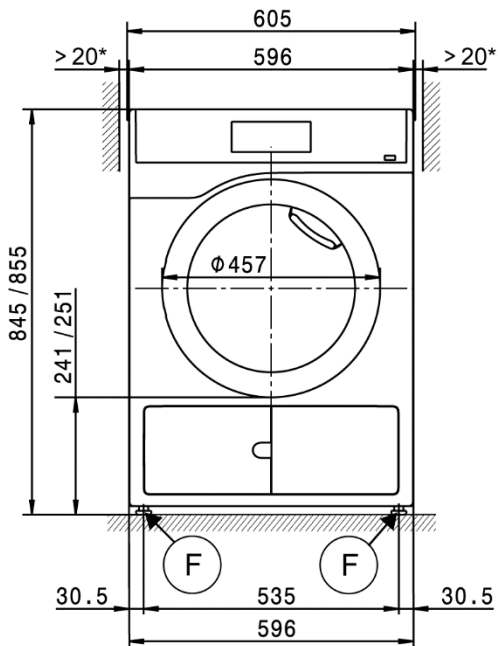

Installation

* The distances between the machine and the wall are recommendations to help make it easier to carry out service work. If installation space is limited, the machine can also be pushed up against the wall.

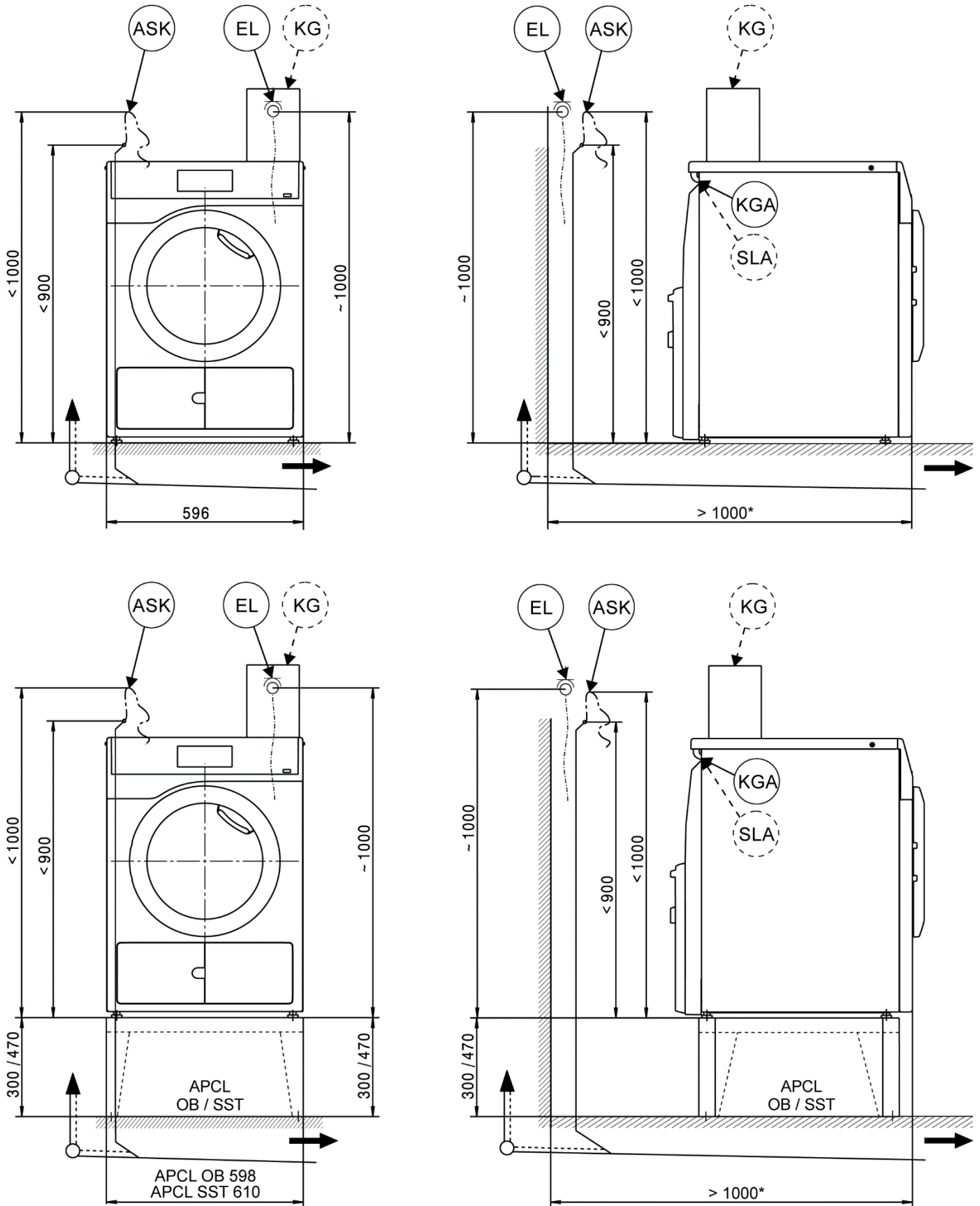

Washer-dryer stack

* The distances between the machine and the wall are recommendations to help make it easier to carry out service work. If installation space is limited, the machine can also be pushed up against the wall.

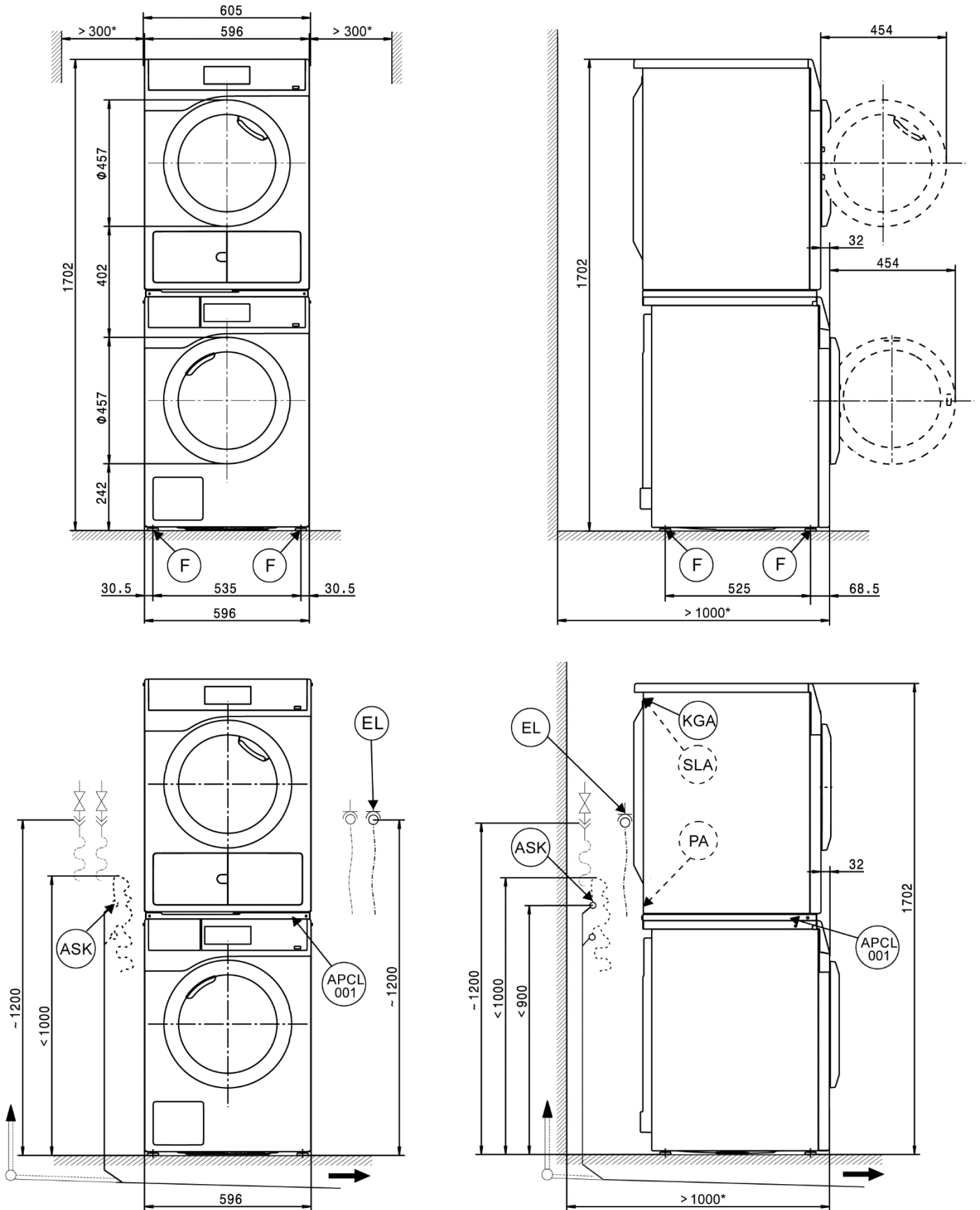

Installation

* The distances between the machine and the wall are recommendations to help make it easier to carry out service work. If installation space is limited, the machine can also be pushed up against the wall.

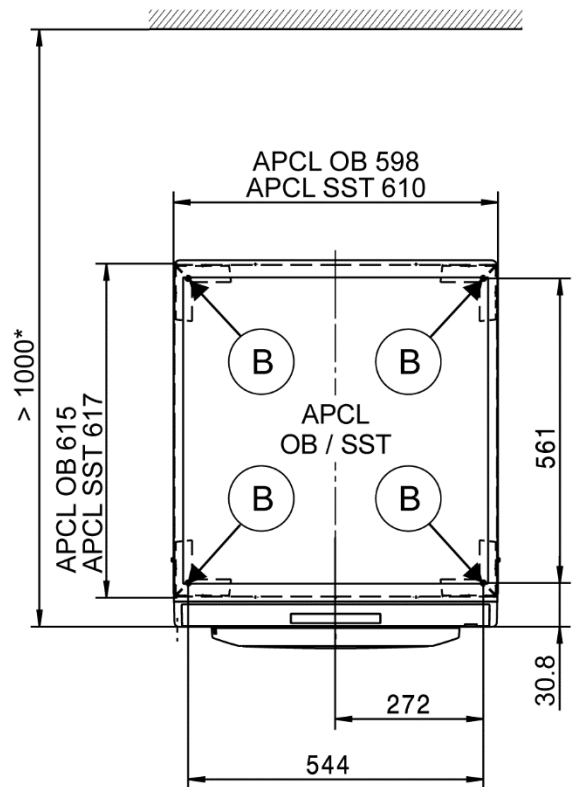
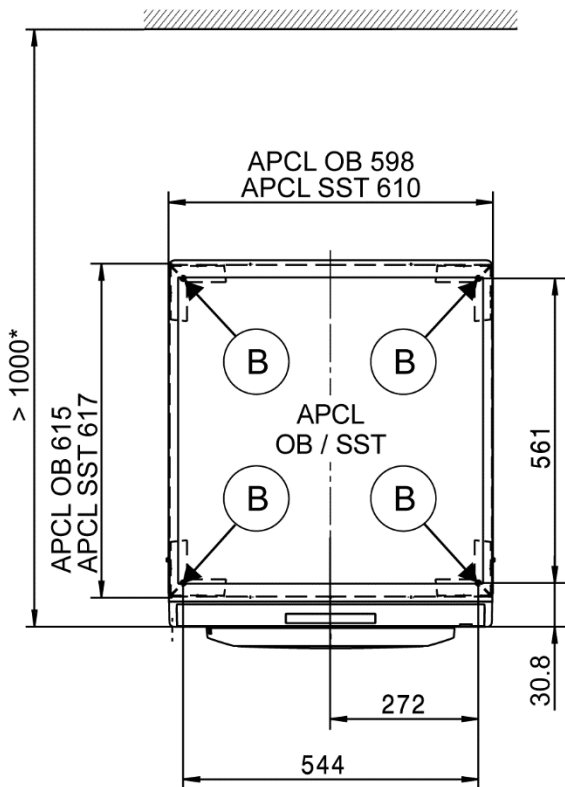
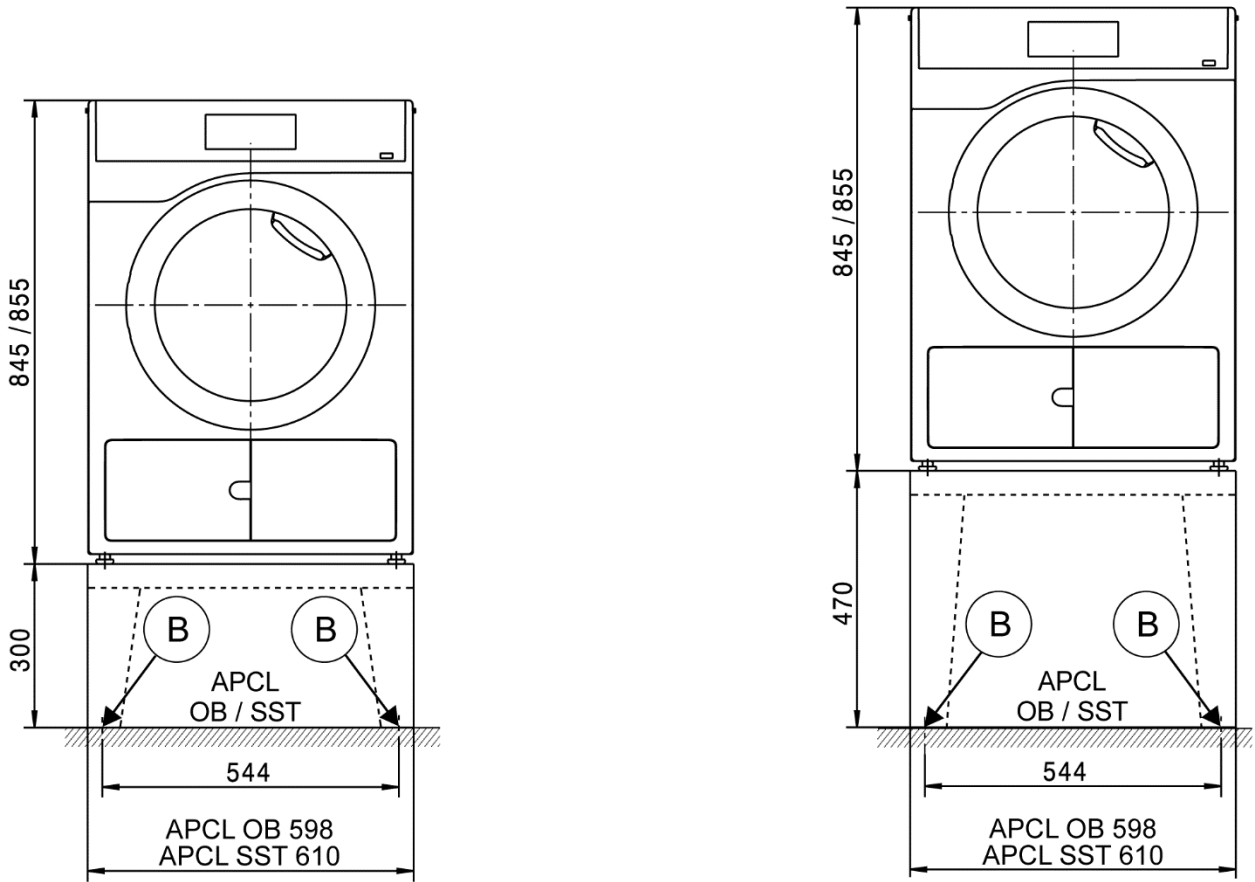

Technical data

		PDR 508 HP
Drying system		Heat pump
Drum volume	l	130
Load capacity	kg	8.0
Door opening diameter	mm	370

Electrical connection (EL)

Standard voltage		1N AC 220–240 V
Frequency	Hz	50
Total rated load	kW	1.44
Fuse rating (B trip rating according to EN 60898)	A	1 x 10
Supply lead min. cross-section	mm ²	3 x 1.5
Supply lead with plug		●
Length of supply lead	mm	2000

Condensate drain hose (ASK)

Max. drainage temperature	°C	70
Max. transient flow rate	l/min	3.6
On-site hose sleeve for drain hose	mm	10 x 30
Drain hose (internal diameter)	mm	10 (DN10)
Length of drain hose	mm	1500
Max. delivery head (from lower edge of appliance)	mm	1000

Equipotential bonding (PA)

Appliance connection (separate kit required)		○
--	--	---

XCI-Box / XCI-AD interface

		●
--	--	---

Peak load/energy management (SLA)

Appliance connection (with XCI-Box)		○
-------------------------------------	--	---

Payment system connection (KGA)

Connection of payment systems (with XCI-Box / XCI-AD)		○
---	--	---

Communication module (XKM)

Communication module XKM 3200 WL PLT		○
--------------------------------------	--	---

Installation on appliance feet (F)

No. of appliance feet	No.	4
Appliance foot, height-adjustable with thread	mm	± 5
Appliance foot diameter	mm	31.7

Anchoring (B)

Anchoring of Miele plinths

Miele plinth installation (fasteners included)		○
Required anchor points	No.	4
Wood screws according to DIN 571	mm	8 x 65
Rawl plugs (diameter x length)	mm	12 x 60

Plinth floor anchoring (to be provided on site)

Appliance installation on on-site plinth (concrete or masonry)		○
Min. plinth installation footprint (W/D)	mm	600/650
Wood screws according to DIN 571	mm	6 x 50
Rawl plugs (diameter x length)	mm	8 x 40

● = standard, ○ = optional, + = only on request, - = not available

Technical data

PDR 508 HP

Appliance data

Overall appliance dimensions (H/W/D)	mm	850/605/777
Casing dimensions (H/W/D)	mm	850/596/737

Site-access dimensions (H/W)

Min. site-access opening (excl. packaging)	mm	900/605
--	----	---------

Installation dimensions

Side gap	mm	20
Recommended side gap – washer-dryer stack	mm	300
Recommended distance to opposite wall from appliance front	mm	1000

Weights and floor loads

Appliance weight (net weight)	kg	68.5
Max. floor load in operation	N	925

Emissions

Sound pressure level (in accordance with EN ISO 11204/11203)	dB(A)	<70
Heat dissipation rate to installation site	W	950

● = standard, ○ = optional, + = only on request, - = not available

Installation and planning notes

Installation requirements

The tumble dryer should only be connected to a power supply provided in accordance with all appropriate local and national legislation and regulations.

In addition, all regulations issued by the appropriate utilities as well as standards relating to occupational safety and all applicable valid regulations and technical standards must be observed.

General operating conditions

Ambient temperature in installation room: +2 °C to +35 °C.

Air drawn in for use in the drying process will be warm when it is expelled back into the room by the tumble dryer. You must therefore ensure that the room is sufficiently ventilated, particularly if the appliance is located in a small room.

Make sure that the room temperature is not too high. If there are other heat-producing appliances in the room in which the dryer is located, make sure the room is well ventilated and switch the other appliances off, if possible.

Otherwise running times and energy consumption could be increased.

Electrical connection

This tumble dryer is supplied with a mains cable and plug ready for connection.

The appliance may only be connected to an electrical system that conforms to the national and local codes and regulations (BS 7671 in the UK).

The tumble dryer should never be connected by an extension cable, e.g. power strips, to avoid the risk of fire.

The data plate indicates the nominal power consumption and the appropriate fuse rating. Compare the specifications on the data plate with those of the electrical power supply.

If the appliance is hard-wired, a dual circuit breaker must be provided on site. When switched off there must be an all-pole contact gap of at least 3 mm in the isolator switch (including circuit breakers, fuses and contactors according to IEC/EN 60947).

The plug connector or isolator switch should be easily accessible at all times. If the appliance is disconnected from the electricity supply, the isolator must be lockable or the point of disconnection must be monitored at all times.

New connections, modifications to the system or servicing of the earthing conductor, including determining the correct fuse amperage, must be carried out by a qualified electrician, as they are familiar with the pertinent regulations and the specific requirements of the electric utility company.

References to cable cross-sections in the technical data refer only to the required mains cable. Please consult relevant local and national regulations when calculating any other wire gauges.

Condensate drain hose

The condensed water is pumped away through the drain hose which is located at the back of the dryer.

The condensate is drained via a drain pump with a 1 m delivery head. For the water to drain freely, the hose must be free of kinks.

In certain situations this tumble dryer must be fitted with a non-return valve (optional accessory). Without a non-return valve, water could flow back into the tumble dryer or be drawn back in and leak out. This can cause damage.

Drainage options:

1. **Direct connection to a plastic drain pipe with a rubber sleeve.**
Use a non-return valve if the end of the hose could possibly become submerged in water.
2. **Connection to a washbasin with a plastic nipple.**
Always use a non-return valve.
3. **Connection to a floor drain (gully).**
Always use a non-return valve.
4. **Directed into a sink or basin.**
Secure the drain hose carefully (e.g. by tying it) to make sure it cannot slip. Otherwise water may escape and cause damage. Use a non-return valve if the end of the hose could possibly become submerged in water.

Equipotential bonding

If necessary, equipotential bonding with good galvanic contact must be guaranteed in compliance with all applicable local and national installation specifications.

Connection material for equipotential bonding must be provided on site or using a kit available from the Miele Customer Service Department.

Peak load/energy management

The tumble dryer can be connected to a peak-load or energy management system using an optional kit.

When the peak-load function is activated, the heating is deactivated. A message appears in the display to inform you of this.

Payment system

The tumble dryer can be fitted with a single-machine payment system as an optional accessory using an optional kit (XCI-Box / XCI-AD).

The programming required for connecting a payment system can be carried out during the initial commissioning process. After initial commissioning, changes may only be carried out by your Miele dealer or the Miele Customer Service Department.

Interface

The appliance can be fitted with an XKM 3200 WL PLT communication module.

This module can be used as a WiFi or LAN interface.

The LAN interface provided via the module complies with SELV (Safety Extra Low Voltage) in accordance with EN 60950. Connected tumble dryers must also comply with SELV. The LAN connection uses a RJ45 connector in accordance with EIA/TIA 568-B.

Installation and anchoring

The appliance must be installed on a perfectly smooth, level and firm surface which is able to withstand the quoted loads.

The floor load created by the appliance is concentrated and transferred to the installation footprint via the appliance feet.

The appliance should be levelled in both directions with the aid of the adjustable feet.

Plinth installation

The tumble dryer can be installed on a plinth (open or box plinth, available as an optional Miele accessory) or on a concrete plinth to be provided on site.

The quality of the concrete and its strength must be assessed according to the appliance load. Ensure that any raised concrete plinth is adequately bonded to the floor below.

Washer-dryer stack

The tumble dryer can be installed as a washer-dryer stack together with a Miele washing machine. A stacking kit (optional accessory) is required for this.

Installation of the stacking kit must be performed by the Miele Customer Service Department or an authorised Miele service technician.

Installing the washer-dryer stack on a Miele plinth is not permitted.