













Operating and installation instructions Freezer



It is **essential** to read these operating and installation instructions before installing and using the appliance. This prevents both personal injury and damage to the appliance.

Contents

Warning and Safety instructions	5
Caring for the environment	17
Installation	18
Location	18
Climate range	18
Installation notes	19
Adjoining cabinets/units	19
Load-bearing capacity of the niche floor	20
Ventilation	20
Door hinging	20
Side-by-side units	21
Specifications for the mains water connection	22
Installation dimensions	23
Dimensions with the appliance door open (opening angle 115°)	25
Dimensions of the furniture front	26
Installing the appliance	27
Before you start	27
Tools required	27
Weight of furniture front	28
Aligning the installation niche	28
Checking the installation niche	29
Before installation	30
Preparing the installation niche	31
Pushing the appliance into the niche	34
Aligning the appliance	35
Securing the appliance in the niche	38
Preparing to install the furniture fronts	40
Securing and aligning the furniture front	43
Securing the covers	47
Securing the plinth ventilation grille and plinth cover	49
Aligning the Ice/Water dispenser	50
Water connection	55
Information about the mains water connection	55
Connecting the appliance to the mains water supply	56
Electrical connection	57
Saving energy	58
Guide to the appliance	60
Main screen	61
Settings mode 	63
Accessories	65
Accessories supplied	65

Optional accessories	65
Using for the first time	66
Before using for the first time	66
Choosing the right Door assistant (Push2open/Pull2open)	66
Miele@home	67
Operating the refrigeration appliance	68
Using for the first time	69
Switching on and off	70
Switching off for longer periods of time	71
Selecting further settings	72
Switching the Keypad lock  /  on or off	72
Switching Eco mode  on or off	72
Carrying out a Self test 	73
Switching on the Door assistant 	73
Switching off the Door assistant 	75
Miele@home	76
Switching off Demo mode 	77
Resetting the settings to their factory default settings 	78
Selecting settings for lighting the Ice/Water dispenser 	80
Switching Sabbath mode  on or off	81
Switching on, switching off, or resetting the Water filter display 	82
The correct temperature	84
Setting the temperature	84
Temperature range	85
Using SuperFreeze	86
Temperature and door alarm	87
Adjusting the interior fittings	89
Moving or removing the adjustable shelves	89
Removing the shelf above the ice cube maker	89
Removing the freezer baskets	90
Freezing and storing food	91
Freezing fresh food	91
Storing frozen food	91
Home freezing	92
Placing food in the freezer	93
Operating the Ice/Water dispenser	95
Switching the Dispenser unit  on	96
Dispensing chilled water	96
Dispensing ice cubes and crushed ice	97

Contents

Switching the Dispenser unit  off	97
Switching the system lock on/off	98
Automatic defrosting	99
Cleaning and care	100
Cleaning agents	100
Before cleaning the appliance	101
Cleaning the interior and accessories	102
Emptying and cleaning the ice cube container	102
Cleaning the drip tray.....	103
Cleaning the door seal.....	103
Cleaning the ventilation gaps	103
Cleaning the water filter (IntensiveClear mesh filter)	104
After cleaning	105
Water filter	106
Problem solving guide	107
Noises	000
Service	119
Contact in case of fault.....	119
Warranty	119
Copyright and licences	120

Warning and Safety instructions

This refrigeration appliance complies with current local and national safety requirements. However, inappropriate use can lead to personal injury and damage to property.

Please read the operating and installation instructions carefully before using the refrigeration appliance for the first time. They contain important information on safety, installation, use and maintenance of the appliance. This is to protect yourself from injury and from damaging your refrigeration appliance.

In accordance with standard IEC 60335-1, Miele expressly and strongly advises that you read and follow all information provided concerning the installation of the refrigeration appliance, as well as safety notes and warnings.

Miele cannot be held liable for injury or damage caused by non-compliance with these instructions.

Keep these instructions in a safe place and pass them on to any future owner.

 Risk of injury and damage due to the refrigeration appliance tipping over.

This appliance is very heavy and can tip forwards when the door is open.

Keep the appliance doors shut until the appliance has been built in and secured in its housing in accordance with the operating and installation instructions.

Warning and Safety instructions

Correct application

▶ This appliance is designed for domestic use and for use in similar environments by guests in hotel or motel rooms, bed & breakfasts and other typical living quarters. This does not include common/shared facilities or commercial facilities within hotels, motels or bed & breakfasts.

This appliance is not suitable for outdoor use.

▶ This refrigeration appliance is intended exclusively for domestic use to store deep-frozen food, to freeze fresh food, to make ice cubes and to dispense drinking water.

Any other usage is not permitted.

▶ This appliance is not suitable for storing and keeping cool medicines, blood plasma, laboratory preparations or similar substances or products. Incorrect use of the appliance for such purposes may cause deterioration of the items stored.

The appliance is also not suitable for use in areas where there is a risk of explosion.

Miele cannot be held liable for damage resulting from incorrect or improper use or operation of the appliance.

▶ This appliance is not intended for use by persons (including children) with reduced physical, sensory or mental capabilities or lack of experience and knowledge, unless they have been given supervision and instruction concerning its use by a person responsible for their safety.

They may only use the appliance unsupervised if its operation has been clearly explained to them and they are able to use it safely and are able to understand and recognise the possible dangers caused by incorrect operation.

Safety with children

- ▶ Young children must not be allowed to use this appliance.
- ▶ Older children may only use the appliance when its operation has been clearly explained to them and they are able to use it safely, recognising the dangers of misuse.
- ▶ Cleaning work may only be carried out by older children under the supervision of an adult.
- ▶ Please supervise children in the vicinity of the appliance and do not let them play with it.
- ▶ The appliance door hinges can cause injury. Keep children away at all times.
- ▶ Danger of suffocation! Children may be able to wrap themselves in packing material (e.g. foil) or pull it over their head with the risk of suffocation. Keep packaging material away from children.

Warning and Safety instructions

Technical safety

▶ The refrigerant circuit has been checked for leaks. The refrigeration appliance complies with all current local and national safety requirements.



▶ Warning: Risk of fire / Flammable materials.

The refrigerant inside the appliance (details on the data plate) is environmentally friendly but flammable.

The use of this refrigerant does, however, sometimes lead to a slight increase in the noise level of the appliance. In addition to the noise of the compressor, you might be able to hear the refrigerant flowing around the system. Unfortunately, these effects cannot be avoided, but they do not affect the performance of the refrigeration appliance.

When transporting and installing the refrigeration appliance, ensure that no parts of the cooling circuit are damaged. Splashes of refrigerant can damage the eyes and leaking refrigerant can ignite.

In the event of any damage:

- Avoid naked flames or anything which creates a spark.
- Disconnect the refrigeration appliance from the mains electricity supply.
- Ventilate the room in which the appliance is located for several minutes.
- Call Miele.

▶ The more refrigerant there is in a refrigeration appliance, the larger the room should be in which it is installed. In the event of a leakage, if the appliance is in a small room, there is the danger of a combustible gas/air mixture building up. For every 8 g of refrigerant, at least 1 m³ of room space is required. The amount of refrigerant in the refrigeration appliance is stated on the data plate inside the appliance.

Warning and Safety instructions

- ▶ To avoid the risk of damage to the appliance, make sure that the connection data (fuse rating, frequency and voltage) on the data plate corresponds to the household supply. Check that this is the case before connecting the appliance. Consult a qualified electrician if in any doubt.
- ▶ The electrical safety of this appliance can only be guaranteed when correctly earthed. It is essential that this standard safety requirement is met. If in any doubt please have the electrical installation tested by a qualified electrician.
- ▶ Temporary or permanent operation with a self-sufficient or non-mains synchronous energy supply system (e.g. isolated networks, back-up systems) is possible. A requirement for the operation is that the energy supply system complies with all current local and national requirements that apply to stand-alone, solar and/or battery systems. The protective measures provided in the installation and in this Miele product must also be assured in their function and operation in isolated operation or in non-mains synchronous operation, or replaced with equivalent measures in the installation.
- ▶ The socket must not be concealed behind the appliance and must be easily accessible so that the appliance can be quickly disconnected from the electricity supply in case of an emergency.
- ▶ If the electrical connection cable supplied is damaged, it must only be replaced by an original spare part to prevent a hazard for the user. Miele can only guarantee the safety of the appliance when original Miele parts are used. For safety reasons, replacement may only be carried out by a suitably qualified specialist or Miele Customer Service.
- ▶ Do not connect the appliance to the mains electricity supply by a multi-socket unit or an extension lead. These do not guarantee the required safety of the appliance (e.g. danger of overheating).
- ▶ If moisture gets into electrical components or into the mains connection cable, it could cause a short circuit. Therefore, do not operate this refrigeration appliance in areas which are exposed to moisture (e.g. in a garage or laundry).
- ▶ This appliance must not be installed and operated in mobile installations (e.g. on a ship).
- ▶ Do not use a damaged appliance. It could be dangerous. Check the appliance for visible signs of damage.

Warning and Safety instructions

- ▶ For safety reasons, this appliance may only be used when it has been fully installed.
- ▶ The appliance must be disconnected from the power supply during installation, maintenance and repair work, and during installation work on the mains water connection. It is only completely isolated from the power supply when:
 - the mains circuit breaker is switched off, or
 - the screw-out fuse is removed (in countries where this is applicable), or
 - it is switched off at the wall socket and the plug is withdrawn from the socket.
- ▶ Unauthorised installation, maintenance and repairs, or a faulty mains water connection can result in considerable danger for the user.
Maintenance and repairs, installation work on the mains water connection, and all repairs on the ice/water outlet must only be carried out by a Miele authorised technician.
- ▶ The manufacturer's warranty will be invalidated if the appliance is not repaired by a Miele authorised technician.
- ▶ Faulty components must only be replaced with genuine Miele original spare parts. Miele can only guarantee the safety standards of the appliance when Miele spare parts are used.
- ▶ This refrigeration appliance is supplied with a special lamp to cope with particular conditions (e.g., temperature, moisture, chemical resistance, abrasion resistance and vibration). This lamp must only be used for the purpose for which it is intended. The lamp is not suitable for room lighting. Replacement lamps may only be replaced by a Miele authorised technician. This refrigeration appliance contains several light sources with at least energy efficiency class F.
- ▶ Miele cannot be held liable for damage caused by a faulty water connection.
- ▶ The ice cube maker must only be connected to a cold water supply.
- ▶ Danger of injury! Ensure that you do not come into contact with moving parts on the dispensing mechanism of the ice cube maker or the heating element on the ice cube maker.

Warning and Safety instructions

▶ In areas which may be subject to infestation by cockroaches or other vermin, pay particular attention to keeping the appliance and its surroundings clean at all times. Any damage caused by cockroaches or other vermin will not be covered by the warranty.

Correct use

▶ This refrigeration appliance is designed for use within specific ambient temperatures (climate range). Do not use it in ambient temperatures for which it is not designed. The climate class is stated on the data plate inside the refrigeration appliance. A lower ambient temperature will cause the compressor to switch off for longer periods, meaning that the refrigeration appliance is unable to maintain the required temperature.

▶ To ensure proper air flow in and out of the appliance, the ventilation gaps in the appliance and built-in structure must not be covered or blocked in any way. This would also increase the energy consumption and could cause damage to the appliance.

▶ If storing food which contains a lot of fat or oil in the appliance or the appliance door, make sure that it does not come into contact with plastic components as this could cause stress cracks or break the plastic. Make sure that no fat or oil leaks onto the plastic parts of the appliance.

▶ Risk of fire and explosion! Do not store any explosive materials or products containing flammable propellants (e.g. spray cans) in the refrigeration appliance. Electrical components can cause flammable mixes of gases to ignite.

▶ Danger of explosion! Do not operate any electrical equipment (e.g. an electric ice cream maker) inside the appliance. Danger of sparking and explosion.

▶ Risk of injury and damage! Do not store cans or bottles containing carbonated drinks or liquids which could freeze in the freezer zone. They could burst.

▶ Risk of injury and damage! When chilling drinks in the freezer zone, make sure that bottles are not left in for more than one hour. Otherwise they could burst, causing injury or damage.

▶ Danger of injury! Never handle frozen food or the metal parts of the appliance with wet hands. Your hands may freeze to the frozen food or to the metal.

Warning and Safety instructions

- ▶ Danger of injury! Do not take ice cubes out with your bare hands and never place ice cubes or ice lollies in your mouth straight from the freezer zone. The very low temperature of the frozen goods can cause frost burn to the lips and tongue.
- ▶ Do not refreeze thawed or partially thawed food. Defrosted food should be used up as quickly as possible, as food soon loses its nutritional value and goes off. Defrosted food may only be refrozen after it has been cooked.
- ▶ Food stored for too long may present a risk of food poisoning. Storage times will depend on several factors, including the freshness and quality of the food, as well as the temperature at which it is stored. Follow the instructions given on the food manufacturer's packaging regarding storage conditions and use-by dates.

Accessories and spare parts

- ▶ Only use original Miele accessories. Using spare parts or accessories from other manufacturers will invalidate the warranty, and Miele cannot accept liability.
- ▶ Miele will guarantee to supply functional spare parts for a minimum of 10 years and up to 15 years following the discontinuation of your refrigeration appliance.

Warning and Safety instructions

Cleaning and care

- ▶ Do not use any oils or grease on the door seals, as these will cause the seals to deteriorate and become porous with time.
- ▶ Do not use a steam cleaning appliance to clean this appliance. Steam could reach the electrical components and cause a short circuit.
- ▶ **Warning:** Do not use any mechanical tools or other types of aid which are not recommended by the manufacturer to accelerate the defrosting process.
- ▶ Sharp edged or pointed objects will damage the evaporator, causing irreversible damage to the appliance. Do not use sharp edged or pointed objects to
 - remove frost and ice, or accelerate the defrosting process,
 - separate frozen foods and remove ice trays.
- ▶ Never place electric heaters or candles in the appliance to defrost it. These can damage the plastic parts.
- ▶ Do not use defrosting sprays or de-icers, as they might contain substances which could damage the plastic parts or which could cause a build-up of gases and pose a danger to health.

Transport

- ▶ To avoid damage to the appliance, always transport it upright and in its packaging.
- ▶ Risk of injury and damage! The refrigeration appliance is very heavy and must be transported by two people.

Disposal of your old appliance

- ▶ Children playing could become trapped in the refrigeration appliance and could suffocate.
 - Remove the appliance door(s).
 - Remove the drawers.
 - Leave the adjustable shelves in the refrigeration appliance so children cannot climb inside.
 - If your old refrigeration appliance has a door lock, destroy it. This way you will prevent the risk of playing children accidentally locking themselves in and endangering their lives.
- ▶ Risk of electric shock!
 - Cut the electrical plug off the power supply cord.
 - Cut the power supply cord off the old appliance.

Dispose of the electrical plug and power supply cord separately from the old appliance.

- ▶ During and after disposal, make sure that the refrigeration appliance is not placed near petrol or other flammable gases and liquids.

- ▶ Risk of fire due to escaping oil or refrigerant!

The refrigerant and oil inside the appliance are flammable. In high enough concentrations, escaping refrigerant or oil may ignite if they come into contact with an external heat source.

During disposal, make sure that the cooling circuit is not damaged in order to prevent refrigerant and oil escaping in an uncontrolled manner (see the data plate for details of the refrigerant).

- ▶ Splashes of coolant can damage the eyes. Be careful not to damage any part of the pipework whilst awaiting disposal, e.g. by
 - puncturing the refrigerant channels in the condenser,
 - bending any pipework, or
 - scratching the surface coating.

Warning and Safety instructions

Symbol on the compressor (depending on model)

This information is only relevant for recycling. There is no risk during normal operation.



- ▶ The oil in the compressor can be fatal if swallowed or if it penetrates the airways.

Disposal of the packing material

The transport and protective packaging has been selected from materials which are environmentally friendly for disposal, and can normally be recycled.

Recycling the packaging reduces the use of raw materials in the manufacturing process and also reduces the amount of waste in landfill sites.

Ensure that any plastic wrappings, bags etc. are disposed of safely and kept out of the reach of babies and young children. Danger of suffocation.

Only for Australia: Note for installer: Expanded polystyrene (EPS) packaging included. Please retain and dispose of EPS packaging responsibly. For further information, please contact Miele.

Disposing of your old appliance

Electrical and electronic appliances contain many valuable materials. They also contain certain materials, compounds, and components which were essential for their correct functioning and safety. These could be hazardous to human health and to the environment if disposed of with general waste or if handled incorrectly. Please do not, therefore, dispose of your old appliance with your household waste.



Take care not to damage your refrigeration appliance before or during disposal in an authorised, environmentally friendly manner. This is to ensure that refrigerant in the cooling circuit and oil in the compressor is contained, and will not leak into the environment.

Please dispose of it at your local community waste collection/recycling centre for electrical and electronic appliances, or contact Miele. You are also responsible for deleting any personal data that may be stored on the appliance prior to disposal. You should remove any old batteries which are not securely enclosed by the appliance and remove any lamps without destroying them, where this is possible. These must be taken to a suitable collection point where they can be handed in free of charge. Please ensure that your old appliance presents no danger to children while being stored awaiting disposal.

Installation

Location

This appliance should be installed in a dry, well-ventilated room.

When deciding where to install your refrigerator, please bear in mind that it will use more energy if installed near a heater, cooktop or other appliance that gives off heat. Direct sunlight should also be avoided.

The higher the room temperature, the longer the compressor will run and the higher the energy consumption will be.

Please note the following when installing the appliance:

- The mains socket must not be located directly behind the appliance and must be easily accessible.
- The plug and the power cable must not touch the rear of the refrigeration appliance as they could be damaged by vibrations from the appliance.
- Nor should other appliances be plugged into a socket located directly behind this appliance.

If installation near a heat source is unavoidable, observe the following minimum distances between the appliance and the heat source:

- at least 3 cm to electric or gas stoves
- at least 30 cm to oil or coal stoves.

If it is not possible to observe these minimum distances, an insulation plate must be installed between the refrigeration appliance and the heat source.

Climate range

This refrigeration appliance is designed for use within specific ambient temperatures (climate range). Do not use it in ambient temperatures for which it is not designed. The climate class is stated on the data plate inside the refrigeration appliance.

Climate range	Ambient temperature
SN	10 to 32 °C
N	16 to 32 °C
ST	16 to 38 °C
T	16 to 43 °C
SN-ST	10 to 38 °C
SN-T	10 to 43 °C

A lower ambient temperature leads to the compressor switching off for longer periods. This can cause the internal temperature in the appliance to rise with the risk of food deteriorating and going off.

 Risk of damage due to high humidity.

In environments with high humidity, condensation can build up on external appliance panels, which can cause corrosion.

Install the refrigeration appliance in a dry and/or air-conditioned room with sufficient ventilation.

After installation, make sure that the appliance door closes properly, the ventilation gaps are not covered and that the refrigeration appliance has been installed in accordance with the operating and installation instructions.

Installation notes

 Danger of damage and injury due to the appliance tipping over!

This refrigeration appliance is very heavy and can tip forwards when the door(s) is/are open.

Keep the appliance door(s) shut until the appliance has been built in and secured in its housing in accordance with these operating and installation instructions.

Due to the size and weight of the appliance, installation must be carried out by two people.

Adjoining cabinets/units

The appliance is screwed to the adjoining cabinets/units to the side and above. For this reason, it is essential that all cabinets/units are fixed to the ground or wall.

Installation

Load-bearing capacity of the niche floor

To ensure the safe installation of the appliance and to guarantee its correct functioning, the floor of the niche where the appliance is to be installed must be smooth and even.

It must be made from strong, rigid material.

Because the appliance is extremely heavy when fully loaded, it is essential that the floor it stands on is able to bear its weight. If necessary, seek the advice of an architect or construction expert.

When fully loaded, the approx. weight of the appliance is:

F 2671 Vi

348 kg

Ventilation

 Risk of fire and damage due to insufficient ventilation.

If the refrigeration appliance is not ventilated sufficiently, the compressor will run more frequently and for longer periods.

This will result in increased energy consumption and a higher operating temperature of the compressor. This, in turn, can result in damage to the compressor.

Please ensure that there is adequate ventilation around the appliance.

It is essential to observe the required ventilation gaps. The ventilation gaps must not be covered or blocked in any way.

Door hinging

The appliance is supplied with fixed hinges. The door hinge cannot be changed.

Side-by-side units

This appliance can be installed side by side with another refrigeration appliance. The following overview will show you which side-by-side installation options you have with your refrigeration appliance.

Depending on the installation situation, you may need the side-by-side installation kit (see “Accessories - Optional accessories”).

Instructions for installing appliances side by side can be found in the side-by-side installation kit installation instructions.

... with partition wall

The wall **a** between the side-by-side refrigeration appliances must be **at least 16 mm** thick.

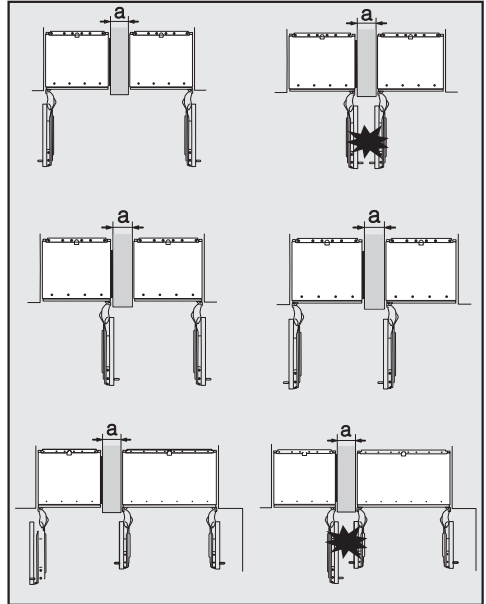

If the door hinges of the appliances are next to each other, you must take into account the thickness of the cabinet fronts and door handles so that the appliance doors do not collide and become damaged if they are opened at the same time.

The appliances are secured individually in their niche using the supplied installation material.

If the partition wall **a** is **between 16 mm and 160 mm**, you will need the side panel heater from the side-by-side installation kit to prevent condensation from forming and any resulting damage.

Installation

When planning installation niches, please note that the niche into which the refrigeration appliance with the side panel heater is installed must be **4 mm** wider (see “Installation – Installation dimensions”).

If the partition wall **a** is **thicker than 160 mm**, you do not need the side-by-side installation kit, nor the side panel heater.

... without partition wall

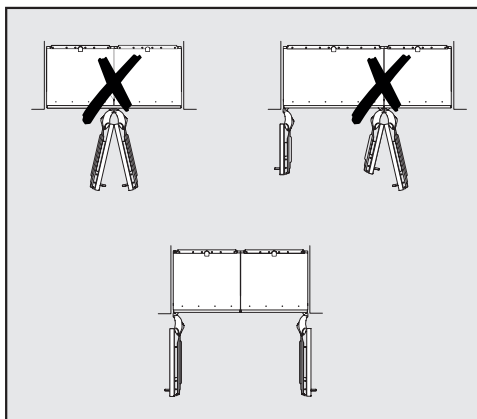

If the appliances are to be installed next to each other without a partition wall between them, they will need to be joined together with the side-by-side installation kit. In addition, you must install the side panel heater to prevent condensation from forming and any resulting damage.

Specifications for the mains water connection

- Connection to the water supply must comply with the applicable regulations in the country where the appliance is being installed.
All units and systems used to supply water to the refrigeration appliance must also comply with the applicable regulations in the respective country.
- The appliance may only be connected to the water supply by a suitably qualified technician.
- The quality of the water used must conform to the requirements for drinking water in the country where the refrigeration appliance is being used.
- Connect the stainless steel hose to the fresh water supply and avoid connection to a water supply in which the water might stagnate.
- The appliance is only suitable for connection to a cold water line.
- The water pressure must be between 200 kPa and 800 kPa (2 and 8 bar).
- A tap must be provided between the stainless steel hose and the mains water supply to ensure that the water supply can be shut off if necessary.
- The tap should be easily accessible after the appliance has been built in.

Installation dimensions

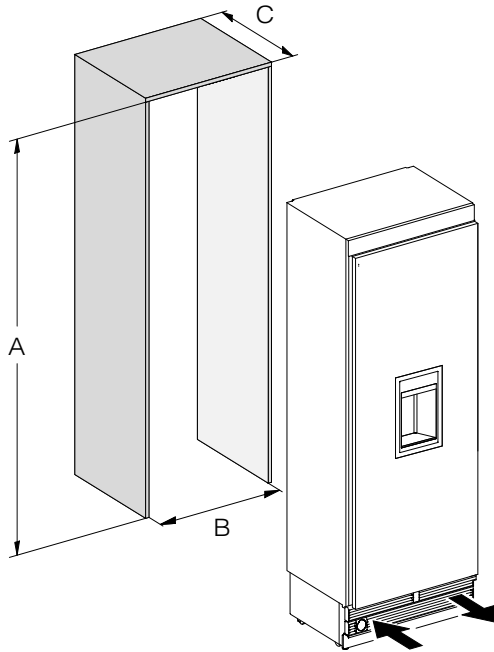

	A	B	°C
F 2671 Vi	2134 – 2164 mm	610 mm	610 mm + furniture front (19–38 mm)

Installation

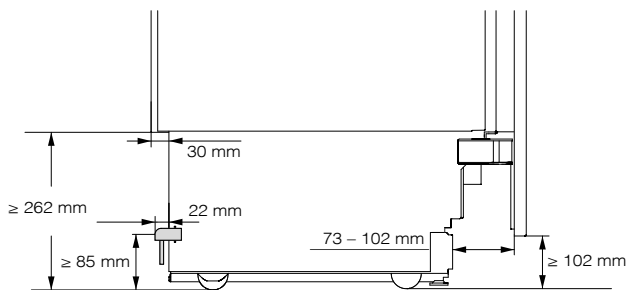

Side view

Dimensions with the appliance door open (opening angle 115°)

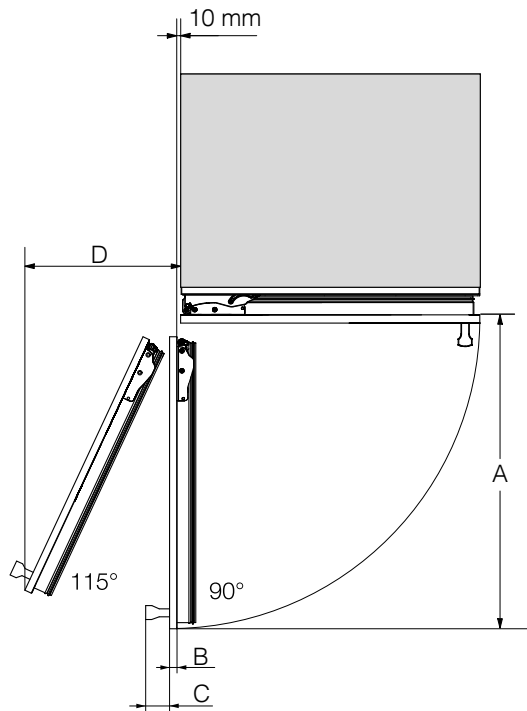

	A	B*	C*	D (with a furniture front of 19 mm)
F 2671 Vi	677 mm	Furniture front (19–38 mm)	Door handle	296 mm

* The dimensions of the furniture front and the door handle vary depending on the design of the kitchen.

The opening angle of the appliance door must not be limited to 90° because otherwise the freezer baskets and ice cube container cannot be removed.

Installation

Dimensions of the furniture front

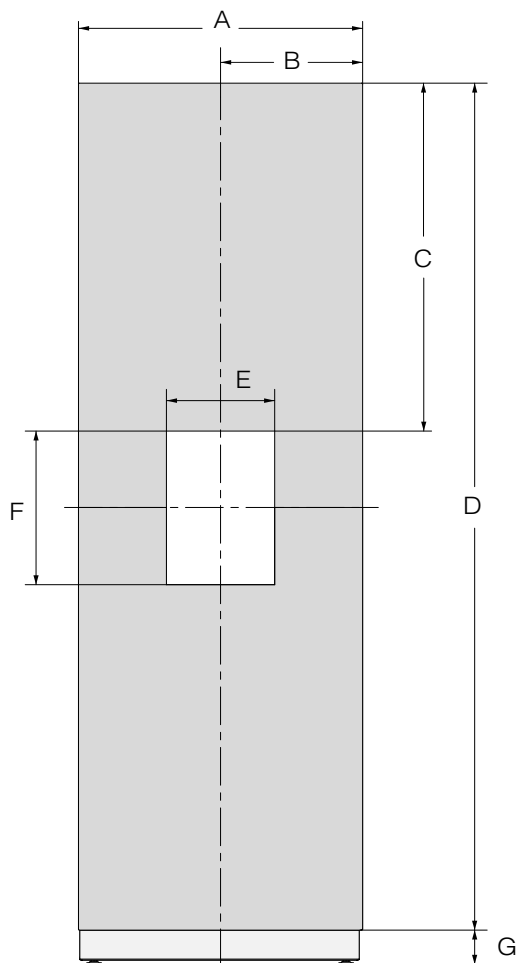

	A	B	°C	D	E	F	G
F 2671 Vi	604 mm	302 mm	830.5 mm	2029 mm	230 mm	368 mm	≥ 102–132 mm

Installing the appliance

Before you start

It is essential to read these operating and installation instructions carefully before starting to install the appliance.

The refrigeration appliance should be installed by a suitably qualified and competent installer in accordance with these operating and installation instructions. Safe operation of the appliance is only assured if it has been installed and connected in accordance with these operating and installation instructions.

 Danger of damage and injury due to the appliance tipping over!

This appliance is very heavy and can tip forwards when the door is open.

Keep the appliance door shut until the appliance has been built in and secured in its niche in accordance with these operating and installation instructions.

Due to the size and weight of the appliance, installation **must be carried out by two people**.

Tools required

- Cordless drill
- TX 20 screwdriver
- Hammer drill
- Drill bits in various sizes, depending on materials
- Hammer
- Open-end spanner
- Ratchet wrench, attachment: 8 mm socket
- Adhesive tape
- Utility knife
- Pipe wrench
- Spirit level
- Tape measure
- Pencil
- Try square

Other

- Step ladder
- Hand trolley

Installation

Weight of furniture front

Before fitting a furniture front, ensure that its weight does not exceed the maximum permitted weight:

Refrigeration appliance	Max. weight of furniture front
F 2671 Vi	71 kg

 Risk of damage due to a furniture front that is too heavy.

Fitting a furniture front which is heavier than the maximum permitted weight could damage the hinges. Among other things, this damage can lead to functional impairments.

Before fitting a furniture front, ensure that its weight does not exceed the maximum permitted weight.

Aligning the installation niche

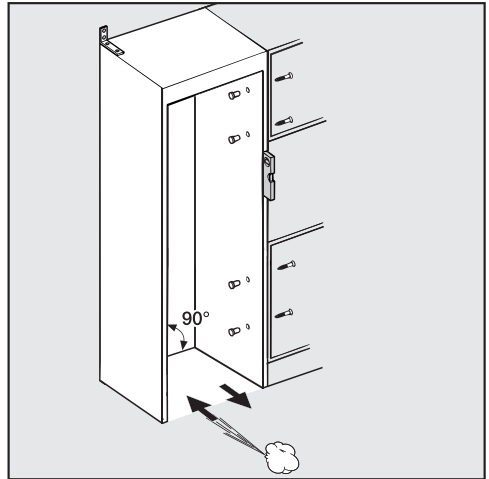

The installation niche must be carefully aligned using a spirit level before installing the appliance. The niche corners must be at 90° angles to each other, otherwise the furniture panels will not sit straight on all four corners of the installation niche.

Checking the installation niche

- Check the installation dimensions (see "Installation - Building-in dimensions").
- Check the position of the electrical connection. The length of the mains connection cable is 3 m.

The electrical socket must not be concealed behind the appliance and must be easily accessible in an emergency.

- Check the position of the mains water connection. The available length of the stainless steel hose is approx. 2 m.

The tap must not be concealed behind the appliance and must be easily accessible in an emergency.

- Check the surroundings for possible collisions (see "Installation - Dimensions with appliance door open").
- Install the appliance in a stable, solid installation niche, positioned on an even and level floor.
- Also check the installation niche for the following criteria:
 - The side panels of the installation niche must be even.
 - The surrounding walls of the niche must be at least 16 mm thick.
 - The surrounding walls must be securely fixed to the floor or wall.
 - Shortened side walls must be at least 100 mm thick.

Installation

Before installation

- Before installation, remove any accessories from the back of the appliance.

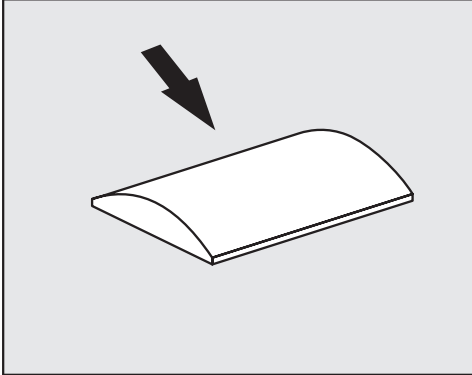

- To protect the floor when installing the appliance, secure an off-cut of flooring (e.g. linoleum) or similar material to the floor in front of the installation area.

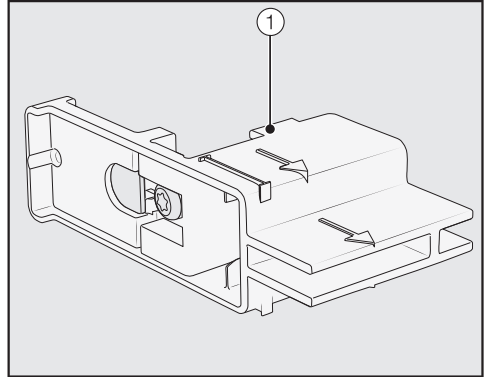

⚠ Risk of damage due to insufficient ventilation.
If the refrigeration appliance is not sufficiently ventilated, this may cause mould to form and, in the long term, lead to damage to the outside of the refrigeration appliance and in the installation niche.

Do not remove the spacers from the outside of the appliance under any circumstances.

Do not compress the spacers under any circumstances.

The spacers guarantee the necessary distance between the refrigeration appliance and the installation niche.

- Check the refrigeration appliance for transport damage.

Do not install a damaged refrigeration appliance.

- Check that all parts at the back of the appliance are unhindered.

- Do **not** remove the installation aids ① from the appliance door. These will be required later for aligning the appliance in the building-in niche.

⚠ Danger of damage and injury due to the appliance tipping over!

As soon as you unscrew the brackets that fix the refrigeration appliance to the pallet, the appliance is no longer secured.

Due to its weight and size, the refrigeration appliance **must be installed by two people**.

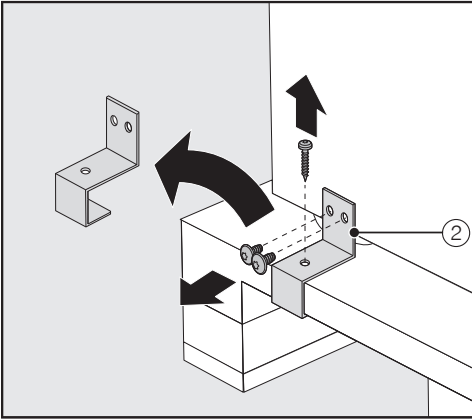

- Unscrew the fixing brackets ②.
- With the help of several people as required, carefully lift the appliance from the pallet, starting with the back of the appliance.

⚠ Risk of damaging the floor due to the load.

Moving the refrigeration appliance may damage your floor.

Move the appliance carefully on floors that are sensitive to scratching.

As soon as you have set the appliance upright, you can move it using the rollers on the bottom.

Preparing the installation niche

⚠ Danger of damage and injury due to the appliance tipping over!

This refrigeration appliance is very heavy and can tip forwards when the door is open.

The housing unit must be secured to the wall behind it and/or above it with several screws. Only this will prevent the appliance from tipping over after being installed.

In addition, use the anti-tip brackets provided to secure the housing unit.

The parts required for installation of the appliance are supplied with the appliance. The plastic bags supplied are marked with letters for easy identification.

- Please take note of these letters during the individual assembly steps and use the applicable plastic bag with the required installation material.

Installation

The anti-tip brackets prevent the refrigeration appliance from tipping. The anti-tip brackets are also used to fix the housing unit securely to the surrounding walls.

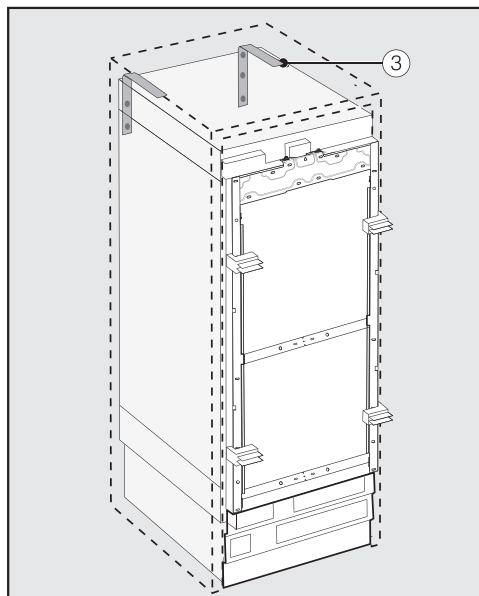

- Use 2 anti-tip brackets ③ for each individual appliance or 4 anti-tip brackets for each (side-by-side) combination of 2 appliances.
- Position the anti-tip brackets ③ on the left and right side of the installation niche.

Depending on the subsequent adjustment of the feet, the anti-tip brackets are positioned 2134–2164 mm from the floor of the niche.

 Risk of injury and damage due to the refrigeration appliance tipping over.

If the anti-tip brackets are fixed too high, they cannot be used to secure the refrigeration appliance.

The height between the anti-tip brackets and the top of the refrigeration appliance must not exceed 8 mm.

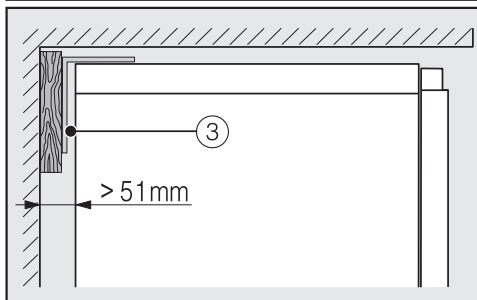
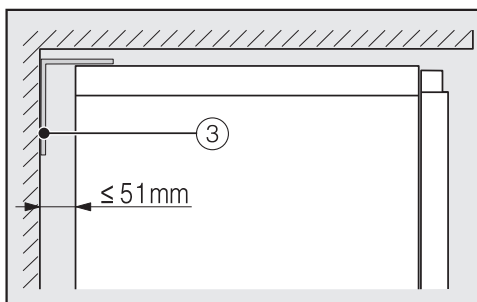

- Make sure that the gap between the refrigeration appliance's rear wall and the installation niche does not exceed 51 mm.
- Place a wooden wedge behind the anti-tip brackets ③ if necessary.
- While holding the anti-tip brackets in place, mark the drill holes on the rear wall of the installation niche.



The accessory pack supplied contains fastening screws for various applications/materials:

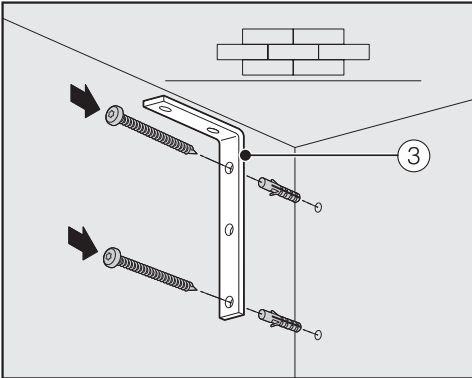

Securing to a concrete wall

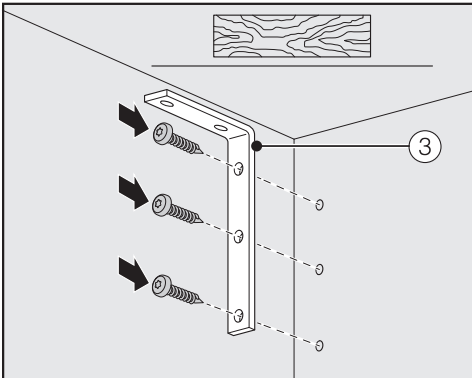

Securing to a wooden wall

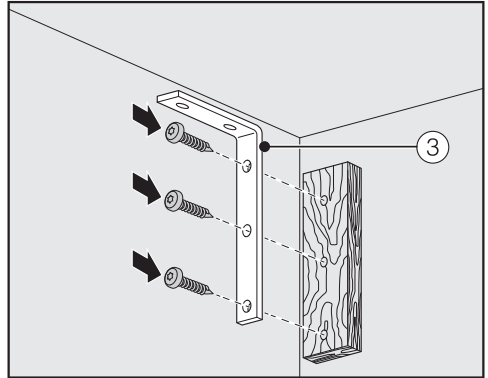

Securing with a wooden wedge

- Secure the housing unit to the wall behind it and/or above it as required using the anti-tip brackets ③.
- Connect the refrigeration appliance to the mains water supply (see "Installation - Water connection").

Installation

Pushing the appliance into the niche

Push the appliance into the niche, taking care not to damage the electrical and mains water connections.

If you are installing several refrigeration appliances side by side, secure the appliances to one another now (see the instructions for the side-by-side installation kit).

- To ensure that the refrigeration appliance can then be aligned correctly, the plinth ventilation grille must be removed from the appliance plinth:

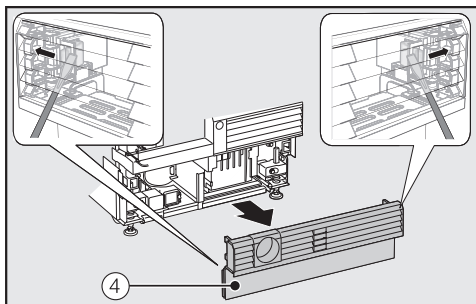

- Carefully guide a flat-head screwdriver through the plinth ventilation grille ④ on both sides and use it to push the internal plastic latches outwards to release the plinth ventilation grille.
- Place the plinth ventilation grille to one side.

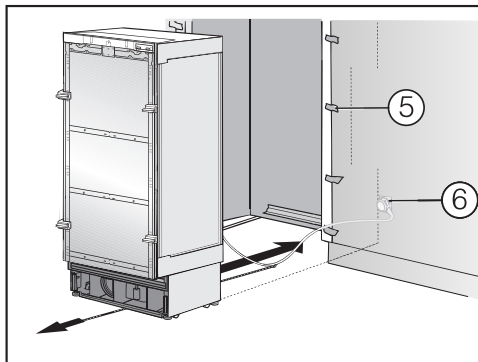

- Affix edge protection ⑤ to the adjacent furniture fronts.
- Insert the plug connector at the back of the appliance (see "Installation - Electrical connection").
- Insert the plug ⑥ into the electrical socket.

The electrical socket should not be concealed behind the appliance and must be easily accessible in an emergency.

⚠ Do not locate multiple portable socket-outlets or portable power supplies at the rear of the appliance.

⚠ Risk of damage due to electrical overload.

If the refrigeration appliance is electrically overloaded, this can cause a short circuit and thus damage your appliance.

When you install appliances side by side, each refrigeration appliance must have its own separate electrical socket.

Useful tip: Secure the mains connection cable to prevent it becoming caught: tie a piece of string to the middle of the cable and as the refrigeration appliance is being pushed into the niche, pull the cable forward underneath the appliance.

- Carefully push the refrigeration appliance into the niche.

 Ensure the cable is not trapped or damaged.

- If the refrigeration appliance cannot be pushed into the niche (because the floor is uneven, for example), unscrew the rear feet slightly (see "Installation - Aligning the appliance") and slide the appliance into the niche.
- Remove the edge protection  from the adjacent furniture fronts.

Aligning the appliance

The installation aids  on the appliance door provide assistance with the alignment of the refrigeration appliance in the installation niche.

The installation aids are suitable for a furniture front thickness of 19 mm or 38 mm.

- Align the appliance with adjacent furniture fronts as described below.

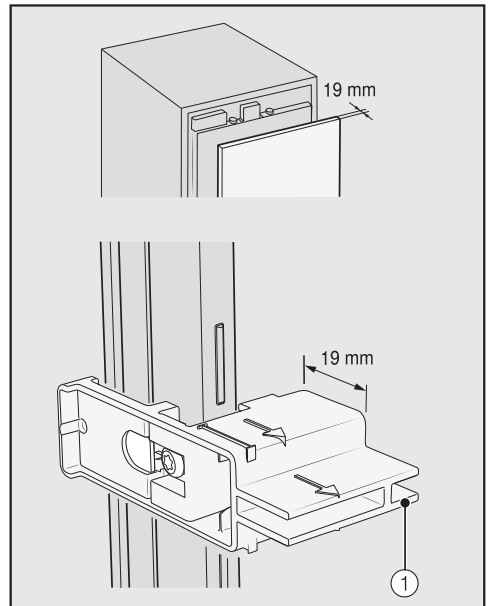

Furniture front thickness of 19 mm

Installation

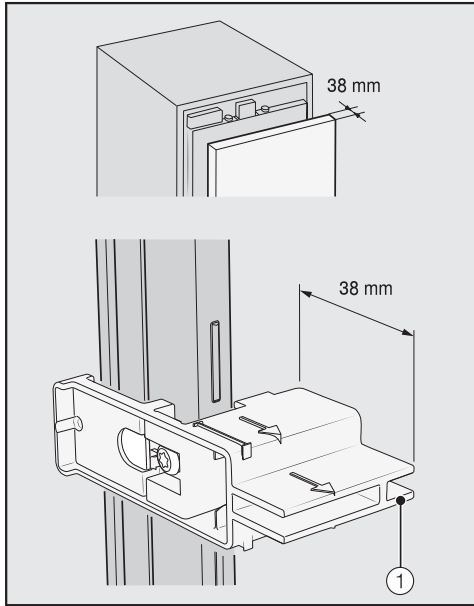

Furniture front thickness of 38 mm

The front and rear feet are height-adjustable and can all be adjusted from the front of the appliance.

 Risk of damage due to incorrect adjustment of the feet.

The foot adjustment can be damaged by using an electric screwdriver.

Always adjust the front and rear feet by hand.

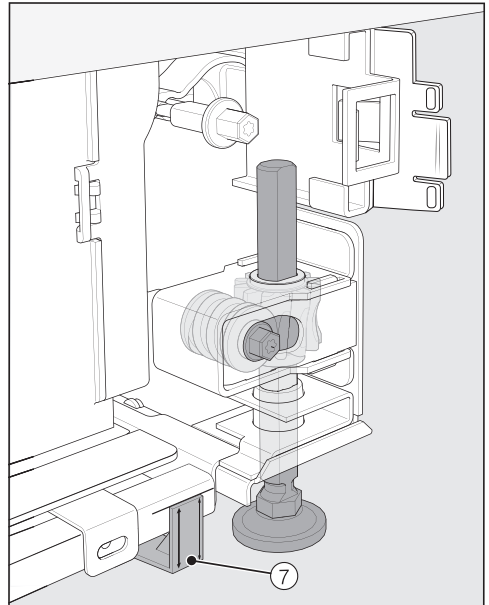

- Position the spacers ⑦ supplied on both sides at the markings next to the adjustable feet in front of the appliance.

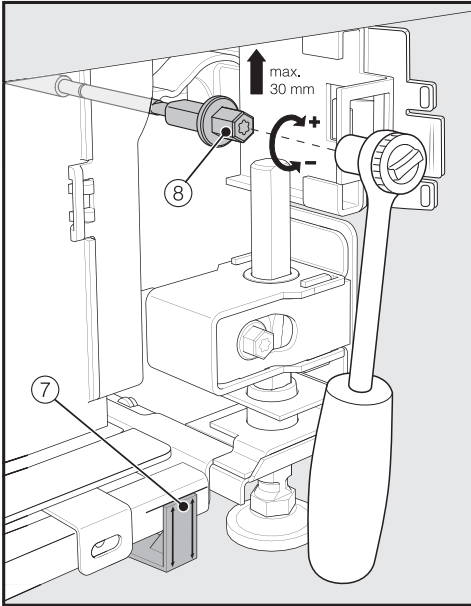

- Adjust the rear feet with a ratchet (attachment: 8 mm socket) or a TX 20 screwdriver ⑧.

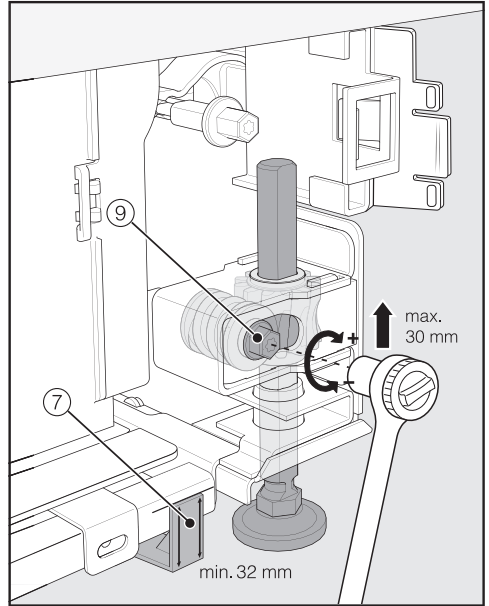

- Adjust the front feet with a ratchet (attachment: 8 mm socket) or a TX 20 screwdriver ⑨.

Useful tip: Proceed carefully when adjusting the feet, alternating between the left and right feet.

Installation

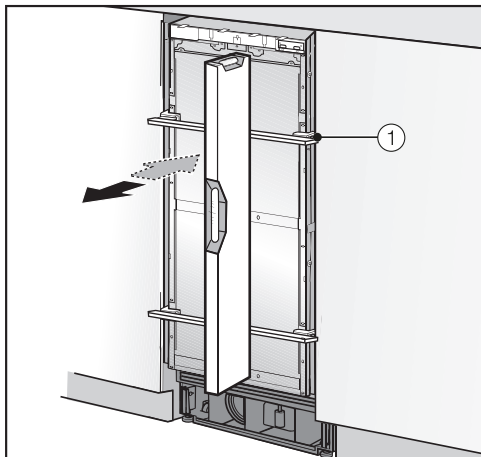

- Place a spirit level across the installation aids ① on the appliance door to check the appliance's alignment.
- Unscrew the feet ⑧ and ⑨ on both sides at least until the marking on the base has reached the minimum specified distance of 32 mm on the spacer ⑦. The standard dimension of 32 mm relates to a niche height of 2134 mm.

It is important to adjust the feet to a height of at least 32 mm in order to ensure the ventilation of the refrigeration appliance via the base.

 Risk of damage if the feet are adjusted too much. The rear adjustable feet can be damaged. Unscrew the feet **only until** the marking on the plinth is aligned to a maximum of 62 mm (max. niche height of 2164 mm).

- Check the alignment of the appliance again using the installation aids ① and the spirit level.

Securing the appliance in the niche

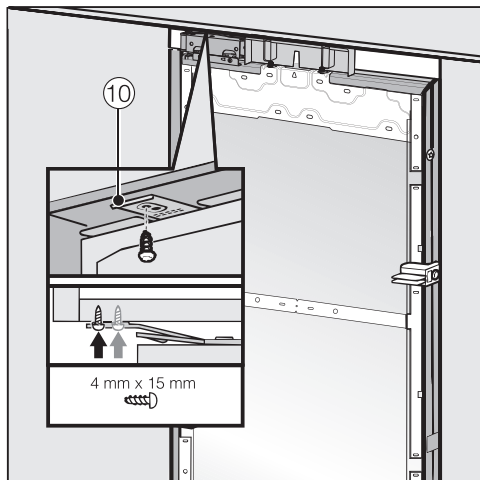

- Screw the lugs of the fixing plate ⑩ into the cabinets/units above the appliance.

If it is not possible to secure the appliance at the top, it can be attached to the niche with the side mounting brackets:

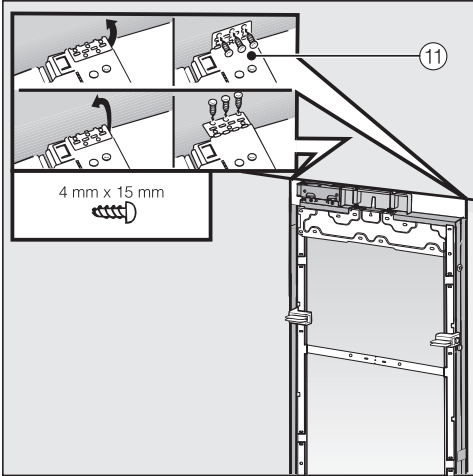

- Fold out the side mounting brackets (11).
- Secure the side mounting brackets (11) with the screws provided.

- Open the appliance door.

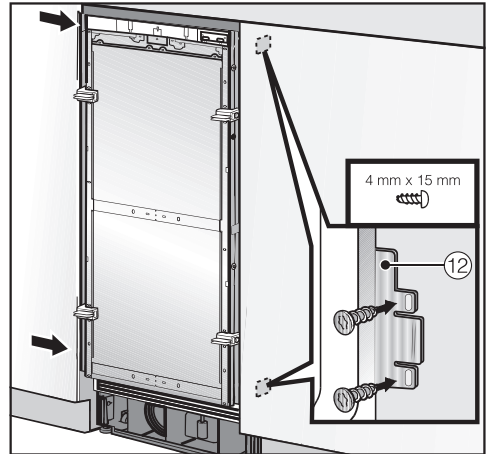

- Screw the lugs of the mounting plate (12) at the top and bottom to the cabinets/units adjacent to the appliance.

In a side-by-side combination, only the external panels of the two appliances can be secured to the adjacent cabinets/units.

Installation

Preparing to install the furniture fronts

- Open the appliance door as far as it will go.

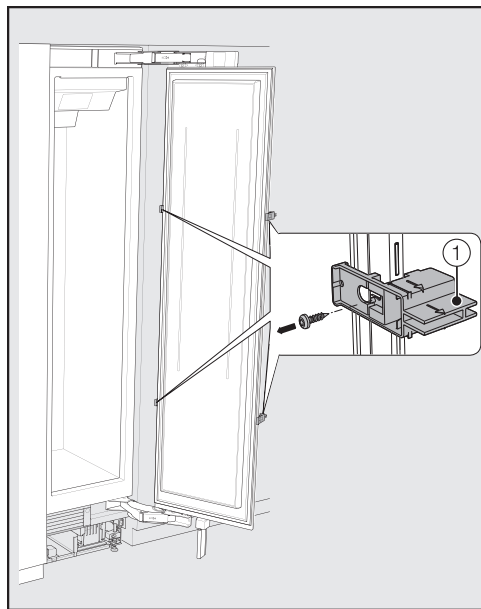

- Unscrew the installation aids ① from the appliance door.

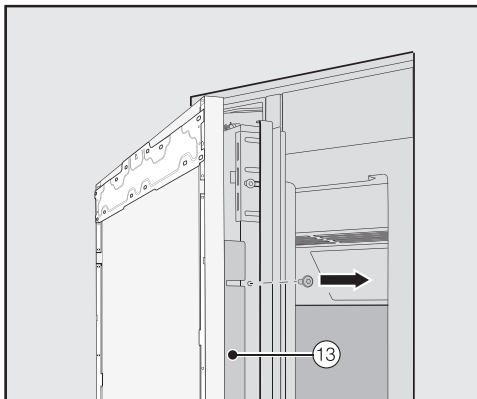

- Unscrew the angle bars ⑬ from both sides of the appliance door and keep the bars and screws in a safe place – they will be required later.
- Close the appliance door.

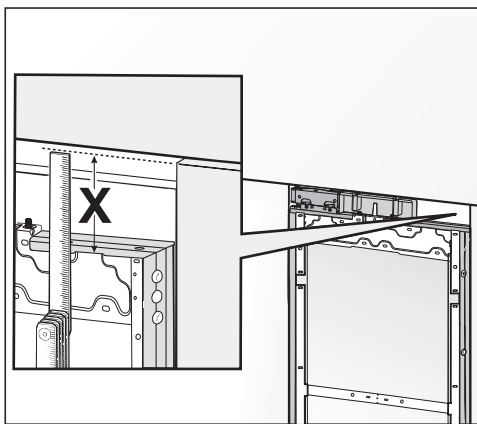

- Measure the gap X between the mounting frame and the upper edge of the adjacent furniture front.

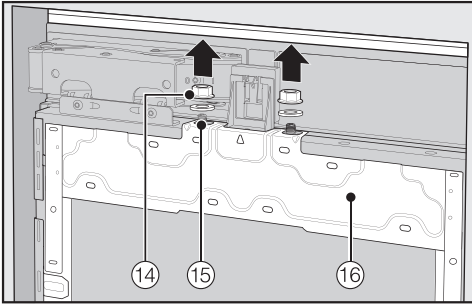

- Remove the nuts and washers (14) from the threaded bolts (15) and store them in a safe place – they will be required later.
- Take the mounting frame (16) off the appliance door by removing it upwards.

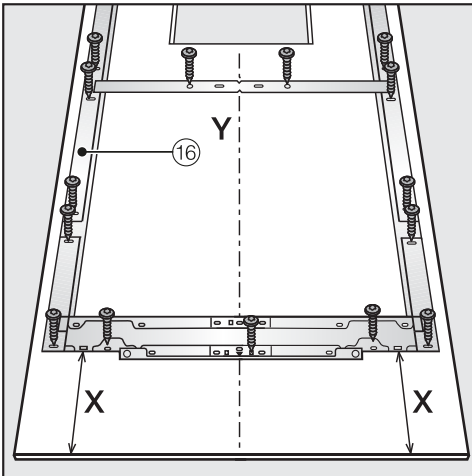

- Place the furniture front on a firm surface with the inside facing upwards (to avoid scratches, place a blanket underneath).
- Mark the distance **X** - 3 mm on the inner side of the furniture front.
- Also locate and mark the centre point **Y** on the furniture front.

- Position the mounting frame (16) according to the markings on the furniture front.
- Pre-drill the holes.



- Screw the mounting frame (16) to the furniture front:
Use at least one screw for each retaining point on the mounting frame (16).

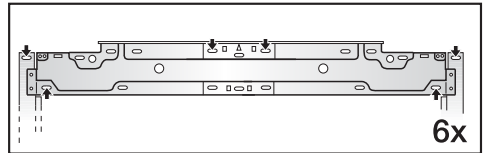

- Secure the mounting frame (16) to the top of the furniture front, using at least 6 screws depending on the size.

The mounting frame has several different types of holes to take account of a variety of furniture fronts. When securing the frame, always screw into the strongest part of the furniture front. To do this, select screws which are slightly shorter than the thickness of the furniture front.

Installation

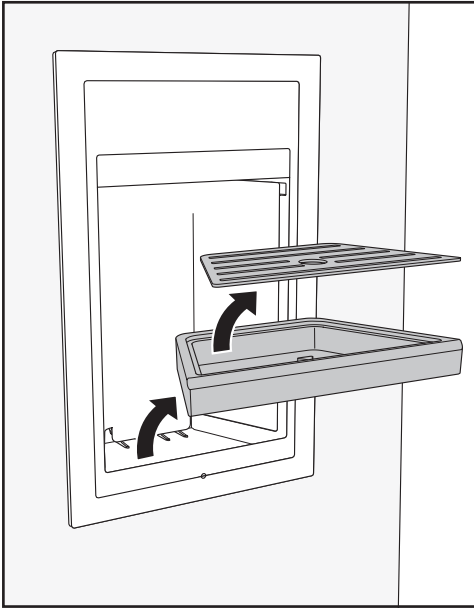

- Remove the drip tray grille and the drip tray from the Ice/Water dispenser.

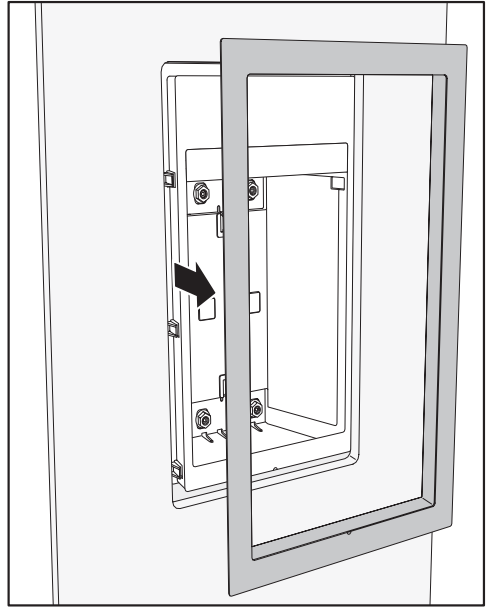

- Remove the frame from the Ice/Water dispenser.
- Screw the appliance handle to the furniture front from the inside if necessary (not for handle-free kitchens).

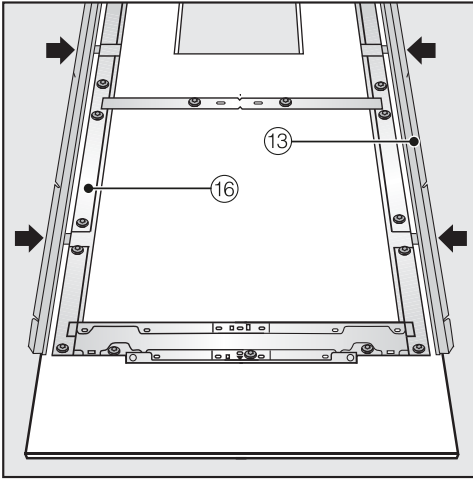

Securing and aligning the furniture front

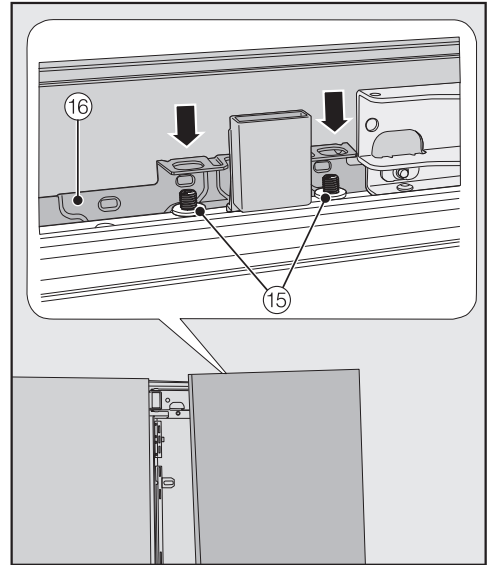

- Now insert the angle bars (13) on both sides as far as they will go into the provided spaces in the mounting frame (16).

- Open the appliance door and hang the furniture front with its mounting frame (16) onto the threaded bolts (15).

Installation

E



- Press the angle bars ⑬ into the white plastic frame on both sides and screw them on loosely at first. Spare screws are provided in the plastic bag marked with the letter E.

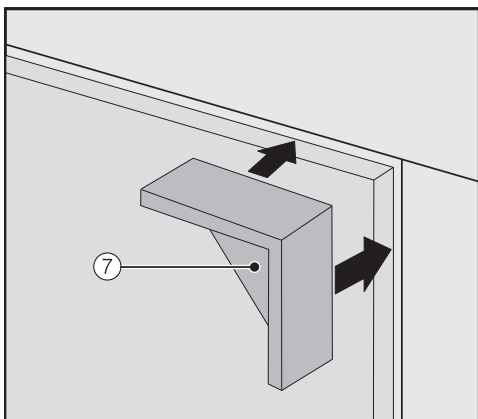

- Place the spacers ⑦ on top of the corners of the furniture front on both sides.
- Close the appliance door and check the distance between the door and adjacent furniture fronts.

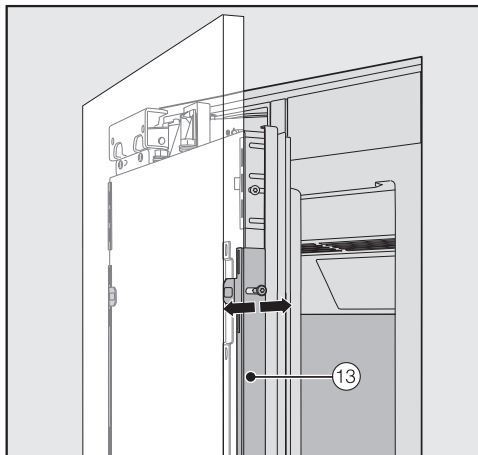

- Align the depth of the furniture front via the slots in the angle bars ⑬.

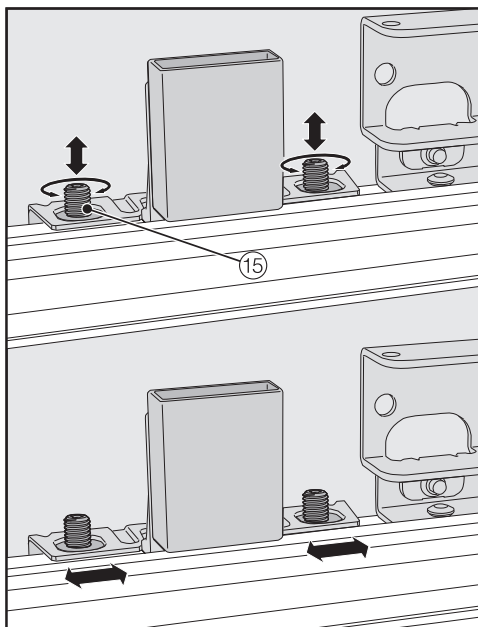

- Align the height and sides of the furniture front with the threaded bolts ⑮ using the TX 20 screwdriver.
- Close the appliance door and check the distance between the door and adjacent furniture fronts again.

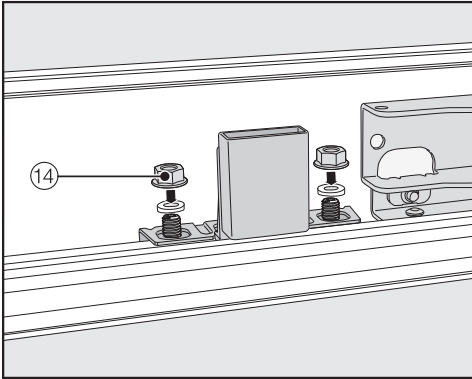

- Place the washers and nuts (14) back in position and tighten the nuts (14).

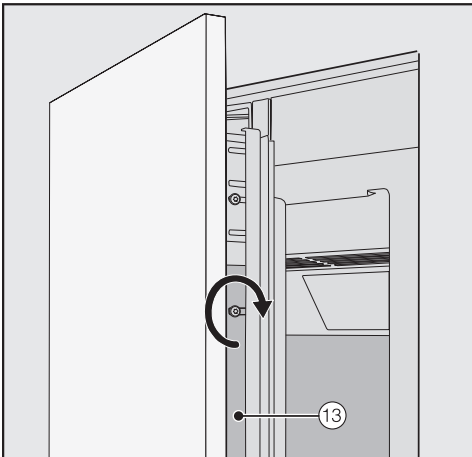

- Tighten the screws in the angle bars (13).

The furniture front is now secured.

- Open the appliance door.
- Remove the spacers (7) from the furniture front.

Fitting the mounting bracket



The mounting bracket is used to secure the furniture front to the bottom of the appliance door.

Do not fit the fixing bracket until the appliance (or side-by-side combination, if applicable) has been installed and the furniture front has been aligned.

- Open the appliance door as far as it will go.

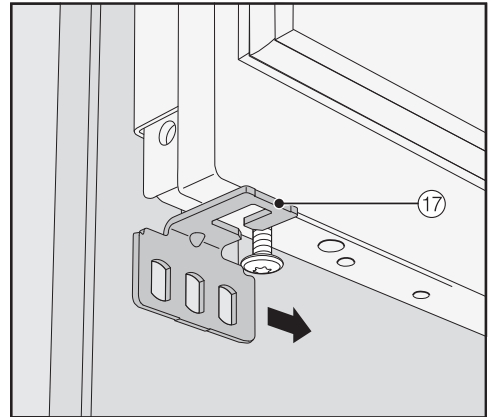

- Slide the fixing bracket (17) sideways onto the screw at the bottom of the appliance door.

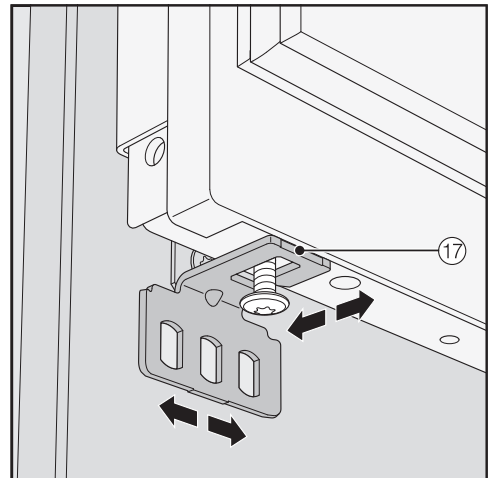

Installation

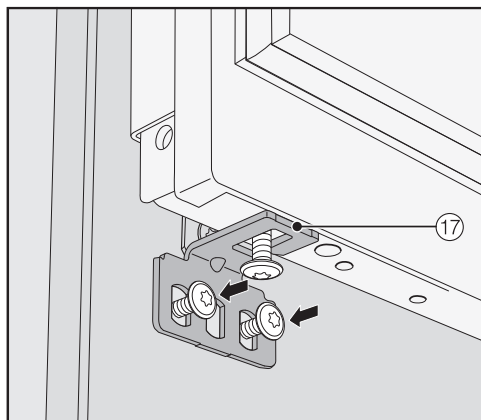

- Screw the fixing bracket 17 securely to the furniture front.

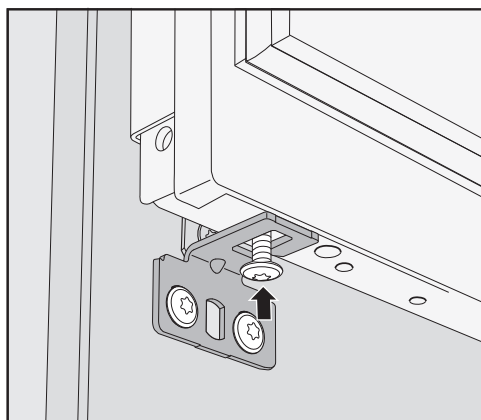

- Tighten the screw at the bottom of the appliance door.

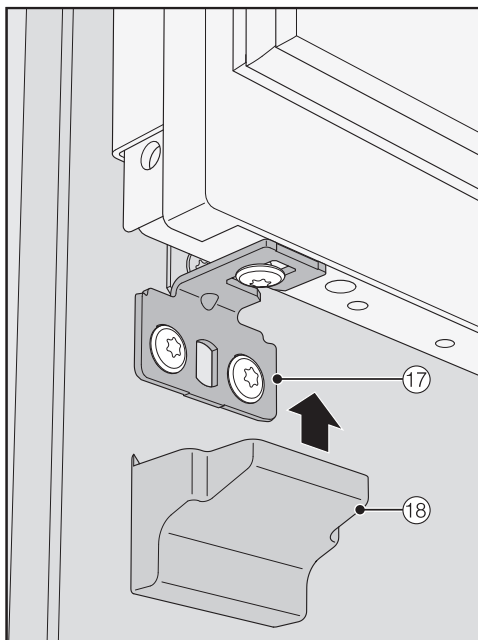

- Place the cover 18 on the fixing bracket 17.

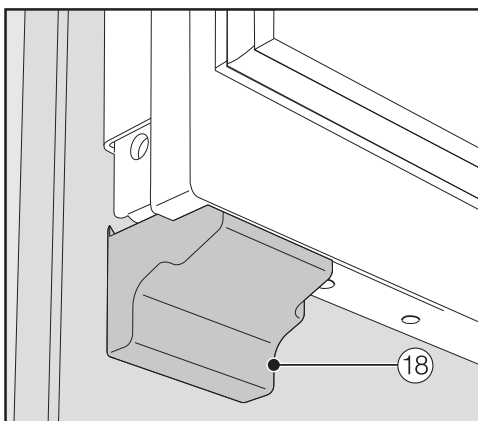

- Snap the cover 18 onto the fixing bracket so that it clicks into place.

Securing the covers

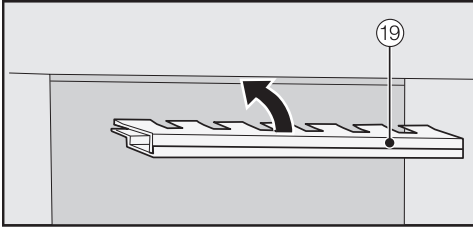

- The top cover ①9 must be assembled as follows before it can be fitted:

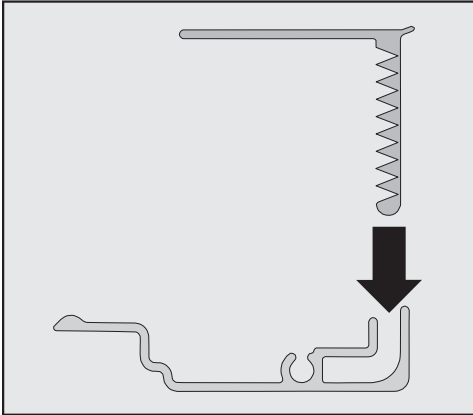

- Insert the two parts of the cover into one another.

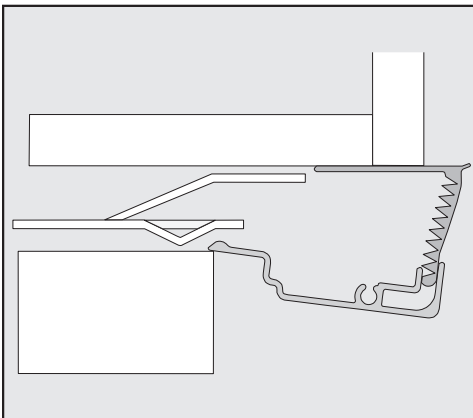

Cover viewed from the side

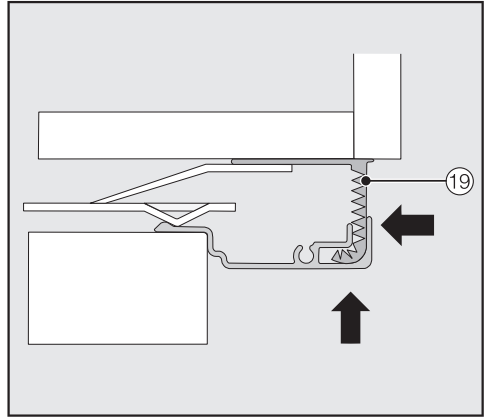

- Place the assembled cover ①9 into the gap above the appliance so that it clicks into place. While doing so, slide both parts of the cover together as required.

Installation

Fitting the cover in a side-by-side combination

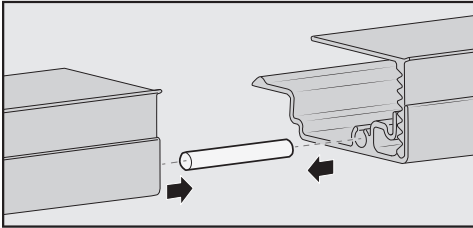

- Insert the joining peg (from the side-by-side installation kit) halfway into the guide in the cover for the left-hand appliance.
- Place the second cover onto the pin and press the two covers together.
- Place the two covers together in the niche above the appliances until they click into place.

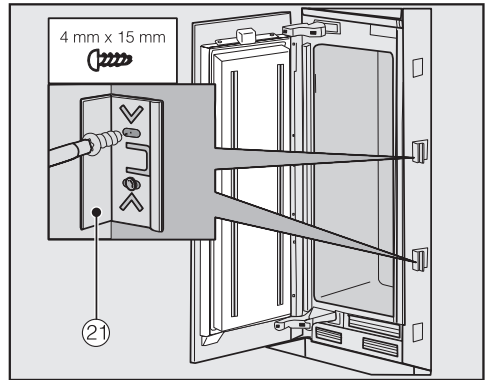

- Secure at least 3 clips (21) on both sides of the appliance for the gap covers.

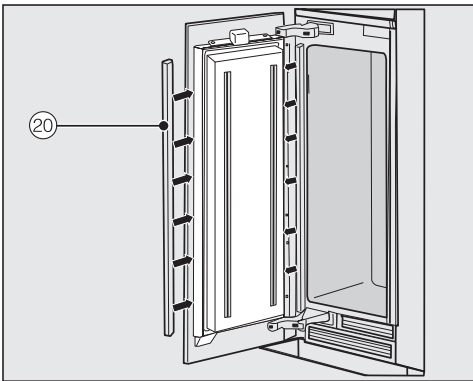

- Fit the plastic covers (20) on both sides of the appliance door by clicking them into the gap between the appliance door and the furniture door, starting at the bottom and working up to the top.

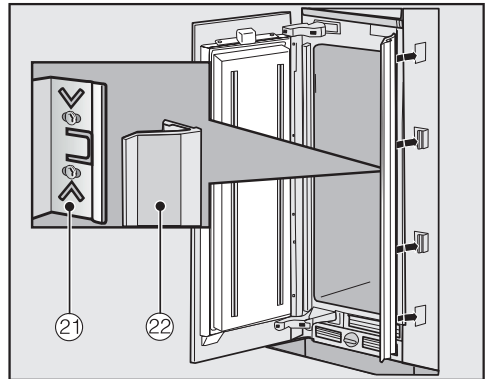

- Then attach the covers (22) onto the clips (21) on both sides. With a side-by-side installation, the covers are only required on the outer sides.

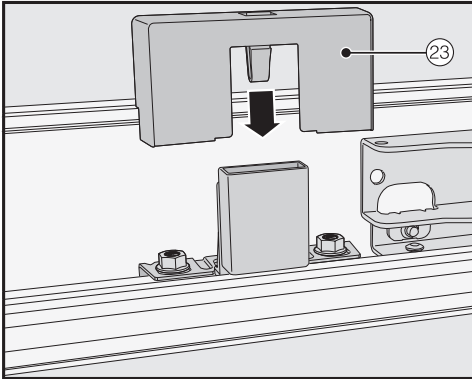

- Install the cover ②③ onto the light contact switch.

Securing the plinth ventilation grille and plinth cover

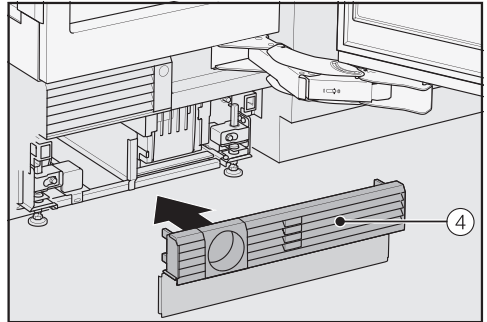

- Click the plinth ventilation grille ④ onto the bottom of the appliance plinth.

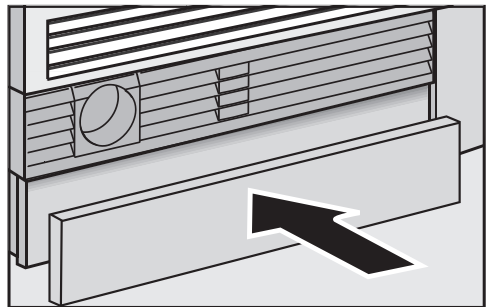

- If necessary, cut the plinth panel to the required length and height (cut along the lower edge of the plinth where it touches the floor).
- Secure the plinth cover to the bottom of the plinth ventilation grille.

Installation

Aligning the Ice/Water dispenser

If necessary, the depth of the Ice/Water dispenser can be aligned to line up with the furniture front.

Switch off at the wall and withdraw the plug from the socket, or switch off the mains circuit breaker.

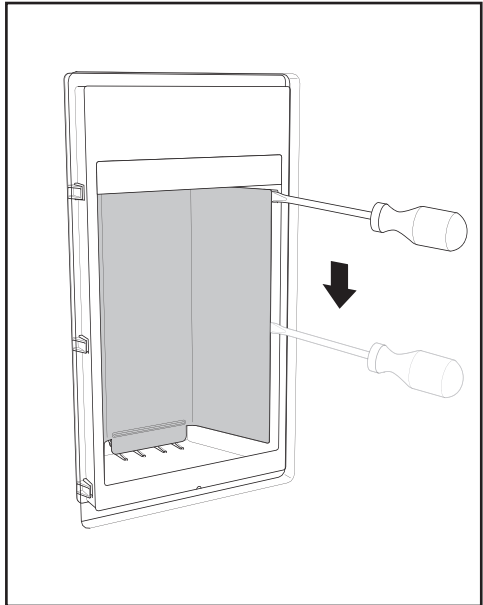

- Carefully insert a screwdriver from the side to remove the rear cover from the dispensing unit.

Proceed with great care to avoid scratching the cover when removing it.

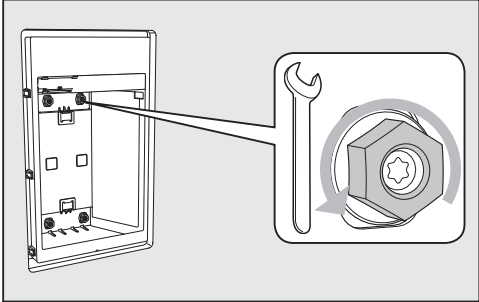

- Use a spanner to loosen the nuts at the back of the the dispensing unit slightly by turning the nuts anti-clockwise.

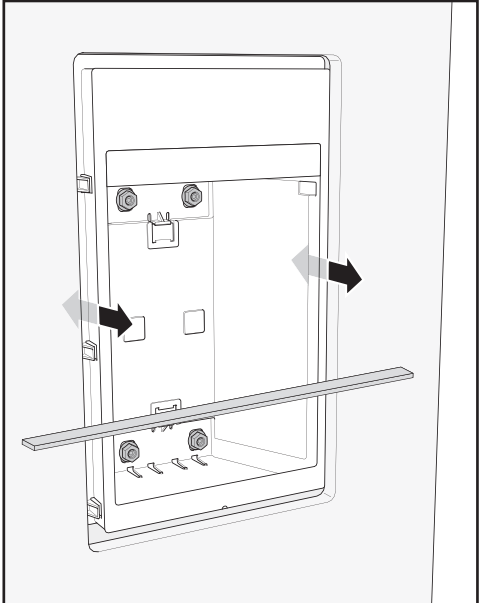

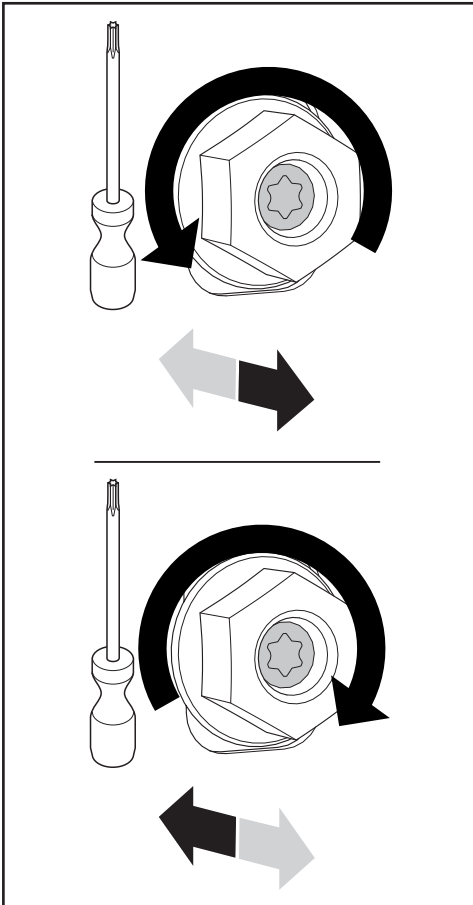

- Then use the 4 screws to line up the depth of the dispensing unit on both sides.

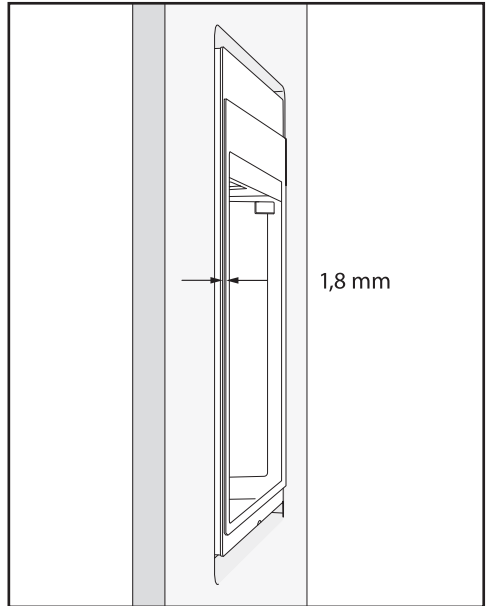

The protrusion from the inner to the outer frame should be 1.8 mm.

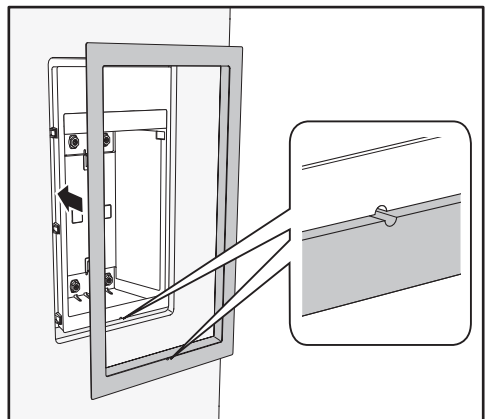

- Align the frame perfectly with the dispensing unit.

Installation

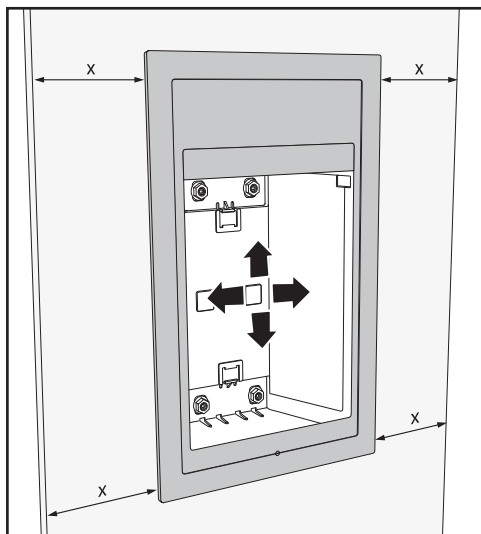

- Align the frame centrally.
- Finally, use a spanner to tighten the nuts by turning them clockwise.

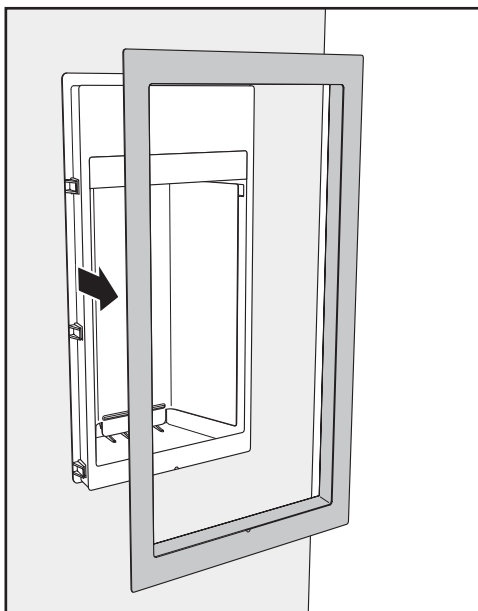

- Remove the frame again.

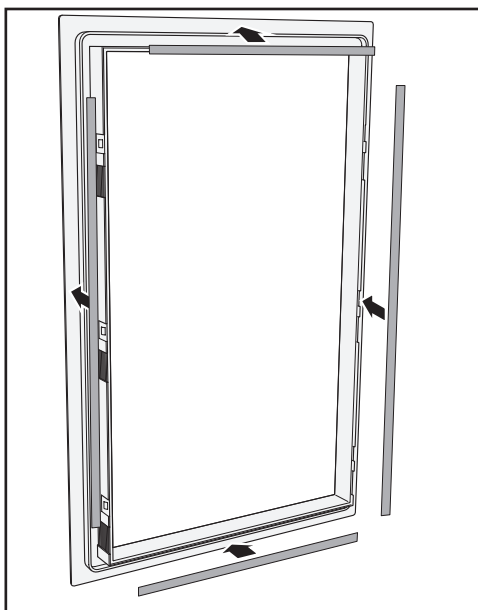

- Attach the adhesive strips provided to the 4 sides of the frame.



- Remove the film from each of the adhesive strips.

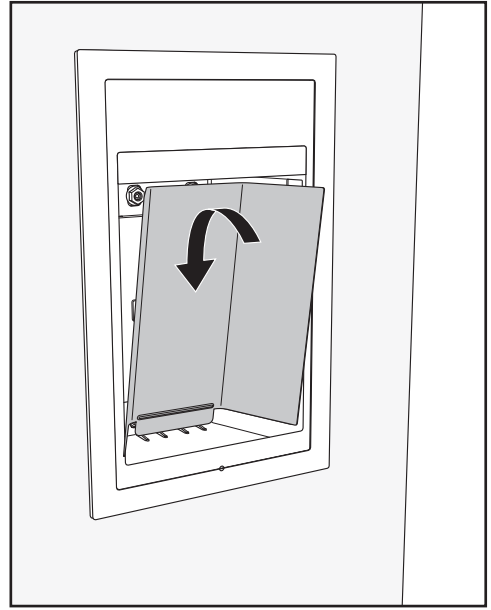

- Refit the rear cover to the dispensing unit, slotting it into place from above.

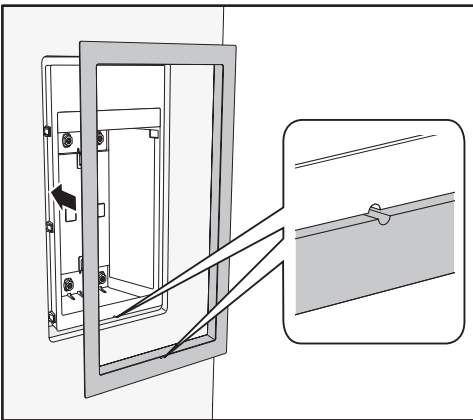

- Align the frame again perfectly with the dispensing unit.

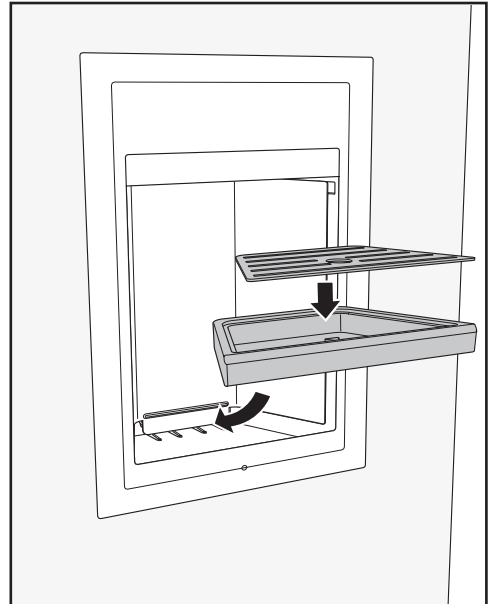

- Insert the drip tray and the drip tray grille.

Installation

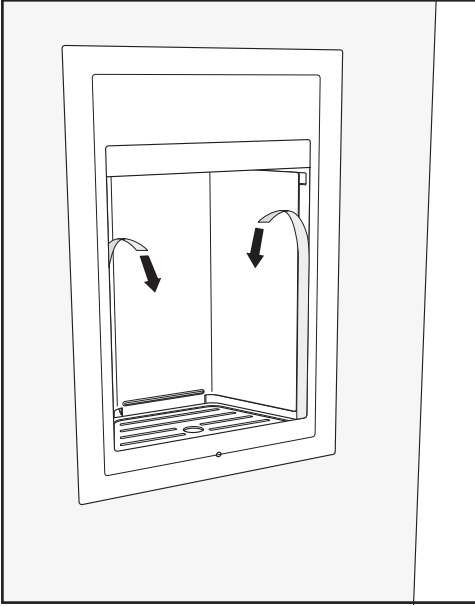

- Then remove the film from both sides of the dispensing unit.

Water connection

Information about the mains water connection

 Risk of injury and damage due to incorrect connection.

Failing to connect the appliance correctly can result in personal injury and/or material damage.

The appliance may only be connected to the water supply by a suitably qualified technician.

 Disconnect the refrigeration appliance from the power supply before connecting it to the water supply.

Turn off the tap before connecting the refrigeration appliance to the mains water.

 Danger to health and property due to contaminated water.

The quality of the water used must conform to the requirements for drinking water in the country where the refrigeration appliance is being used.

Connect the refrigeration appliance to the drinking water supply.

Connection to the water supply must comply with the applicable regulations in the country where the appliance is being installed. All units and systems used to supply water to the refrigeration appliance must also comply with the applicable regulations in the respective country.

The water connection pressure needs to be between 200 kPa and 800 kPa (2 bar and 8 bar).

 Risk of damage due to excessive water connection pressure.

Excessive water connection pressure in the water line can cause damage to the refrigeration appliance.

You must install a pressure reducing valve if the water connection pressure in the water line exceeds 800 kPa (8 bar).

With the pressure reducing valve installed, the maximum water connection pressure at the hose set of the refrigeration appliance cannot exceed 1000 kPa (10 bar).

Contact a plumbing specialist if you are unsure of your water connection pressure.

Use fresh water to ensure that the quality of the ice cubes remains high. Connect the stainless steel hose to the fresh water supply and avoid connection to a water supply in which the water might stagnate.

Only use the stainless steel hose supplied. Old or used hoses must not be connected to the appliance. The stainless steel hose must not be shortened, extended or replaced by another hose.

The stainless steel hose must only be replaced by an original Miele spare part. A stainless steel hose which is suitable for use with drinking water is available to order from Miele (see back cover for contact details).

A tap must be provided between the stainless steel hose and the mains water supply to ensure that the water supply can be shut off if necessary.

Installation

The tap should be easily accessible after the appliance has been built in.

The stainless steel hose is 2 m long and is already installed on the refrigeration appliance when it is delivered.

Connecting the appliance to the mains water supply

By this time, the installation niche should already be prepared so that the appliance only needs to be pushed into it.

When doing so, make sure that the stainless steel hose is not kinked or damaged.

- Position the appliance slightly in front of the niche.

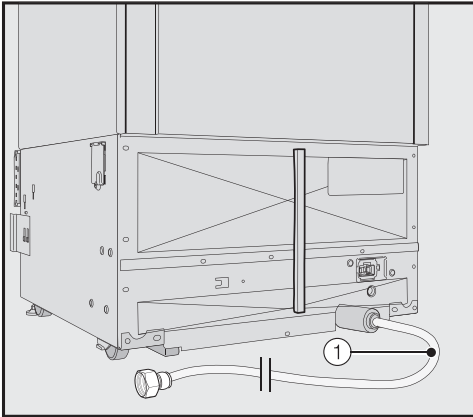

The stainless steel hose ① of the refrigeration appliance is ready for connection.

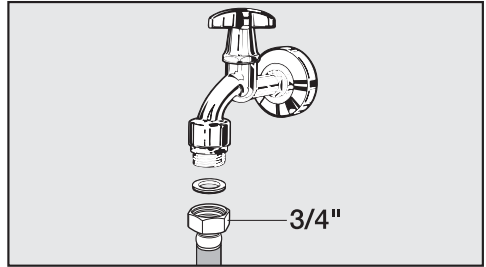

- Connect the stainless steel hose ① to the tap.
- Ensure that it is screwed into position correctly and watertight.
- Turn on the tap slowly and check the whole water system for leaks.
- The appliance can now be installed in the niche (see “Installation - Installing the appliance”).

Electrical connection

The refrigeration appliance must only be connected to an earthed socket using the connection cable supplied.

The socket should be easily accessible after the refrigeration appliance has been installed. If the socket is not easily accessible, ensure that a suitable means of disconnection is provided on the installation side for each pole.

 Risk of fire from overheating.

Connecting the appliance to a multi-socket plug adapter or to an extension lead can overload the cable.

For safety reasons, do not use an extension cable or multi-socket adapter.

All electrical work must be carried out by a suitably qualified and competent person in strict accordance with national and local safety regulations.

For safety reasons, we recommend using a suitable residual current device (RCD) in the relevant electrical installation for connecting the refrigeration appliance.

If the mains connection cable is damaged, it must only be replaced with a specific mains connection cable of the same type (available from Miele).

The data plate indicates the nominal power consumption and the connection data. Compare this information with the data of the on-site electrical connection. If in any doubt, consult a qualified electrician.

Temporary or permanent operation with a self-sufficient or non-mains synchronous energy supply system (e.g. isolated networks, back-up systems) is possible. A requirement for the

operation is that the energy supply system complies with all current local and national requirements that apply to stand-alone, solar and/or battery systems.

The protective measures provided in the domestic installation and in this Miele product must also be assured in their function and operation in isolated operation or in non-mains synchronous operation, or replaced with equivalent measures in the installation.

Connecting the appliance

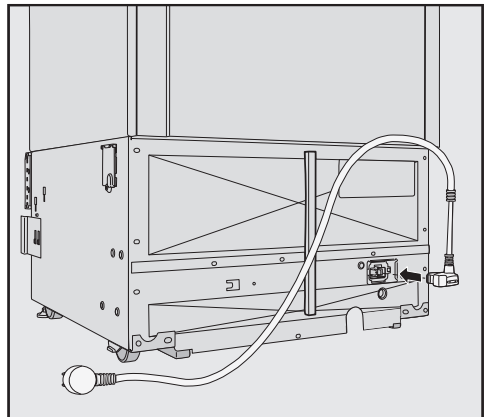

- Insert the plug connector into the back of the appliance.

Make sure that the plug connector has locked into position correctly.

- Insert the plug of the appliance into the socket and switch it on.

The appliance is now connected to the electricity supply.

Saving energy

	Normal energy consumption	Increased energy consumption
Installation/ Maintenance	In a ventilated room.	In an enclosed, unventilated room.
	Protected from direct sunlight.	In direct sunlight.
	Not situated near a heat source (radiator, oven).	Situated near a heat source (radiator, oven).
	Where the ideal ambient room temperature is approx. 20 °C.	Where there is a high room temperature.
	Ventilation gaps kept uncovered and free of dust.	Where the ventilation gaps are covered or dusty.
Temperature settings	Freezer section -18 °C	With a low temperature setting: The lower the temperature in the appliance, the higher the energy consumption.

Saving energy

	Normal energy consumption	Increased energy consumption
Use	Drawers and shelves arranged as they were when the appliance was delivered.	
	Only open the door when necessary and for as short a time as possible. Store food in an organised way.	Frequent opening of the door for long periods will cause a loss of coldness. The appliance will try to cool down and the compressor will run for longer periods.
	Take a cooler bag when shopping and load food in the appliance as quickly as possible on your return home. Allow hot food and drinks to cool down before placing them in the appliance.	Hot food or food at room temperature will raise the temperature inside the appliance. The appliance will try to cool down and the compressor will run for longer periods.
	Store food well packaged.	The evaporation or condensation of liquids in the freezer will cause a loss of coldness.
	Do not overfill the appliance to allow air to circulate.	Poor air circulation will cause a loss of coldness.

Guide to the appliance

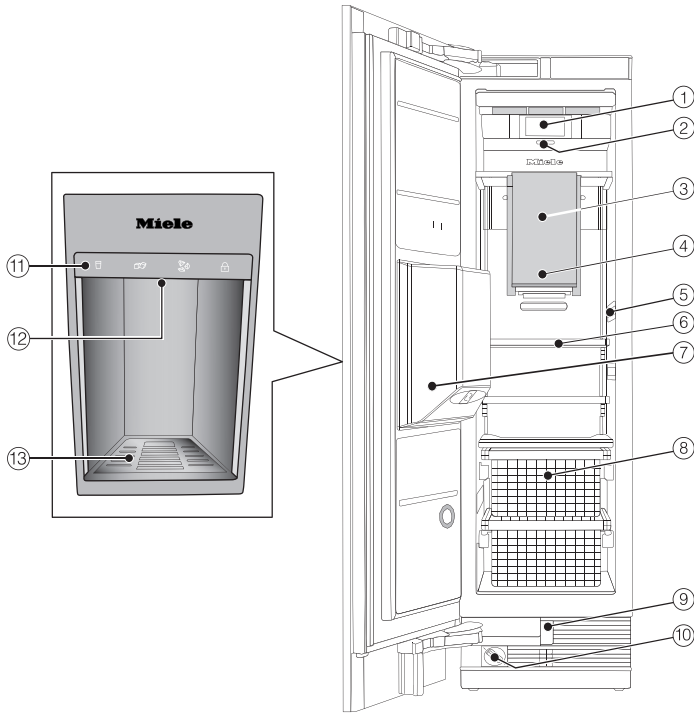

- ① Display
- ② On/Off switch
- ③ Ice cube maker
- ④ Ice cube container
- ⑤ Interior lighting
- ⑥ Shelves
- ⑦ Ice/Water dispenser in the appliance door
- ⑧ Freezer baskets
- ⑨ Automatic door opening (Push2open/Pull2open)
- ⑩ Water filter
- ⑪ Control panel with display
- ⑫ Ice/Water dispenser spout
- ⑬ Drip tray with drip tray grille

Main screen



- ① SuperFreeze display
(only visible when the SuperFreeze function is switched on)
- ② Temperature display (target temperature)
- ③ 🌡️ sensor
for setting the temperature
- ④ Display for Miele@home connection status
(only visible when the Miele@home function has been set up)
- ⑤ Settings mode sensor ⚙️
For adjusting various functions in Settings mode

Guide to the appliance



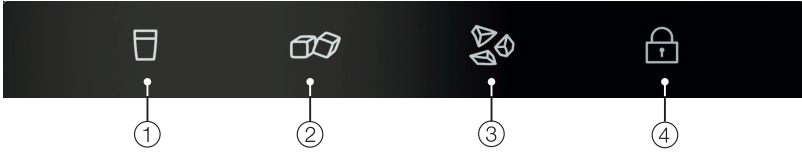





Control panel for Ice/Water dispenser









- ① Sensor control for chilled water
- ② Sensor control for ice cubes
- ③ Sensor control for crushed ice
- ④ System lock activation/deactivation

Settings mode





In Settings mode, you can select the following appliance functions and alter their settings:

Symbol		Function
	Language	Set
	Display brightness	Adjust (darker to brighter)
	Colour scheme	Set (black or white)
	Buzzer tones	Adjust the volume or switch off the Buzzer tones completely (e.g. for the door alarm)
	Keypad tone	Adjust the volume or switch off the Keypad tone completely
°F / °C	Temperature unit	Set (° Fahrenheit or ° Celsius)
	Keypad lock	Switch on or off (see “Selecting further settings”)
	Eco mode	Switch on or off (see “Selecting further settings”)
	Self test	The system restarts and is checked for faults or malfunctions (see “Selecting further settings”)
	Door assistant	(Push2open or Pull2open) Switch on or off (see “Selecting further settings”)

Guide to the appliance

	Miele@home	Set up, deactivate, or query Wi-Fi connection status (see “Selecting further settings”)
	Demo mode	Switch off * (only visible when Demo mode is switched on, see “Selecting further settings”)
	Factory default settings	Reset to factory default settings (see “Selecting further settings”)
	Dispenser unit lighting	Select the lighting settings for the Ice/Water dispenser (see “Selecting further settings”)
	Dispenser unit	Switch the Ice/Water dispenser on or off (see “Operating the Ice/Water dispenser”)
	Sabbath mode	Switch on or off (see “Selecting further settings”)
	Water filter display	Switch on or off or reset (see “Selecting further settings”)

Symbols in Settings mode

	Scroll in Settings mode or select a setting
	Change a setting (e.g. display brightness)
	Confirm a setting
	Exit the menu level

Accessories supplied

Appliance cable and plug

Water filter (IntensiveClear mesh filter)

The IntensiveClear mesh filter, which is already installed in the appliance, filters the mains water for making ice cubes.

The IntensiveClear mesh filter does not need to be replaced, just cleaned (see “Cleaning and care - Cleaning the water filter (IntensiveClear mesh filter)”).

Optional accessories

A range of useful Miele accessories and care products is available for your appliance.

Miele all purpose microfibre cloth

Light soiling and fingerprints on stainless steel fronts, control panels and furniture can be easily removed with this microfibre cloth.

Stainless steel front panel

Stainless steel front panels provide a high-quality exterior design for your refrigeration appliance.

Handles and plinth panels are also available in a stainless steel look.

Side-by-side installation kit

To install two or more refrigeration appliances next to one another, you will need the side-by-side installation kit (see “Installation - Side-by-side units”).

Accessories are available from Miele directly (see back cover for contact details).

Using for the first time

Before using for the first time

Allow the refrigeration appliance to stand for approx. 1 hour before connecting it to the power supply. This will prevent potential functional problems with the appliance.

Removing packaging material

- Remove all packaging material from the inside of the appliance.

Remove all packaging material, including adhesive tape, **before** switching on the appliance. The adhesive tape is difficult to remove from cold surfaces.

Cleaning

Please refer to the relevant instructions in "Cleaning and care".

- Clean the inside of the appliance and the accessories.

Choosing the right Door assistant (Push2open/Pull2open)

The Door assistant helps you to open the appliance door.

You can choose between the two Door assistants Push2open and Pull2open (see "Selecting further settings - Switching on the Door assistant ").

The factory default Door assistant is Push2open.

- Select the Pull2open Door assistant if your refrigeration appliance has a furniture front with a handle.
- Select the Push2open Door assistant if your refrigeration appliance has a handle-free furniture front.

Miele@home

Your refrigeration appliance is equipped with an integrated Wi-Fi module.

Networking is deactivated at the factory.

To use this feature, you will need:

- a Wi-Fi network
- the Miele App
- a Miele user account. You can create a user account via the Miele App.

The Miele App will guide you as you connect your refrigeration appliance to your home Wi-Fi network.

Once the refrigeration appliance is connected to your Wi-Fi network, you can use the App to carry out the following activities, for example:

- Call up information on the operating status of your refrigeration appliance
- Change the settings on your refrigeration appliance

Connecting your refrigeration appliance unit to your Wi-Fi network will increase energy consumption, even when the appliance is switched off.

Make sure that the signal of your Wi-Fi network is sufficiently strong in the area where you want to set up your refrigeration appliance.

Availability of the Wi-Fi connection

The Wi-Fi connection shares a frequency range with other appliances (including microwave ovens and remote control toys). This may result in sporadic or even complete connection failures. Therefore, a constant availability of featured functions cannot be guaranteed.

Miele@home availability

The ability to use the Miele App depends on the availability of the Miele@home service in your country.

The Miele@home service is not available in every country.

For information about availability, please visit www.miele.com.

Miele App

You can download the Miele App from the Apple App Store® or the Google Play Store™ free of charge (only functional in selected countries).



Using for the first time

Operating the refrigeration appliance

The touch display can be scratched by pointed or sharp objects, e.g. pens.

Only touch the display with your fingers.

If your fingers are cold, the touch display may not react.



The sensors underneath the temperature display can be **selected** directly by touch; the symbols and text in or above the temperature display can only be **displayed**.

Settings mode

In Settings mode , you can select different functions of the appliance and alter their settings to some extent (see "Selecting further settings").

- Touch the  sensor to open Settings mode.
- Use the < and > sensors to select the function for which you wish to adjust the settings.
- Confirm your selection with *OK*.
- Adjust the settings using either the < and > sensors or the + and - sensors.
- Confirm your selection with *OK*.

The setting with the **coloured** background is always the **selected** setting; it can be confirmed directly with *OK*.

- Touch the  sensor if you wish to switch to the previous menu level or terminate the process.

Every touch of the display is confirmed by a keypad tone. You can switch off this keypad tone in Settings mode .

Using for the first time

- Open the appliance door.

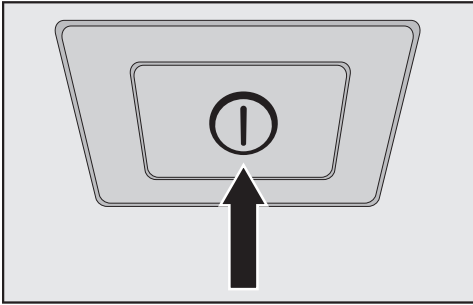



- Switch the refrigeration appliance on by pressing the On/Off switch.

The On/Off switch is located below the display.

The appliance will start to cool and the interior lighting will come on when the door is opened.

Miele will appear in the display.

- When you switch the refrigeration appliance on for the first time, you will be asked to configure the following settings:
 - Set the Language (if you accidentally select the wrong Language, return to Settings mode  and use the  symbol to change the language)
 - Set the Temperature unit: °C (degrees Celsius) or °F (degrees Fahrenheit)
 - Set up Miele@home:
- Select Continue if you would like to set up Miele@home now. You will then be guided by the display and the Miele App.

As soon as your appliance has been integrated into your Wi-Fi network via the App, the message Connection successful will appear in your appliance's display.

- Confirm the process with *OK* again.

If the Wi-Fi connection is active,  will appear in the display.

- Select *Skip* if you would prefer to set up Miele@home later.
- Touch the  sensor if you want to return to the previous menu level.

Set-up successful appears in the display.

- Confirm the initial set-up with *OK*.

The main screen will appear in the display (see "Guide to the appliance - Main screen").

You cannot cancel the initial set-up process. The only way to terminate the process is to switch off the refrigeration appliance, though the process will continue when the appliance is switched back on.

Switching on and off

Switching the appliance on

- Open the appliance door.
- Switch the refrigeration appliance on by pressing the On/Off switch.

The appliance will start to cool and the interior lighting will come on when the door is opened.

Miele will appear in the appliance display, followed by the main screen.

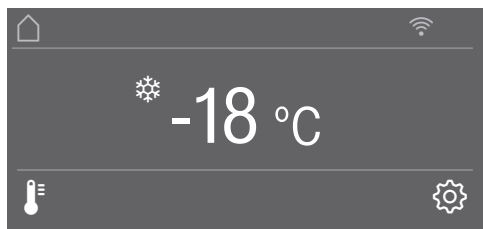

The message Freezer temperature too high. Max. temperature °C will appear in the display when the appliance is switched on for the first time or until the selected temperature has been reached in the freezer.

An alarm sounds.

- Confirm the message with *OK*.

The message will disappear from the display and the alarm will stop.

However, the message may reappear in the display after a short time.

As soon as the selected temperature has been reached in the freezer, the message will disappear completely from the display and the alarm will stop.

To enable the temperature to get sufficiently cold inside the appliance, allow the appliance to run for a few hours before placing food in it. Do not place food in the freezer until the temperature has dropped to at least -18 °C.

 Risk of damage due to high humidity.

In environments with high humidity, condensation can build up on external refrigeration appliance panels. This condensation can cause corrosion and lead to damage on external appliance panels.

Install the refrigeration appliance in a dry and/or air-conditioned room with sufficient ventilation.

Do not switch the refrigeration appliance on if you are going to be away for a long period of time.

Do not leave the refrigeration appliance unattended for a long period of time while it is switched on.

Switching off the appliance

- Switch the appliance off by pressing the On/Off switch.

The cooling and interior lighting are switched off.

Please note: The refrigeration appliance is not disconnected from the power supply when it is switched off with the On/Off switch.

Switching off for longer periods of time

If the appliance is not going to be used for a longer period of time, e.g. whilst on holiday:

- Switch the appliance off.
- Switch off at the wall and withdraw the plug from the socket, or switch off the mains circuit breaker.

 Risk of damage due to frozen water intake pipe.

If the water supply is turned off while the ice cube maker is still in operation, the water intake pipe may freeze.

Switch the Ice/Water dispenser off if the water supply is to be interrupted (e.g. during holidays).

- Turn off the tap for the water supply (approx. 3 hours before switching off the appliance to avoid the build-up of mould caused by stagnant water).
- Empty the ice cube container.
- Clean the appliance.
- Clean the water filter.
- Leave the door ajar to air the appliance and to prevent odours building up.

If, during a long absence, the appliance is switched off but not cleaned and the door(s) left shut, there is a risk of mould forming inside the appliance.

It is essential to clean the appliance.

Selecting further settings

In Settings mode , you can select different functions of the refrigeration appliance and alter their settings, allowing you to adjust the appliance to suit your requirements.

Only the functions in Settings mode  that require further explanation are described below.

The door alarm and other warnings are automatically disabled when the appliance is in Settings mode .

Switching the Keypad lock / on or off

Switching on the Keypad lock prevents an inadvertent temperature adjustment or unwanted changes while in Settings mode .

- In Settings mode , use the < and > sensors to select Keypad lock and touch *OK* to confirm your selection.
- Use the < and > sensors to switch the sensor lock On or Off and select *OK* to confirm your selection.
- The sensor lock will not be activated until you close the appliance door.

Nothing will appear in the display to indicate that the sensor lock is switched on.

The message *Press OK for 6 seconds to unlock* will appear in the display if you select a sensor while the sensor lock is switched on.

- Follow the instructions in the display.

The display is unlocked briefly so you can adjust settings as required. Closing the appliance door will reactivate the sensor lock.

Switching Eco mode on or off

Eco mode is useful when going on a holiday, for example, if you do not wish to switch off the appliance completely or do not need a high degree of cooling. Energy consumption in Eco mode is lower than in normal operation.

The freezer is regulated to a temperature of $-16\text{ }^{\circ}\text{C}$.

If the SuperFreeze function  is switched on, it will be switched off when Eco mode is selected.

- In Settings mode , use the < and > sensors to select Eco mode and touch *OK* to confirm your selection.
- Use the < and > sensors to switch Eco mode On or Off and confirm your selection with *OK*.



Only the changed temperature in the display indicates that Eco mode is switched on.

Useful tip: You can also switch off the Eco mode function by directly adjusting the temperature  (see "The correct temperature - Setting the temperature").

 Health risk due to consumption of spoiled food.
The shelf life and quality of food may be affected if the temperature remains above $-18\text{ }^{\circ}\text{C}$ for an extended period.
Only ever switch on the Eco mode function for a limited period.
When switching to Eco mode, ensure that the food in the freezer is already properly frozen.
Do not freeze any new food while the Eco mode function is switched on.

Carrying out a Self test

Perform a Self test if you feel that your refrigeration appliance is not functioning properly and needs to be checked for any malfunctions.

- In Settings mode , use the < and > sensors to select Self test and touch *OK* to confirm your selection.
- Touch the  sensor if you wish to terminate the process.

The Self test starts and the appliance is checked for any faults or malfunctions.

- If the Self test does not detect any faults or malfunctions, the display will show the message *System restart*.
- If the Self test does discover any faults or malfunctions, they are indicated as error messages in the display.

An alarm tone also sounds.

- If you find the alarm disruptive, you can switch it off early by touching the  sensor.
- Make a note of the error message(s) displayed.
- Contact customer service and inform them of the error message(s) in the display.
- Confirm the message with *OK*.

System restart will appear in the display.

The appliance will briefly switch off and then back on automatically.

Self test completed will appear in the display.

- Confirm the message with *OK*.

The main screen will appear in the display.

Switching on the Door assistant

You can choose between the two Door assistants *Push2open* and *Pull2open*. The factory default Door assistant is *Push2open*.

The *Push2open* Door assistant is suitable for furniture fronts without handles. The door will open automatically when you gently press against it.

The *Pull2open* Door assistant is suitable for furniture fronts with handles. The appliance door can be opened easily and with little effort.

 Risk of damage if the appliance door is closed prematurely. When the Door assistant is switched on, repeatedly closing the appliance door early can lead to damage or malfunctions. Refrain from holding onto or closing the appliance door while the automatic door opening is still extended. If you have closed the appliance door despite this, leave it closed for 5 minutes. The automatic door opening will reset itself.

Selecting further settings

Switching on Push2open

- In Settings mode , use the < and > sensors to select Door assistant and touch *OK* to confirm your selection.
- Use the < and > sensors to select Mode and confirm your selection with *OK*.
- Use the < and > sensors to select Push2open and confirm your selection with *OK*.
- Touch the ↶ sensor to return to the previous menu level.

– Adjusting the intensity

You can also adjust the intensity of the Push2open function. The lower the intensity, the less force is required when you push against the appliance door.

- In Settings mode , use the < and > sensors to select Door assistant and touch *OK* to confirm your selection.
- Use the < and > sensors to select Intensity and touch *OK* to confirm your selection.
- Use the < and > sensors to select the desired intensity (Low, Medium, High) and select *OK* to confirm your selection.

- Adjusting the duration of the AutoClose function

You can also adjust the duration for how long the appliance door will remain open until it closes automatically.

- In Settings mode , use the < and > sensors to select Door assistant and touch *OK* to confirm your selection.
- Use the < and > sensors to select AutoClose and touch *OK* to confirm your selection.
- Use the + and – sensors to select the duration (5 to 30 seconds) and confirm your selection with *OK*.

To protect against unintentional opening: If you do not pull the appliance door open, it will close again by itself after the duration defined by you.

Switching on Pull2open

- In Settings mode , use the < and > sensors to select Door assistant and touch *OK* to confirm your selection.
- Use the < and > sensors to select Mode and confirm your selection with *OK*.
- Use the < and > sensors to select Pull2open and confirm your selection with *OK*.
- Touch the ↶ sensor to return to the previous menu level.

– Adjusting the intensity



You can also adjust the intensity of the Pull2open function. The lower the intensity, the less force is required when you pull the appliance door open.

- In Settings mode , use the < and > sensors to select Door assistant and touch *OK* to confirm your selection.

Selecting further settings

- Use the < and > sensors to select Intensity and touch *OK* to confirm your selection.
- Use the < and > sensors to select the desired intensity (Low, Medium, High) and touch *OK* to confirm your selection.

Switching off the Door assistant

- In Settings mode , use the < and > sensors to select Door assistant and confirm your selection with *OK*.
- Use the < and > sensors to select Mode and confirm your selection with *OK*.
- Use the < and > sensors to select Off and confirm your selection with *OK*.
- Touch the  sensor to return to the previous menu level.

Selecting further settings

Miele@home

Setting up Miele@home

The message *Set up Miele@home* only appears if the refrigeration appliance has not yet been connected to a Wi-Fi network.

- Connect your refrigeration appliance as described in “Using for the first time”.

Deactivating Miele@home

- In Settings mode , use the < and > sensors to select Miele@home and touch *OK* to confirm your selection.
- Use the < and > sensors to select *Deactivate* and confirm your selection with *OK*.

Deactivation successful will appear in the display.

- Confirm the message with *OK*.

Your refrigeration appliance is now disconnected from your Wi-Fi network. The  symbol will go out in the display.

Activating Miele@home

If you have previously activated Miele@home and then deactivated the connection, you can reactivate the connection.

- In Settings mode , use the < and > sensors to select Miele@home and touch *OK* to confirm your selection.
- Use the < and > sensors to select *Activate* and confirm your selection with *OK*.

Activation successful will appear in the display.





- Confirm the message with *OK*.

If the Wi-Fi connection is active,  will appear in the display.

Checking the Wi-Fi connection status

- In Settings mode , use the < and > sensors to select Miele@home and touch *OK* to confirm your selection.
- Use the < and > sensors to select *Connection status* and confirm your selection with *OK*.

Information about the Wi-Fi connection status will appear in the display:

-  connected: strong connection
-  connected: average connection
-  connected: weak connection
- : no connection

Selecting further settings

Setting up Miele@home again

If you have changed your Wi-Fi network, you can set up Miele@home again for your appliance.

- In Settings mode , use the < and > sensors to select Miele@home and touch *OK* to confirm your selection.
- Use the < and > sensors to select Set up again and confirm your selection with *OK*.

Reset configuration? will appear in the display.

- Use the < and > sensors to select Yes or No and confirm your selection with *OK*.

Resetting the network configuration

Reset the appliance's settings to the factory settings when disposing of your refrigeration appliance, selling it or putting a used refrigeration appliance into operation. This will reset the network configuration so that all personal data is deleted from the refrigeration appliance. This will also ensure that, in the case of the latter, a previous owner is no longer able to access the appliance.

- Reset the settings of the refrigeration appliance as described in the chapter "Resetting the settings to their factory default settings ".

Switching off Demo mode

Demo mode allows the appliance to be presented in a showroom **without the cooling system being switched on**. Do not activate this setting for domestic use.

If Demo mode has been switched on at the factory,  will show in the display.

- In Settings mode , use the < and > sensors to select Demo mode and touch *OK* to confirm your selection.

Press *OK* for 4 seconds to deactivate will appear in the display.

- Follow the instructions in the display.

The countdown Demo mode will deactivate in seconds will appear in the display.

Demo mode deactivated. Appliance cooling switched on will appear in the display.

- Confirm the message with *OK*.

The main screen will appear in the display.

Selecting further settings

Resetting the settings to their factory default settings

You can reset the appliance's settings to their default settings.

Reset the appliance's settings to the factory settings when disposing of your refrigeration appliance, selling it or putting a used refrigeration appliance into operation. This will reset the network configuration so that all personal data is deleted from the refrigeration appliance. This will also ensure that, in the case of the latter, a previous owner is no longer able to access the appliance.

- In Settings mode , use the < and > sensors to select Factory default settings and touch *OK* to confirm your selection.
- Use the < and > sensors to select Reset and confirm your selection with *OK*.













After a short while, Settings reset will appear in the display.

- Confirm the message with *OK*.

The initial setup process restarts (see “Using for the first time - Before using for the first time”).

The refrigeration appliance's settings will be reset to the following values:

Selecting further settings

Function	Factory default setting	
	Language	English
	Display brightness	middle value (4 of 7 segments)
	Colour scheme	black
	Buzzer tones	middle value (4 of 7 segments)
	Keypad tone	middle value (4 of 7 segments)
°C/°F	Temperature unit	° Celsius
	Keypad lock	switched off
	Eco mode	switched off
	Door assistant	Push2open
@	Miele@home	switched off
	Dispenser unit lighting	Automatic
	Dispenser unit	switched on
	Sabbath mode	switched off
	Water filter display	switched on
	Temperature	-18 °C



Selecting further settings

Selecting settings for lighting the Ice/Water dispenser

In Settings mode , you can select settings for the lighting of the Ice/Water dispenser.



Lighting for Ice/Water dispenser switches on automatically

The lighting is automatically switched on when a container is placed under the Ice/Water dispenser.

- In Settings mode , use the < and > sensors to select Dispenser lighting and touch *OK* to confirm your selection.
- Use the < and > sensors to select Mode and confirm your selection with *OK*.
- Use the < and > sensors to select Automatic and confirm your selection with *OK*.
- Touch the  sensor to return to the main screen.



Lighting for Ice/Water dispenser switches on manually

The lighting is switched on by pressing any sensor on the control panel of the Ice/Water dispenser.

- In Settings mode , use the < and > sensors to select Dispenser lighting and touch *OK* to confirm your selection.
- Use the < and > sensors to select Mode and confirm your selection with *OK*.
- Use the < and > sensors to select Manual and confirm your selection with *OK*.
- Touch the  sensor to return to the main screen.

Lighting for Ice/Water dispenser switches off after a certain time



The Ice/Water dispenser lighting switches off after a set time (0–30 seconds).

- In Settings mode , use the < and > sensors to select Dispenser lighting and touch *OK* to confirm your selection.
- Use the < and > sensors to select AutoOff and confirm your selection with *OK*.
- Use the + and – sensors to set the time you want. Keeping your finger on the sensor changes the time continuously.
- Confirm your selection with *OK*.
- Touch the  sensor to return to the main screen.

Switching off the Ice/Water dispenser lighting

The Ice/Water dispenser lighting is switched off completely.

Selecting further settings

- In Settings mode , use the < and > sensors to select Dispenser lighting and touch *OK* to confirm your selection.
- Use the < and > sensors to select Mode and confirm your selection with *OK*.
- Use the < and > sensors to select Off and confirm your selection with *OK*.
- Touch the  sensor to return to the main screen.

Switching Sabbath mode on or off

The refrigeration appliance has a Sabbath mode to support the observance of religious customs.

When Sabbath mode is switched on, you cannot configure any settings on your refrigeration appliance.

Ensure that the appliance door is properly closed, as visual and audible alarms are switched off in Sabbath mode.

- In Settings mode , use the < and > sensors to select Sabbath mode and touch *OK* to confirm your selection.
- Use the < and > sensors to select On or Off and confirm your selection with *OK*.

When Sabbath mode is switched on,  will appear in the display and the display brightness will be reduced (the display does not change when the appliance door is closed).

When Sabbath mode  is switched on, the following functions are switched off:

- the Door assistant
(with furniture fronts without handles, the appliance door will have to be pulled from the bottom or side)
- the lighting
- all acoustic and visual signals
- the temperature display
- the SuperFreeze function
(if previously switched on)
- the ice cube maker
(if previously switched on)
- The Ice/Water dispenser
(if previously switched on)

Selecting further settings

You can still select:

- the sensor for Settings mode  so that Sabbath mode can be switched off.

The Sabbath mode function will switch itself off automatically after approx. 125 hours.

 Health risk due to consumption of spoiled food.

As a power cut during Sabbath mode is not indicated, frozen goods may thaw or defrost. This shortens the shelf life of the food.

Check the quality of the food.

Check whether the frozen food has started to defrost. If it has, check that the food is safe to use and if it is, use it as soon as possible or cook it before freezing it again.

Switching on, switching off, or resetting the Water filter display

Depending on the quantity of ice cubes produced, the Water filter display will remind you approx. every 6 months that the water filter needs to be cleaned. Clean the water filter will appear in the display.

See “Cleaning and care - Cleaning the water filter (IntensiveClear mesh filter)” for information on how to clean the IntensiveClear water filter.

The first time the water filter needs to be cleaned, the display will remind you automatically; the reminder does not need to be switched on separately.

Switching on the Water filter display



If the Water filter display has been switched off, it must be switched on again if required.

- In Settings mode , use the < and > sensors to select Water filter display and select *OK* to confirm your selection.
- Use the < and > sensors to select On and confirm your selection with *OK*.

The Water filter display has been switched on.

Switching off the Water filter display



- In Settings mode , use the < and > sensors to select Water filter display and select *OK* to confirm your selection.
- Use the < and > sensors to select Off and confirm your selection with *OK*.

The Water filter display has been switched off.

Resetting the Water filter display



After you have cleaned the water filter, you must reset the Water filter display so that it will be displayed automatically again after approx. 6 months.

If you do not reset the reminder, it will appear again and again.

- In Settings mode , use the < and > sensors to select Water filter display and select *OK* to confirm your selection.
- Use the < and > sensors to select Reset and confirm your selection with *OK*.

The Clean the water filter message disappears from the display.

The Water filter display has been activated for the next time the water filter requires cleaning.

The correct temperature

It is very important to set the correct temperature to ensure the shelf life of food. Reducing the temperature reduces the growth rate of microorganisms. Food does not spoil as quickly.

To freeze fresh food, a temperature of **-18 °C** is required. This will prolong the storage life of your food and retain its quality.

As soon as the temperature rises above -10 °C, the bacteria become active in the food again so it cannot be kept as long. For this reason, partially defrosted or defrosted food must not be refrozen. Food may be refrozen once it has been cooked, as the high temperatures achieved during cooking destroy most bacteria.

The temperature in the appliance will rise:

- the more often the door is opened and the longer it is kept open.
- the more food is stored in it.
- the warmer the food is which is being put into it.
- the higher the ambient temperature surrounding the refrigeration appliance. This refrigeration appliance is designed for use within specific ambient temperatures (climate range). Do not use it in ambient temperatures for which it is not designed.

Setting the temperature

- Touch the  sensor for setting the temperature.

The previously set temperature will appear.

- Use the + and – sensors to set the temperature. Keeping your finger on the sensor changes the temperature continuously.
- Confirm the temperature setting with *OK* or wait approx. 8 seconds after the last touch of a sensor. The temperature will then be adopted automatically.

Useful tip: The newly set temperature can also be confirmed and adopted by closing the appliance door.

The temperature display always shows the **required** temperature.

If you have adjusted the temperature, **wait for approx. 6 hours if the appliance is not very full and for approx. 24 hours if the appliance is full** before checking the temperature. It will take this long for the required temperature to be reached.

- If, after this time, the temperature is still too high or too low, adjust it again.

Temperature range

The temperature can be set from -14 °C to -24 °C.

The ambient temperature in the room and the installation location can affect the time it takes for the appliance to reach the lowest temperature.

If the ambient temperature is too high, the appliance may not reach the lowest temperature.

Using SuperFreeze

SuperFreeze function ❄️

For best results, switch on the SuperFreeze function before putting fresh food into the freezer.

This helps food to freeze quickly and retain its nutrients, vitamins, flavours and appearance.

Exceptions:

- When placing food in the freezer that is already frozen.
- If you only freeze up to 2 kg fresh food daily.

Switching on SuperFreeze

SuperFreeze should be switched on **4–6 hours before you place food in the freezer**. When freezing the **maximum amount of food** the SuperFreeze function should be switched on **24 hours beforehand**.

- Touch the  sensor for setting the temperature.
- Touch the ❄️ sensor to switch the SuperFreeze function on.

The ❄️ symbol will be highlighted in colour and the newly set temperature value of -30 °C will appear in the display.

- Confirm the setting with *OK* or wait approx. 8 seconds after the last touch of the sensor. The setting will then be automatically adopted.

The symbol ❄️ will light up in the temperature display.

The appliance will run at maximum power.

Switching off SuperFreeze

- Touch the  sensor for setting the temperature.

The ❄️ symbol will be highlighted in colour and the temperature value of -30 °C is shown in the display.

- Touch the ❄️ sensor to switch the SuperFreeze function off.

The ❄️ symbol is no longer highlighted in colour and the previous temperature setting appears again in the display.

- Confirm the setting with *OK* or wait approx. 8 seconds after the last touch of the sensor. The setting will then be automatically adopted.

The ❄️ symbol disappears from the temperature display.

The refrigeration appliance will run at normal power again.

If you do not switch off the SuperFreeze function, it will turn itself off automatically after approx. 54 hours. The quantity of fresh food placed in the freezer will determine the time before SuperFreeze switches off. The appliance will then run at normal power again.

Useful tip: To save energy, you should manually switch the SuperFreeze function off once the freezer reaches a **constant** temperature of -18 °C or colder. Check the temperature in the freezer.

The appliance has been fitted with a warning system which ensures that the temperature in the freezer cannot rise unnoticed and to avoid energy being wasted if the door is left open.

Temperature alarm

The Freezer temperature too high. Max. temperature °C message appears in the display if the temperature in the freezer zone becomes too warm.

An alarm also sounds.

The temperature display shows the highest value that occurred during the temperature rise.

The acoustic and visual signals are triggered, for example:

- when the refrigeration appliance is switched on and the temperature in the appliance differs greatly from the set temperature
- if a lot of room air enters the freezer as food is being loaded, rearranged or taken out
- when freezing large amounts of food at once
- when you freeze fresh food that is still warm
- after a power cut.

The alarm will stop and the message in the display will go out as soon as the reason for the alarm has been resolved.

 Health risk due to consumption of spoiled food.

If the temperature in the freezer remains above -18 °C for a long time, the frozen goods may start to defrost. This shortens the shelf life of the food.

Check whether the frozen food has started to defrost. If it has, check that the food is safe to use and if it is, use it as soon as possible or cook it before freezing it again.

Switching the temperature alarm off early

Before you switch the temperature alarm off, you must determine the cause and rectify it.

You can switch the alarm off early if you wish.

- Touch the *OK* sensor.

The alarm will stop and the message will disappear from the display.

Temperature and door alarm

Door alarm

An alarm will sound if the appliance door has been left open for longer than 2 minutes.

In addition, the *Close the door* message will appear in the display.

As soon as the door is closed, the alarm will stop and the message in the display will disappear.

Switching the door alarm off early

You can switch the alarm off early if you wish.

- Touch the *OK* sensor.

The alarm will stop and the message will disappear from the display.

The alarm will sound again and the message will reappear in the display after a while if the appliance door has not been closed.

Adjusting the interior fittings

Moving or removing the adjustable shelves

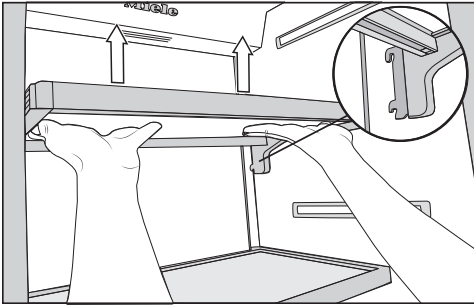

- Hold the shelf on both sides and raise it slightly so that it can be lifted with the catches over the guide at the back.
- Pull the shelf forwards.
- Remove the shelf or refit it in the required position in the guide with the catches.
- Make sure that the shelf is straight.

Removing the shelf above the ice cube maker

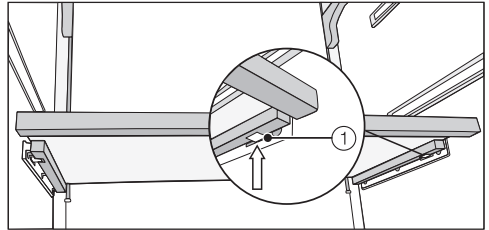

- Use both hands to grip the front of the shelf from below and press it on both sides until you feel resistance ①.

When pulling out and inserting the shelf, make sure that the side walls are not damaged.

- Carefully pull the shelf out to the front.
- To insert it, slide the shelf slowly onto the guide on both sides and then slide it all the way in.

Adjusting the interior fittings

Removing the freezer baskets

- Open the appliance door as wide as possible.

The opening angle of the appliance door must not be limited to 90° because otherwise the freezer baskets cannot be removed.

- Pull the freezer basket out as far as it will go.

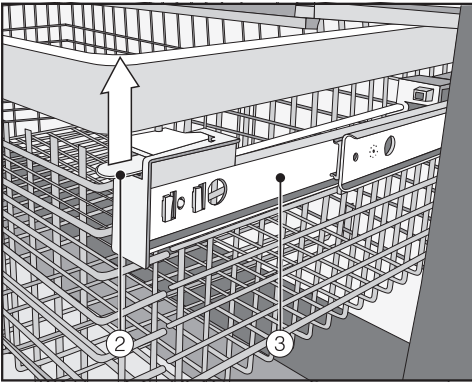

- Raise the snap fastening ② on both sides, unclip, and carefully lift the basket out.
- To refit it, pull the telescopic runners ③ out as far as they will go.
- Place the freezer basket on the runners.
- Slide the basket all the way back in until it engages in the snap fastening.

Freezing fresh food

Fresh food should be frozen as quickly as possible so that the nutritional value of the food, its vitamin content, appearance and flavour are maintained.

Food which takes a long time to freeze will lose more water from its cells, which then shrink. During the defrosting process, only some of this water is reabsorbed by the cells. In practice this means that the food loses more moisture. You can see this in the large amount of water that collects around the food when it defrosts.

If food is frozen quickly, the cells have less time to lose moisture, so they shrink less. As there is much less moisture loss, it is easier for the food to reabsorb it during defrosting, and very little water collects around the defrosted food.

Storing frozen food

Never refreeze partially or fully defrosted food. Defrosted food may only be refrozen after it has been cooked.

When buying frozen food to store in your freezer, make sure to check:

- that the packaging is not damaged
- the use-by date and
- the temperature at which the frozen food is being stored at the store.

The length of time food can be kept is reduced if it has been stored at a temperature warmer than -18°C .

- Buy frozen food once you have finished the rest of your shopping, and wrap it in newspaper or use a cooler bag or cool box to transport it.
- Store it in the freezer as soon as possible after returning home.

Freezing and storing food

Home freezing

Only freeze food which is fresh and in good condition.

Tips on home freezing

- The following types of food **are suitable** for freezing:
Fresh meat, poultry, game, fish, vegetables, herbs, fresh fruit, dairy products, pastry, leftovers, egg yolks, egg whites and a range of pre-cooked meals.
- The following types of food **are not suitable** for freezing:
Grapes, lettuce, radishes, sour cream, mayonnaise, eggs in their shells, onions, whole raw apples and pears.
- To retain colour, taste and vitamin C, vegetables should be blanched before freezing. To blanch, immerse the trimmed and washed vegetables in boiling water for 2-3 minutes. Remove and plunge into ice-cold water to cool quickly. Drain and pack ready for freezing.
- Lean meat freezes better than fatty meat and can be stored for considerably longer.
- Separate chops, steaks, cutlets, schnitzel or rolled meat with a sheet of plastic freezer film. This prevents them from freezing together in a block.
- Do not season fresh foods or blanched vegetables before freezing. Only season cooked food lightly before freezing. The taste or intensity of some spices alters when frozen.
- Allow hot foods and drinks to cool down before placing them in the freezer. Placing hot foods or drinks in

the freezer causes food that is already frozen to partially thaw and increases energy consumption.

Packaging food for freezing

- Freeze food in portions.

Suitable packing material

- Plastic cling wrap
- Tubular polyethylene film
- Aluminum foil
- Freezer containers and bags

Unsuitable packing material

- Wrapping paper
- Grease-proof paper
- Cellophane
- Bin bags
- Plastic shopping bags
- Expel as much air as possible from bags etc. before sealing them to prevent freezer burn on food.
- Close the packaging tightly with
 - Rubber bands
 - Plastic clips
 - String or bag ties
 - Freezer tape

Useful tip: Freezer bags and tubular polyethylene film may also be sealed using home heat sealing kits.

- Label the packaging with the contents and the date of freezing.

Before placing food in the appliance

- When freezing more than 2 kg of fresh food, switch on the SuperFreeze function some time before placing the food in the freezer (see “Using SuperFreeze”).

Freezing and storing food

This helps food which is already stored in the freezer to stay frozen.

Placing food in the freezer

Food to be frozen can be placed anywhere in the freezer, preferably in the lowest freezer basket.

Place large quantities of food in the large freezer basket.

- Place the food to be frozen flat in the bottom of the basket so that it freezes through to the core as quickly as possible.
- Make sure that the packaging and containers are dry to prevent them sticking together when frozen.
- Please follow the guidelines in the table below regarding recommended weights for the baskets:

	Upper freezer basket	Lower freezer basket
F 2671 Vi	20 kg	20 kg

Unfrozen food should not touch frozen food as this will cause frozen food to begin to thaw.

Storage time for frozen food

The storage life of food varies greatly, even when a constant temperature of $-18\text{ }^{\circ}\text{C}$ is maintained. Even in frozen products, degradation processes take place, only at a much slower rate. For example, fat can become rancid from contact with oxygen in the air. Lean meat can therefore be stored approximately twice as long as fatty meat.

The storage times quoted are guide values for the storage life of different food groups in the freezer.

Food group	Storage time (months)
Ice cream	2 to 6
Bread, baked goods	2 to 6
Cheese	2 to 4
Fish, oily	1 to 2
Fish, lean	1 to 5
Sausage, ham	1 to 3
Game, pork	1 to 12
Poultry, beef	2 to 10
Vegetables, fruit	6 to 18
Herbs	6 to 10

Where the storage time given on the packaging differs, follow the advice on the packaging.

By keeping the freezer at a constant temperature of $-18\text{ }^{\circ}\text{C}$ and taking appropriate hygiene measures, you can maximize the storage life of your food and avoid food waste.

Freezing and storing food

Defrosting frozen food

Never refreeze partially or fully defrosted food. Defrosted food may only be refrozen after it has been cooked.

Frozen food can be defrosted in different ways:

- in a microwave oven
- in an oven using “Fan Heat” or the “Defrost” setting
- at room temperature
- in the refrigerator section (the cold given off by the frozen food helps to keep the other food cold)
- in a steam oven

Flat pieces of partially defrosted fish or meat can be placed directly into a hot frying pan.

Thicker pieces of meat and fish (e.g. minced beef, chicken, fish fillet) should not come into contact with other food when defrosting. Collect the defrosting liquid and then pour it away, making sure you wash the container it was in, the sink and your hands.

Fruit should be defrosted at room temperature in its packaging or in a covered bowl.

Most vegetables can be cooked while still frozen. Just put straight into boiling water or hot fat. The cooking time is slightly less than that of fresh vegetables due to changes in the cell structure.

Cooling drinks quickly

When cooling drinks quickly in the freezer, make sure bottles are **not left in for more than one hour**, otherwise they could burst, causing injury and damage.

Operating the Ice/Water dispenser

The Ice/Water dispenser requires a mains water connection in order for it to operate (see “Installation – Water connection”).

If you do not dispense chilled water or ice from the Ice/Water dispenser for a long period of time, the water/ice may become stale. Regularly dispense water/ice in order to achieve the best water quality.

Risk of injury from broken glass.
Use a sturdy container for collecting water and ice cubes.

 Risk of injury due to incorrect handling.
Risk of injury from holding your hands under the Ice/Water dispenser.
Do not hold your hands under the Ice/Water dispenser.

 Risk of injury due to incorrect handling.
Risk of injury from reaching into the discharge opening of the ice cube container.
Never reach into the discharge opening of the ice cube container.

 Risk to health due to contaminated water.
The consumption of polluted water can lead to health problems.

The first 5 glasses of chilled water and the first 30–40 ice cubes made after the Ice/Water dispenser is started up must not be consumed, as the water will have been used for the initial rinsing of the water supply line. This applies to using it for the first time as well as when using the appliance again after it has been switched off for a long time.

 Risk of damage due to blocking of the ice cube maker.
The ice maker can become blocked and, as a result, be damaged.
Do not place any bottles or food into the ice cube container to chill them quickly.

If the Ice/Water dispenser is not used again within 2 minutes or if the appliance door is opened, the Ice/Water dispenser will switch to standby mode automatically and the lighting will go out.
After it has been activated again, it can take a few seconds before chilled water and ice is dispensed again.

Operating the Ice/Water dispenser

Switching the Dispenser unit on

Ice cubes can only be made when the ice cube container is completely closed.

- In Settings mode , use the < and > sensors to select Dispenser unit and touch *OK* to confirm your selection.
- Use the < and > sensors to select On and confirm your selection with *OK*.
- Close the appliance door.

The Ice/Water dispenser is now ready for operation.

All sensors in the Ice/Water dispenser control panel should now be highlighted in white.

If this is not the case, the system lock has been activated (the  sensor will be highlighted in white; see “Operating the Ice/Water dispenser – Switching the system lock on/off”).

Once the freezer has cooled down to its set temperature, the ice cube maker will fill with water.

As soon as the water is frozen, ice cubes will fall out of the ice cube maker into the ice cube container.

Ice cube production is halted automatically when the ice cube container is full.

After the Ice/Water dispenser has been switched on, it can take up to 24 hours until the first serving of ice cubes is ready.

After the appliance door has been opened and closed, it can take several seconds until the Ice/Water dispenser is ready for operation and the sensors can be operated again.

Dispensing chilled water

After the initial commissioning, there may be air in the water circuit. Dispense water until there are no more air bubbles.

All materials used in the Ice/Water dispenser are odourless and do not affect flavour.

If you dispense chilled water again after a long period of time, the water may be stale. In this case, pour away the first 15 glasses of water.

Regularly dispense water/ice in order to obtain the best water quality.

- Place a sturdy container under the Ice/Water dispenser.



- Press and hold the chilled water sensor.

Chilled water will be dispensed from the spout as long as the sensor is pressed. After approx. 30 seconds, dispensing is ended automatically. If you wish to dispense more water, wait 5 seconds and then press the sensor again.

If you want the water to be colder, dispense ice cubes into the container beforehand.

If a large amount of water is dispensed, the water can become warmer.

Operating the Ice/Water dispenser

Dispensing ice cubes and crushed ice

After the Ice/Water dispenser has been switched on, it can take up to 24 hours until the first serving of ice cubes is ready.

- Place a sturdy container under the Ice/Water dispenser.



- Press and hold the sensor for ice cubes or crushed ice.

Ice will be dispensed from the spout as long as the sensor is pressed.

After approx. 30 seconds, dispensing is ended automatically. If you wish to dispense more ice, wait 5 seconds and then press the sensor again.

- Take your finger off the sensor when the container is almost full. Otherwise it will overflow or the ice will block the spout.

The ice cube maker can make up to approx. 2.4 kg of ice cubes in 24 hours.

The amount of ice cubes produced depends on the temperature in the freezer. **The lower the temperature, the more ice cubes are produced within a given time.**

Empty and clean the ice cube container at regular intervals, or at least when you have not produced any ice cubes for longer than a week (see “Cleaning and care – Emptying and cleaning the ice cube container”).

This will ensure that you always have fresh ice cubes, and the ice cubes will not clump together.

Switching the Dispenser unit off

- Turn off the tap of the water supply approx. 3 hours before switching off the refrigeration appliance to avoid the build-up of mould caused by stagnant water.
- In Settings mode , use the < and > sensors to select Dispenser unit and touch OK to confirm your selection.
- Use the < and > sensors to select Off and confirm your selection with OK.

The Ice/Water dispenser is now switched off; the sensors in the control panel are no longer highlighted in white.

Operating the Ice/Water dispenser

Switching the system lock on/off

You can use the system lock to protect the Ice/Water dispenser from unauthorised use, such as by children.



- Touch the  sensor until it is highlighted in white and a short tone sounds.

The remaining sensors of the Ice/Water dispenser are now locked and cannot be selected.

- To switch off the system lock, touch the  sensor for approx. 3 seconds until it is no longer highlighted in white and a short tone sounds.

Automatic defrosting

The appliance is equipped with a "NoFrost" system. The freezer defrosts automatically.

The moisture generated in the appliance collects on the evaporator and is automatically defrosted and dissipated from time to time.

This automatic defrosting system enables the freezer to remain permanently ice-free. Food stored in the freezer will not defrost with this system.

Cleaning and care

Do not let water get into the electronic unit or the lighting.

 Risk of damage due to moisture ingress.

The steam from a steam cleaning appliance can damage plastic parts and electrical components.

Do not use a steam cleaner to clean the appliance.

The data plate located inside the refrigeration appliance must not be removed. It contains information which is required in the event of a fault.

Cleaning agents

To avoid damaging the surfaces of your appliance, **do not use:**

- cleaning agents containing soda, ammonia, acids or chlorides
- cleaning agents containing descaling agents
- abrasive cleaning agents, e.g. powder cleaners and cream cleaners
- solvent-based cleaning agents
- stainless steel cleaning agents
- dishwasher cleaner
- oven sprays
- glass cleaning agents
- hard, abrasive sponges and brushes, e.g. pot scourers
- dirt erasers
- sharp metal scrapers.

Cleaning and conditioning agents used in the interior of the refrigeration appliance must be food safe.

We recommend using lukewarm water with a little dishwashing liquid to clean the appliance.

The drip tray grille, back and frame of the Ice/Water dispenser are finished with a high-quality surface coating. It is resistant to soiling and easy to clean.

 Risk of damage due to incorrect cleaning and maintenance.
The surface coating will be damaged.
Do **not** treat the drip tray grille, back and frame of the Ice/Water dispenser with

- stainless steel cleaning agents:
The coating will be damaged.
- Miele care product for stainless steel:
This will cause noticeable smearing.

 Risk of damage due to incorrect cleaning.
The surface coating will be damaged.
Do not clean the drip tray or the drip tray grille of the Ice/Water dispenser in the dishwasher.

 Risk of damage caused by adhesives.
Adhesives will damage the surface coating, causing it to lose its dirt-repellent properties.
Do not adhere sticky notes, transparent tape, masking tape or other adhesives to parts of the Ice/Water dispenser.

Before cleaning the appliance

- Switch the appliance off by pressing the On/Off switch.
- Take any food out of the appliance and store it in a cool place.
- Take out all other removable parts for cleaning (see "Adjusting the interior fittings").

Cleaning and care

Cleaning the interior and accessories

Clean the appliance regularly, or at least once a month.

Remove soiling immediately to prevent it from drying on.

- Clean the interior with a solution of lukewarm water and a little dishwashing liquid. Rinse all parts by hand. Do not wash in a dishwasher.
- After cleaning, wipe with a damp cloth and dry with a soft cloth.
- Leave the door open for a short time to air out the appliance and avoid the formation of odours.

Aluminium frames

The frames on the shelves are partially made from aluminium.

Aluminium is a dynamic material. The reflection and appearance of aluminium changes in different lights and environments and depending on the angle you view it from. It is also susceptible to scratching.

The aluminium frames may become discoloured or get damaged if soiling is left on for too long.

Remove any soiling from the aluminium frames immediately.

Emptying and cleaning the ice cube container

Clean the ice cube container regularly. This ensures that fresh ice cubes are always produced.

Empty the ice cube container on a regular basis. This prevents ice cubes from freezing together.

The ice cube container is very heavy when filled. Pull it out using both hands.

- Open the appliance door.

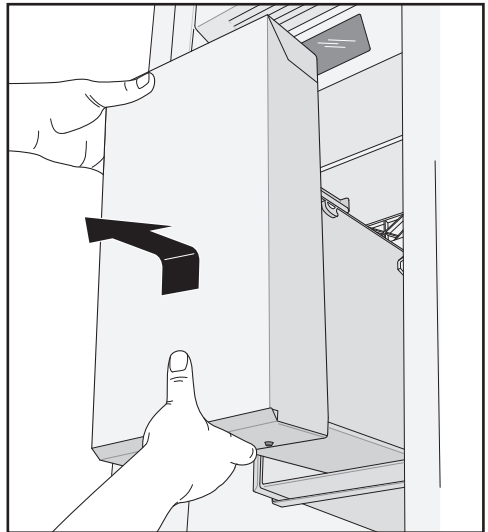

- Lift the ice cube container with both hands and pull it forwards to remove it from the refrigeration appliance.
- Empty the ice cube container and rinse it with warm water.
- Dry the ice cube container thoroughly so that new ice cubes will not freeze onto the surfaces.

- To reinsert the ice cube container, push it into the refrigeration appliance until it clicks into position.
- If you cannot push the ice cube container back in all the way, turn the screw conveyor inside a little.

Cleaning the drip tray

The drip tray catches excess water.

To avoid a build-up of odour, the drip tray should be cleaned every day.

- Remove the drip tray grille.
- Remove the drip tray and clean it.
- Dry the drip tray with a cloth.
- Reinsert the drip tray and the drip tray grille.

Cleaning the door seal

 Risk of damage due to incorrect cleaning.

If you treat the door seal with oils or grease, it can become porous.

Do not use any oils or grease on the door seals.

- The door seal should be cleaned regularly with clean water, and then wiped dry with a soft cloth.

Cleaning the ventilation gaps

A build-up of dust will increase the energy consumption of the appliance.

- The ventilation gaps should be cleaned on a regular basis with a brush or vacuum cleaner (you could use a Miele Vacuum Cleaner dusting brush, for example).

Cleaning and care

Cleaning the water filter (IntensiveClear mesh filter)

Depending on the quantity of ice cubes produced, the IntensiveClear mesh filter must be cleaned approx. every 6 months.

Clean the water filter appears in the display.

- Confirm the message with *OK*.

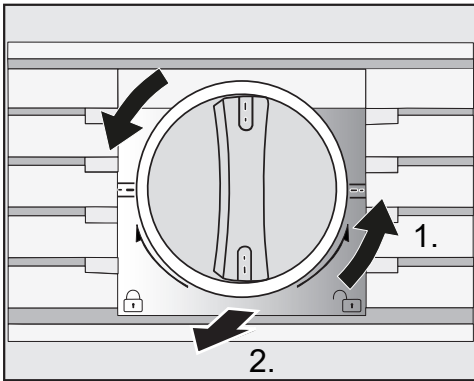

- Turn the cap of the filter cartridge anti-clockwise until it is in the vertical position 1.) and slide it out of the filter opening 2.).

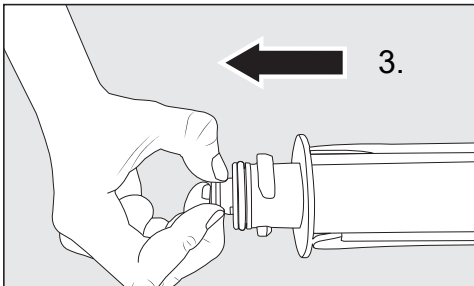

- Pull the mesh out of the back of the filter cartridge 3..

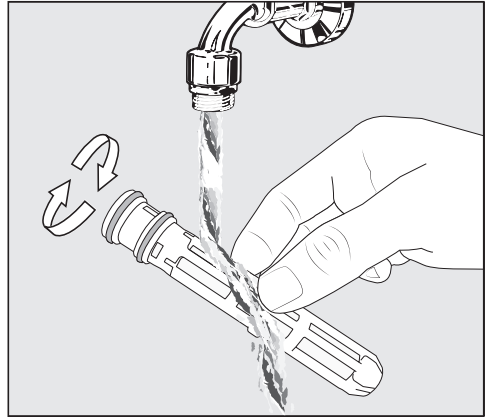

- Rinse the mesh under lukewarm running water. Turn the mesh over under the running water to clean it on all sides.

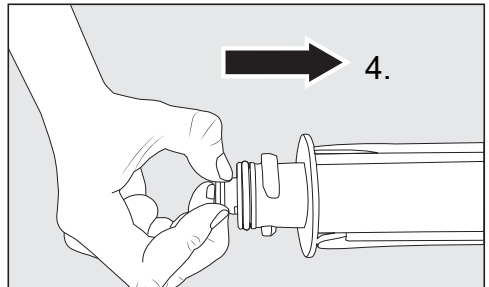

- Reinsert the mesh into the back of the filter cartridge 4..

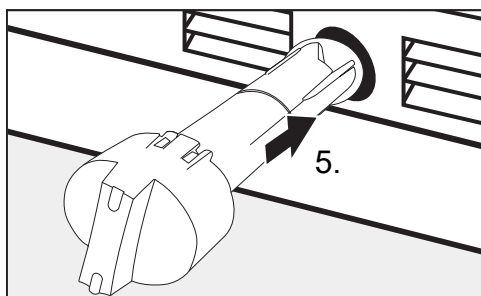

- Slide the filter cartridge as far as it will go into the filter opening 5.), making sure the cap is vertical.

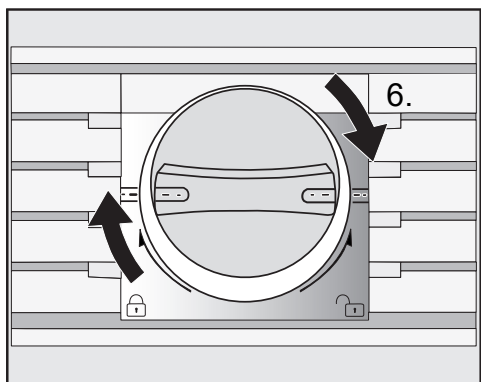



- Turn the cap of the filter cartridge clockwise until it is in the horizontal position 6.).



 Risk of damage caused by water running out.

If the filter cartridge is not fitted correctly, there is a risk of water leaking out of the appliance.

When fitting the filter cartridge, be sure to turn it as far as the marker.

Once the IntensiveClear mesh filter has been cleaned, the water filter display  must be reset via the Settings mode  in the display (see "Selecting further settings - Resetting the Water filter display ").

After cleaning

- Refit all shelves and accessories in the appliance.
- Switch the appliance on again.
- Switch the SuperFreeze  function on for a while so that the freezer can cool down quickly.
- Once the freezer has reached the required temperature, place the frozen food back in the freezer baskets.
- Switch the SuperFreeze  function off as soon as the temperature in the freezer is a constant $-18\text{ }^{\circ}\text{C}$ or colder.

Water filter

The refrigeration appliance is supplied with a water filter (IntensiveClear mesh filter) that filters mains water for making ice cubes.

The IntensiveClear mesh filter filters suspended particles from the mains water – not bacteria or microbes.

The water filter does not need to be replaced. However, to ensure the highest quality of the ice cubes, it is essential to clean the water filter regularly.

After inserting a new water filter, dispose of all ice cubes produced in the next 24 hours following the change.

Depending on the quantity of ice cubes produced, the IntensiveClear mesh filter must be cleaned approx. every 6 months.

Clean the water filter appears in the display.

- Clean the IntensiveClear mesh filter (see “Cleaning and care - Cleaning the water filter (IntensiveClear mesh filter)”).

Problem solving guide

Many malfunctions and minor faults that can occur in daily operation can be corrected without contacting Miele. This will save you time and money because you will not need a service call.

You can find information on how to remedy faults yourself at www.miele.com.au/service or www.miele.co.nz/service and on the Miele website.

Please note, however, that a call-out charge will be applied to unnecessary service visits where the problem could have been rectified as described in these operating instructions.

To prevent cold from escaping, avoid opening the appliance door until the fault has been corrected.

Problem	Possible cause and remedy
<p>If you feel that your refrigeration appliance is not working properly, you can perform a Self test. Your appliance will be checked for any faults or malfunctions.</p>	<p>Any errors identified during the Self test are shown in the display.</p> <ul style="list-style-type: none"> ■ Perform the Self test (see “Selecting further settings - Carrying out a Self test <input checked="" type="checkbox"/>”). ■ If necessary, contact customer service and inform them of the error message(s) in the display.
<p>The refrigeration appliance is not getting cold and the interior lighting does not come on when the appliance door is opened.</p>	<p>The appliance is not switched on.</p> <ul style="list-style-type: none"> ■ Switch the appliance on. The temperature appears in the display.
	<p>The plug is not properly inserted into the socket or the socket is not switched on.</p> <ul style="list-style-type: none"> ■ Insert the plug into the socket correctly and switch on.
	<p>The mains circuit breaker has tripped. There could be a fault with the appliance, the household electrical wiring or another electrical appliance.</p> <ul style="list-style-type: none"> ■ Contact a qualified electrician or Miele.







Problem solving guide

Problem	Possible cause and remedy
<p>The compressor is switching on more frequently and for longer periods of time. The temperature in the appliance is too low.</p>	<p>The ventilation gaps in the housing unit are covered or have become too dusty.</p> <ul style="list-style-type: none"> ■ Do not block the ventilation gaps. ■ Clean the dust from the ventilation gaps on a regular basis.
	<p>The appliance door has been opened too frequently, or a large amount of fresh food has been placed inside or frozen at the same time.</p> <ul style="list-style-type: none"> ■ Only open the door when necessary and for as short a time as possible. <p>After a while the temperature will return to normal by itself.</p>
	<p>The appliance door is not properly closed. A thick layer of ice may have formed in the freezer.</p> <ul style="list-style-type: none"> ■ Close the appliance door. <p>After a while the temperature will return to normal by itself.</p> <p>If a thick layer of ice has formed, it will decrease the cooling performance and increase the energy consumption.</p> <ul style="list-style-type: none"> ■ Defrost the appliance and clean it.
	<p>The ambient room temperature is too high. The higher the room temperature, the longer the compressor will run.</p> <ul style="list-style-type: none"> ■ See the information in "Installation - Location".
	<p>The refrigeration appliance was not properly installed in the niche.</p> <ul style="list-style-type: none"> ■ See the information in "Installation" and "Installing the appliance".



Problem solving guide

Problem	Possible cause and remedy
<p>The compressor is switching on more frequently and for longer periods of time. The temperature in the appliance is too low.</p>	<p>The temperature setting is too low. ■ Correct the temperature setting.</p>
	<p>The door is not properly closed. ■ Check whether the appliance door closes properly.</p>
	<p>A large amount of food was placed in the freezer at once. ■ See "Freezing and storing food".</p>
	<p>The SuperFreeze function is still switched on. ■ To save energy, you can switch the SuperFreeze function off earlier.</p>
<p>The compressor comes on less and less often and for shorter periods of time. The temperature in the appliance rises.</p>	<p>This is not a fault. The temperature setting is too high. ■ Correct the temperature setting. ■ Check the temperature again after 24 hours.</p>
	<p>The frozen food begins to defrost. The ambient temperature is too low for this refrigeration appliance. If the ambient temperature is too low, the compressor will run less frequently. This may cause the freezer to become too warm. ■ See the information in "Installation - Installation location". ■ Increase the ambient temperature.</p>
<p>The compressor runs continuously.</p>	<p>This is not a fault. To save energy, the compressor runs at a lower speed when less cooling is required. This increases the running time of the compressor.</p>
<p>Food has frozen together.</p>	<p>The food packaging was not dry when loaded in the freezer. ■ Use a blunt instrument, e.g. a spoon handle or plastic scraper, to prise it apart carefully.</p>
<p>An alarm sounds.</p>	<p>The appliance door has been open for longer than 2 minutes. ■ Close the appliance door.</p>





Problem solving guide

Problem	Possible cause and remedy
<p>No alarm sounds despite an appliance door being open.</p>	<p>You have deactivated the alarm.</p> <ul style="list-style-type: none"> ■ Switch the alarm back on via the Settings mode . <p>The Sabbath mode  function is switched on: The temperature display is dark and the  symbol is shown in the display.</p> <ul style="list-style-type: none"> ■ You can switch off Sabbath mode at any time (see "Selecting further settings - Switching Sabbath mode  on and off").
<p>The door of the appliance cannot be opened.</p>	<p>The Pull2open Door assistant is switched on but the appliance has a handle-free furniture front.</p> <ul style="list-style-type: none"> ■ With handle-free furniture fronts, switch on the Push2open Door assistant (see "Selecting further settings - Switching on the Door assistant ").
<p>The appliance door cannot be opened when Sabbath mode  is switched on.</p>	<p>The Push2open Door assistant is switched on at the same time as Sabbath mode.</p> <ul style="list-style-type: none"> ■ When Sabbath mode is switched on, the Door assistant is deactivated. ■ Pull the door open from the bottom or from the side.

Messages in the display

Message	Possible cause and remedy
<p>The alarm sounds and the message Freezer temperature too high. Max. temperature °C appears in the display.</p>	<p>The temperature in the freezer has risen significantly. This could be due to, for example:</p> <ul style="list-style-type: none"> – the freezer door being opened too often, or being left open – a large amount of food being frozen at once – an interruption to the power supply. <p>■ If you find the alarm disruptive, you can switch it off early by touching the <i>OK</i> sensor.</p> <p>The alarm will stop.</p> <p>■ Rectify the cause of the alarm.</p> <p>The message will disappear from the display and the alarm will stop.</p> <p>The temperature display will show the highest temperature that was reached in the freezer zone.</p> <p>■ Depending on the temperature displayed, you should check whether food in the freezer has started to thaw or has defrosted. Defrosted food may only be refrozen after it has been cooked.</p> <p>■ In the event of a power cut, check whether there are any ice cubes in the ice cube container and dispose of these. Otherwise, the ice cubes will freeze together and can damage the ice cube container when they expand.</p>
<p>The alarm sounds and the message Close the door appears in the display.</p>	<p>The appliance door is open.</p> <ul style="list-style-type: none"> ■ Close the appliance door. ■ If you want to switch the alarm off early, touch the <i>OK</i> sensor in the display. <p>The alarm will stop.</p>
<p>The temperature display is dark and the  symbol lights up in the display.</p>	<p>Sabbath mode  is switched on. The interior lighting is switched off and the refrigeration appliance is cooling.</p> <p>■ You can switch off Sabbath mode at any time (see “Selecting further settings - Switching Sabbath mode  on and off”).</p>

Problem solving guide

Message	Possible cause and remedy
F Please call Miele Service appears in the display and an alarm sounds.	There is a fault. <ul style="list-style-type: none"> ■ Make a note of the fault message if necessary. ■ Call Miele. ■ To switch the alarm off, touch the  symbol. The fault message will not disappear from the display until the fault has been rectified.
The  symbol lights up in the display. The refrigeration appliance does not get cold, but the appliance controls are working.	Demo mode  is switched on. Demo mode allows the appliance to be presented in a showroom without the cooling system being switched on. Do not activate this setting for domestic use. <ul style="list-style-type: none"> ■ Switch off Demo mode  (see “Selecting further settings - Switching off Demo mode ”).

Problems with the Ice/Water dispenser

Problem	Possible cause and remedy
The Ice/Water dispenser cannot be switched on.	The refrigeration appliance is not connected to the power supply. <ul style="list-style-type: none"> ■ Check that the refrigeration appliance is connected to the electricity supply.
	The system lock of the Ice/Water dispenser is active (the  sensor is highlighted in white). <ul style="list-style-type: none"> ■ Switch off the system lock (see “Operating the Ice/Water dispenser – Switching the system lock on/off”).
The Ice/Water dispenser is not immediately ready for operation after having been switched on.	This is not a fault. After the appliance door has been opened and closed, it can take several seconds until the Ice/Water dispenser is ready for operation.

Problem solving guide

Problem	Possible cause and remedy
No ice cubes are dispensed.	<p>The Ice/Water dispenser spout is blocked by clumps of ice.</p> <ul style="list-style-type: none">■ Remove the ice that has clumped together.■ Empty the ice cube container at the latest if you have not produced any ice cubes for a week (see “Cleaning and care – Emptying and cleaning the ice cube container”). <p>After the Ice/Water dispenser has been switched on, it can take up to 24 hours until the first serving of ice cubes is ready.</p>
The chilled water from the Ice/Water dispenser does not taste good.	<p>If you dispense chilled water again after a long period of time, it may be stale.</p> <ul style="list-style-type: none">■ In this case, pour away the first 15 glasses of water.

Problem solving guide

Problems with the ice cube maker

Problem	Possible cause and remedy
The ice cube maker is not producing any ice cubes or no chilled water is being dispensed.	The appliance or the Ice/Water dispenser has not been switched on. <ul style="list-style-type: none">■ Make sure that the appliance is switched on.■ Make sure that the Ice/Water dispenser is switched on.
	The mains water connection has not been installed. <ul style="list-style-type: none">■ Make sure that the mains water connection is installed correctly.
	The tap is not turned on or has not been vented. <ul style="list-style-type: none">■ Turn on the tap.■ Check whether the water supply has been vented.
	There is a kink in the water hose. <ul style="list-style-type: none">■ Check the water hose and replace it if necessary.
	The temperature in the freezer is too high. <ul style="list-style-type: none">■ Set the temperature in the freezer lower (see “The correct temperature”).
	The freezer door has been opened too frequently, causing the compressor to turn on more often and the ice cube maker has iced up. <ul style="list-style-type: none">■ Only open the door when necessary and for as short a time as possible.
	The water pressure is too low. <ul style="list-style-type: none">■ Check whether the water pressure is between 200 kPa and 800 kPa (2 bar and 8 bar).■ Check if an incorrect valve has been installed, making the pressure too low.
	After the Ice/Water dispenser has been switched on, it can take up to 24 hours until the first serving of ice cubes is ready.





Problem solving guide

Problem	Possible cause and remedy
<p>The ice cube maker is only producing small ice cubes.</p>	<p>Several household appliances connected to the mains water connection are in operation. This has reduced the amount of water being taken in.</p> <ul style="list-style-type: none"> ■ Avoid using the dishwasher, washing machine, etc. at the same time.
	<p>The water filter is clogged.</p> <ul style="list-style-type: none"> ■ Check whether the water filter needs to be cleaned.
	<p>The water connection pressure is too low.</p> <ul style="list-style-type: none"> ■ Check that the water connection pressure is between 200 kPa and 800 kPa (2 bar and 8 bar). ■ Check if an incorrect valve has been installed.
<p>The ice cube maker is producing only a few or deformed ice cubes or only a little cold water is being dispensed.</p>	<p>The water filter is clogged.</p> <ul style="list-style-type: none"> ■ Check whether the water filter needs to be changed or cleaned.
	<p>The water pressure is too low.</p> <ul style="list-style-type: none"> ■ Check whether the water pressure is between 200 kPa and 800 kPa (2 bar and 8 bar).
	<p>The temperature in the freezer is too high.</p> <ul style="list-style-type: none"> ■ Set a lower temperature.
<p>The ice cubes taste or smell odd.</p>	<p>The ice cube container is in constant use and needs to be cleaned regularly.</p> <ul style="list-style-type: none"> ■ Check if the ice cube container is dirty and clean it if necessary.
	<p>The ice cube maker is rarely used. Ice cubes that are stored for a long time can absorb the taste and smell of other items.</p> <ul style="list-style-type: none"> ■ Empty and clean the ice cube container if you are not going to use it for a long time.
	<p>Unwrapped food is stored in the freezer zone. Ice can absorb the taste and smell of unwrapped food.</p> <ul style="list-style-type: none"> ■ Only store packaged food in the freezer zone.
	<p>The water filter is dirty.</p> <ul style="list-style-type: none"> ■ Check whether the water filter needs to be cleaned.

Problem solving guide

Problem	Possible cause and remedy
Water is flowing out of the appliance.	<p>The water intake is faulty.</p> <ul style="list-style-type: none">■ Close the tap immediately.■ Check the water pipe for damage.■ Call Miele immediately.■ Check whether the water pressure is too high. <hr/> <p>If the water pressure is too high, this can cause leaks (see “Installation - Water connection”).</p> <ul style="list-style-type: none">■ Check whether the water pressure is between 200 kPa and 800 kPa (2 bar and 8 bar).■ Check if an incorrect valve has been installed.

The interior lighting is not working

Problem	Possible cause and remedy
<p>The interior lighting is not working.</p>	<p>The appliance is not switched on.</p> <ul style="list-style-type: none"> ■ Switch the appliance on.
	<p>The Sabbath mode function is switched on: The temperature display is dark and the  symbol lights up in the display.</p> <ul style="list-style-type: none"> ■ You can switch off Sabbath mode at any time via the Settings mode .
	<p>There is a fault.</p> <div style="border: 1px solid gray; padding: 10px;"> <p> Risk of electric shock due to exposed, live electrical components!</p> <p>When removing the lighting cover, there is a risk of coming into contact with live electrical components.</p> <p>Do not remove the lighting cover. The LED lighting must only be repaired or replaced by a qualified technician.</p> </div>
	<div style="border: 1px solid gray; padding: 10px;"> <p> Danger of injury from LED lighting.</p> <p>This lighting corresponds to risk group RG 2. If the cover is defective, there is a risk of eye injury.</p> <p>If the lighting cover is defective, do not look from a close range directly into the lighting with optical instruments (e.g. magnifying glass or similar).</p> </div> <ul style="list-style-type: none"> ■ Call Miele.

Noises

Normal noises	What causes them
Brrrrr ...	A humming noise is made by the compressor. This noise can get louder for brief periods when the compressor switches on.
Blubb, blubb ...	A gurgling noise can be heard when coolant is circulating through the pipes.
Click ...	Clicking sounds occur whenever the thermostat switches the compressor on or off.
Sssrrrrr ...	You can sometimes just hear the sound of the fan inside the appliance.
Crack ...	A cracking sound can be heard when materials expand inside the appliance.
Please bear in mind that the noise of the compressor and the coolant circulating in the system is unavoidable.	

Noises	Possible cause and remedy
Rattling, vibrating, clinking	The refrigeration appliance is uneven. Realign the appliance using a spirit level. Do so by raising or lowering the adjustable feet underneath the refrigeration appliance.
	The refrigeration appliance is touching another appliance or piece of furniture. Move it away.
	Drawers, baskets or shelves are jiggling or are stuck. Check all removable items and refit them correctly.
	Bottles or containers are touching. Separate them.

You can find information on how to remedy faults yourself and about Miele spare parts at www.miele.com.au/service or www.miele.co.nz/service.

Contact in case of fault

In the event of a fault which you cannot remedy yourself, please contact Miele.

You can book a Miele customer service call-out online at www.miele.com.au/service or www.miele.co.nz/service.

Contact information for Miele can be found at the end of this booklet.

Please quote the model and serial number of your appliance when contacting Miele. Both of these can be found on the data plate inside the refrigeration appliance or, depending on the model, in the settings mode under information **i**.

The data plate is located inside the refrigeration appliance.

Warranty

The manufacturer's warranty for this appliance is 2 years.

For further information, please refer to your warranty booklet.

Copyright and licences

For the purpose of operating and controlling the appliance, Miele uses proprietary or third-party software that is not covered by open source licensing terms. These items of software/software components are protected by copyright. The copyright powers of Miele and third parties must be respected.

In addition, the appliance contains software components which are distributed under open source licensing terms. You can view these open source components along with the associated copyright notices, copies of the valid licensing terms and any further information in the document "Open Source Information and Licenses". The liability and warranty arrangements for the open source licences displayed at this location only apply in relation to the respective rights holders.

The appliance contains, in particular, software components which are licensed by the rights holders under the GNU General Public License, version 2, or the GNU Lesser General Public License, version 2.1. For a period of at least 3 years following the purchase or delivery of the appliance, Miele shall provide you or third parties with a machine-readable copy of the source code for the open source components contained in the appliance, which are licensed under the terms of the GNU General Public License, version 2, or the GNU Lesser General Public License, version 2.1. The source code shall be made available on a data carrier (CD-ROM, DVD or USB stick). To obtain this source code, please contact us, specifying the product name, serial number and purchase date, by sending us an e-mail (info@miele.com) or writing to the following address:

Miele & Cie. KG
Open Source
GTZ/TIM
Carl-Miele-Straße 29
33332 Gütersloh, Germany

We wish to draw your attention to the limited warranty for the benefit of rights owners under the terms of the GNU General Public License, version 2, and the GNU Lesser General Public License, version 2.1:

This program is distributed in the hope that it will be useful, but WITHOUT ANY WARRANTY, without even the implied warranty of MERCHANTABILITY of FITNESS FOR A PARTICULAR PURPOSE. See the GNU General Public License and GNU Lesser General Public License for more details.

Miele Australia Pty. Ltd.

ACN 005 635 398

ABN 96 005 635 398

Level 4, 141 Camberwell Road
Hawthorn East, VIC 3123

1300 464 353 (1300 4 MIELE)

info@miele.com.au

www.miele.com.au

Miele New Zealand Limited

IRD 98 463 631

8 College Hill
Freemans Bay, Auckland 1011

0800 464 353 (0800 4 MIELE)

customercare@miele.co.nz

www.miele.co.nz

Miele Global Headquarters

Germany

Miele & Cie. KG

Carl-Miele-Straße 29

33332 Gütersloh

Federal Republic of Germany

F 2671 Vi

en- AU, NZ

M.-Nr. 11 618 791 / 00