

Miele



Installation plan Commercial Washing Machine PWM 920 EL

To avoid the risk of accidents or damage to the appliance, it is **essential** to read these instructions before it is installed and used for the first time.







en-AU,NZ

M.-Nr. 12 052 500

Contents

Installation notes	3
Explanation of the safety instructions and warnings on the machine.....	3
Installation requirements	3
General operating conditions	3
Installation	4
Installation on concrete plinth	4
Levelling the machine.....	4
Securing the machine.....	5
Electrical connection	5
Water connection	6
Cold water connection	6
Hot water connection	7
Drain valve.....	7
Dispenser pump connections	8
Optional accessories.....	9
Hard water kit (APWM062)	9
APWM 019/020 - Connector Box.....	9
WLAN/LAN interface	11
Plinth (APWM031/035)	11
Vapour and foam venting kit (APWM 063)	11
Installation	12
Standard.....	12
Plinth	14
Installation	16
Standard.....	16
Plinth	17
Floor anchoring	18
Technical data	19
Voltage versions and electrical data.....	19
Water connection	20
Cold water connection	20
Hot water connection	20
Hard water connection (optional)	20
Drainage	20
Connection for equipotential bonding.....	20
Installation dimensions.....	20
Anchoring	21
Transport data, weight and floor load	21
Models with detergent drawer (DD).....	21
Emissions data	21

Explanation of the safety instructions and warnings on the machine

	Read the operating instructions
	Read the instructions e.g. installation instructions
	Warning: hot surfaces
	Caution: voltage up to 1000 volts
	Earthing
	Equipotential bonding

Installation requirements

The washing machine must be installed and commissioned by a Miele Service technician or by an authorised service technician.

- ▶ The washing machine must be installed in accordance with applicable regulations and standards. Local energy and water supplier regulations must also be observed.
- ▶ This washing machine must only be operated in a room that has sufficient ventilation and which is frost-free.

This machine should not be installed or operated in any area where there is a risk of explosion.

General operating conditions

This washing machine is intended only for use in a commercial environment and must only be operated indoors.

- Ambient temperature: 0-40 °C
- Relative humidity: non-condensing
- Maximum height above sea level of installation site: 2000 m

Depending on the nature of the installation site, sound emissions and vibration may occur.

Useful tip: Have the installation site inspected and seek the advice of a professional in instances where increased noise may cause a nuisance.

Installation notes

Installation

Transport the washing machine to its installation site using a suitable pallet truck and remove the transport packaging.

The washing machine must be set up on a completely level, horizontal and firm surface with the minimum stated load bearing capacity (see "Technical data").

Useful tip: A concrete floor is the most suitable installation surface. It is far less prone to vibration during the spin cycle than wooden floorboards or a carpeted surface.

The floor load created by the washing machine is concentrated and transferred to the installation footprint via the surface load in the area of the contact patch.

The washing machine requires a gap of at least 50 mm on each side to allow for movement during operation. Please ensure a minimum distance of 400 mm is maintained between the rear of the appliance and the rear wall.

The washing machine must not be installed on a carpeted floor.

The feet of the washing machine must be secured to the 4 fastening points on the floor using the fittings supplied.

The fastening material provided is intended for use in bolting the machine to a concrete floor. If other floor types are present at the installation site, the fastening material must be ordered by the customer.

Installation on concrete plinth

The washing machine can be installed on a concrete plinth if desired.

The concrete materials and the durability of the concrete plinth must be assessed in accordance with the floor load bearing capacity given in "Technical data".

- To guarantee the stability of the washing machine, make sure that the concrete plinth is sufficiently stable on the floor and that it is capable of withstanding any burden or force from the washing machine.
- The washing machine must be secured to the concrete plinth using the fixtures and fastenings supplied.

 The washing machine must be secured to the plinth immediately after installation!

There is a risk of the washing machine falling off a raised plinth during a spin cycle if it is not secured.

Levelling the machine

- Align the washing machine vertically and horizontally using the adjustable feet and a spirit level.

The washing machine must stand evenly and horizontally on all four feet to ensure trouble-free and energy-efficient operation. Otherwise the water and energy consumption increases and the washing machine might move around.

- After aligning the machine, tighten the counter nuts by turning them in an anti-clockwise direction with a spanner. This will prevent the feet from adjusting themselves.

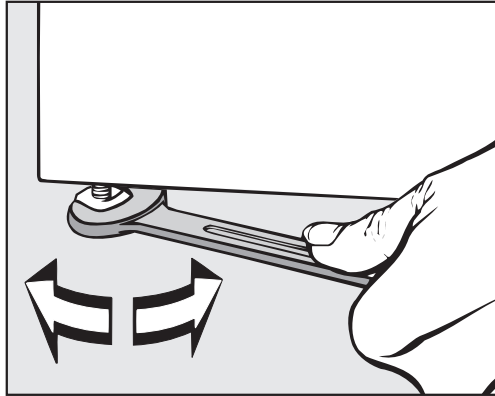

Securing the machine

- The feet of the washing machine must be secured to the concrete plinth using the fixtures and fastenings supplied.

The material provided is intended for use in bolting the machine to a concrete floor. For other types of flooring, please purchase suitable fitting materials separately.

Electrical connection

The electrical connection must be carried out by a qualified electrician who must ensure that all electrical work is carried out in accordance with applicable electrical regulations and standards.

- ▶ This washing machine must be connected to an electrical mains supply that complies with local and national regulations. Please also observe your insurance and energy supplier's regulations as well as any workplace health and safety regulations.
- ▶ The required voltage, rated load and fusing rating can be found on the data plate on the washing machine. Before connecting the machine to the electricity supply, please ensure that the mains supply voltage complies with the values given on the data plate.

Connection to a supply voltage other than the one quoted on the data plate can lead to functional faults and damage to the washing machine.

If more than one voltage is quoted on the data plate, the washing machine can be converted for connection to the voltages stated.

Installation notes

► Conversion to a different voltage must only be carried out by a Miele Professional Service technician or by an authorised service technician. The wiring instructions given on the wiring diagram must be followed.

The machine is intended for hard-wiring, but can be connected using a plug and socket.

For hard-wired machines, connection should be made via a suitable mains switch with all-pole isolation which, when in the off position, ensures a 3 mm gap between all open contacts. These include circuit breakers, fuses and relays.

If the mains supply cannot be permanently disconnected, the isolator switch (including plug and socket) must be safeguarded against being switched on either unintentionally or without authorisation.

An electrical safety test must be carried out after installation and after any service work.

► If it is necessary to install a residual current device (RCD) in accordance with local regulations, a residual current device type B (sensitive to universal current) must be used.

An existing type A residual current device (RCD) must be exchanged for a type B RCD.

► If necessary, equipotential bonding with a good contact connection must be guaranteed in compliance with all applicable local and national installation specifications.

Equipotential bonding must have an earth current rating > 10 mA. Accessories for equipotential bonding are not supplied and need to be ordered separately.

Water connection

This washing machine has been supplied separately with a non-return valve (dual check valve). The non-return valve to prevent back siphoning must be fitted between the tap and water inlet hose or tap and Y-piece if connecting 2 hoses to the same tap. The non-return valve prevents water from the water inlet hose from flowing back into the on-site drinking water supply.

The flow pressure must amount to a minimum of 100 kPa and must not exceed 1000 kPa. If the flow pressure is higher than 1000 kPa, a pressure reducing valve must be used.

The machine must be connected to the water supply using the inlet hoses provided.

⚠ The connection points are subject to water supply pressure. Turn on the tap slowly and check for leaks. Correct the position of the seal and union if necessary.

Cold water connection

For the cold water connection, one tap each with a $\frac{3}{4}$ " external thread is required. A connector (Y-piece) can be used if required to connect 2 water inlet hoses with a $\frac{3}{4}$ " screw thread to a single tap with a 1" male thread.

The water inlet hose for cold water (blue stripes) is not intended to be used with a hot water connection.

Hot water connection

To minimise energy consumption during operation with hot water, the washing machine should be connected to a hot water ring circuit.

So-called "transmission pipes" (single pipes to hot water generators) can result in cooling down of the water remaining in the pipes if not in constant use. More energy would then be consumed to heat the suds up again.

Use the inlet hose supplied (red stripes) for the hot water connection.

The temperature of the water intake must not exceed 70 °C on appliances with electric heating (EL).

The appliance must be connected to the water supply using the water inlet hoses provided.

If there is no hot water supply at the installation location for the washing machine, the connection hose for hot water must be connected to the cold water supply. A Y-piece is required in this case. The cold water consumption increases accordingly to account for the missing hot water intake.

For functional and technical reasons, it is not possible to operate the machine exclusively with a hot water connection.

Even if a hot water connection is present, the washing machine must be connected to a cold water intake.

Drain valve

In the case of washing machines with a drain valve, a motorised valve is used to drain the machine. An HT DN 70 angle connector can be used for draining the machine directly into the waste water system (without a siphon) or into an on-site gully (with odour trap).

Thanks to an improved closing mechanism and a larger cross-section, even the coarsest of soiling does not leave any deposits or debris behind which could result in blockages. The dump valve can also be operated manually to allow the suds container to be emptied in the event of a power cut.

Installation notes

A vented drainage system is vital for unimpeded drainage. If several machines are connected to a single drain pipe, this should be sufficiently large to allow all machines to drain simultaneously.

The appropriate Miele installation set M.-No.: 05 238 090 is available from Miele for venting an HT DN 70 pipe (not available from Miele).

If the slope for drainage is extremely steep, the piping must be vented to prevent formation of a vacuum in the machine's drain system.

Slow or obstructed drainage or a backup of water in the drum as a result of undersized pipework can result in faults occurring during programmes, which will result in fault messages appearing in the display.

⚠ Outflowing suds can be as hot as 95 °C. Danger of burning!
Avoid direct contact.

Dispenser pump connections

Up to 12 dispenser pumps can be connected to the washing machine.

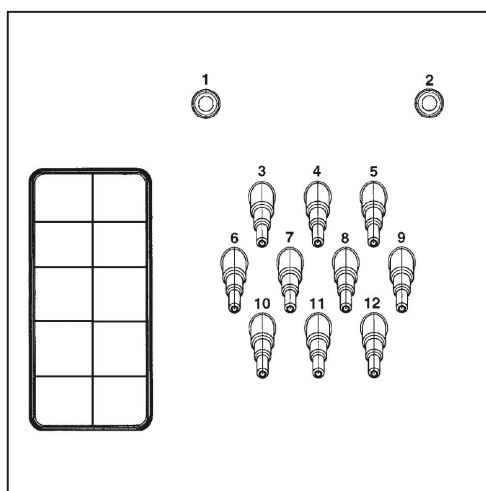

Dispenser pump connections on the back of the machine

Connections **1** and **2** are provided for viscous agents and can also be used for high pressure dispensing systems with water injection. The dispensing systems must comply with all relevant local and national regulations and be fitted with a suitable backflow prevention device. The maximum flow rate is 1500 ml/min with a maximum flow pressure of 300 kPa.

These connections are sealed and need to be drilled open using an 8 mm drill bit before connecting.

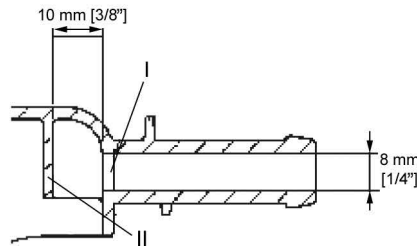

Make sure that you only drill through the first panel (I) as there is a deflecting panel (II) 10 mm behind it.

Connections **3** to **12** are provided for liquid detergent. High pressure dispensing systems with water injection must not be connected to these connections. The connectors are sealed and must be cut to the diameter of the hose with a small saw before they are connected.

If opened connections are no longer required, they must be resealed using a suitable sealant (e.g. silicone).

The connection, and also calibration, of external dispenser pumps is made via the Connector Box optional accessory.

A flowmeter or throughput sensors can be connected for precise monitoring of the dispensing quantity.

Connections for level monitoring are available for every agent dispensed.

Optional accessories

Only use genuine Miele spare parts and accessories with this machine.

Using spare parts or accessories from other manufacturers will invalidate the warranty, and Miele cannot accept liability.

Hard water kit (APWM062)

The hard water connection on the washing machine can be retrofitted with the optional hard water kit (APWM062).

The additional water connection allows hard water to be used and the programme duration will therefore be reduced. In addition, hard water is particularly suitable for the final rinse cycles.

APWM 019/020 - Connector Box

The Connector Box allows external hardware from Miele and other suppliers to be connected to the Miele Professional machine.

Peak load/Energy management

A peak load or energy management device can be connected via the Connector Box.

The peak load cut-out monitors the energy consumption of a system and deactivates individual pieces of equipment temporarily in order to ensure that certain total load limits are not exceeded. Monitoring is externally controlled.

Installation notes

When the peak-load function is activated, the heating is deactivated and the programme stopped. A message appears in the display to inform you of this.

The programme is resumed automatically when the peak-load function finishes.

Liquid dispensing connection

External liquid dispenser pumps with a level monitoring indicator or a flow meter can be used to dispense liquid detergents.

The dispenser pumps can only be programmed with MDU by a Miele approved technician.

It is particularly important to observe the manufacturer's instructions when using a combination of cleaning agents and special application products.

Payment system

This machine can be fitted with a single payment system (optional accessory) via the Connector Box.

The programming required for connecting a payment system can be carried out during the initial commissioning process. After initial commissioning, changes can only be made by Miele Professional Service.

WLAN/LAN interface

The washing machine is fitted with a WLAN/LAN interface for the purpose of data exchange.

The data interface provided at the LAN connection complies with SELV (Separated Extra Low Voltage) in accordance with IEC 62368-1. The LAN connection uses an RJ45 connector in accordance with EIA/TIA 568-B.

Connected appliances must also comply with SELV.

Plinth (APWM031/035)

The machine can be installed on a plinth (open or box plinth, available as an optional Miele accessory).

Elevating the washing machine gives a better ergonomic working position when loading or unloading. It also simplifies the installation of a waste water connection.

 The washing machine must be secured to the plinth immediately after installation. The plinth must be secured to the floor.

There is a risk of the washing machine falling off a raised plinth during a spin cycle if it is not secured.

Vapour and foam venting kit (APWM 063)

If excessive suds form, foam may escape from the vapour vent. To remove the foam, an optional vapour and foam venting kit can be used.

Installation

Standard

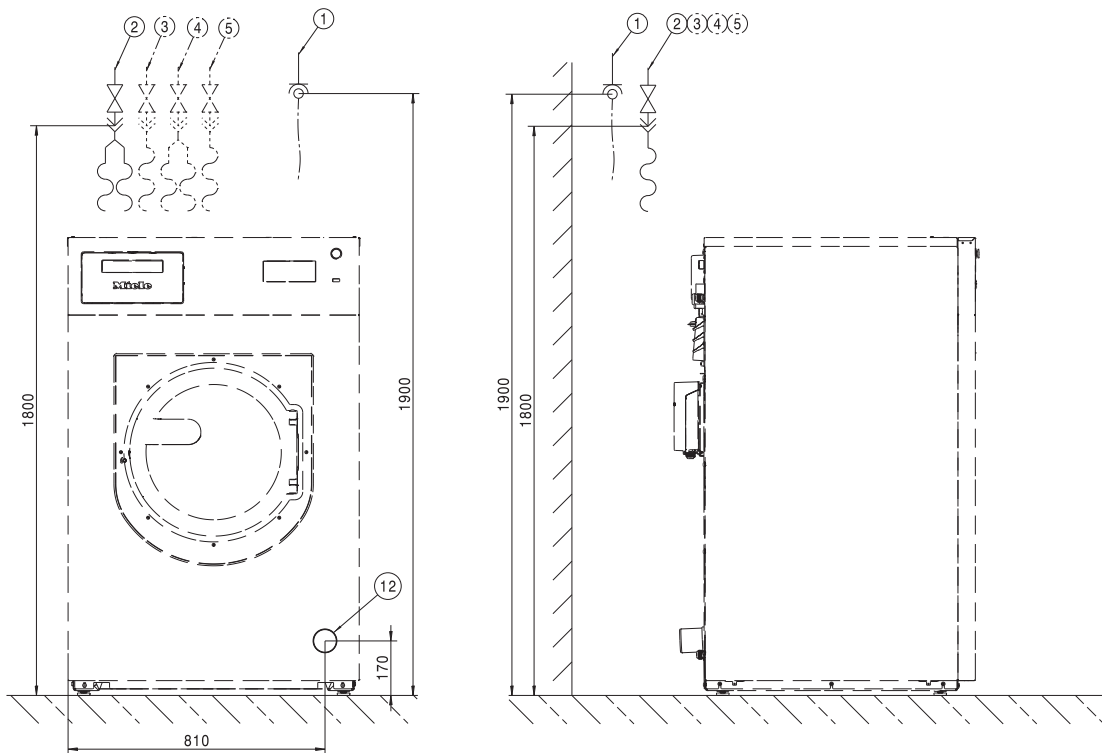

Dimensions in millimetres

- ① Electrical connection
- ② Cold water connection
- ④ Cold water connection for hard water (optional)
- ⑤ Cold water connection for liquid dispensing
- ⑫ Drain pipe

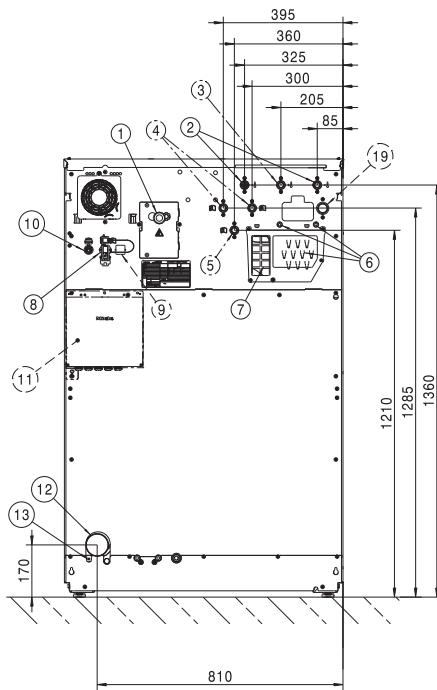

Dimensions in millimetres

- ① Electrical connection
- ② Cold water connection
- ④ Cold water connection for hard water (optional)
- ⑤ Cold water connection for liquid dispensing
- ⑥ Dispenser pump connections
- ⑦ Overflow and venting
- ⑧ Connector Box connection
- ⑨ Connector Kit connection (optional)
- ⑩ LAN connection
- ⑪ Connector Box (optional)
- ⑫ Drain pipe
- ⑬ Connection for equipotential bonding

Installation

Plinth

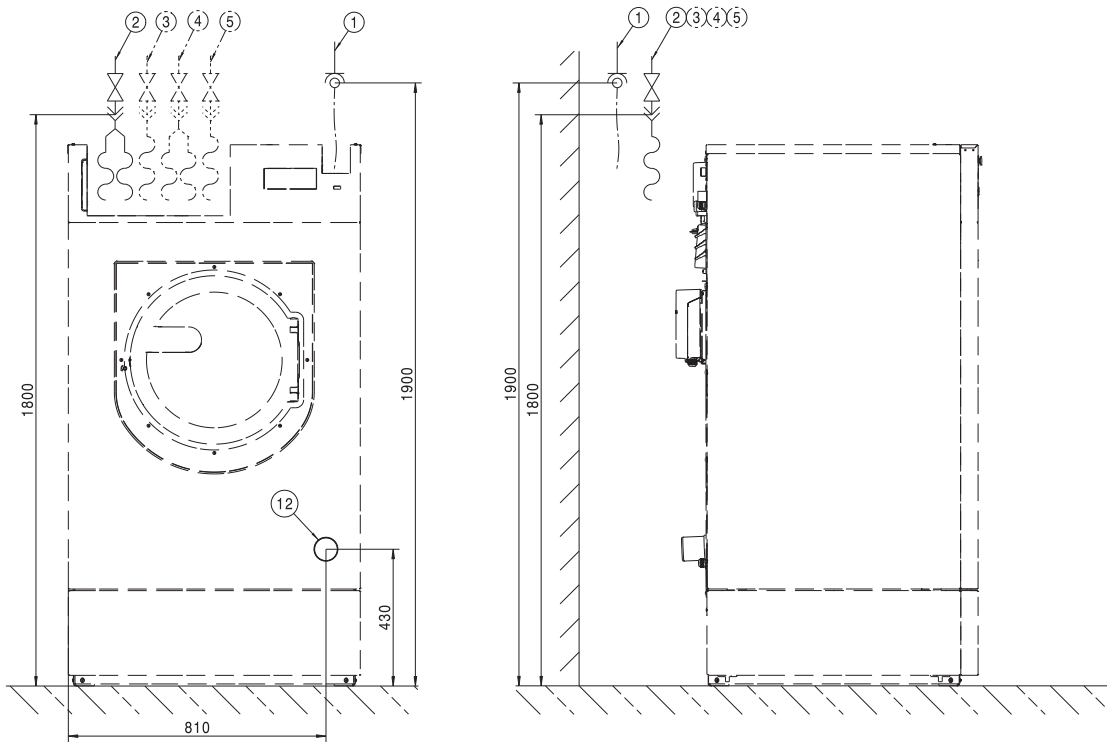

Dimensions in millimetres

- ① Electrical connection
- ② Cold water connection
- ④ Cold water connection for hard water (optional)
- ⑤ Cold water connection for liquid dispensing
- ⑫ Drain pipe

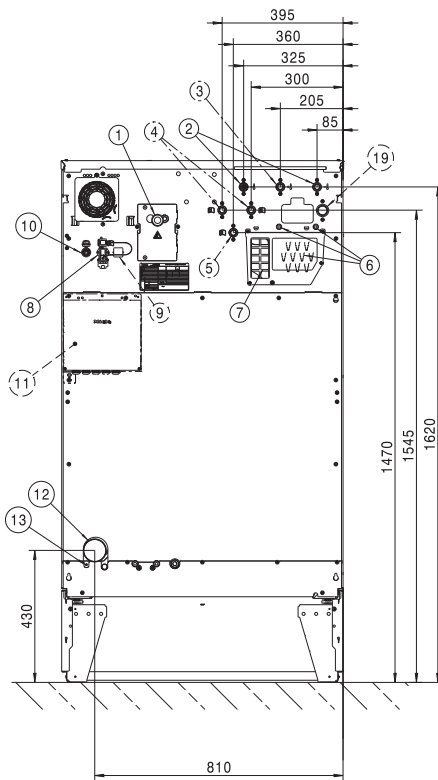

Dimensions in millimetres

- ① Electrical connection
- ② Cold water connection
- ④ Cold water connection for hard water (optional)
- ⑤ Cold water connection for liquid dispensing
- ⑥ Dispenser pump connections
- ⑦ Overflow and venting
- ⑧ Connector Box connection
- ⑨ Connector Kit connection (optional)
- ⑩ LAN connection
- ⑪ Connector Box (optional)
- ⑫ Drain pipe
- ⑬ Connection for equipotential bonding

Installation

Standard

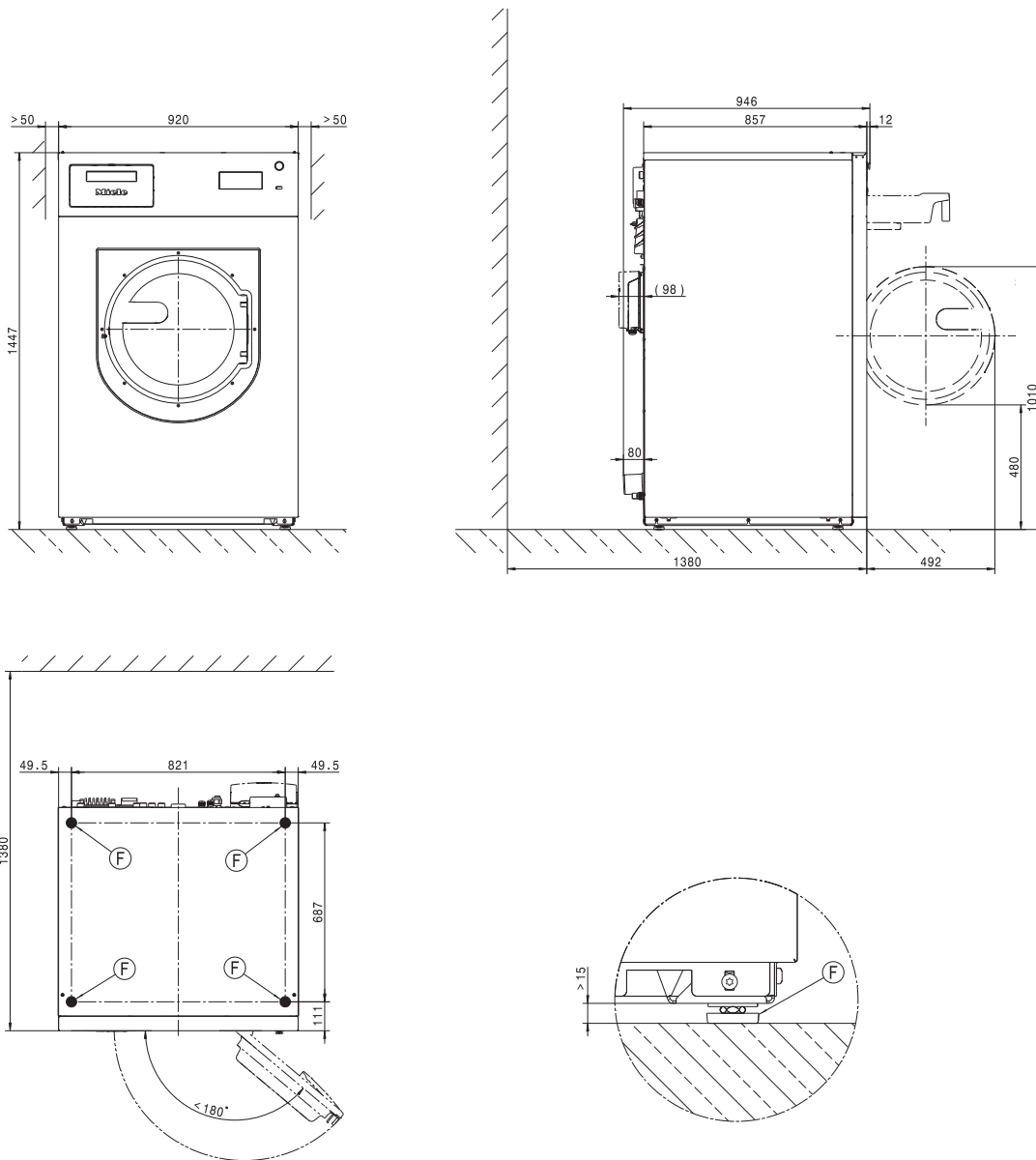

Dimensions in millimetres

ⓕ machine feet

Plinth

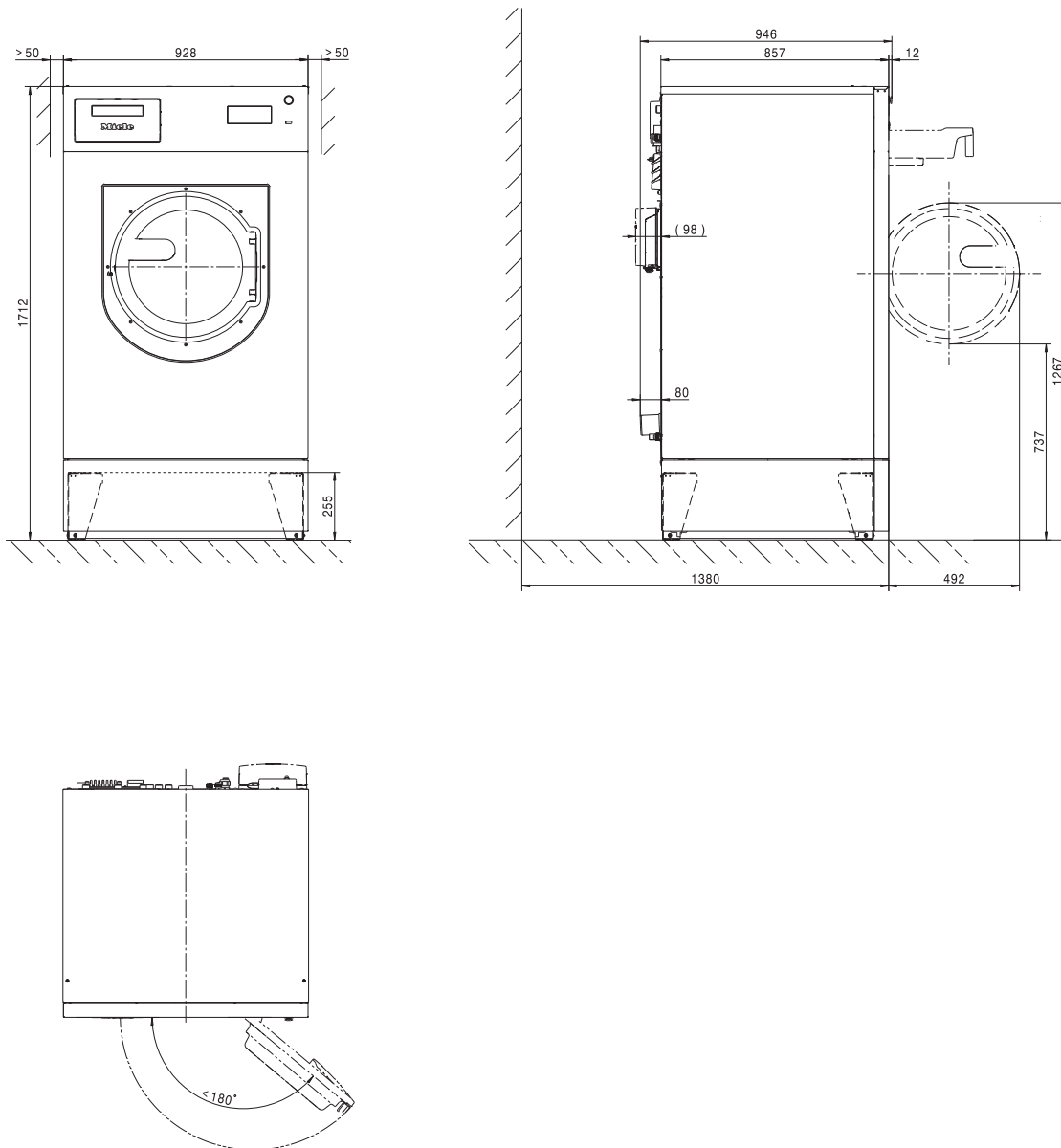

Dimensions in millimetres

Installation

Floor anchoring

Standard

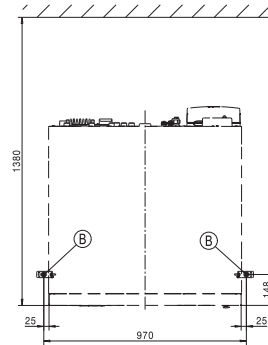
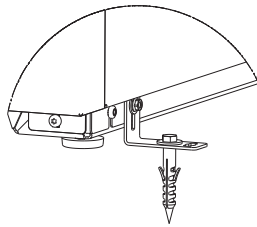
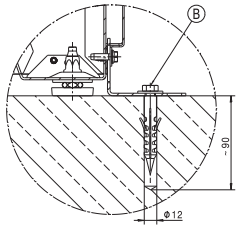

Multiple side-by-side installation

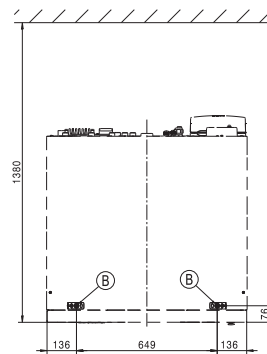
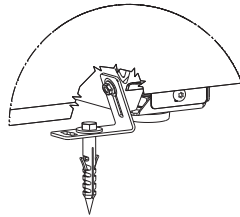
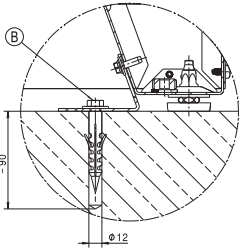

Marine applications

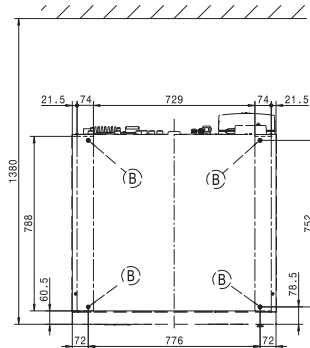
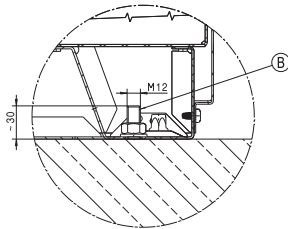

Plinth

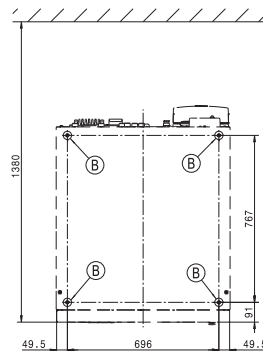
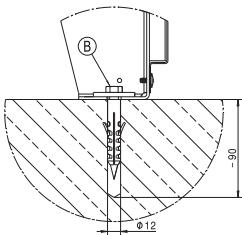

Dimensions in millimetres

Ⓟ screw / anchor point

Voltage versions and electrical data

3N AC 400 V EL

Supply voltage	3N AC 400 V
Frequency	50/60 Hz
Fuse rating (on site)	35 A
Total rated load	19 kW
Mains connection cable, min. cross-section	6 mm ²

Technical data

Water connection

Cold water connection

Required flow pressure	100 - 1000 kPa (1 - 10 bar)
Maximum flow rate	31.5 l/min
Threaded union required (male thread, to be provided by customer in accordance with AS 3688, flat sealing)	3 x 3/4"
Length of water inlet hose supplied	3 x 1550 mm

Hot water connection

Maximum permissible hot water temperature	70 °C
Required flow pressure	100 - 1000 kPa (1 - 10 bar)
Maximum flow rate	16 l/min
Threaded union required (male thread, in accordance with AS 3688, flat sealing)	1 x 3/4"
Length of water inlet hose supplied	1550 mm

Hard water connection (optional)

Required flow pressure	100 - 1000 kPa (1 - 10 bar)
Maximum flow rate	32 l/min
Threaded union required (male thread, in accordance with AS 3688, flat sealing)	2 x 3/4"
Length of water inlet hose supplied	2 x 1550 mm

Drainage

Maximum drain water temperature	95 °C
Waste water connection (on machine)	Plastic pipe HT DN 70
Drain (on-site)	Connection DN 70
Maximum drainage rate	200 l/min

Connection for equipotential bonding

Male thread	M10
Toothed washers	M10

Installation dimensions

Casing width (without add-on components)	920 mm
Casing height (without add-on components)	1447 mm
Casing depth (without add-on components)	857 mm
Overall machine width	924 mm
Overall machine height	1450 mm
Overall machine depth	946 mm
Minimum width of transport opening	1020 mm
Minimum distance between wall and front of appliance	1380 mm
Diameter of door opening	415 mm
Door opening angle	180°

Anchoring

Standard

Required anchor points	2
DIN 571 wood screw (diameter x length)	12 mm x 90 mm
Rawl plugs (diameter x length)	16 mm x 80 mm

With plinth (APWM UO/UG)

Required anchor points	4
DIN 571 wood screw (diameter x length)	12 mm x 90 mm
Rawl plugs (diameter x length)	16 mm x 80 mm

Concrete plinth

Required anchor points	2
DIN 571 wood screw (diameter x length)	12 mm x 90 mm
Rawl plugs (diameter x length)	16 mm x 80 mm

Transport data, weight and floor load

Models with detergent drawer (DD)

Packaging width	1210 mm
Packaging height	1585 mm
Packaging depth	1130 mm
Gross volume	2168 l
Gross weight*	409 kg
Net weight*	389 kg
Maximum floor load during operation*	5755 N

*depending on equipment configuration

Emissions data

Sound pressure level at workplace, washing	51 dB (A)
Sound power level, washing	60.0 dB (A)
Sound pressure level at workplace, spinning	65 dB (A)
Sound power level, spinning	77.0 dB (A)
Average heat dissipation rate to installation site	6.48 MJ/h

Miele Australia Pty. Ltd.

ACN 005 635 398

ABN 96 005 635 398

Melbourne:

Level 4, 141 Camberwell Road

Hawthorn East, VIC 3123

Telephone: 1300 731 411

service.prof@miele.com.au

**www.miele.com.au/professional
sales@miele-professional.com.au**

Miele New Zealand Limited

IRD 98 463 631

8 College Hill

Freemans Bay

Auckland 1011

New Zealand

Telephone: 0800 4 MIELE

(0800 464 353)

www.miele.com.au/professional

sales@miele-professional.com.au



Miele Global Headquarters: Miele & Cie. KG
Carl-Miele-Straße 29, 33332 Gütersloh, Germany