

## Operating and installation instructions Freezer













To avoid the risk of accidents or damage to the appliance it is **essential** to read these instructions before it is installed and used for the first time.

# Contents



---

<b>Warning and Safety instructions</b> .....	<b>5</b>
<b>Caring for the environment</b> .....	<b>14</b>
<b>Installation</b> .....	<b>15</b>
Location .....	15
Climate range .....	15
Installation notes .....	16
Adjoining cabinets/units .....	16
Load-bearing capacity of the niche floor .....	17
Ventilation .....	17
Door hinging .....	17
Side-by-side .....	18
Specifications for the mains water connection .....	19
Building-in dimensions .....	20
Dimensions with appliance door open (opening angle 115°) .....	22
Dimensions of the furniture front .....	23
Installing the appliance .....	24
Before starting .....	24
Tools required .....	24
Weight of the furniture front .....	25
Aligning the building-in niche .....	25
Checking the installation niche .....	26
Before installation .....	27
Preparing the building-in niche .....	28
Pushing the refrigeration appliance into the building-in niche .....	31
Aligning the refrigeration appliance .....	32
Securing the refrigeration appliance in the building-in niche .....	35
Preparing to install the furniture fronts .....	37
Securing and aligning the furniture front .....	40
Securing the covers .....	44
Securing the plinth ventilation grille and plinth panel .....	46
Aligning the Ice/Water dispenser .....	46
Mains water connection .....	51
Information about the mains water connection .....	51
Connecting the refrigeration appliance to the water supply .....	52
Electrical connection .....	53
<b>Saving energy</b> .....	<b>55</b>
<b>Guide to the appliance</b> .....	<b>57</b>
Main screen .....	58
Settings mode  .....	60
<b>Accessories</b> .....	<b>62</b>
Accessories supplied .....	62

Optional accessories .....	62
<b>Initial commissioning</b> .....	<b>63</b>
Before using for the first time .....	63
Choosing the right door assistant (Push2open/Pull2open) .....	63
Miele@home .....	63
Operating the refrigeration appliance .....	65
Performing initial commissioning .....	66
<b>Switching on and off</b> .....	<b>67</b>
Switching off for longer periods of time .....	68
<b>Selecting additional settings</b> .....	<b>69</b>
Switching Keypad lock  on or off .....	69
Switching Eco mode  on or off .....	69
Performing a Self test  .....	70
Switching on the Door assistant  .....	70
Switching off the Door assistant  .....	72
Miele@home .....	73
Switching off the Demo mode  .....	74
Resetting the settings to their default settings  .....	75
Selecting settings for lighting the Ice/Water dispenser  .....	77
Switching Sabbath mode  on or off .....	78
Switching on, switching off or resetting the Water filter display  .....	79
<b>The correct temperature</b> .....	<b>81</b>
Setting the temperature .....	81
Temperature range .....	82
<b>Using Super freeze</b> .....	<b>83</b>
<b>Temperature and door alarm</b> .....	<b>84</b>
<b>Adjusting the interior fittings</b> .....	<b>86</b>
Removing or moving the shelves .....	86
Removing the shelf above the ice maker .....	86
Removing the freezer baskets .....	87
<b>Freezing and storing food</b> .....	<b>88</b>
Maximum freezing capacity .....	88
Freezing fresh food .....	88
Storing frozen food .....	88
Home freezing .....	89
Placing food in the freezer .....	90
Storage time for frozen food .....	90
Defrosting frozen goods .....	91
Cooling drinks quickly .....	91

# Contents

---

<b>Operating the Ice/Water dispenser</b> .....	<b>92</b>
Switching the Dispenser unit  on .....	93
Dispensing chilled water .....	94
Dispensing ice cubes and crushed ice .....	94
Switching the Dispenser unit  off .....	95
Switching the system lock on/off .....	95
<b>Automatic defrosting</b> .....	<b>96</b>
<b>Cleaning and care</b> .....	<b>97</b>
Cleaning agents .....	97
Before cleaning the refrigeration appliance.....	98
Interior cabinet and accessories .....	99
Cleaning and emptying the ice cube container.....	99
Cleaning the drip tray.....	100
Cleaning the door seal.....	100
Cleaning the ventilation gaps .....	100
Cleaning the water filter (IntensiveClear mesh filter) .....	100
After cleaning.....	102
<b>Water filter</b> .....	<b>103</b>
Changing the IntensiveClear active charcoal filter (see “Optional accessories”) .....	104
<b>Problem solving guide</b> .....	<b>106</b>
<b>Noises</b> .....	<b>117</b>
<b>Service</b> .....	<b>118</b>
Contact in the event of a fault .....	118
EPREL database .....	118
Warranty .....	118
<b>EU Conformity declaration</b> .....	<b>119</b>
<b>UK Conformity declaration</b> .....	<b>120</b>
<b>Copyrights and Licences</b> .....	<b>121</b>

## Warning and Safety instructions

This refrigeration appliance complies with current safety requirements. Inappropriate use can, however, lead to personal injury and material damage.

Please read the operating and installation instructions carefully before using the refrigeration appliance for the first time. They contain important information on safety, installation, use and maintenance. This is to protect yourself from injury, and from damaging your refrigeration appliance.

In accordance with standard IEC 60335-1, Miele expressly and strongly advises that you read and follow all information provided on installing the refrigeration appliance, as well as the safety notes and warnings.

Miele cannot be held liable for injury or damage caused by non-compliance with these instructions.

Keep these operating and installation instructions in a safe place and pass them on to any future owner.

 Risk of injury and damage due to the refrigeration appliance tipping over.

This refrigeration appliance is very heavy and can tip forwards when the appliance door is open.

Keep the appliance door shut until the refrigeration appliance has been built in and secured in its installation niche in accordance with the operating and installation instructions.

### Correct application

- ▶ This refrigeration appliance is intended for use in the home and in similar environments, for example
  - in shops, offices and similar work settings
  - by the guests in hotels, motels, bed & breakfasts and other typical home settings.

This refrigeration appliance is not intended for outdoor use.

## Warning and Safety instructions

---

▶ This refrigeration appliance is intended exclusively for domestic use to store deep-frozen food, to freeze fresh food, to make ice and to dispense drinking water.

Any other usage is not permitted.

▶ This refrigeration appliance is not suitable for storing and keeping cool medicines, blood plasma, laboratory preparations or similar substances or products that are subject to the Medical Device Directive. Incorrect use of the refrigeration appliance for such purposes may cause deterioration of the items stored. The refrigeration appliance is also not suitable for use in areas where there is a risk of explosion.

Miele cannot be held liable for damage caused by improper or incorrect use or operation of the appliance.

▶ The appliance can only be used by people with reduced physical, sensory or mental capabilities, or lack of experience and knowledge, if they are supervised whilst using it, or have been shown how to use it in a safe way and recognise and understand the consequences of incorrect operation.

### Safety with children

▶ Children under 8 years of age must be kept away from the refrigeration appliance unless they are constantly supervised.

▶ Children 8 years and older may only use the appliance unsupervised if they have been shown how to use it in a safe way and recognise and understand the consequences of incorrect operation.

▶ Children must not be allowed to clean or maintain the appliance unsupervised.

▶ Please supervise children in the vicinity of the appliance and do not let them play with it.

▶ The appliance door hinges can cause injury. Keep children away at all times.

▶ Danger of suffocation! Whilst playing, children could become entangled in packaging (such as plastic wrapping) or pull it over their head and suffocate. Keep packaging material away from children.

### Technical safety

▶ The coolant circuit has been checked for leaks. The refrigeration appliance complies with statutory safety requirements and the appropriate EU directives.



▶ Warning: fire hazard/flammable materials. This symbol is on the compressor and indicates flammable materials. Do not remove this sticker.

The refrigerant inside the appliance (details on the data plate) is environmentally friendly but flammable.

The use of this refrigerant does, however, sometimes lead to a slight increase in the noise level of the appliance. In addition to the noise of the compressor, you might be able to hear the refrigerant flowing around the cooling circuit. Unfortunately, this cannot be avoided, but it does not affect the performance of the refrigeration appliance.

When transporting and installing the refrigeration appliance, ensure that no parts of the cooling circuit are damaged. Splashes of refrigerant can damage the eyes and leaking refrigerant can ignite.

In the event of damage:

- Avoid naked flames or anything which creates a spark.
- Disconnect the refrigeration appliance from the mains electricity supply.
- Ventilate the room where the refrigeration appliance is located for several minutes.
- Contact the Miele Customer Service Department.

▶ The more refrigerant there is in a refrigeration appliance, the larger the room it should be installed in. In the event of a leakage, if the appliance is in a small room, there is the danger of a combustible gas/air mixture building up. For every 8 g of refrigerant at least 1 m<sup>3</sup> of room space is required. The amount of refrigerant in the refrigeration appliance is stated on the data plate inside the appliance.

▶ To avoid the risk of damage to the appliance, make sure that the connection data (fuse rating, frequency and voltage) on the data plate corresponds to the household supply.

Check that this is the case before connecting the appliance. Consult a qualified electrician if in any doubt.

▶ The electrical safety of this appliance can only be guaranteed when correctly earthed. It is essential that this standard safety requirement is met. If in any doubt please have the electrical installation tested by a qualified electrician.

## Warning and Safety instructions

---

▶ Temporary or permanent operation on an autonomous power supply system or a power supply system that is not synchronised with the mains power supply (e.g. island networks, back-up systems) is possible. A prerequisite for operation is that the power supply system complies with the specifications of EN 50160 or an equivalent standard.

The function and operation of the protective measures provided in the domestic electrical installation and in this Miele product must also be maintained in isolated operation or in operation that is not synchronised with the mains power supply, or these measures must be replaced by equivalent measures in the installation. As described, for example, in the current version of BS OHSAS 18001–2 ISO 45001.

- ▶ The socket must not be concealed behind the refrigeration appliance and must be easily accessible so that the appliance can be quickly disconnected from the electrical supply in case of an emergency.
- ▶ If the electrical connection cable supplied is damaged, it must only be replaced by an original spare part to prevent a hazard for the user. Miele can only guarantee the safety of the appliance when original Miele spare parts are used. For safety reasons, such replacement may only be carried out by a qualified specialist or the Miele Customer Service Department.
- ▶ Do not connect the appliance to the mains electrical supply by a multi-socket adapter or extension lead. These are a fire hazard and do not guarantee the required safety of the appliance.
- ▶ If moisture gets into electrical components or into the mains connection cable, it could cause a short circuit. Therefore, do not operate this refrigeration appliance in areas which are exposed to moisture (e.g. in a garage or utility room).
- ▶ This appliance must not be used in a non-stationary location (e.g. on a ship).
- ▶ Do not use a damaged appliance. It could be dangerous. Check the appliance for visible signs of damage.
- ▶ For safety reasons, this appliance may only be used after it has been built in.



## Warning and Safety instructions

---

▶ The appliance must be disconnected from the power supply during installation, maintenance and repair work, and during installation work on the mains water connection. It is only completely isolated from the power supply when:

- the mains fuses are switched off, or
- the screw-out fuse is removed (where applicable), or
- the mains cable has been unplugged. Pull on the plug and not the cable when disconnecting it from the power supply.

▶ Unauthorised installation, maintenance and repairs, or a faulty mains water connection can cause considerable danger for the user. Installation, maintenance and repairs, installation work on the mains water connection, and all repairs on the ice/water outlet should only ever be carried out by a Miele-authorised technician.

▶ While the appliance is under warranty, repairs should only be undertaken by a Miele authorised service technician. Otherwise the warranty is invalidated.

▶ Faulty components must only be replaced with genuine Miele original spare parts. Miele can only guarantee the safety standards of the appliance when Miele replacement parts are used.

▶ This refrigeration appliance is supplied with a special lamp to cope with particular conditions (e.g. temperature, moisture, chemical resistance, abrasion resistance and vibration). This lamp must only be used for the purpose for which it is intended. The lamp is not suitable for room lighting. Replacement lamps may only be fitted by a Miele authorised technician or by the Miele Customer Service Department. This refrigeration appliance contains several light sources with at least energy efficiency class F.

▶ Miele cannot be held liable for damage caused by a faulty mains water connection.

▶ The ice-cube maker must only be connected to a cold water supply.

▶ Risk of injury. Ensure that you do not come into contact with moving parts on dispensing mechanism of the ice cube maker or the heating element on the ice cube maker.

▶ In areas which may be subject to infestation by cockroaches or other vermin, pay particular attention to keeping the appliance and its surroundings clean at all times. Any damage caused by cockroaches or other vermin will not be covered by the warranty.

# Warning and Safety instructions

---

## Correct use

- ▶ This refrigeration appliance is designed for use within specific ambient temperatures (climate range). Do not use in ambient temperatures for which it is not designed. The climate range is stated on the data plate in the interior cabinet of the refrigeration appliance. A lower ambient temperature will cause the compressor to switch off for longer periods, meaning that the refrigeration appliance is unable to maintain the required temperature.
- ▶ Do not cover or block the air vents as this could impair the efficiency of the appliance, increase the electricity consumption and could cause damage to the components.
- ▶ If storing food which contains a lot of fat or oil in the appliance or the door, make sure that it does not come into contact with plastic components as this could cause stress cracks or break the plastic.
- ▶ Risk of fire and explosion. Do not store explosive materials in the refrigeration appliance or any products containing propellants (e.g. spray cans). Electrical components can cause flammable mixes of gases to ignite.
- ▶ Danger of explosion. Do not operate any electrical equipment (e.g. an electric ice-cream maker) inside the refrigeration appliance.  
Danger of sparking and explosion.
- ▶ Danger of injury and damage to the appliance. Do not store cans or bottles containing carbonated drinks or liquids which could freeze in the freezer zone. Otherwise they could burst.
- ▶ Danger of injury and damage to the appliance. When cooling drinks quickly in the freezer zone, make sure bottles are not left in for more than one hour. Otherwise they could burst.
- ▶ Danger of injury. Never handle frozen food or the metal parts of the appliance with wet hands. Your hands may freeze to the frozen food or to the metal.
- ▶ Danger of injury. Do not take ice cubes out with your bare hands and never place ice cubes or ice lollies in your mouth straight from the freezer zone. The very low temperature of the frozen food can cause frost burn to the lips and tongue.
- ▶ Do not refreeze partially or fully defrosted food. Consume defrosted food as soon as possible, as it will lose its nutritional value and spoil if left for too long. Defrosted food may only be re-frozen after it has been cooked.

# Warning and Safety instructions

---

▶ Observe the manufacturer's "use-by" dates and storage instructions given on food to avoid the risk of food poisoning. Storage times will depend on several factors, including the freshness and quality of the food, as well as the temperature at which it is stored.

## Accessories and spare parts

- ▶ Only use original Miele accessories. If other parts are used, warranty, performance and product liability claims will be invalidated.
- ▶ Miele will guarantee to supply functional spare parts for a minimum of 10 years and up to 15 years following the discontinuation of your refrigeration appliance.

## Cleaning and care

- ▶ Do not use any oils or grease on the door seals, as these will cause the seals to deteriorate and become porous with time.
- ▶ Do not use a steam cleaning appliance to clean or defrost this appliance.  
Steam could reach electrical components and cause a short circuit.
- ▶ **WARNING! DANGER of injury and damage!** Do not use any mechanical or other types of aids which are not recommended by the manufacturer to accelerate the defrosting process.
- ▶ Sharp edged or pointed objects will damage the evaporator, causing irreversible damage to the appliance. Do not use sharp edged or pointed objects to
  - remove frost and ice,
  - separate frozen food or remove ice trays.
- ▶ Do not place electric heaters or candles in the appliance to defrost it. These can damage the plastic parts.
- ▶ Do not use defrosting sprays or de-icers, as they could contain substances which could damage the plastic parts or which might cause the build-up of gases and pose a danger to health.

## Transport

- ▶ Always transport the appliance in an upright position and in its original transport packaging to avoid damage in transit.
- ▶ Danger of injury and damage to the appliance. The refrigeration appliance is very heavy and must be transported by two people.

# Warning and Safety instructions

---

## Disposal of your old appliance

▶ Children playing could become trapped in the appliance and could suffocate.

- Remove the appliance doors.
- Remove the drawers.
- Leave the adjustable shelves in the refrigeration appliance so children cannot climb inside.
- If your old refrigeration appliance has a door lock, destroy it. This will prevent the risk of children playing accidentally locking themselves in and endangering their lives.

▶ Risk of electric shock!

- Cut the plug off the mains connection cable.
- Cut the mains connection cable off the old appliance.

▶ Dispose of the plug and mains connection cable separately from the old appliance.

▶ During and after disposal, make sure that the refrigeration appliance is not placed near petrol or other flammable gases and liquids.

▶ Risk of fire due to escaping oil or refrigerant!

The refrigerant and oil inside the appliance are flammable. In high enough concentrations, escaping refrigerant or oil may ignite if they come into contact with an external heat source.

During disposal, make sure that the cooling circuit is not damaged in order to prevent refrigerant and oil escaping in an uncontrolled manner (see the data plate for details of the refrigerant).

▶ Splashes of coolant can damage the eyes. Be careful not to damage any part of the pipework whilst awaiting disposal, e.g. by

- puncturing the coolant channels in the condenser,
- bending any pipework, or
- scratching the surface coating.

## Symbol on the compressor (depending on model)

This information is only relevant for recycling. There is no risk during normal operation.
--

## Warning and Safety instructions

---



- ▶ The oil in the compressor can be fatal if swallowed or if it penetrates the airways.

# Caring for the environment

---

## Disposing of the packaging material

The packaging material is used for handling and protects the appliance from transport damage. The packaging material used is selected from materials which are environmentally friendly for disposal and can generally be recycled.

Recycling the packaging material reduces the use of raw materials. Use material-specific collection points for valuable materials and take advantage of return options. Your Miele dealer will take the packaging material away.

## Disposing of your old appliance

Electrical and electronic appliances contain many valuable materials. They also contain certain materials, compounds and components which were essential for their correct functioning and safety. These could be hazardous to human health and to the environment if disposed of with household waste or if handled incorrectly. Please do not, therefore, dispose of your old appliance with household waste.



Take care not to damage your refrigeration appliance before or during disposal in an authorised, environmentally friendly manner. This is to ensure that refrigerant in the cooling circuit and oil in the compressor is contained, and will not leak into the environment.

Instead, please make use of officially designated collection and disposal points to dispose of and recycle electrical and electronic appliances in your local community, with your dealer or with Miele, free of charge. By law, you are solely responsible for deleting any personal data from the old appliance prior to disposal. You are legally obliged to remove any old batteries which are not securely enclosed by the appliance and to remove any lamps without destroying them, where this is possible. These must be taken to a suitable collection point where they can be handed in free of charge. Please ensure that your old appliance poses no risk to children while being stored for disposal.

## Location

This appliance should be installed in a dry, well-ventilated room.

When deciding where to install your refrigeration appliance, please bear in mind that it will use more energy if installed near to a heater, a cooker or other appliance that gives off heat.

Direct sunlight should also be avoided. The higher the room temperature, the longer the compressor runs and the higher the energy consumption of the refrigeration appliance is.

When installing the refrigeration appliance, please note the following:

- The socket must be easily accessible in an emergency, not concealed behind the appliance.
- The plug and power cable must not touch the rear of the refrigeration appliance as they could be damaged by vibrations from the appliance.
- Do not plug in other appliances behind the refrigeration appliance.

If installation near a heat source is unavoidable, observe the following minimum distances between the appliance and the heat source:

- At least 3 cm to electric or gas stoves
- At least 30 cm to oil or coal-based stoves

If it is not possible to observe these minimum distances, an isolation plate must be installed between the refrigeration appliance and the heat source.

## Climate range

This refrigeration appliance is designed for use within specific ambient temperatures (climate range). Do not use in ambient temperatures for which it is not designed. The climate range is stated on the data plate in the interior cabinet of the refrigeration appliance.

Climate range	Ambient temperature
SN	10 to 32 °C
N	16 to 32 °C
ST	16 to 38 °C
T	16 to 43 °C
SN-ST	10 to 38 °C
SN-T	10 to 43 °C

A lower ambient temperature leads to the compressor switching off for longer periods. This can cause the internal temperature in the refrigeration appliance to rise with the risk of food deteriorating and going off.

# Installation

---



Risk of damage due to high humidity.

In environments with high humidity, condensation can build up on external refrigeration appliance panels, which can cause corrosion.

Install the refrigeration appliance in a dry and/or air-conditioned room with sufficient ventilation.

After installation, make sure that the appliance door closes properly, the ventilation gaps are not covered and that the refrigeration appliance has been installed in accordance with the operating and installation instructions.

## Installation notes



Risk of damage and injury due to the refrigeration appliance tipping over.

This refrigeration appliance is very heavy and can tip forwards when the appliance door(s) is (are) open.

Keep the appliance door(s) shut until the refrigeration appliance has been built in and secured in its housing in accordance with these operating and installation instructions.

Due to its weight and size, the refrigeration appliance must be installed by two people.

## Adjoining cabinets/units

The appliance is screwed to the adjoining cabinets/units to the side and above. For this reason, it is essential that all cabinets/units are fixed to the ground or wall.



## Load-bearing capacity of the niche floor

To ensure the safe installation of the refrigeration appliance and to guarantee its correct functioning, the floor of the niche where the appliance is to be installed must be smooth and even.

It must be made from strong, rigid material.

Because the refrigeration appliance is extremely heavy when fully loaded, it is essential that the floor it stands on is able to bear its weight. If necessary, seek the advice of an architect or construction expert.

When fully loaded, the weight of the refrigeration appliance is approx.:

F 2462 Vi, F 2472 Vi	287 kg
F 2662 Vi, F 2672 Vi	348 kg

## Ventilation

 Risk of fire and damage due to insufficient ventilation.

If the refrigeration appliance is not ventilated sufficiently, the compressor will run more frequently and for longer periods.

This will result in increased energy consumption and a higher operating temperature for the compressor. This may, in turn, cause damage to the compressor.

Please ensure that there is adequate ventilation around the refrigeration appliance.

It is essential to observe the required ventilation gaps. The ventilation gaps must not be covered or blocked in any way.

## Door hinging

The refrigeration appliance is supplied with a fixed door hinge. The door hinge cannot be changed.

# Installation

## Side-by-side

This appliance can be installed side-by-side with another refrigeration appliance. The following overview will show you which side-by-side installation options you have with your refrigeration appliance.

Depending on the installation situation, you will need the side-by-side installation kit for side-by-side installation (see “Accessories – Optional accessories”).

Instructions for installing refrigeration appliances side-by-side can be found in the side-by-side installation kit installation instructions.

### ... with partition wall

The wall **a** between the side-by-side refrigeration appliances must be **at least 16 mm** thick.

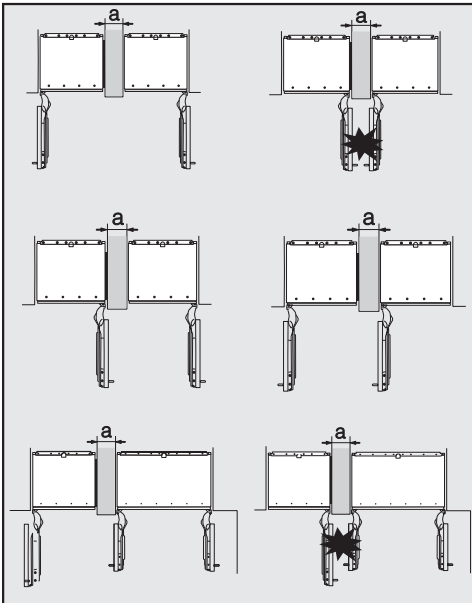

If the door hinges of the refrigeration appliances are next to each other, you must take into account the thickness of the furniture fronts and door handles so that the appliance doors do not collide and become damaged if they are opened at the same time.

The refrigeration appliances are secured individually in their installation niche using the supplied installation material.

If the partition wall **a** is **narrower than 160 mm**, you will need the side panel heater from the side-by-side installation kit to prevent condensation from forming and any resulting damage.

When planning installation niches, please note that the niche into which the refrigeration appliance with the side panel heater is installed must be **4 mm** wider (see “Installation – Building-in dimensions”).

If the partition wall **a** is **thicker than 160 mm**, you do not need the side-by-side installation kit, nor the side panel heater.

## ... without partition wall

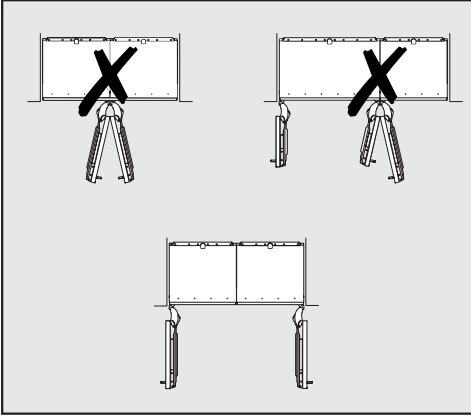

If the refrigeration appliances are to be installed next to each other without a partition wall between them, they will need to be joined together with the side-by-side installation kit. In addition, you must install the side panel heater to prevent condensation from forming and any resulting damage.

## Specifications for the mains water connection

- Connection to the water supply must comply with the applicable regulations in the country where the appliance is being installed.  
All appliances and systems used to supply water to the refrigeration appliance must also comply with the applicable regulations in the respective country.
- The appliance may only be connected to the mains water supply by suitably qualified persons.
- The quality of the incoming water must conform to the requirements for drinking water in the country where the refrigeration appliance is being used.
- Connect the stainless steel hose of the refrigeration appliance to the fresh water supply and do not connect to a water supply in which the water might stagnate.
- The refrigeration appliance is only suitable for connection to a cold water line.
- The water pressure must be between 200 kPa and 800 kPa (2 and 8 bar).
- A stopcock must be provided between the stainless steel hose and the mains water supply to ensure that the water supply can be cut off if necessary.
- Make sure that the stopcock is still accessible after the refrigeration appliance has been installed.

# Installation

---

## Building-in dimensions

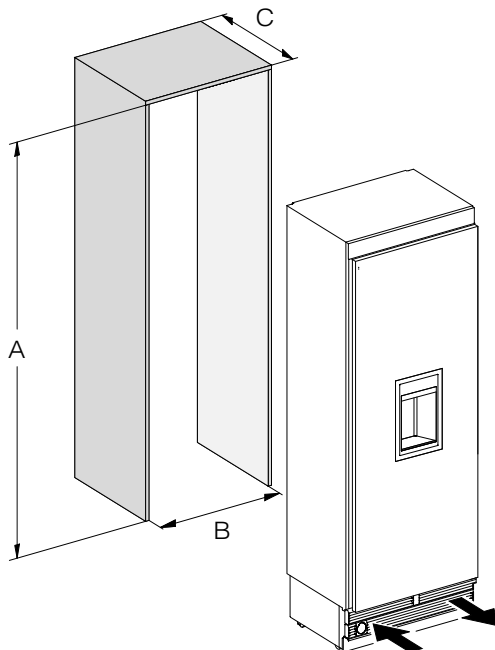

	A	B	C
F 2462 Vi, F 2472 Vi	2134–2164 mm	458 mm	610 mm + furniture front (19–38 mm)
F 2662 Vi, F 2672 Vi	2134–2164 mm	610 mm	610 mm + furniture front (19–38 mm)

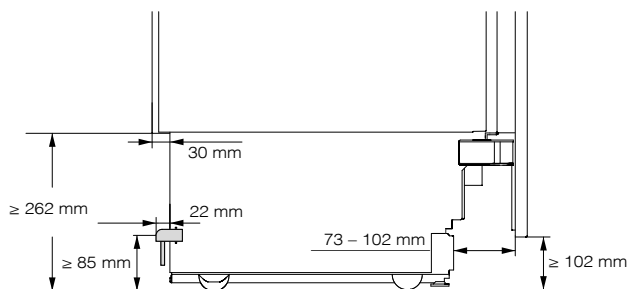

Side view

# Installation

## Dimensions with appliance door open (opening angle 115°)

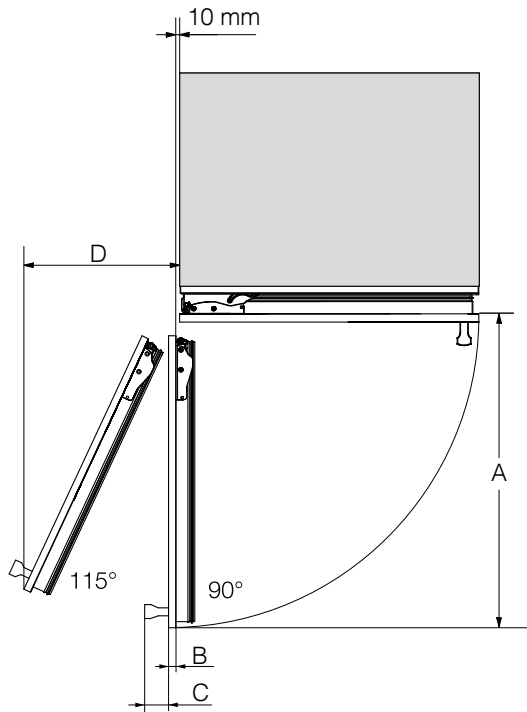

	A	B*	C*	D (with a furniture front of 19 mm)
F 2462 Vi, F 2472 Vi	525 mm	Furniture front (19–38 mm)	Door handle	237 mm
F 2662 Vi, F 2672 Vi	677 mm	Furniture front (19–38 mm)	Door handle	296 mm

\* The dimensions of the furniture front and the door handle vary depending on the design of the kitchen.

The opening angle of the appliance door must not be limited to 90° because otherwise the freezer baskets and ice cube container cannot be removed.

## Dimensions of the furniture front

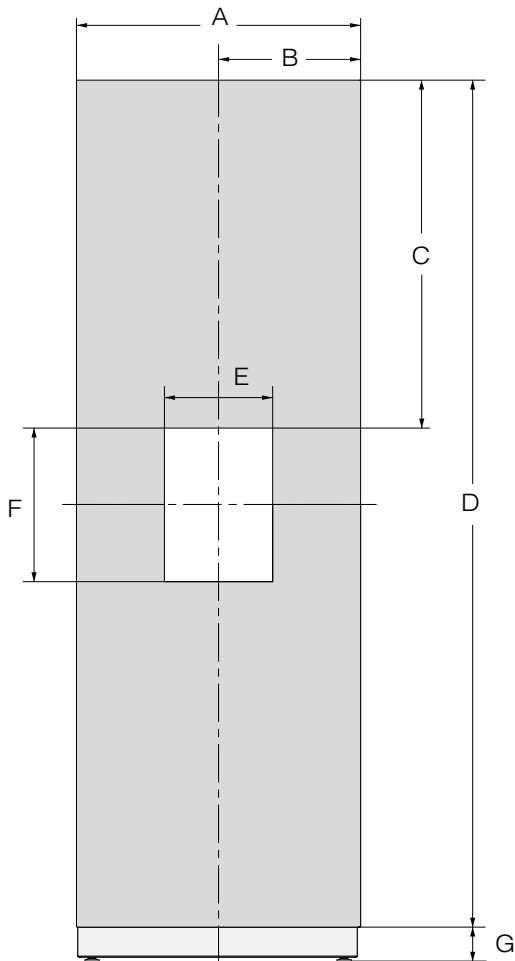

	A	B	C	D	E	F	G
F 24x2 Vi	451 m m	225.5 mm	830.5 mm	2029 mm	230 m m	368 m m	≥ 102–132 mm
F 26x2 Vi	604 m m	302 m m	830.5 mm	2029 mm	230 m m	368 m m	≥ 102–132 mm

# Installation

---

## Installing the appliance

### Before starting ...

It is essential to read these operating and installation instructions carefully before starting to install the refrigeration appliance.

The refrigeration appliance should be installed by a suitably qualified installer in accordance with these operating and installation instructions. Safe operation of the refrigeration appliance is only assured if it has been installed and connected in accordance with these operating and installation instructions.

 Risk of damage and injury due to the refrigeration appliance tipping over.

This refrigeration appliance is very heavy and can tip forwards when the appliance door is open.

Keep the appliance door shut until the refrigeration appliance has been built in and secured in its niche in accordance with these operating and installation instructions.

Due to its weight and size, the refrigeration appliance **must be installed by two people.**

### Tools required

- Cordless drill
- TX 20 screwdriver
- Hammer drill
- Drill bits in various sizes, depending on materials
- Hammer
- Open spanner
- Ratchet wrench, attachment: socket, 8 mm
- Adhesive tape
- Utility knife
- Pipe wrench
- Spirit level
- Tape measure
- Pencil

### Other

- Step ladder
- Sack truck



## Weight of the furniture front

Before fitting a furniture front, ensure that the weight of the furniture front does not exceed the maximum permitted weight:

Refrigeration appliance	Max. weight of the furniture front
F 2462 Vi, F 2472 Vi	71 kg
F 2662 Vi, F 2672 Vi	68 kg

 If the furniture front is too heavy, this can cause damage.

Fitting a furniture front which is heavier than the maximum permitted weight could damage the hinges. This damage can affect various factors, such as operation of the appliance.

Before fitting a furniture front, ensure that the weight of the furniture front does not exceed the maximum permitted weight.

## Aligning the building-in niche

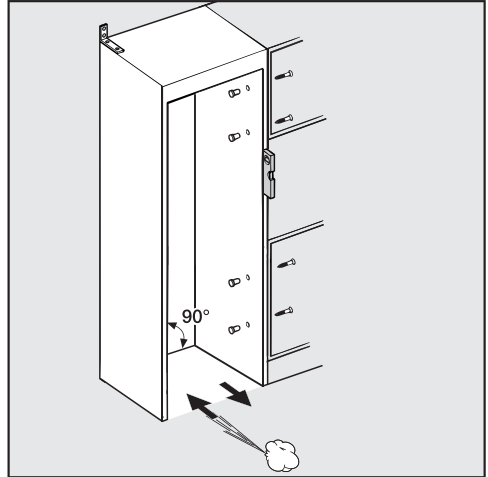

The building-in niche must be carefully aligned using a spirit level before the refrigeration appliance is installed. The niche corners must be at 90° angles to each other, otherwise the furniture front will not sit straight on all 4 corners of the building-in niche.

# Installation

---

## Checking the installation niche

- Check the installation dimensions (see “Installation – Installation dimensions”).
- Check the position of the electrical connection. The length of the electrical connection cable is 3 m.

The electrical socket must not be concealed behind the appliance and must be easily accessible in an emergency.

- Check the position of the fresh water connection. The available length of the stainless steel hose is approx. 2 m.

The stopcock must not be concealed behind the appliance and must be easily accessible in an emergency.

- Check the surroundings for possible collisions (see “Installation – Dimensions with appliance door open”).
- Only install the refrigeration appliance in stable, solid installation niches, positioned on an even and level floor.
- Also check the installation niche for the following criteria:
  - The side walls of the installation niche must be even.
  - The surrounding walls of the installation niche must be at least 16 mm thick.
  - The surrounding walls must be securely fixed to the floor or wall.
  - Shortened side walls must be at least 100 mm deep.

## Before installation

- Before installation, remove any accessories from the back of the appliance.

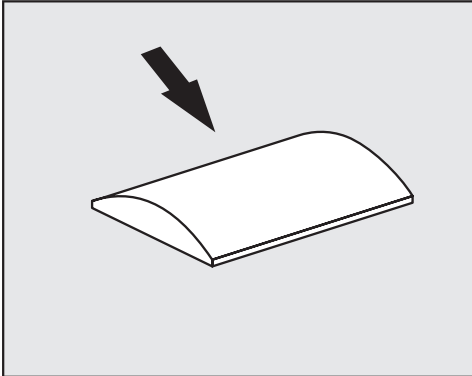

 Risk of damage due to insufficient ventilation.

If the refrigeration appliance is not sufficiently ventilated, this may cause mould to form and, in the long term, lead to damage to the outside of the refrigeration appliance and in the installation niche.

Do not remove the spacers from the outside of the appliance under any circumstances.

Do not compress the spacers under any circumstances.

The spacers guarantee the necessary distance between the refrigeration appliance and the installation niche.

- Check the refrigeration appliance for transport damage.

Do not install a damaged refrigeration appliance.

- Check that all parts at the back of the appliance are unhindered.

- To protect the floor during installation, secure an off-cut of flooring or similar material to the floor in front of the installation area.

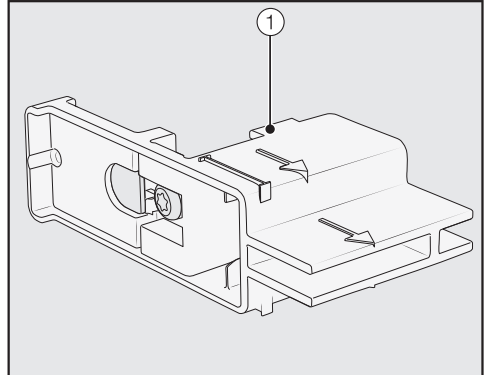

- Do **not** remove the installation aids ① from the appliance door. These will be required later for aligning the appliance in the building-in niche.

 Risk of damage and danger of injury due to the refrigeration appliance tipping over.

As soon as you unscrew the brackets that fix the refrigeration appliance to the pallet, the appliance is no longer secured.

Due to its weight and size, the refrigeration appliance **must be installed by two people**.

# Installation

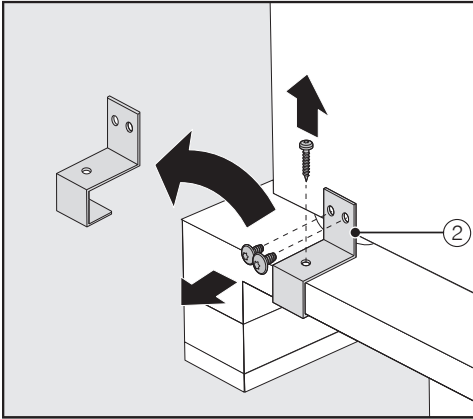

- Unscrew the fixing brackets ②.
- With the help of several people as required, carefully lift the refrigeration appliance from the pallet, starting with the back of the appliance.

**⚠** Risk of damaging the floor from the load.

Moving the refrigeration appliance can cause damage to the floor. Move the refrigeration appliance carefully on floors that are sensitive to scratching.

As soon as you have set the appliance upright, you can move it using the rollers on the bottom.

## Preparing the building-in niche

**⚠** Risk of damage and injury due to the refrigeration appliance tipping over.

This refrigeration appliance is very heavy and can tip forwards when the appliance doors are open.

The building-in niche must be secured to the wall behind it and/or above it with several screws. Only this will prevent the refrigeration appliance from tipping over after being installed.

In addition, use the provided anti-tip brackets to secure the building-in niche.

The parts required for installation are supplied with the refrigeration appliance. The plastic bags supplied are marked with letters for easy identification.

- When performing the individual assembly steps, observe the letters specified and use the matching plastic bag with the required installation equipment.

The anti-tip brackets prevent the refrigeration appliance from tipping.

The anti-tip brackets are also used to fix the building-in niche securely to the surrounding walls.

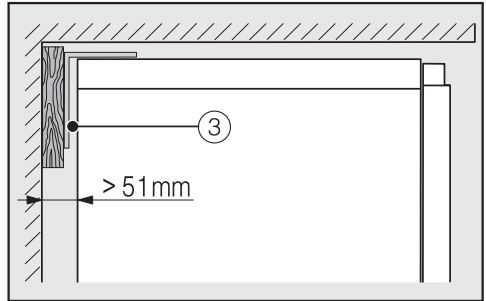
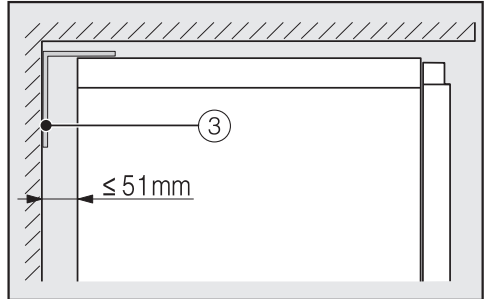
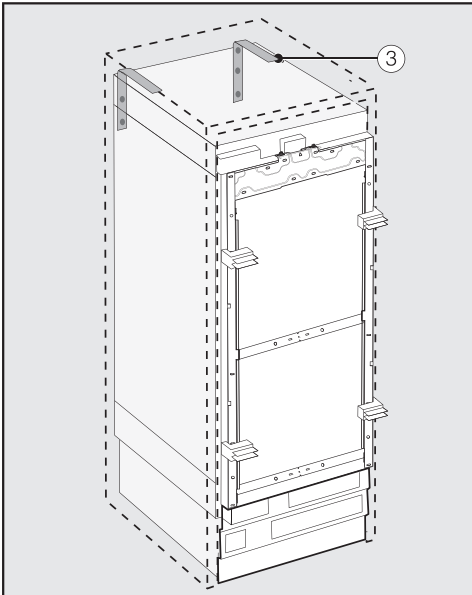

- Use 2 anti-tip brackets ③ for each individual refrigeration appliance or 4 anti-tip brackets for each (side-by-side) combination of 2 appliances.
- Position the anti-tip brackets ③ on the left and right of the building-in niche.
- Make sure that the gap between the refrigeration appliance's rear wall and the building-in niche does not exceed 51 mm.
- Place a wooden wedge behind the anti-tip brackets ③ if necessary.
- While holding the anti-tip brackets in place, mark the necessary drill holes on the rear wall of the building-in niche.

Depending on the subsequent adjustment of the feet, the anti-tip brackets are positioned 2134–2164 mm from the floor of the niche.

Risk of injury and damage due to tipping refrigeration appliance. If the anti-tip brackets are fixed too high up, they cannot be used to secure the refrigeration appliance. The distance between the anti-tip brackets and the refrigeration appliance must not exceed 8 mm.

# Installation

**B**

The accessory pack supplied contains fixing screws for various applications/materials.

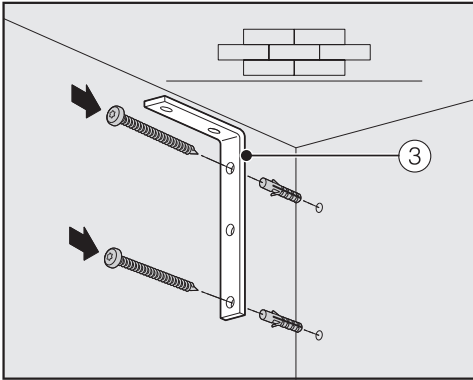

Securing to a concrete wall

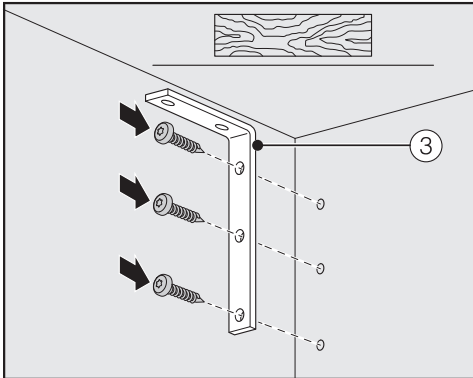

Securing to a wooden wall

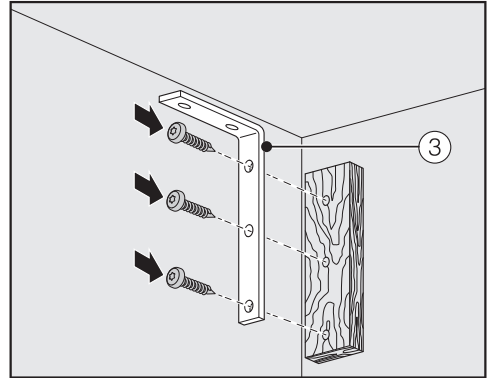

Securing with a wooden wedge

- Secure the building-in niche to the wall behind it and/or above it as required using the anti-tip brackets (3).
- Connect the refrigeration appliance to the mains water supply (see “Installation – Mains water connection”).

## Pushing the refrigeration appliance into the building-in niche

Push the refrigeration appliance into the niche, taking care not to damage the electrical and mains water connections.

If you are installing several refrigeration appliances side by side, now secure the appliances to one another (see the installation instructions for the side-by-side installation kit).

- To ensure that the refrigeration appliance can then be aligned correctly, the plinth ventilation grille must be removed from the appliance plinth:

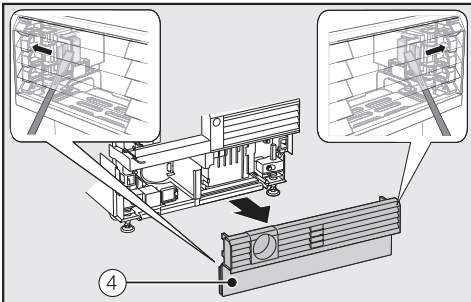

- Carefully guide a flat-head screwdriver through the plinth ventilation grille ④ on both sides and use it to push the internal plastic latches outwards to release the plinth ventilation grille.
- Place the plinth ventilation grille to one side.

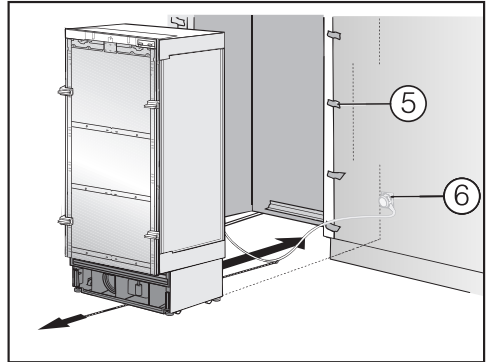

- Affix edge protection ⑤ to the adjacent furniture fronts.
- Insert the plug connector at the back of the refrigeration appliance (see “Installation – Electrical connection”).
- Insert the plug ⑥ into the socket.

The electrical socket must not be concealed behind the appliance and must be easily accessible in an emergency.

**⚠ Risk of damage due to electrical overload.**

If the refrigeration appliance is electrically overloaded, this can cause a short circuit and thus damage your refrigeration appliance. When you install appliances side by side, each refrigeration appliance must have its own separate electrical socket.

**Tip:** Secure the power cable to prevent it becoming caught: tie a piece of string to the middle of the cable and as the refrigeration appliance is being pushed into the niche, pull the cable forward underneath the appliance.

- Carefully push the refrigeration appliance into the niche.

# Installation

- If the refrigeration appliance cannot be pushed into the niche (because the floor is uneven, for example), unscrew the rear adjustable feet slightly (see “Installation – Aligning the refrigeration appliance”) and slide the refrigeration appliance into the niche.
- Remove the edge protection ⑤ from the adjacent furniture fronts.

## Aligning the refrigeration appliance

The installation aids ① on the appliance door provide assistance with the alignment of the refrigeration appliance in the building-in niche.

The installation aids are suitable for a furniture front thickness of 19 mm or 38 mm.

- Align the refrigeration appliance with adjacent furniture fronts as described below.

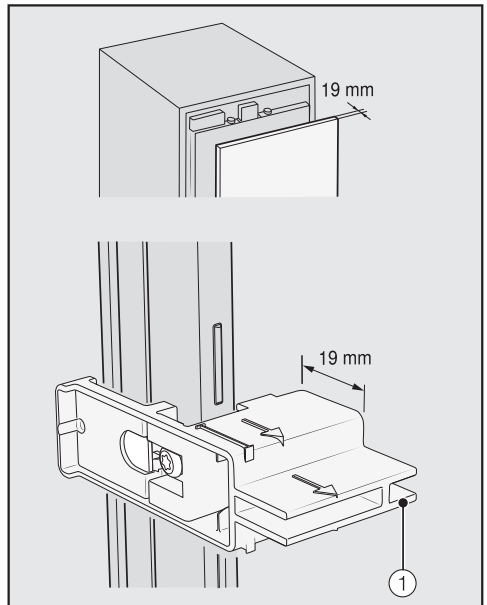

Furniture front thickness of 19 mm



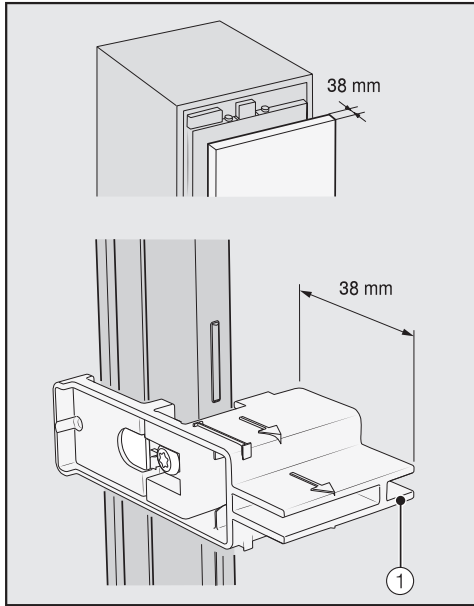

Furniture front thickness of 38 mm

The adjustable feet at the front and back of the appliance can all be adjusted from the front of the appliance.

 Risk of damage due to incorrect feet adjustment.

You may damage the adjustable feet if you use a cordless screwdriver. Always adjust the front and rear feet by hand.

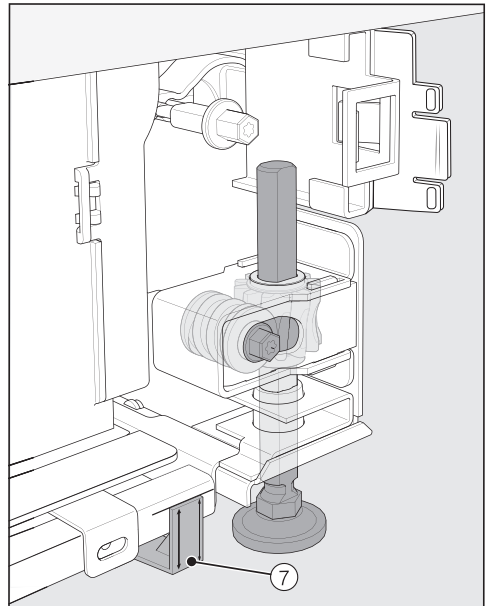

- Position the supplied spacers ⑦ on both sides on the markings next to the adjustable feet at the front of the refrigeration appliance.

# Installation

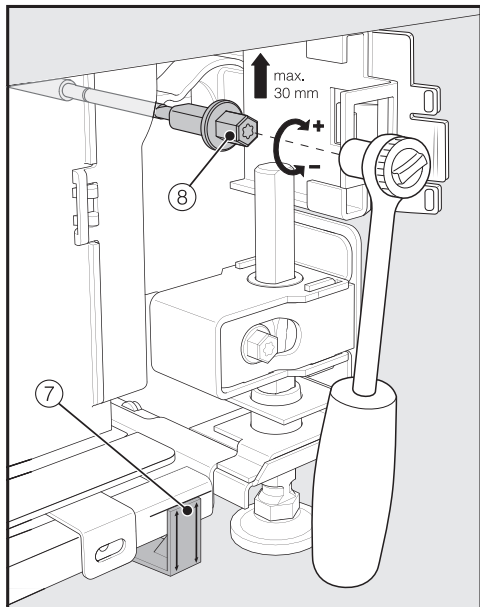

- Adjust the rear feet with a ratchet (attachment: socket, 8 mm) or a TX 20 screwdriver ⑧.

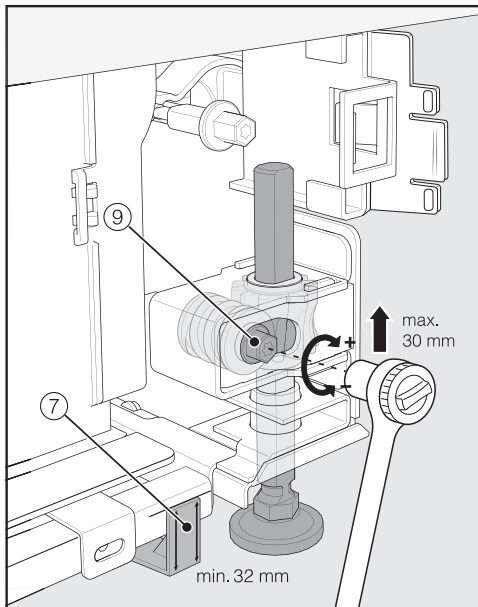

- Adjust the front feet with a ratchet (attachment: socket, 8 mm) or a TX 20 screwdriver ⑨.

**Tip:** Proceed carefully when adjusting the feet, alternating between the left and right feet.

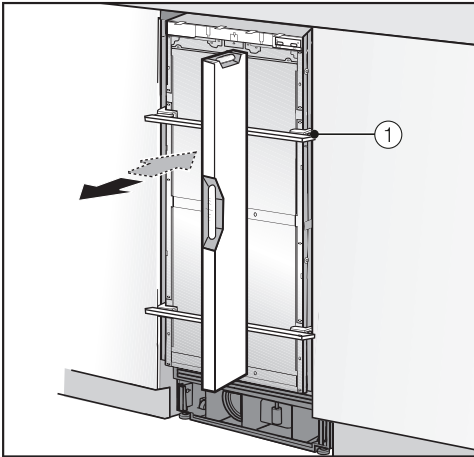

- Check the alignment of the refrigeration appliance again using the installation aids ① and the spirit level.

## Securing the refrigeration appliance in the building-in niche

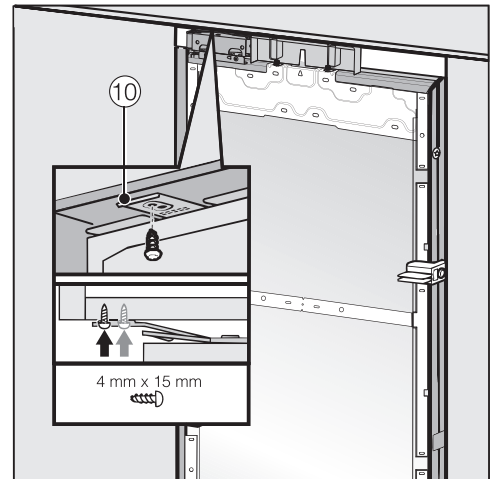

- Screw the lugs for the fixing plate ⑩ into the cabinets/units above the appliance.

- Place a spirit level across the installation aids ① on the appliance door to check the refrigeration appliance's alignment.
- Unscrew the adjustable feet ⑧ and ⑨ on both sides at least until the marking on the plinth has reached the specified distance of 32 mm on the spacer ⑦. The standard dimension of 32 mm relates to a niche height of 2134 mm.

It is important to adjust the feet to a height of at least 32 mm so that the ventilation of the refrigeration appliance via the plinth functions correctly.

 Risk of damage if the feet are adjusted too much.

The rear adjustable feet can be damaged.

Unscrew the feet **only until** the marking on the plinth is aligned to a maximum of 62 mm (max. niche height of 2164 mm).

# Installation

If it is not possible to secure the refrigeration appliance at the top, it can be attached to the building-in niche with the side fixing plates:

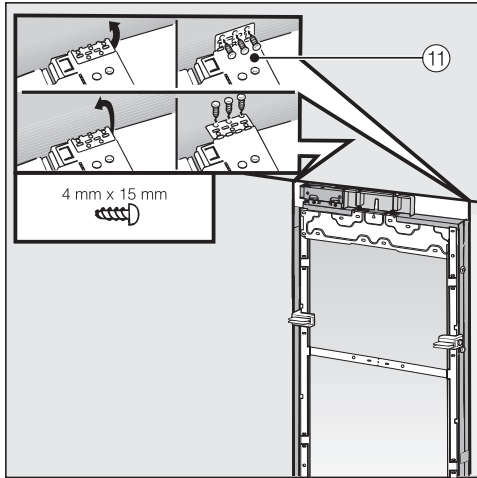

- Open out the side fixing lugs ⑪.
- Screw the side fixing lugs ⑪ to the adjacent cabinets/units.

- Open the appliance door.

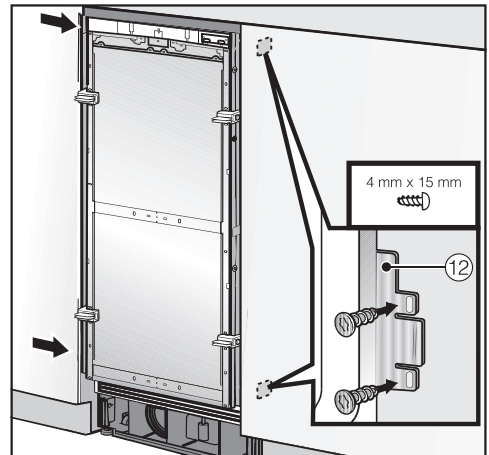

- Screw the fixing plate lugs ⑫ at the top and bottom to the cabinets/units adjacent to the appliance.

In a side-by-side combination, only the external panels of the two refrigeration appliances can be secured to the furniture wall.

## Preparing to install the furniture fronts

- Open the appliance door as far as it will go.

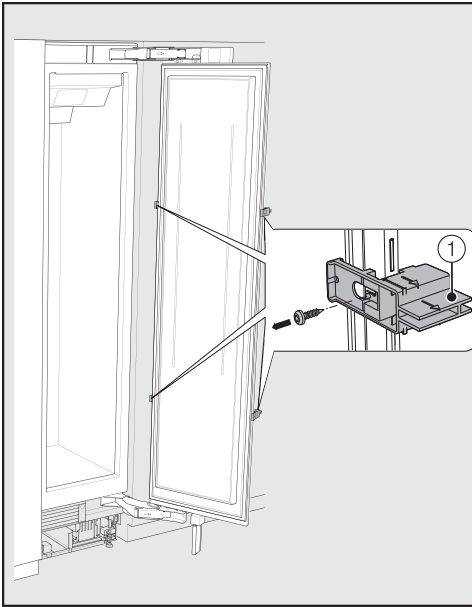

- Unscrew the installation aids ① from the appliance door.

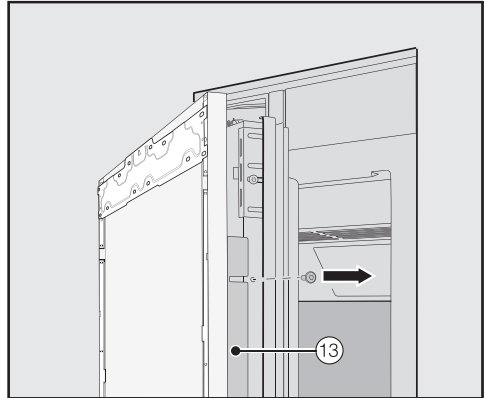

- Unscrew the angle trims ⑬ from both sides of the appliance door and place the trims and screws to one side – they will be required later.
- Close the appliance door.

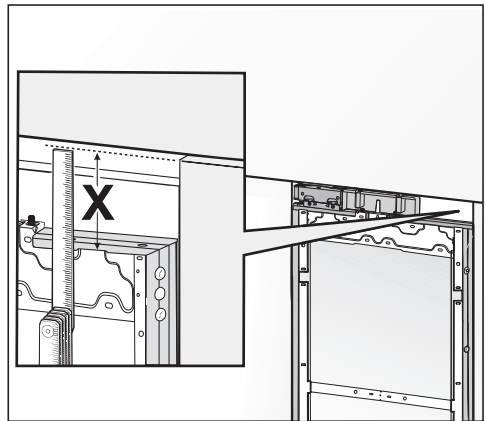

- Measure the gap X between the mounting frame and the upper edge of the adjacent furniture front.

# Installation

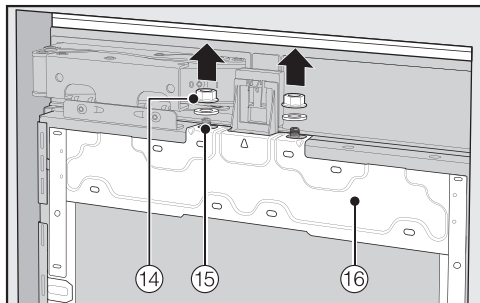

- Remove the nuts and washers (14) from the threaded bolts (15) and place them to one side – they will be required later.
- Take the mounting frame (16) off the appliance door by removing it upwards.

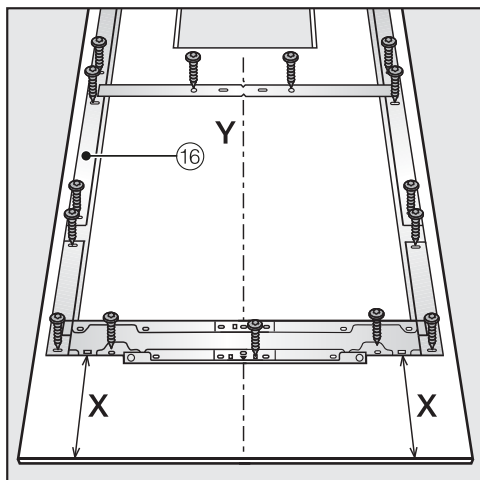

- Place the furniture front on a firm surface, with the external side facing downwards (place on a blanket or similar to prevent it from becoming scratched).
- Mark the distance **X** - 3 mm on the inner side of the furniture front.
- Also locate and mark the centre point **Y** on the furniture front.

- Position the mounting frame (16) according to the markings on the furniture front.
- Pre-drill the holes.



- Screw the mounting frame (16) to the furniture front. Use at least one screw for each retaining point on the mounting frame (16).

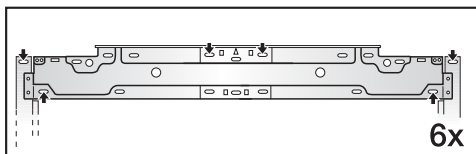

- Secure the mounting frame (16) to the top of the furniture front, using at least 6 screws depending on the size.

The mounting frame has several different types of holes to take account of a variety of furniture fronts. When securing the frame, always screw into the strongest part of the furniture front. To do this, select screws which are slightly shorter than the thickness of the furniture front.

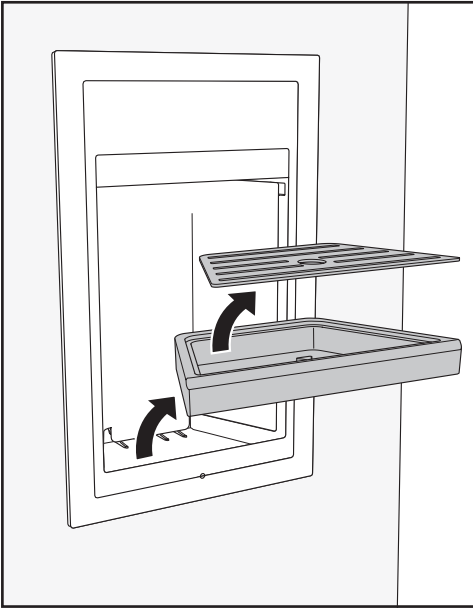

- Remove the drip tray grille and the drip tray from the Ice/Water dispenser.

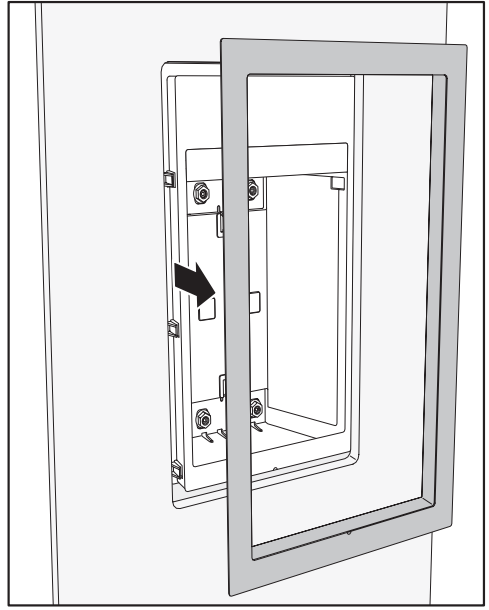

- Remove the frame from the Ice/Water dispenser.
- Screw the appliance handle to the furniture front from the inside if necessary (not for handle-free kitchens).

# Installation

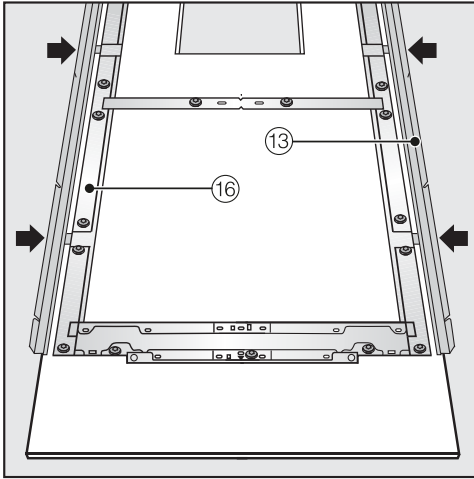

- Now insert the angle trims ⑬ on both sides as far as they will go into the provided spaces in the mounting frame ⑯.

## Securing and aligning the furniture front

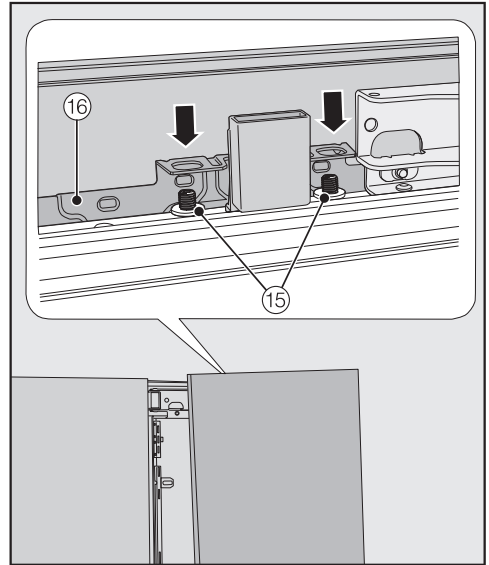

- Open the appliance door and hang the furniture front on its frame ⑯ onto the threaded bolts ⑮.



**E**

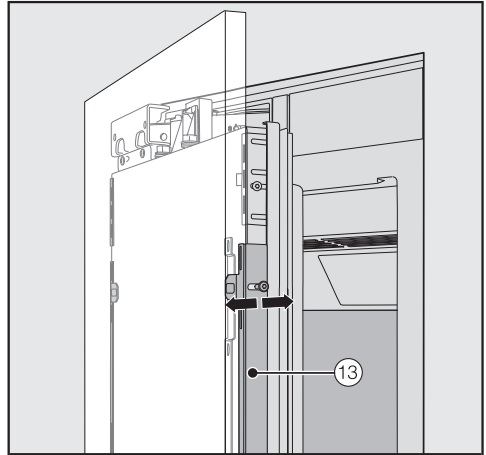

- Press the angle trims 13 into the white plastic frame on both sides from the outside and screw them on loosely at first. Spare screws are provided in the plastic bag marked with the letter E.

- Align the depth of the furniture front via the gaps in the angle trims 13.

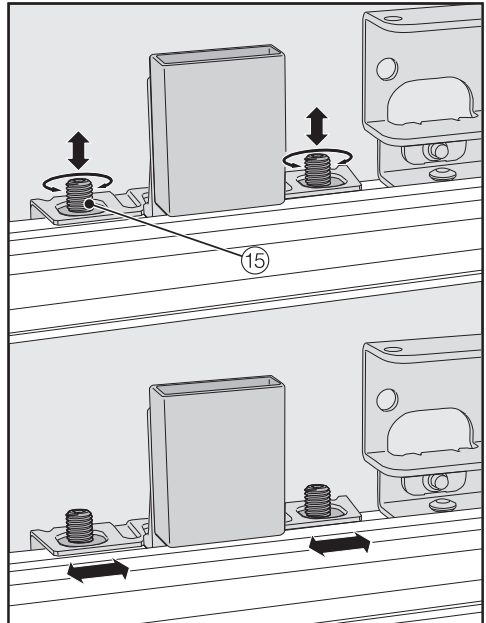
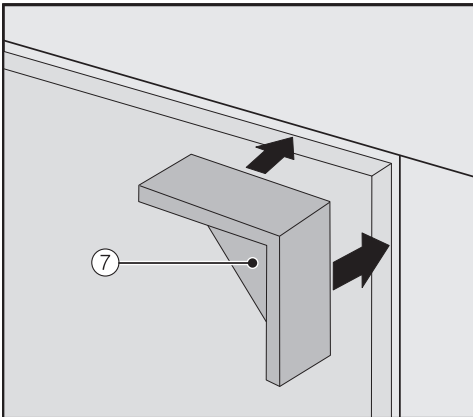

- Place the spacers 7 on top of the corners of the furniture front on both sides.
- Close the appliance door and check the distance between the door and adjacent furniture fronts again.

- Align the height and sides of the furniture front using the threaded bolts 15.
- Close the appliance door and check the distance between the door and adjacent furniture fronts again.

# Installation

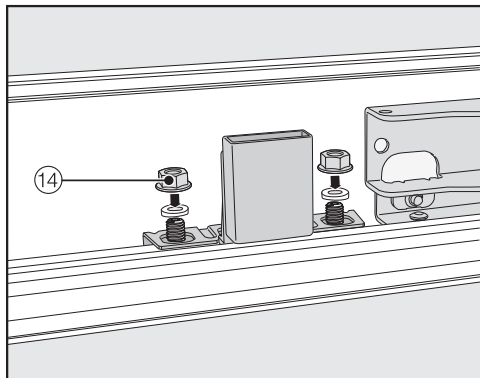

- Place the washers and nuts ⑭ back in position and tighten the nuts ⑭. The furniture front is now secured.

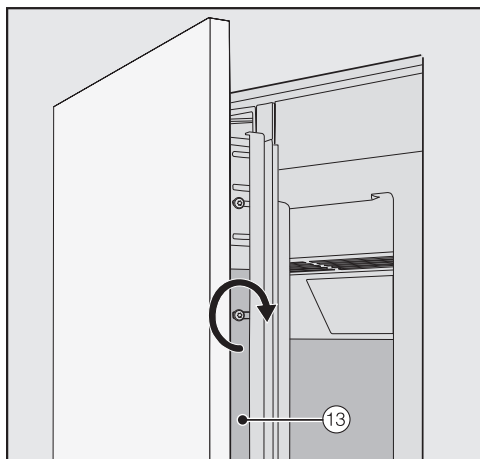

- Now tighten the screws in the angle trims ⑬.
- Open the appliance door.
- Remove the spacers ⑦ from the furniture front.

## Mounting the fixing bracket



The fixing bracket is used to secure the furniture front to the bottom of the appliance door.

Do not mount the fixing bracket until the refrigeration appliance (or side-by-side combination, if applicable) has been installed and the furniture front has been aligned.

- Open the appliance door as far as it will go.

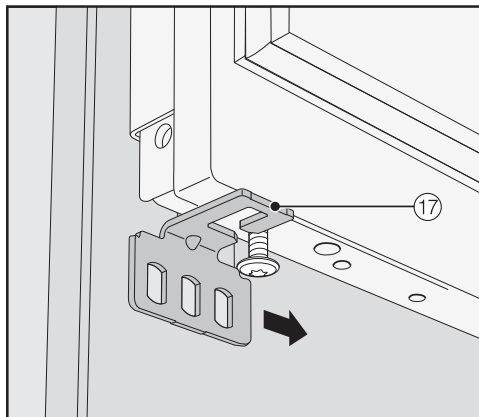

- Slide the fixing bracket ⑰ sideways onto the screw at the bottom of the appliance door.

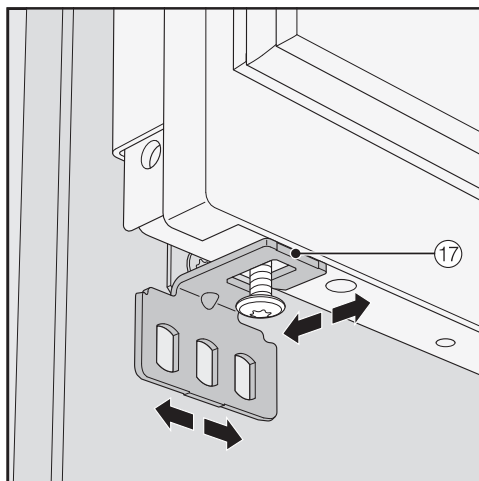

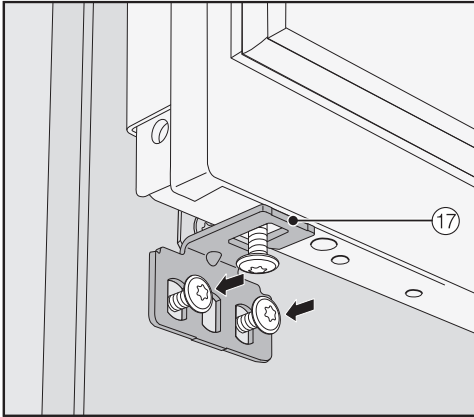

- Screw the fixing bracket 17 securely to the furniture front.

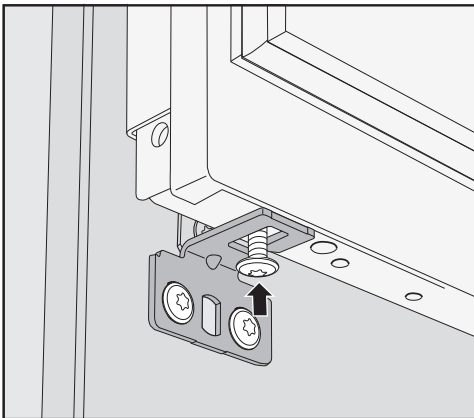

- Tighten the screw at the bottom of the appliance door.

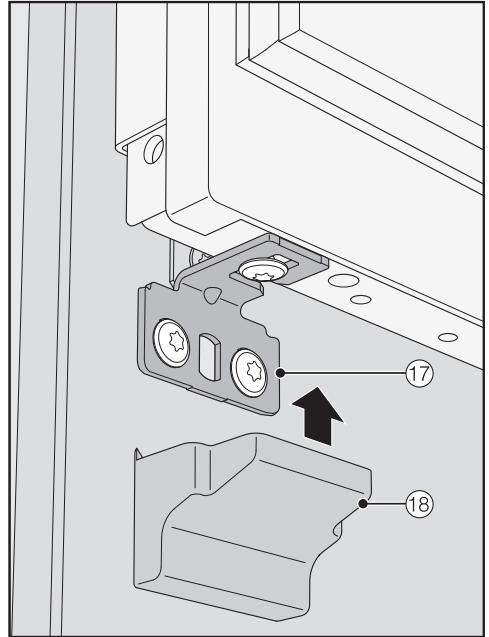

- Fit the cover 18 over the fixing bracket 17.

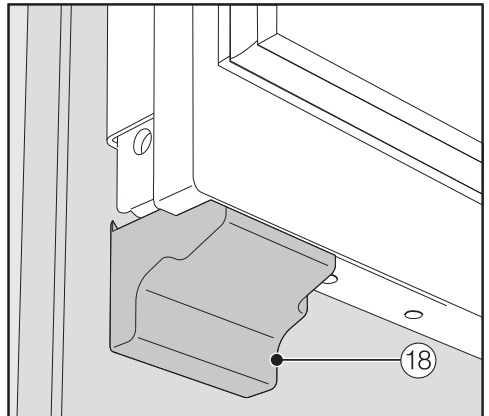

- Click the cover 18 onto the fixing bracket.

# Installation

## Securing the covers

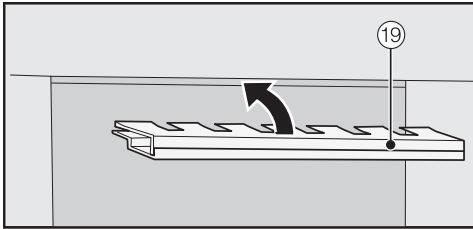

- Before the cover ⑱ can be installed in the gap above the refrigeration appliance, it must be assembled as follows:

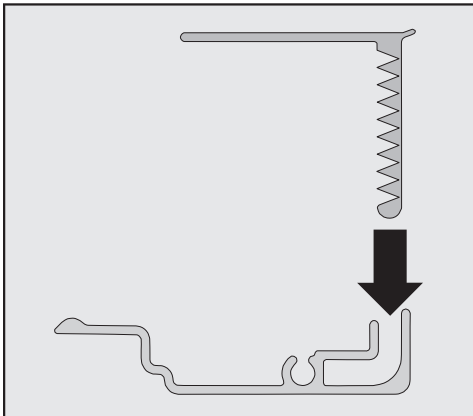

- Insert the two parts of the cover into one another.

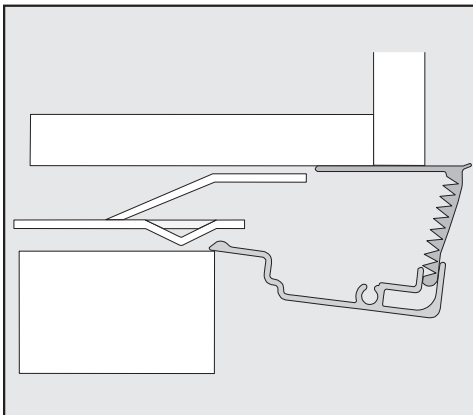

Cover viewed from the side

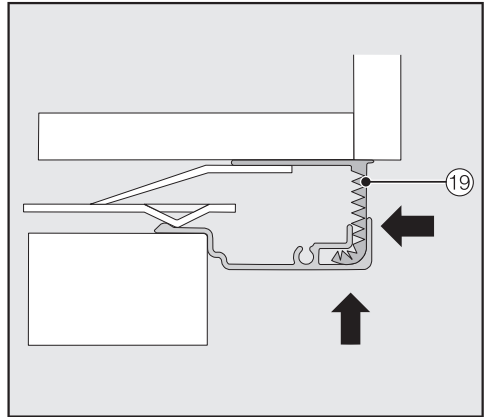

- Place the assembled cover ⑱ into the gap above the refrigeration appliance so it clicks into place. While doing so, slide both parts of the cover together as required.

## Installing the cover in a side-by-side combination

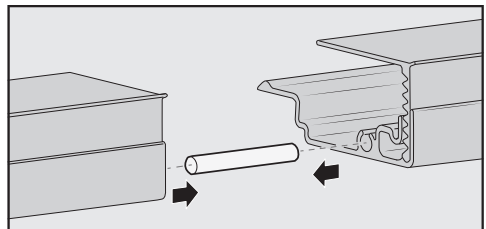

- Insert the pin (from the side-by-side installation kit) halfway into the channel in the cover for the left-hand refrigeration appliance.
- Place the second cover onto the pin and press the two covers together.
- Click the two covers together into the gap above the refrigeration appliances.

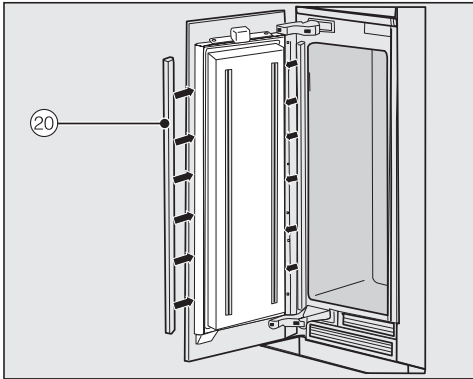

- Fit the plastic covers ⑳ on both sides of the appliance door by clicking them into the gap between the appliance door and the furniture front, starting at the bottom and working up to the top.

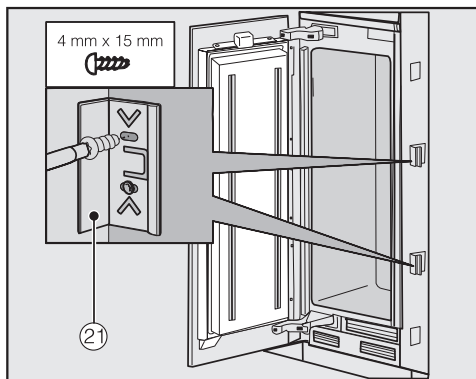

- Secure both sides of the refrigeration appliance using at least 3 clips ㉑ for the covers.

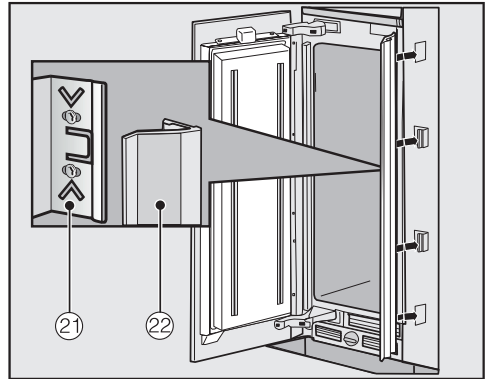

- Now attach the covers ㉒ onto the retaining clips ㉑ on each side. In the case of side-by-side installation, the covers are only required on the outer side.

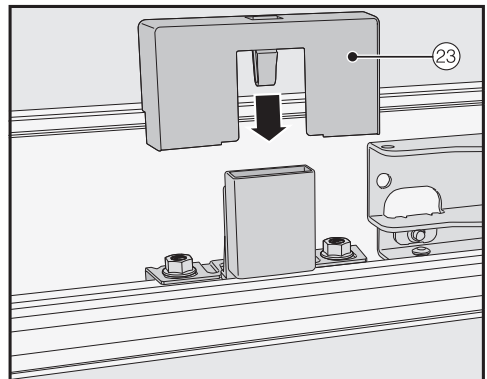

- Fit the cover ㉓ onto the light contact switch.

# Installation

## Securing the plinth ventilation grille and plinth panel

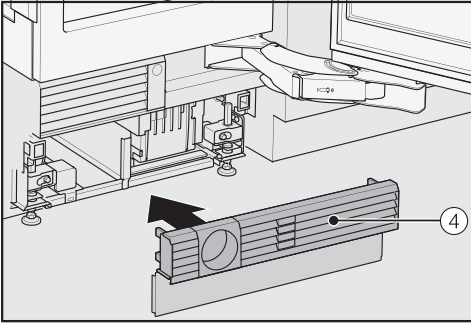

- Click the plinth ventilation grille ④ onto the bottom of the appliance plinth.

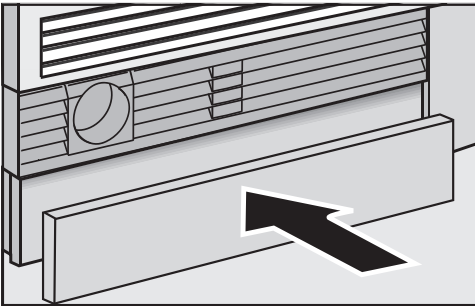

- If necessary, cut the plinth panel to the required length and height (cut along the lower edge of the plinth where it touches the floor).
- Secure the plinth panel to the bottom of the plinth ventilation grille.

## Aligning the Ice/Water dispenser

If necessary, the depth of the Ice/Water dispenser can be aligned to line up with the furniture front.

Switch off at the wall and withdraw the plug from the socket, or disconnect the fuse.

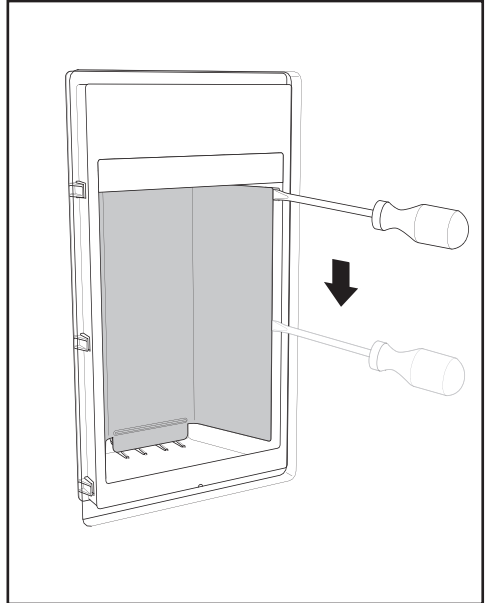

- Carefully insert a screwdriver from the side to remove the rear cover from the dispensing unit.

Proceed with great care to avoid scratching the cover when removing it.

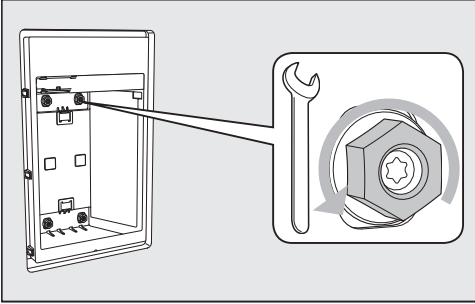

- Use an open spanner to loosen the nuts at the back of the Ice/Water dispenser slightly by turning the nuts anti-clockwise.

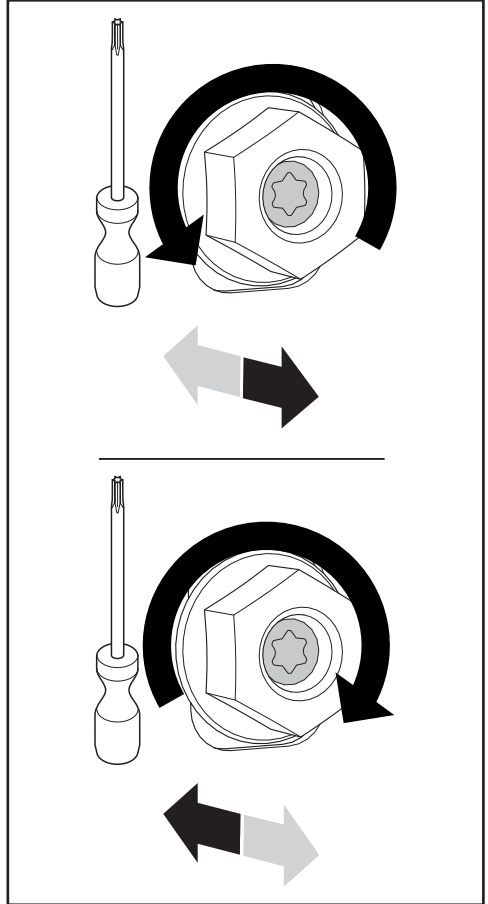
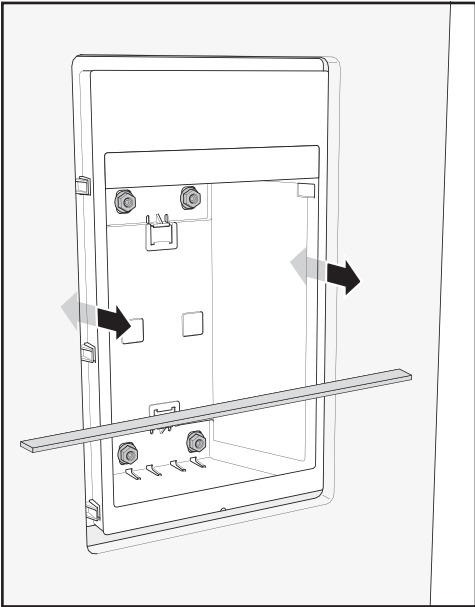

- Then use the 4 screws to line up the depth of the Ice/Water dispenser on both sides.

## Installation

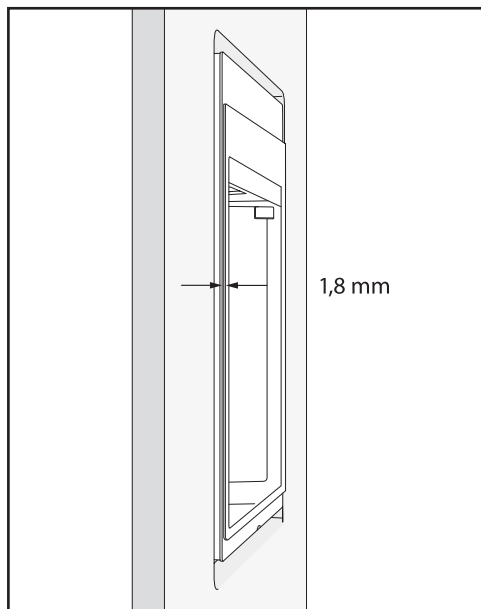

The protrusion from the inner to the outer frame should be 1.8 mm.

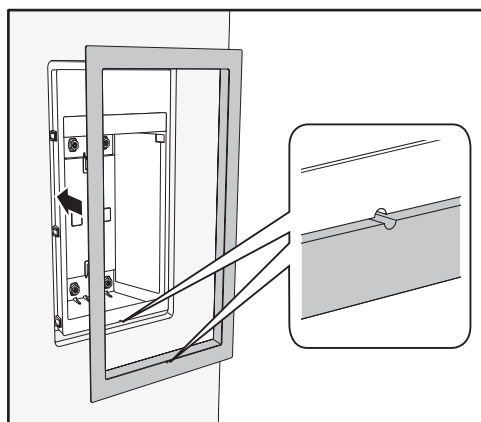

■ Align the frame perfectly with the Ice/Water dispenser.

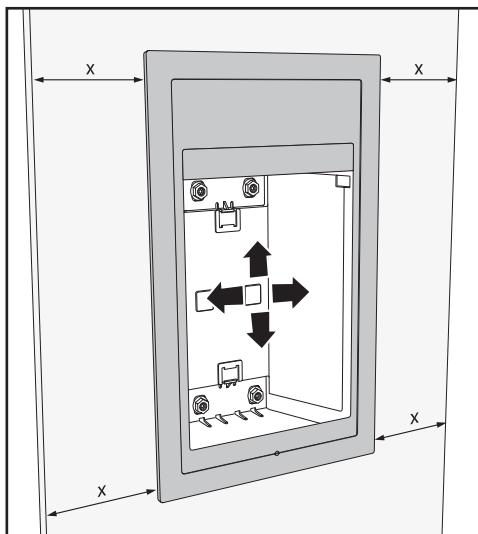

- Align the frame centrally.
- Finally, use an open spanner to tighten the nuts by turning them clockwise.



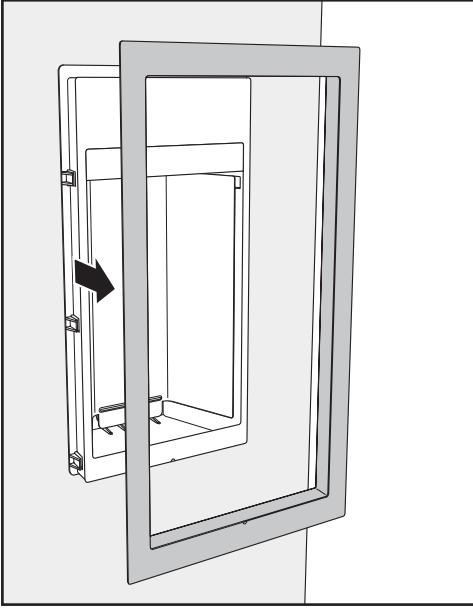

- Remove the frame again.



- Remove the film from each of the adhesive strips.



- Attach the adhesive strips provided to the 4 sides of the frame.

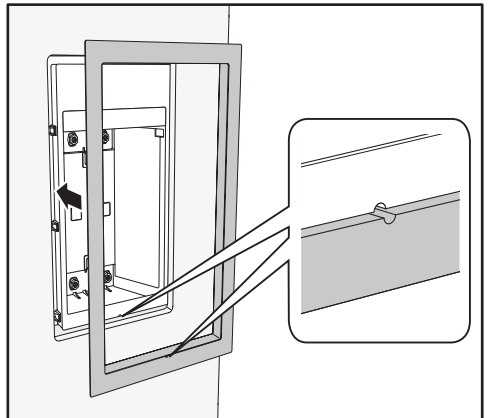

- Align the frame again perfectly with the Ice/Water dispenser.

# Installation

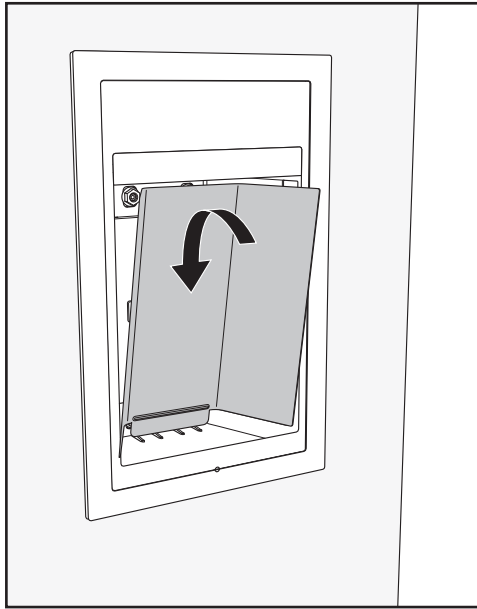

- Refit the rear cover to the Ice/Water dispenser, slotting it into place from above.

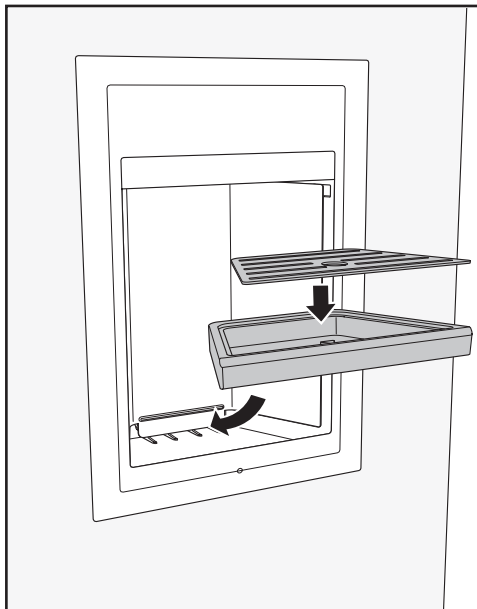

- Insert the drip tray and the drip tray grille.

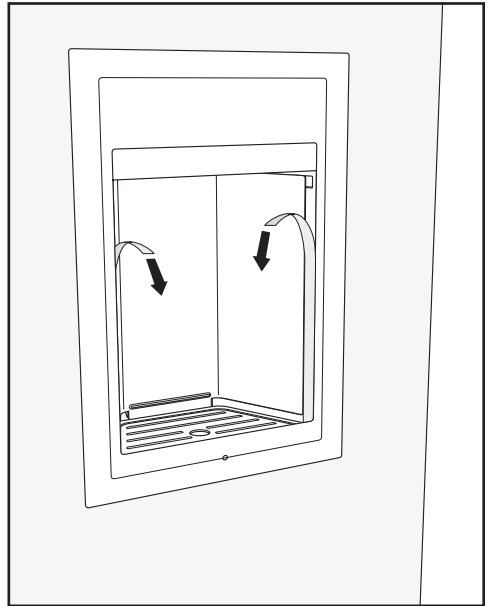

- Then remove the film from both sides of the Ice/Water dispenser.

## Mains water connection

### Information about the mains water connection

 Risk of injury and appliance damage if appliance is not connected properly.

Failing to connect the appliance properly can result in personal injury and/or material damage.

The appliance may only be connected to the mains water connection by suitably qualified specialists.

 Disconnect the refrigeration appliance from the power supply before connecting it to the mains water supply.

Close the stopcock before connecting the refrigeration appliance to the mains water supply.

 Risk to health and risk of damage due to contaminated water.

The quality of the incoming water must conform to the requirements for drinking water in the country where the refrigeration appliance is being used.

Connect the refrigeration appliance to the drinking water supply.

This refrigeration appliance meets the requirements of IEC 61770 and EN 61770.

Connection to the water supply must comply with the applicable regulations in the country where the appliance is being installed. All appliances and systems used to supply water to the refrigeration appliance must also comply with the applicable regulations in the respective country.

The water connection pressure needs to be between 200 kPa and 800 kPa (2 bar and 8 bar).

 Risk of damage due to excessive water connection pressure.

Excessive water connection pressure in the water line can cause damage to the refrigeration appliance.

You must install a pressure reducing valve if the water connection pressure in the water line exceeds 800 kPa (8 bar).

With the pressure reducing valve installed, the maximum water connection pressure at the hose set of the refrigeration appliance cannot exceed 1000 kPa (10 bar).

Contact a plumbing specialist if you are unsure of your water connection pressure.

Use fresh water to ensure that the quality of the ice cubes remains high. Connect the stainless steel hose to the fresh water supply and avoid connection to a water supply in which the water might stagnate.

Only use the stainless steel hose supplied. The stainless steel hose must not be shortened, extended or replaced by a different hose.

# Installation

The stainless steel hose must only be replaced by an original Miele spare part. The food-grade, stainless steel hose is available to order from the Miele webshop, from the Miele Customer Service Department or from your local Miele dealer.

A stopcock must be provided between the stainless steel hose and the mains water supply to ensure that the water supply can be cut off if necessary.

Make sure that the stopcock is still accessible after the refrigeration appliance has been installed.

The stainless steel hose is 2 m long and is already installed on the refrigeration appliance when it is delivered.

## Connecting the refrigeration appliance to the water supply

By this time, the installation niche should already have been prepared so that the refrigeration appliance needs only to be pushed into it.

When doing so, make sure that the stainless steel hose is not kinked or damaged.

- Position the refrigeration appliance slightly in front of the installation niche so that the stopcock can still be accessed.

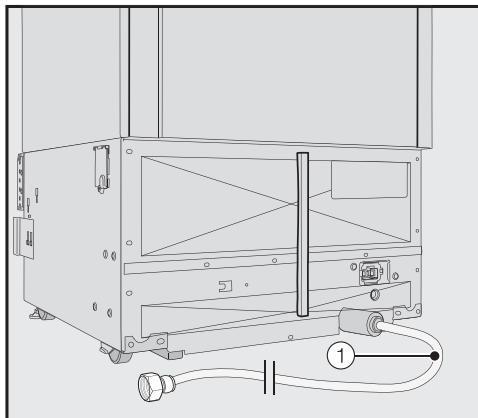

The stainless steel hose for the refrigeration appliance ① is ready for connection at the rear of the appliance.

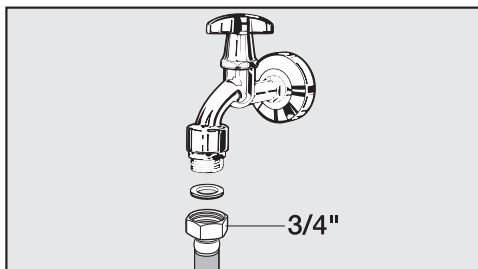

- Connect the stainless steel hose ① to the stopcock.
- Ensure that the threaded union is properly connected and does not leak.
- Slowly open the water supply stopcock and check the whole water system for leaks.
- The appliance can now be installed in the niche (see “Installing the refrigeration appliance” in “Installation”).

## Electrical connection

The refrigeration appliance must only be connected to an earthed socket using the mains connection cable supplied.

The socket must be easily accessible after the refrigeration appliance has been installed. If the socket is not easily accessible, ensure that a suitable means of disconnection is provided on the installation side for each pole.

 Risk of fire from overheating.

Connecting the refrigeration appliance to a multi-socket plug adapter or to an extension lead can overload the cable.

For safety reasons, do not use an extension lead or multi-socket adapter.

The electrical installation must comply with VDE 0100 requirements.

For safety reasons, we recommend using a type  residual current device (RCD) in the assigned electrical installation for connecting the refrigeration appliance.

If the mains connection cable is damaged, it must only be replaced with a specific mains connection cable of the same type (available from the Miele Customer Service Department). For safety reasons, such replacement may only be carried out by a qualified specialist or the Miele Customer Service Department.

These operating instructions and the data plate indicate the nominal power consumption and the appropriate fuse rating. Compare this information with the data of the on-site electrical connection. If in any doubt, consult a qualified electrician.

Temporary or permanent operation on an autonomous power supply system or a power supply system that is not synchronised with the mains power supply (e.g. island networks, back-up systems) is possible. A prerequisite for operation is that the power supply system complies with the specifications of EN 50160 or an equivalent standard. The function and operation of the protective measures provided in the domestic electrical installation and in this Miele product must also be maintained in isolated operation or in operation that is not synchronised with the mains power supply, or these measures must be replaced by equivalent measures in the installation. As described, for example, in the current version of VDE-AR-E 2510-2.

## Connecting the appliance

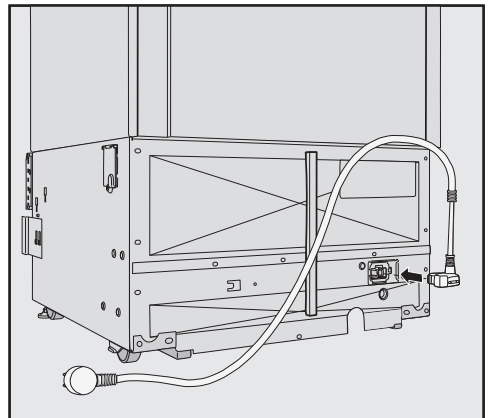

- Insert the plug connector into the socket at the back of the refrigeration appliance.
- Make sure that the plug connector has clicked into position correctly.
- Insert the plug of the refrigeration appliance into the socket.

## Installation

---

The refrigeration appliance is now connected to the electricity supply.

## Saving energy

	<b>Normal energy consumption</b>	<b>Increased energy consumption</b>
<b>Installation / Maintenance</b>	In a ventilated room.	In an enclosed, unventilated room.
	Protected from direct sunlight.	In direct sunlight.
	Not near to a heat source (radiator, oven).	Near to a heat source (radiator, oven).
	Where the ideal ambient room temperature is approx. 20 °C.	Where the ambient room temperature is above 25 °C.
	Ventilation gaps uncovered and dusted regularly.	Ventilation gaps covered or dusty.
<b>Temperature setting</b>	Freezer section -18 °C	The lower the temperature in the appliance, the higher the energy consumption.

# Saving energy

	<b>Normal energy consumption</b>	<b>Increased energy consumption</b>
<b>Use</b>	Drawers and shelves arranged as they were when the appliance was delivered.	
	Only open the door when necessary and for as short a time as possible. Store food in an organised way.	Frequent opening of doors for long periods will cause a loss of coldness. The appliance will try to cool down and the compressor will run for longer periods.
	Take an insulated cool bag when shopping, and load food in the appliance as soon as possible. Allow hot food and drinks to cool down before placing them in the appliance.	Hot food or food at room temperature raises the temperature inside the appliance. The appliance will try to cool down and the compressor will run for longer periods.
	Store food well packaged.	The evaporation or condensation of liquids in the freezer zone will cause a loss of coldness.
	Do not over-fill the appliance to allow air to circulate.	Poor air circulation will cause a loss of coldness.



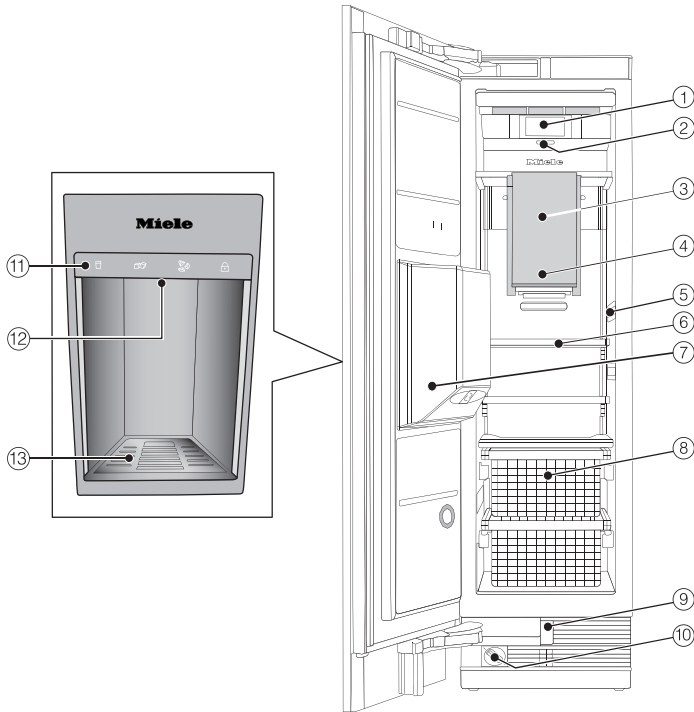



- ① Display
- ② On/Off switch
- ③ Ice cube maker
- ④ Ice cube container
- ⑤ Interior lighting
- ⑥ Shelves
- ⑦ Ice/Water dispensing in the appliance door
- ⑧ Freezer baskets
- ⑨ Automatic door opening (Push2open/Pull2open)
- ⑩ Water filter
- ⑪ Control panel with display
- ⑫ Ice/Water dispenser spout
- ⑬ Drip tray with drip tray grille

# Guide to the appliance

---

## Main screen



- ① SuperFreeze display  
(only visible when the SuperFreeze function has been switched on)
- ② Temperature display (target temperature)
- ③ Sensor control   
for setting the temperature
- ④ Display for Miele@home connection status  
(only visible when the Miele@home function has been set up)
- ⑤ Settings mode   
sensor control for adjusting various settings in Settings mode

## Control panel for Ice/Water dispenser

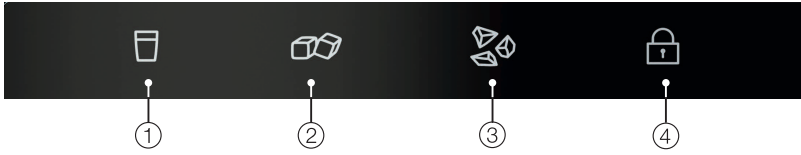









- ① Sensor control for chilled water
- ② Sensor control for ice cubes
- ③ Sensor control for crushed ice
- ④ System lock activation/deactivation







# Guide to the appliance

---





## Settings mode

In Settings mode, you can select the following appliance functions and alter their settings to some extent:

Symbol		Function
	Language	Set
	Display brightness	Adjust (darker to brighter)
	Colour scheme	Set (dark or bright)
	Buzzer tones	Adjust the volume or switch off the Buzzer tones completely (e.g. for the door alarm)
	Keypad tone	Adjust the volume or switch off the Keypad tone completely
°F/°C	Temperature unit	Set (°Fahrenheit or °Celsius)
	Keypad lock	Switch on or off (see “Selecting additional settings”)
	Eco mode	Switch on or off (see “Selecting additional settings”)
	Self test	The system restarts and is checked for faults or malfunctions (see “Selecting additional settings”)
	Door assistant	(Push2open or Pull2open) Switch on or off (see “Selecting additional settings”)

	Miele@home	Set up, deactivate or query WiFi connection status (see "Selecting additional settings")
	Demo mode	Switch off * (only visible when Demo mode, is switched on see "Selecting additional settings")
	Factory default settings	Reset to default settings (see "Selecting additional settings")
	Dispenser unit lighting	Select the lighting settings for the Ice/Water dispenser (see "Selecting additional settings")
	Dispenser unit	Switch the Ice/Water dispenser on or off (see "Operating the Ice/Water dispenser")
	Sabbath mode	Switch on or off (see "Selecting additional settings")
	Water filter display	Switch on or off or reset (see "Selecting additional settings")

## Symbols in Settings mode

	Scroll in Settings mode or select a setting
	Change a setting (e.g. display brightness)
	Confirm a setting
	Exit the menu level

# Accessories

---

## Accessories supplied

### Appliance plug

### Water filter (IntensiveClear mesh filter)

The IntensiveClear mesh filter, which is already installed in the refrigeration appliance, filters supply water for making ice cubes.

The IntensiveClear mesh filter does not need to be replaced, just cleaned (see “Water filter (IntensiveClear mesh filter)” in “Cleaning and care”).

## Optional accessories

A range of useful Miele accessories and care products are available for your appliance.

### Multi-purpose microfibre cloth

The microfibre cloth is suitable for removing fingerprints and light soiling from surfaces such as stainless steel, glass, plastic and chrome without the use of chemicals.

### Stainless steel front panel

Stainless steel front panels give your refrigeration appliance a high-quality appearance.

Handles and plinth panels are also available in stainless steel look.

### Water filter (IntensiveClear active charcoal filter)

The IntensiveClear active charcoal filter improves the taste and smell of the ice cubes by removing chlorine and other substances from the mains water.

You can replace the IntensiveClear mesh filter installed in your refrigeration appliance with an IntensiveClear active charcoal filter.

Unlike the IntensiveClear mesh filter, the IntensiveClear active charcoal filter does need to be replaced regularly (see “Changing the IntensiveClear active charcoal filter” in “Water filter”).

## Side-by-side installation kit

To install two or more refrigeration appliances next to one another, you will need the side-by-side installation kit (see “Installation – Side-by-side”).

Accessories are available to order via the Miele Webshop, from Miele directly (see back cover for contact details) or from your Miele dealer.

## Before using for the first time

Allow the refrigeration appliance to stand for approx. 1 hour before connecting it to the power supply. This will prevent potential functional problems with the refrigeration appliance.

## Packaging material

- Remove all packaging material from the inside of the appliance.

Always remove all packaging material, including adhesive tape, **before** switching on the refrigeration appliance. The adhesive tape is difficult to remove from cold surfaces.

## Cleaning

Please refer to the relevant instructions in “Cleaning and care”.

- Clean the inside of the appliance and the accessories.

## Choosing the right door assistant (Push2open/Pull2open)

The door assistant helps you to open the appliance door.

You can choose between the two door assistants Push2open and Pull2open (see “Selecting additional settings – Switching on the Door assistant ”).

The default door assistant is Push2open.

- Select the Pull2open door assistant if your refrigeration appliance has a furniture front with a handle.
- Select the Push2open door assistant if your refrigeration appliance has a handle-free furniture front.

## Miele@home

Your refrigeration appliance is equipped with an integrated WiFi module.

Networking is deactivated at the factory.

To use this feature, you will need:

- A WiFi network
- The Miele app
- A Miele user account You can create a user account via the Miele app.

The Miele app will guide you as you connect your refrigeration appliance to your home WiFi network.

Once the refrigeration appliance is connected to your WiFi network, you can use the app to carry out the following activities, for example:

- Call up information on the operating status of your refrigeration appliance
- Change the settings on your refrigeration appliance

# Initial commissioning

---

Connecting your refrigeration appliance to your WiFi network will increase energy consumption, even when the appliance is switched off.

Make sure that the signal of your WiFi network is sufficiently strong in the place where you want to set up your refrigeration appliance.

## Availability of the WiFi connection

The WiFi connection shares a frequency range with other appliances (including microwave ovens and remote control toys). This can give rise to sporadic or even complete connection failures. Therefore, the availability of featured functions cannot be guaranteed.

## Miele@home availability

The ability to use the Miele app depends on the availability of the Miele@home service in your country.

The Miele@home service is not available in every country.

For information about availability, please visit [www.miele.com](http://www.miele.com).

## Miele App

The Miele App is available to download free of charge from the Apple App Store® or from the Google Play Store™.





## Operating the refrigeration appliance

The touch display can be scratched by pointed or sharp objects, e.g. pens.  
Only touch the display with your fingers.  
If your fingers are cold, the touch display may not react.

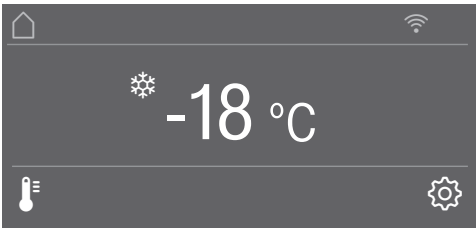

The sensor controls underneath the temperature display can be **selected** directly by touch; the symbols and text in or above the temperature display can only be **displayed**.

## Settings mode

In Settings mode , you can select different refrigeration appliance functions and alter their settings to some extent (see “Selecting additional settings”).

- Touch the  sensor control to open Settings mode.
- Use the < and > sensor controls to select the function for which you wish to adjust the settings.
- Confirm your selection with *OK*.
- Adjust the settings using either the < and > sensor controls or the + and – sensor controls.
- Confirm your selection with *OK*.

The setting with the **coloured** background is always the **selected** setting; it can be confirmed directly with *OK*.

- Touch the  sensor control if you wish to switch to the previous menu level or terminate the process.

Every touch of the display is confirmed with an audible keypad tone. You can switch off this keypad tone in Settings mode .

# Initial commissioning

## Performing initial commissioning

- Open the appliance door.

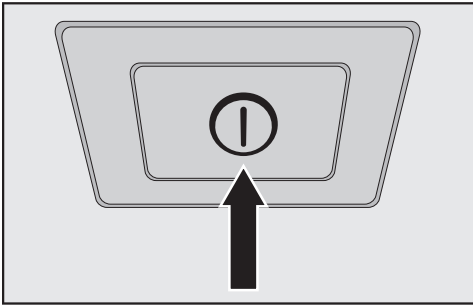



- Switch the refrigeration appliance on by pressing the On/Off switch.

The On/Off switch is located below the display.

The refrigeration appliance will start to cool and the interior lighting will come on when the appliance door is opened.

Miele will appear in the refrigeration appliance display.

- When you switch the refrigeration appliance on for the first time, you will be asked to make the following settings:
  - Set the Language (if you accidentally select the wrong Language, return to Settings mode  and use the  symbol to change the language)
  - Set the Temperature unit: °C (degrees Celsius) or °F (degrees Fahrenheit)
  - Set up Miele@home:
- Select Continue if you would like to set up Miele@home now. You will then be guided by the display and the Miele app.

As soon as your refrigeration appliance has been integrated into your WiFi network, the message Connection successful will appear on your refrigeration appliance's display.

- Confirm the process with OK again.

If the WiFi connection is active,  will appear on the display.

- Select Skip if you would prefer to set up Miele@home later.
- Touch the  sensor control if you want to return to the previous menu level.

Set-up successful will appear in the display.

- Confirm initial commissioning with OK.

The main screen will appear on the display (see “Appliance description – Main screen”).

You cannot terminate the initial commissioning process. The only way to terminate the process is to switch off the refrigeration appliance, though the process will continue when the appliance is switched back on.

## Switching the refrigeration appliance on

- Open the appliance door.
- Switch the refrigeration appliance on by pressing the On/Off switch.

The refrigeration appliance will start to cool and the interior lighting will come on when the appliance door is opened.

Miele will appear on the refrigeration appliance display, followed by the main screen:

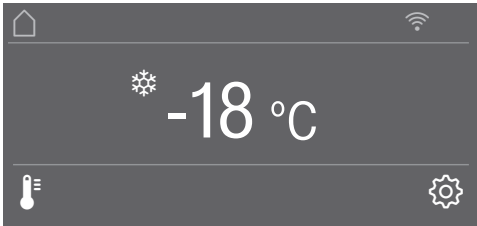

The message Freezer temperature too high. Max. temperature °C will appear on the display when the appliance is switched on for the first time or until the selected temperature has been reached in the freezer zone.

An alarm tone will sound.

- Confirm the message with *OK*.

The message will disappear from the display and the alarm tone will stop.

However, the message may reappear on the display after a brief delay.

As soon as the selected temperature has been reached in the freezer zone, the message will disappear completely from the display and the alarm tone will stop.

To enable the temperature to get sufficiently cold inside the refrigeration appliance, allow the appliance to run for a few hours before placing food in it. Do not place food in the freezer zone until it is cold enough there (at least -18 °C).

 Risk of damage due to high humidity.

In environments with high humidity, condensation can build up on external refrigeration appliance panels. This condensation can cause corrosion and lead to damage on external appliance panels.

Install the refrigeration appliance in a dry and/or air-conditioned room with sufficient ventilation.

Do not switch the refrigeration appliance on if you are going to be away for a long period of time.

Do not leave the refrigeration appliance unattended for a long period of time while it is switched on.

## Switching the refrigeration appliance off

- Switch the refrigeration appliance off by pressing the On/Off switch.

The cooling and interior lighting are switched off.

Please note: the refrigeration appliance is not disconnected from the power supply when it is switched off with the On/Off switch.

# Switching on and off

---

## Switching off for longer periods of time

If the refrigeration appliance is not going to be used for a longer period of time:

- Switch the refrigeration appliance off.
- Switch off at the wall and withdraw the plug from the socket, or disconnect the fuse.

 Risk of damage due to frozen water inlet pipe.

If the water inlet is blocked while the ice maker is still in use, the water inlet pipe can freeze up.

Switch the Ice/Water dispenser off if the water supply is to be interrupted (e.g. during holidays).

- Close the stopcock in the water supply line (approx. 3 hours before switching off the refrigeration appliance to avoid the build-up of mould caused by stagnant water).
- Empty the ice cube container.
- Clean the refrigeration appliance.
- Clean the water filter.
- Leave the door ajar to air the refrigeration appliance and prevent odours from building up inside it.

If, during a long absence, the refrigeration appliance is switched off but not cleaned and the door(s) left shut, there is a risk of mould forming inside the appliance.

It is essential to clean the refrigeration appliance.

## Selecting additional settings

In Settings mode , you can select different refrigeration appliance settings and alter their settings to some extent, allowing you to adjust the appliance to suit your requirements.

Only the functions in Settings mode  that require further explanation are described below.

The door alarm and other warnings are automatically disabled when the appliance is in Settings mode .

### Switching Keypad lock / on or off

Switch Keypad lock on if you wish to protect your refrigeration appliance from unwanted temperature changes or other unintentional adjustments in Settings mode .

- In Settings mode , use the < and > sensor controls to select Keypad lock and select *OK* to confirm your selection.
- Use the < and > sensor controls to switch the sensor lock On or Off and select *OK* to confirm your selection.
- The sensor lock will not be activated until you close the appliance door.

Nothing will appear on the display to indicate that the sensor lock is switched on.

The message Press OK for 6 seconds to unlock will appear on the display if you select a sensor control while the sensor lock is switched on.

- Follow the instructions on the display.

The display is unlocked briefly so you can adjust the setting as required. Closing the appliance door will reactivate the sensor lock.

### Switching Eco mode on or off

Eco mode is useful when you go on holiday, for example, if you do not wish to switch off the refrigeration appliance completely or do not need a high degree of cooling. Energy consumption in Eco mode is lower than in normal operation.

The freezer zone is regulated to a temperature of -16 °C.

If the SuperFreeze function  is switched on, it will be switched off when Eco mode is selected.

- In Settings mode , use the < and > sensor controls to select Eco mode and select *OK* to confirm your selection.
- Use the < and > sensor controls to switch the Eco mode On or Off and select *OK* to confirm your selection.

Only the changed temperature on the display indicates that Eco mode is switched on.

**Tip:** You can also switch off the Eco mode function by directly adjusting the temperature  (see “The correct temperature – Setting the temperature”).

 Health risk caused by decomposing food.

The usability and quality of food may deteriorate if the temperature remains above -18 °C for an extended period.

Only ever switch on the Eco mode function for a limited period.



When switching to Eco mode, check that the food in the freezer zone is already properly frozen.

Do not freeze any new food while the Eco mode function is switched on.

## Selecting additional settings

### Performing a Self test

Perform a Self test if you are concerned that your refrigeration appliance is not working properly and want to check if it is suffering from any problems.

- In Settings mode , use the < and > sensor controls to select Self test and select *OK* to confirm your selection.
- Touch the  sensor control if you wish to terminate the process.

The Self test starts and the refrigeration appliance is checked for any faults or malfunctions.

- The message System restart will appear on the display if the self test does not discover any faults or malfunctions.
- If the self test does discover any faults or malfunctions, they are indicated as error messages on the display.

An alarm will also sound.

- If you find the alarm disruptive, you can switch it off in advance by touching the  sensor control.
- Make a note of the error message(s) displayed.
- Contact the Miele Customer Service Department and inform them of the error message(s) on the display.

- Confirm the message with *OK*.

System restart will appear on the display.

The refrigeration appliance briefly switches off and then back on automatically.

Self test completed will appear on the display.

- Confirm the message with *OK*.

The main screen will appear on the display again.

### Switching on the Door assistant

You can choose between the two door assistants: Push2open and Pull2open. The default door assistant is Push2open.

The Push2open door assistant is suitable for furniture fronts without handles. The appliance door opens automatically when you gently press against it.



The Pull2open door assistant is suitable for furniture fronts with handles. The appliance door can be opened easily with little force.

 Risk of damage if the appliance door is closed prematurely.

When the door assistant is switched on, repeatedly closing the appliance door early can lead to damage or malfunctions.

Refrain from holding onto or closing the appliance door while automatic door opening is still extended. However, if you have closed the appliance door, leave it closed for 5 minutes. Automatic door opening resets itself.



### Switching on Push2open

- In Settings mode , use the < and > sensor controls to select Door assistant and select *OK* to confirm your selection.
- Use the < and > sensor controls to select Mode and select *OK* to confirm your selection.
- Use the < and > sensor controls to select Push2open and select *OK* to confirm your selection.
- Touch the  sensor control to return to the previous menu level.

## Selecting additional settings



### – Adjusting the intensity

You can also adjust the intensity of the Push2open function. The lower the set intensity, the less force required when you push against the appliance door.

- In Settings mode , use the < and > sensor controls to select Door assistant and select *OK* to confirm your selection.
- In Settings mode , use the < and > sensor controls to select Intensity and select *OK* to confirm your selection.
- Use the < and > sensor controls to select the right intensity (Low, Medium, High) and select *OK* to confirm your selection.



### – Adjusting the duration of the AutoClose function

You can also adjust the duration for how long the appliance door will remain open until it closes automatically.

- In Settings mode , use the < and > sensor controls to select Door assistant and select *OK* to confirm your selection.
- In Settings mode , use the < and > sensor controls to select AutoClose and select *OK* to confirm your selection.
- Use the + and – sensor controls to select the duration (5 to 30 seconds) and touch *OK* to confirm your selection.

To protect against inadvertent opening: if you do not pull the appliance open, it will close again by itself after a duration defined by you.

### Switching on Pull2open



- In Settings mode , use the < and > sensor controls to select Door assistant and select *OK* to confirm your selection.
- Use the < and > sensor controls to select Mode and select *OK* to confirm your selection.
- Use the < and > sensor controls to select Pull2open and select *OK* to confirm your selection.
- Touch the  sensor control to return to the previous menu level.

### – Adjusting the intensity



You can also adjust the intensity of the Pull2open function. The lower the set intensity, the less force required when you pull the appliance door.

## Selecting additional settings

---

- In Settings mode , use the < and > sensor controls to select Door assistant and select *OK* to confirm your selection.
- In Settings mode , use the < and > sensor controls to select Intensity and select *OK* to confirm your selection.
- Use the < and > sensor controls to select the right intensity (Low, Medium, High) and select *OK* to confirm your selection.

### Switching off the Door assistant

- In Settings mode , use the < and > sensor controls to select Door assistant and select *OK* to confirm your selection.
- Use the < and > sensor controls to select Mode and select *OK* to confirm your selection.
- Use the < and > sensor controls to select Off and select *OK* to confirm your selection.
- Touch the  sensor control to return to the previous menu level.



# Selecting additional settings

## Miele@home

### Setting up Miele@home

The message **Set up Miele@home** only appears if the refrigeration appliance has not yet been connected to a WiFi network.

- Connect your refrigeration appliance as described in “Before using for the first time”.

### Deactivating Miele@home

- In Settings mode , use the < and > sensor controls to select **Miele@home** and select **OK** to confirm your selection.
- Use the < and > sensor controls to select **Deactivate** and select **OK** to confirm your selection.

Deactivation successful will appear on the display.

- Confirm the message with **OK**.

Your refrigeration appliance is now disconnected from your WiFi network.

The  symbol will go out on the display.

## Activating Miele@home

If you have already activated Miele@home and then disconnected the connection, you will need to reactivate the connection.

- In Settings mode , use the < and > sensor controls to select **Miele@home** and select **OK** to confirm your selection.
- Use the < and > sensor controls to select **Activate** and select **OK** to confirm your selection.

Activation successful will appear on the display.





- Confirm the message with **OK**.

If the WiFi connection is active,  will appear on the display.

## Checking the WiFi connection status

- In Settings mode , use the < and > sensor controls to select **Miele@home** and select **OK** to confirm your selection.
- Use the < and > sensor controls to select **Connection status** and select **OK** to confirm your selection.

Information about the WiFi connection status will then appear on the display:

-  connected: there is a strong connection
-  connected: there is an average connection
-  connected: there is a weak connection
- : disconnected

# Selecting additional settings

## Setting up Miele@home again

If you have changed your WiFi network, you can set up Miele@home again for your refrigeration appliance.

- In Settings mode , use the < and > sensor controls to select Miele@home and select *OK* to confirm your selection.
- Use the < and > sensor controls to select Set up again and select *OK* to confirm your selection.

Reset configuration? will appear on the display.

- Use the < and > sensor controls to select Yes or No and select *OK* to confirm your selection.

## Resetting the network configuration

Reset the refrigeration appliance's settings to the default settings when disposing of your refrigeration appliance, selling it or putting a used refrigeration appliance into operation. This will reset the network configuration so that all personal data is deleted from the refrigeration appliance. This will also ensure that a previous owner is no longer able to access the refrigeration appliance.

- Reset the settings of the refrigeration appliance as described in the chapter "Resetting the settings to their default settings ".

## Switching off the Demo mode

Demo mode allows the refrigeration appliance to be presented in the showroom **without the cooling system being switched on**. This setting is not needed for domestic use.

If Demo mode has been switched on as a default setting,  will show on the display.

- In Settings mode , use the < and > sensor controls to select Demo mode and select *OK* to confirm your selection.

Press *OK* for 4 seconds to deactivate will appear on the display.

- Follow the instructions on the display.

The countdown Demo mode will deactivate in seconds will appear on the display.

Demo mode deactivated. Appliance cooling switched on will appear on the display.

- Confirm the message with *OK*.

The main screen will appear on the display again.

## Selecting additional settings

### Resetting the settings to their default settings

You can reset the refrigeration appliance's settings to their default settings.

Reset the refrigeration appliance's settings to the default settings when disposing of your refrigeration appliance, selling it or putting a used refrigeration appliance into operation. This will reset the network configuration so that all personal data is deleted from the refrigeration appliance. This will also ensure that a previous owner is no longer able to access the refrigeration appliance.

- In Settings mode , use the < and > sensor controls to select Factory default settings and select *OK* to confirm your selection.
- Use the < and > sensor controls to select Reset and select *OK* to confirm your selection.

After a brief delay, Settings reset will appear on the display.













- Confirm the message with *OK*.

The initial commissioning process restarts (see “Initial commissioning – Starting up for the first time”).

The refrigeration appliance's settings will be reset to the following values:

# Selecting additional settings

---

Function	Default setting
	Language English
	Display brightness Middle value (4 of 7 segments)
	Colour scheme Dark
	Buzzer tones Middle value (4 of 7 segments)
	Keypad tone Middle value (4 of 7 segments)
°C/°F	Temperature unit °Celsius
	Keypad lock Switched off
	Eco mode Switched off
	Door assistant Push2open
@	Miele@home Switched off
	Dispenser unit lighting Automatic
	Dispenser unit Switched on
	Sabbath mode Switched off
	Water filter display Switched on
	Temperature -18 °C



## Selecting additional settings

### Selecting settings for lighting the Ice/Water dispenser

In settings mode , you can select settings for lighting the Ice/Water dispenser.



#### Lighting for Ice/Water dispenser switches on automatically

The lighting is automatically switched on when a container is placed under the Ice/Water dispenser.

- In Settings mode , use the < and > sensor controls to select Dispenser lighting and select *OK* to confirm your selection.
- Use the < and > sensor controls to select Mode and select *OK* to confirm your selection.
- Use the < and > sensor controls to select Automatic and select *OK* to confirm your selection.
- Touch the  sensor control to return to the main screen.



#### Lighting for Ice/Water dispenser switches on manually

The lighting is switched on by pressing a button on the control panel of the Ice/Water dispenser.

- In Settings mode , use the < and > sensor controls to select Dispenser lighting and select *OK* to confirm your selection.
- Use the < and > sensor controls to select Mode and select *OK* to confirm your selection.
- Use the < and > sensor controls to select Manual and select *OK* to confirm your selection.
- Touch the  sensor control to return to the main screen.

#### Lighting for Ice/Water dispenser switches off after a certain time

The Ice/Water dispenser lighting switches off after a set time (0–30 seconds).



- In Settings mode , use the < and > sensor controls to select Dispenser lighting and select *OK* to confirm your selection.
- Use the < and > sensor controls to select AutoOff and select *OK* to confirm your selection.
- Set the time you want with the + and – sensor controls. Keeping your finger on the sensor control changes the time continuously.
- Confirm your selection with *OK*.
- Touch the  sensor control to return to the main screen.

#### Switching off the Ice/Water dispenser lighting

The Ice/Water dispenser lighting is switched off completely.

## Selecting additional settings

---

- In Settings mode , use the < and > sensor controls to select Dispenser lighting and select *OK* to confirm your selection.
- Use the < and > sensor controls to select Mode and select *OK* to confirm your selection.
- Use the < and > sensor controls to select Off and select *OK* to confirm your selection.
- Touch the  sensor control to return to the main screen.

### Switching Sabbath mode on or off

The refrigeration appliance has a Sabbath mode to support the observance of religious customs.

When Sabbath mode is switched on, you cannot make any settings on your refrigeration appliance.

Ensure that the appliance door is properly closed, as visual and audible alarms are switched off in Sabbath mode.

- In Settings mode , use the < and > sensor controls to select Sabbath mode and select *OK* to confirm your selection.
- Use the < and > sensor controls to select On or Off and select *OK* to confirm your selection.

When Sabbath mode is switched on,  will appear on the display and the display brightness will be reduced (the display does not change when the appliance door is closed).

When Sabbath mode  is switched on, the following functions are switched off:

- Door assistant  
(for furniture fronts without handles, the appliance door will have to be pulled from the bottom or side)
- Lighting
- All acoustic and visual signals
- Temperature display
- The SuperFreeze function  
(if previously switched on)
- The ice cube maker  
(if previously switched on)

## Selecting additional settings

- The Ice/Water dispenser (if previously switched on)

You can still select:

- The sensor control for Settings mode  so that Sabbath mode can be switched off.

The Sabbath mode function will switch itself off automatically after approx. 125 hours.

 Health risk caused by decomposing food.

As any mains outage during Sabbath mode is not indicated, the frozen food may thaw or defrost. This shortens the shelf life of the food.

Check the quality of the food.

Check whether the frozen food has started to defrost. If it has, check that the food is safe to use and if it is, then use it as soon as possible or cook it before freezing it again.

### Switching on, switching off or resetting the Water filter display

Depending on the quantity of ice cubes produced, the Water filter display will remind you approx. every 6 months that the IntensiveClear mesh filter has to be cleaned. Clean the water filter appears on the display.

See “Water filter (IntensiveClear mesh filter)” in “Cleaning and care” for instructions on how to clean the water filter (IntensiveClear mesh filter).

The first time the mesh filter needs to be cleaned, the display will remind you automatically; the reminder does not need to be switched on separately.

## Selecting additional settings

---

### Switching the Water filter display on

If the Water filter display has been switched off, it must be switched on again if required.

- In Settings mode , use the < and > sensor controls to select Water filter display and select *OK* to confirm your selection.
- Use the < and > sensor controls to select On and select *OK* to confirm your selection.

The Water filter display is now switched on.

### Switching the Water filter display off

- In Settings mode , use the < and > sensor controls to select Water filter display and select *OK* to confirm your selection.
- Use the < and > sensor controls to select Off and select *OK* to confirm your selection.

The Water filter display has been switched off.

### Resetting the Water filter display

After you have cleaned the water filter, you must reset the Water filter display so that it will be displayed automatically again after 6 months.

If you do not reset the display, it appears again and again.

- In Settings mode , use the < and > sensor controls to select Water filter display and select *OK* to confirm your selection.
- Use the < and > sensor controls to select Reset and select *OK* to confirm your selection.

The message Clean the water filter will disappear from the display.

The Water filter display is now activated for the next time the water filter requires cleaning.



# The correct temperature

It is very important to set the correct temperature to ensure the shelf life of food. Reducing the temperature reduces the growth rate of microorganisms. Food does not spoil as quickly.

To freeze fresh food, a temperature of **-18 °C** is required. This will prolong the shelf life of your food and retain its quality.

As soon as the temperature rises above -10 °C, the bacteria become active in the food again so it cannot be kept as long. For this reason, partially defrosted or defrosted food must not be re-frozen. Food may be re-frozen once it has been cooked, as the high temperatures achieved when cooking destroy most bacteria.

The temperature in the refrigeration appliance will rise:

- The more often the appliance door is opened and the longer it is kept open
- The more food is stored in it
- The warmer the food is which is being put into it
- The higher the ambient temperature surrounding the refrigeration appliance This refrigeration appliance is designed for use within specific ambient temperatures (climate range). Do not use in ambient temperatures for which it is not designed.

## Setting the temperature

- Touch the  sensor control to set the temperature.

The previously set temperature will appear.

- Use the + and – sensor controls to set the temperature. Keeping your fingers on the sensor controls changes the temperature continuously.
- Confirm the temperature setting with *OK* or wait approx. 8 seconds after the last touch of the sensor control. The temperature will then be automatically adopted.

**Tip:** The newly set temperature can also be confirmed and adopted by closing the appliance door.

The temperature display always shows the **required** temperature.

If you have adjusted the temperature, **wait for approx. 6 hours if the refrigeration appliance is not very full and for approx. 24 hours if the refrigeration appliance is full** before checking the temperature display. It will take this long for the appliance to give an accurate reading.

- If, after this time, the temperature is still too high or too low, you will need to adjust it again.

# The correct temperature

---

## Temperature range

The temperature can be adjusted from -14 °C to -24 °C.

The ambient temperature in the room and the installation location can affect the time it takes for the appliance to reach the lowest temperature.

If the ambient temperature is too high, the appliance may not reach the lowest temperature.

## SuperFreeze function ❄️

For best results, switch the SuperFreeze function on before putting fresh food into the freezer.

This helps food to freeze quickly and retain its nutrients, vitamins, flavours and appearance.

### Exceptions:

- When you place food that is already frozen in the freezer
- When you only freeze up to 2 kg of fresh food daily

### Switching on SuperFreeze

SuperFreeze should be turned on **4–6 hours before you place food** in the freezer. When you freeze the **maximum amount of food** the SuperFreeze function should be switched on **24 hours beforehand**.

- Touch the  sensor control to set the temperature.
- Touch the ❄️ sensor control to switch the SuperFreeze function on.

The ❄️ symbol will be highlighted in colour and the newly set temperature value of -30 °C will appear on the display.

- Confirm the setting with *OK* or wait approx. 8 seconds after the last press of the button. The setting will be automatically adopted.

The symbol ❄️ will light up on the temperature display.

The refrigeration appliance will now run at maximum power.

### Switching off SuperFreeze

- Touch the  sensor control to set the temperature.

The ❄️ symbol will be highlighted in colour and the temperature value of -30 °C will be shown on the display.

- Touch the ❄️ sensor control to switch the SuperFreeze function off.

The ❄️ symbol will no longer be highlighted in colour and the previous temperature setting will appear again on the display.

- Confirm the setting with *OK* or wait approx. 8 seconds after the last press of the button. The setting will be automatically adopted.

The ❄️ symbol will disappear from the temperature display.

The refrigeration appliance will continue running at normal power.

If you do not turn off the SuperFreeze function, it will turn itself off automatically after approx. 54 hours. The quantity of fresh food placed in the freezer will determine the exact time before the SuperFreeze function turns off.

The refrigeration appliance will then run at normal power again.

**Tip:** To save energy, you should manually switch the SuperFreeze function off once the freezer reaches a **constant** temperature of -18 °C or colder. Monitor the temperature in the freezer zone.

# Temperature and door alarm

The appliance has been fitted with a warning system which ensures that the temperature in the freezer cannot rise unnoticed and to avoid energy being wasted if the door is left open.

## Temperature alarm

The Freezer temperature too high. Max. temperature °C message will appear on the display if the temperature in the freezer zone becomes too warm. An alarm will also sound.

The temperature display will show the highest temperature that was reached during the time in which the temperature rose.

Audible and visual signals will be activated, for example:

- When the refrigeration appliance is switched on and the temperature in the appliance differs greatly from the set temperature
- If a lot of warm room air enters the freezer when frozen food is being loaded, rearranged or taken out
- When large amounts of food are frozen at once
- When fresh food which is still warm is frozen
- After an extended mains outage

The alarm will be silenced and the message on the display will go out as soon as the reason for the alarm has been resolved.

 Health risk caused by decomposing food.

If the temperature in the freezer remains above -18 °C for a long time, the frozen food can start to defrost. This will reduce the storage life of the food.

Check whether the frozen food has started to defrost. If it has, check that the food is safe to use and if it is, then use it as soon as possible or cook it before freezing it again.

## Switching the temperature alarm off early

Before you switch the temperature alarm off, you must determine the cause and rectify it.

If the alarm disturbs you, it can be turned off early.

- Touch the *OK* sensor.

The alarm will stop and the message will disappear from the display.

## Door alarm

An alarm will sound if the appliance door has been left open for longer than 2 minutes.

The message *Close the door* will also appear on the display.

As soon as the appliance door is closed, the alarm tone will stop and the message in the display will go out.

## Switching the door alarm off early

If the alarm disturbs you, it can be turned off early.

- Touch the *OK* sensor control.

The alarm will stop and the message will disappear from the display.

After a certain time, the alarm will sound again and the message will reappear on the display until the appliance door has been closed.

# Adjusting the interior fittings

## Removing or moving the shelves

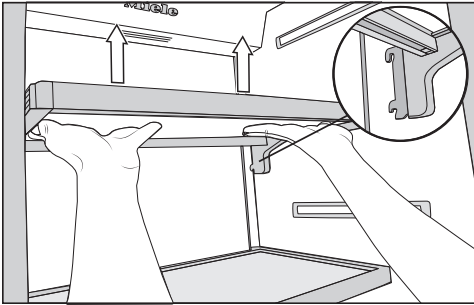

- Use both hands to grip the shelf from below and raise it slightly so that it can be lifted with the catches over the guide at the back.
- Pull the shelf forwards.
- Remove the shelf or place it in the required position, with the catches in the guide again.
- Make sure that the shelf is straight.

## Removing the shelf above the ice maker

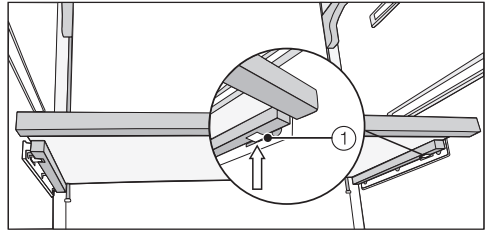

- Use both hands to grip the front of the shelf from below and press it on both sides until you feel resistance ①.

When pulling out and inserting the shelf, make sure that the side walls are not damaged.

- Carefully pull the shelf out to the front.
- To insert it, slide the shelf slowly onto the guide on both sides and then slide it all the way in.

## Removing the freezer baskets

- Open the appliance door as wide as possible.

The opening angle of the appliance door must not be limited to 90° because otherwise the freezer baskets cannot be removed.

- Pull the freezer basket out as far as it will go.

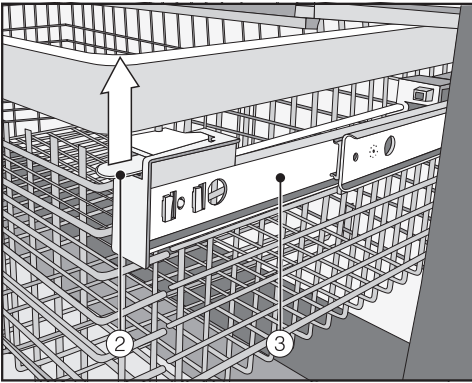

- Raise the snap fastening ② on both sides, unclip and carefully lift the basket out.
- To replace it, pull the telescopic runners ③ out as far as they will go.
- Place the freezer basket back in again.
- Slide the basket all the way back in again until it engages in the snap fastening.

# Freezing and storing food

---

## Maximum freezing capacity

To ensure that fresh food placed in the freezer freezes through to the core as quickly as possible, the maximum freezing capacity must not be exceeded. The maximum freezing capacity for freezing within a 24-hour period is given on the data plate: "Freezing capacity ... kg/24 hrs".

## Freezing fresh food

Fresh food should be frozen as quickly as possible. This way the nutritional value of the food, its vitamin content, appearance and taste are not impaired.

Food which takes a long time to freeze will lose more water from its cells, which then shrink. During the defrosting process, only some of this water is reabsorbed by the cells. What this means in practice is that the food loses more moisture. You can see this in the large amount of water that collects around the food when it defrosts.

If food is frozen quickly, the cells have less time to lose moisture, so they shrink less. As there is not so much moisture loss, it is easier for the food to reabsorb it during the defrosting process, and very little water collects around the defrosted food.

## Storing frozen food

Never re-freeze partially or fully defrosted food. Defrosted food may only be re-frozen after it has been cooked.

When buying frozen food to store in your freezer, check:

- That the packaging is not damaged
- The use-by date
- The temperature at which the frozen food is being stored in the shop.

The length of time food can be kept is reduced if it has been stored at a temperature warmer than  $-18^{\circ}\text{C}$ .

- Buy frozen food once you have finished the rest of your shopping and wrap it in newspaper or use a cool bag or cool box to transport it.
- Put it into the freezer as soon as possible.



## Home freezing

Only freeze fresh food which is in a good condition.

### Hints on home freezing

- The following types of food **are suitable** for freezing:  
Fresh meat, poultry, game, fish, vegetables, herbs, fresh fruit, dairy products, cakes, leftovers, egg yolks, egg whites and a range of pre-cooked meals.
- The following types of food **are not suitable** for freezing:  
Grapes, lettuce, radishes, soured cream, mayonnaise, eggs in their shells, onions, whole raw apples and pears.
- To retain colour, taste, aroma and vitamin C, vegetables should be blanched before they are frozen. To do so place them portion by portion into boiling water for 2–3 minutes. Remove, and plunge into ice-cold water to cool quickly. Drain and pack ready for freezing.
- Lean meat freezes better than fatty meat, and can be stored for considerably longer.
- Separate chops, steaks, cutlets etc. with a sheet of plastic freezer film. This prevents them from freezing together in a block.
- Do not salt or season raw food or blanched vegetables before freezing. Cooked food should only be lightly salted and seasoned. Some herbs intensify the taste of food when frozen.
- Placing hot foods or drinks in the freezer causes food that is already frozen to partially thaw and increases

energy consumption. Allow hot foods and drinks to cool down before placing them in the freezer.

### Packaging food for freezing

- Freeze food in portions.
- **Suitable packing material**
  - Plastic freezer bags
  - Tubular polythene freezer bags
  - Aluminum foil
  - Freezer containers
- **Unsuitable packing material**
  - Wrapping paper
  - Greaseproof paper
  - Cellophane
  - Bin bags
  - Plastic carrier bags
- Expel as much air as possible from the packaging.
- Close the packaging tightly with
  - Rubber bands
  - Plastic clips
  - String
  - Freezer tape

**Tip:** Freezer bags may also be sealed using home heat sealing kits.

- Make a note of the contents and the date of freezing on the packaging.

### Before placing food in the appliance

- When freezing more than 2 kg of fresh food, switch on the SuperFreeze function some time before placing the food in the freezer (see “SuperFreeze”).

# Freezing and storing food

This helps create a cold reserve in food which is already stored in the freezer.

## Placing food in the freezer

Food to be frozen can be placed anywhere in the freezer zone, preferably in the lowest freezer basket.

Place large quantities of food in the large freezer basket.

- Place the food flat in the bottom of the basket so that it freezes through to the core as quickly as possible.
- Make sure that the packaging and containers are dry to prevent them sticking together when frozen.
- Please follow the guidelines in the table below regarding recommended weights for the baskets:

	Upper freezer basket	Lower freezer basket
<b>F 24x2 Vi</b>	12 kg	12 kg
<b>F 26x2 Vi</b>	20 kg	20 kg

Unfrozen food should not touch frozen food as this will cause frozen food to begin to thaw.

## Storage time for frozen food

The storage life of food is very variable, even at a constant temperature of -18 °C. Decomposition processes also take place in frozen food, albeit at a very reduced speed. For example, fat can become rancid from contact with oxygen in the air. This is why lean meat can be stored approx. twice as long as fatty meat.

The storage times quoted are guide values for the storage life of different food groups in the freezer zone.

Food group	Storage time (Months)
Ice cream	2 to 6
Bread, baked goods	2 to 6
Cheese	2 to 4
Fish, oily	1 to 2
Fish, lean	1 to 5
Sausage, ham	1 to 3
Game, pork	1 to 12
Poultry, beef	2 to 10
Vegetables, fruit	6 to 18
Herbs	6 to 10

For standard freezing results, follow the advice on packaging.

By keeping the freezer zone at a constant temperature of -18 °C and taking appropriate hygiene measures you can maximise the storage life of your food and avoid food waste.

## Defrosting frozen goods

Never re-freeze partially or fully defrosted food. Defrosted food may only be re-frozen after it has been cooked.

Frozen goods can be defrosted in different ways:

- In a microwave oven
- In an oven using “Fan heat” or the “Defrost” setting
- At room temperature
- In the refrigerator zone (the cold given off by the frozen food helps to keep the other food cold)
- In a steam oven

**Flat pieces of partially thawed meat or fish** can be placed directly into a hot frying pan.

**Meat and poultry** (e.g. mince, chicken, fish fillets) should not come into contact with other foods while defrosting. Catch the liquid from defrosting and dispose of it carefully.

**Fruit** should be defrosted at room temperature in its packaging, or in a covered bowl.

**Most vegetables** can be cooked while still frozen. Just put straight into boiling water or hot fat. The cooking time is slightly less than that of fresh vegetables due to changes in the cell structure.

## Cooling drinks quickly

When cooling drinks quickly in the freezer, make sure bottles are **not left in for more than one hour**; otherwise they could burst, causing injury and damage.

# Operating the Ice/Water dispenser

The Ice/Water dispenser requires a mains water connection in order for it to operate (see “Installation – Mains water connection”).

If you do not dispense chilled water or ice from the Ice/Water dispenser for a longer period of time, the water/ice may be stale. Regularly dispense water/ice in order to achieve the best water quality.

Risk of injury from broken glass.  
Use a sturdy container for collecting water and ice cubes.

 Risk of injury due to incorrect handling.  
Risk of injury from holding your hands under the Ice/Water dispenser.  
Do not hold your hands under the Ice/Water dispenser.

 Risk of injury due to incorrect handling.  
Risk of injury from reaching into the discharge opening of the ice cube container.  
Never reach into the discharge opening of the ice cube container.

 Risk to health due to contaminated water.  
Consuming polluted water can lead to illnesses.

The first 5 glasses of chilled water as well as the first 30–40 ice cubes made after the Ice/Water dispenser is started up must not be consumed, as the water will have been used for the initial rinse through the water supply line.

This applies to the initial commissioning as well as when using the refrigeration appliance again after it has been turned off for a long time.

 Risk of damage due to blocking of the ice maker.  
The ice maker could become blocked and, as a result, be damaged.  
Do not place any bottles or food into the ice cube container to chill them quickly.

If the Ice/Water dispenser is not used again within 2 minutes or if the appliance door is opened, the Ice/Water dispenser will switch to standby mode automatically and the lighting will go out.  
After it has been activated again, it can take a few seconds before chilled water and ice is dispensed again.

# Operating the Ice/Water dispenser

## Switching the Dispenser unit on

Ice cubes can only be made when the ice cube container is completely closed.

After the appliance door has opened and closed, it can take several seconds until the Ice/Water dispenser is ready for operation and the sensor controls can be operated again.

- In Settings mode , use the < and > sensor controls to select Dispenser unit and select *OK* to confirm your selection.
- Use the < and > sensor controls to select On and select *OK* to confirm your selection.
- Close the appliance door.

The Ice/Water dispenser is now ready for operation.

All sensor controls in the Ice/Water dispenser control panel should now be highlighted in white.

If this is not the case, the system lock has been activated (the  sensor control will be highlighted in white, see “Operating the Ice/Water dispenser – Switching the system lock on/off”).

Once the freezer zone has cooled down to its set temperature, the ice maker will fill with water.

As soon as the water is frozen, the ice cubes drop out of the ice maker into the ice cube container.

Ice cube production is halted automatically when the ice cube container is full.

After the Ice/Water dispenser has been switched on, it can take up to 24 hours until the first serving of ice cubes is ready.

# Operating the Ice/Water dispenser

## Dispensing chilled water

After the initial commissioning, there may be air in the water circuit. Dispense water until there are no more air bubbles.

All materials used in the Ice/Water dispenser are odourless and do not affect flavour.

If you dispense chilled water again after a longer period of time, the water may be stale. In this case, pour away the first 15 glasses of water.

Regularly dispense water/ice in order to achieve the best water quality.

- Place a sturdy container under the Ice/Water dispenser.



- Press and hold the chilled water sensor control.

Chilled water will be dispensed from the spout as long as the sensor control is pressed.

After approx. 30 seconds, dispensing is ended automatically. Wait 5 seconds and press the sensor control again if you wish to dispense more water.

If you want the water to be colder, dispense ice cubes into the container beforehand.

If a large amount of water is dispensed, the water can become warmer.

## Dispensing ice cubes and crushed ice

After the Ice/Water dispenser has been switched on, it can take up to 24 hours until the first serving of ice cubes is ready.

- Place a sturdy container under the Ice/Water dispenser.



- Press and hold the sensor control for ice cubes or crushed ice.

Ice will be dispensed from the spout as long as the sensor control is pressed. After approx. 30 seconds, dispensing is ended automatically. Wait 5 seconds and press the sensor control again if you wish to dispense more ice.

- Take your finger off the sensor control when the container is almost full. Otherwise it will overflow or the ice will block the spout.

The ice maker can make up to approx. 1.3 kg of ice cubes in 24 hours.

The amount of ice cubes produced depends on the temperature in the freezer zone. **The lower the temperature, the more ice cubes are produced within a given time.**

Empty and clean the ice cube container at regular intervals, or at least if you have not produced any ice for longer than a week (see “Cleaning and care – Emptying and cleaning the ice cube container”).

This will ensure that you always have fresh ice and the ice cubes will not form a clump.

# Operating the Ice/Water dispenser

## Switching the Dispenser unit off

- Close the stopcock in the water supply line approx. 3 hours before switching off the refrigeration appliance to avoid the build-up of mould caused by stagnant water.
- In Settings mode , use the < and > sensor controls to select Dispenser unit and select *OK* to confirm your selection.
- Use the < and > sensor controls to select *Off* and select *OK* to confirm your selection.

The Ice/Water dispenser is now switched off; the sensor controls in the control panel are no longer highlighted in white.

## Switching the system lock on/off

You can use the system lock to protect the Ice/Water dispenser from unauthorised use, such as by children.



- Touch the  sensor control until it is highlighted in white and a short tone sounds.

The remaining sensor controls of the Ice/Water dispenser are now locked and cannot be selected.

- To switch off the system lock, touch the  sensor control for approx. 3 seconds until it is no longer highlighted in white and a short tone sounds.

## Automatic defrosting

---

The appliance is equipped with a “NoFrost” system. The refrigeration appliance defrosts automatically.

The moisture generated in the appliance collects on the condenser and is automatically defrosted and dissipated from time to time.

This automatic defrosting system enables the freezer to remain permanently ice-free. Food stored in the freezer will not defrost with this system.



Do not let water get into the electronic unit or the lighting.

 Risk of damage due to moisture ingress.

The steam from a steam cleaner can damage plastic and electrical components.

Do not use a steam cleaner to clean the refrigeration appliance.

The data plate located inside the interior cabinet of the refrigeration appliance must not be removed. It contains information which is required in the event of a service call.

## Cleaning agents

To avoid damaging the surfaces of your appliance, **do not use:**

- Cleaning agents containing soda, ammonia, acids or chlorides
- Cleaning agents containing descaling agents
- Abrasive cleaning agents (e.g. scouring powder, scouring liquid or pumice stones)
- Cleaning agents containing solvents
- Stainless steel cleaning agents
- Dishwasher cleaner
- Oven sprays
- Glass cleaning agents
- Hard, abrasive sponges and brushes (e.g. pot scourers)
- Eraser stain remover blocks
- Sharp metal scrapers

Cleaning and conditioning agents used in the interior cabinet of the refrigeration appliance must be food safe.

We recommend using lukewarm water with a little washing-up liquid for cleaning.

The drip tray grille, back and frame of the Ice/Water dispenser are finished with a high-quality surface coating. This coating is resistant to soiling and is very easy to clean.

## Cleaning and care

---

 Risk of damage due to incorrect cleaning and maintenance.  
The surface coating will be damaged.  
Do **not** treat the drip tray grille, back and frame of the Ice/Water dispenser with

- Stainless steel cleaners:  
The coating will be damaged.
- Miele conditioning agents for stainless steel:  
This will cause noticeable smearing.

 Risk of damage as a result of incorrect cleaning.  
The surface coating will be damaged.  
Do not clean the drip tray or the drip tray grille of the Ice/Water dispenser in the dishwasher.

 Risk of damage caused by adhesives.  
Adhesives will damage the surface coating, causing it to lose its dirt-repellent properties.  
Do not adhere sticky notes, transparent tape, masking tape or other adhesives to parts of the Ice/Water dispenser.

### Before cleaning the refrigeration appliance

- Switch the refrigeration appliance off by pressing the On/Off switch.
- Take any food out of the appliance and store it in a cool place.
- Take out all other removable parts for cleaning (see “Adjusting the interior fittings”).

## Interior cabinet and accessories

Clean the refrigeration appliance regularly, or at least once a month. Remove soiling immediately to prevent it from drying on.

- Clean the interior cabinet of the refrigeration appliance with a solution of lukewarm water and a little washing-up liquid. Rinse all parts by hand. Do not wash in a dishwasher.
- After cleaning, wipe with clean water and dry with a soft cloth.
- Leave the door open to air the refrigeration appliance sufficiently for a short while and to prevent odour build-up.

### Aluminium frames

The frames on the shelves are partially made from aluminium.

Aluminium is a dynamic material. The reflection and appearance of aluminium changes in different lights and environments and depending on the angle you observe it from. It is also susceptible to scratching.

The aluminium frames may become discoloured or damaged if soiling is left on for too long. Remove any soiling from the aluminium frame immediately.

## Cleaning and emptying the ice cube container

Clean the ice cube container regularly. This ensures that fresh ice cubes are always produced.

Empty the ice cube container on a regular basis. This prevents ice cubes from freezing together.

The ice cube container is very heavy when filled. Pull it out using both hands.

- Open the appliance door.

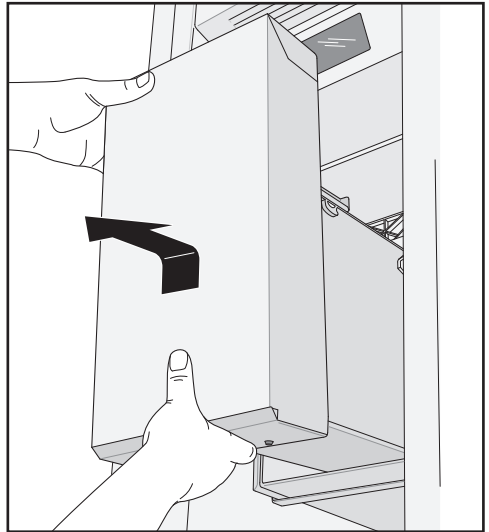

- Lift the ice cube container with both hands and pull it forwards to remove it from the refrigeration appliance.
- Empty the ice cube container and rinse it with warm water.
- Dry the ice cube container thoroughly so that new ice cubes will not freeze onto the surfaces.

## Cleaning and care

- To reinsert the ice cube container, push it into the refrigeration appliance until it clicks into position.
- If you cannot push the ice cube container back in all the way, turn the screw conveyor inside a little.

### Cleaning the drip tray

The drip tray catches excess water.

To avoid a build-up of odour, the drip tray should be cleaned every day.

- Remove the drip tray grille.
- Remove the drip tray and clean it.
- Dry the drip tray with a cloth.
- Reinsert the drip tray and the drip tray grille.

### Cleaning the door seal

 Risk of damage as a result of incorrect cleaning.

If you treat the door seal with oils or grease, it can become porous.

Do not use any oils or grease on the door seal.

- The door seal should be cleaned regularly with clean water, and then wiped dry with a soft cloth.

### Cleaning the ventilation gaps

A build-up of dust will increase the energy consumption of the appliance.

- The ventilation gaps should be cleaned on a regular basis with a brush or vacuum cleaner (you could use a Miele vacuum cleaner dusting brush, for example).

### Cleaning the water filter (IntensiveClear mesh filter)

Depending on the quantity of ice cubes produced, the IntensiveClear mesh filter must be cleaned approx. every 6 months.

Clean the water filter will appear in the display.

- Confirm the message with *OK*.

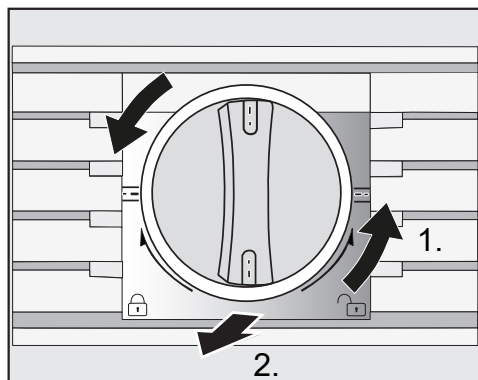

- Turn the cap of the filter cartridge anti-clockwise until it is in the vertical position 1.) and slide it out of the filter opening 2.).

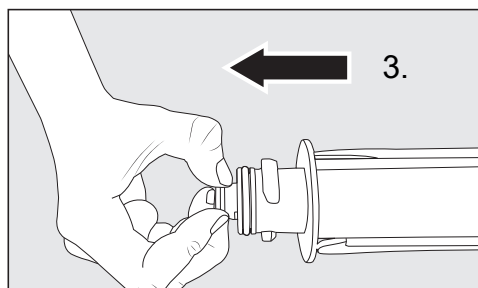

- Pull the filter out of the back of the filter cartridge 3.).

## Cleaning and care

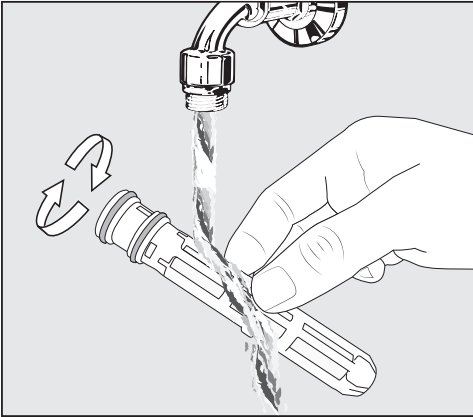

- Rinse the filter under running lukewarm water. Turn the filter over under the running water to clean it on all sides.

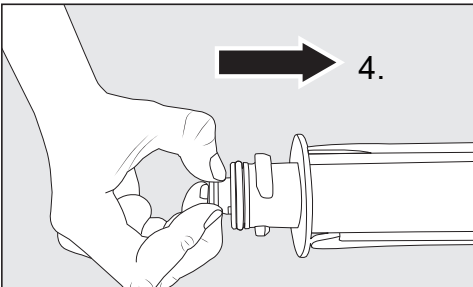

- Reinsert the filter into the back of the filter cartridge 4.).

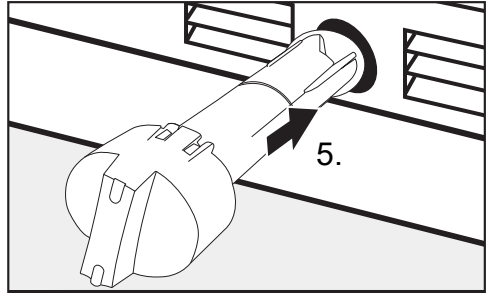

- Slide the filter cartridge as far as it will go into the filter opening 5.), making sure the cap is vertical.

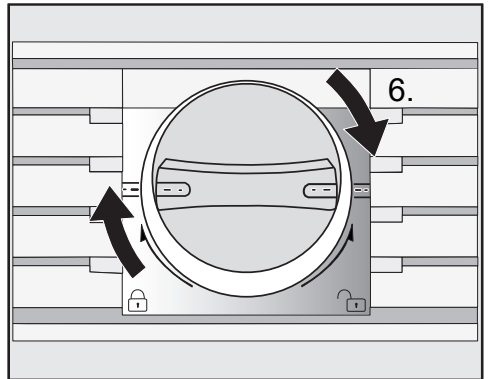



- Turn the cap of the filter cartridge clockwise until it is in the horizontal position 6.).

⚠ Risk of damage caused by water rushing out.

If the filter cartridge is not fitted correctly, there is a risk of water leaking out of the refrigeration appliance.

When fitting the filter cartridge, be sure to turn it as far as the marker.

Once the IntensiveClear mesh filter has been cleaned, the water filter display  must be reset using Settings mode  on the display (see “Resetting the Water filter display ” in “Selecting additional settings”).

# Cleaning and care

---

## After cleaning

- Replace all shelves and accessories in the refrigeration appliance.
- Switch the refrigeration appliance back on.
- Switch the SuperFreeze ❄️ function on for a while so that the freezer zone can cool down quickly.
- Once the freezer zone has reached the required temperature, place the freezer baskets containing the frozen food back in the freezer zone.
- Switch the SuperFreeze ❄️ function off as soon as the temperature in the freezer is a constant -18 °C or colder.

The refrigeration appliance is supplied with a water filter (IntensiveClear mesh filter) that filters mains water for making ice cubes.

The IntensiveClear mesh filter filters suspended particles from the mains water – not bacteria or microbes.

The water filter does not need to be replaced. However, to ensure the highest quality of the ice cubes, it is essential to clean the water filter regularly.

After inserting a new water filter, dispose of all ice cubes produced in the next 24 hours following the change.

Depending on the quantity of ice cubes produced, the IntensiveClear mesh filter must be cleaned approx. every 6 months.

Clean the water filter appears on the display.

- Clean the IntensiveClear mesh filter (see “Cleaning the water filter (IntensiveClear mesh filter)”, in “Cleaning and care”).

## Water filter

### Changing the IntensiveClear active charcoal filter (see “Optional accessories”)

 Risk to health due to contaminated water.

If the IntensiveClear active charcoal filter is not replaced on a regular basis, it may become contaminated.

Change the IntensiveClear active charcoal filter regularly. New IntensiveClear active charcoal filters are available from Miele Customer Service, from your dealer or via the internet.

Only switch off the Water filter display if an external water filter has been attached to your household water supply in place of the IntensiveClear active charcoal filter.

**Tip:** If you have replaced the IntensiveClear mesh filter with an IntensiveClear active charcoal filter, you can use the Water filter display as a reminder to change the IntensiveClear active charcoal filter. The reminder appears approximately every 6 months.

Depending on the quantity of ice cubes produced, the IntensiveClear active charcoal filter needs to be changed approximately every 6 months.

Clean the water filter will appear in the display.

A buzzer also sounds.

■ Confirm the message with *OK*.

#### Please note:

- If an external water filter is attached to your household water supply, use an IntensiveClear mesh filter in place of the previously installed IntensiveClear active charcoal filter (see “Accessories – Optional accessories”).
- After inserting a new water filter (IntensiveClear mesh filter and IntensiveClear active charcoal filter), dispose of all ice cubes produced in the next 24 hours following the change.
- If you have not used the refrigeration appliance or the ice cube maker much in the last few weeks or months, or if the ice cubes smell unpleasant, replace the IntensiveClear active charcoal filter.

Air in the system can cause water to gush out and the filter to spring out when it is removed. Take great care when changing the water filter.

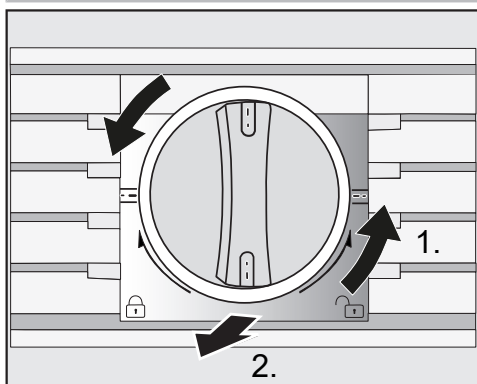

- Turn the cap of the filter cartridge anti-clockwise until it is in the vertical position 1.) and slide it out of the filter opening 2.).



- Remove the safety cap from the new filter cartridge.

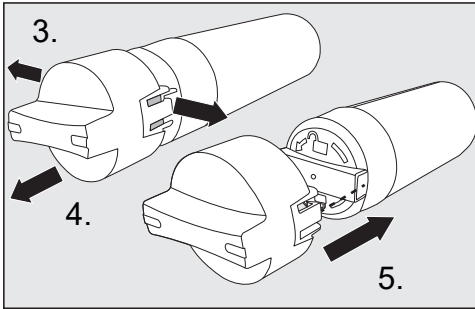

- Loosen the cap from the sides of the old filter cartridge 3.) and remove the cap 4.).
- Clip the cap onto the new filter cartridge 5.).
- Empty the old filter cartridge.

**Tip:** The old filter cartridge can be disposed of with household waste.

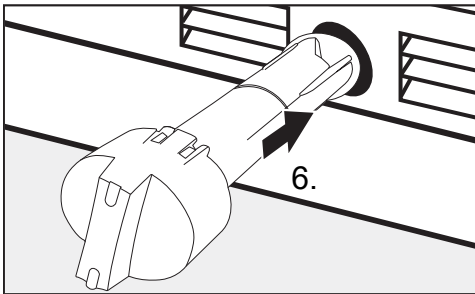

- Slide the new filter cartridge as far as it will go into the filter opening 6.), making sure the cap is vertical.

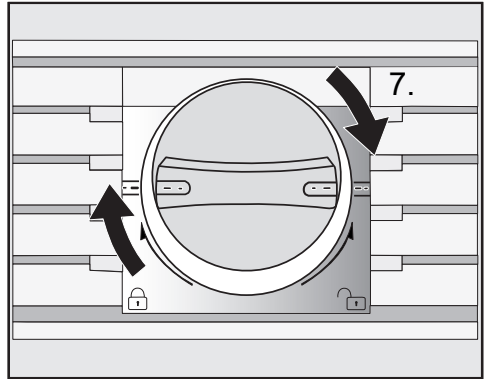



- Turn the cap of the filter cartridge clockwise until it is in the horizontal position 7.).

**⚠ Risk of damage caused by water rushing out.**

If the filter cartridge is not fitted correctly, there is a risk of water leaking out of the refrigeration appliance.

When fitting the new filter cartridge, be sure to turn it as far as the marker.

Once the IntensiveClear active charcoal filter has been replaced, the water filter display  must be reset using Settings mode  on the display (see “Resetting the Water filter display ” in “Selecting additional settings”).

After inserting a new IntensiveClear active charcoal filter, dispose of all ice cubes produced in the next 24 hours following the change.

## Problem solving guide

Many malfunctions and faults that can occur in daily operation can be easily remedied. You can save time and money in many cases, as you do not need to call the Miele Customer Service Department.

Information to help you rectify faults yourself can be found at [www.miele.com/service](http://www.miele.com/service).

The following tables are designed to help you to find the cause of a malfunction or a fault and to resolve it.





To prevent unnecessary loss of temperature it is advisable not to open the door while waiting for the appliance to be serviced.

Problem	Cause and remedy
<p><b>If you are concerned that your refrigeration appliance is not working properly, you can perform a Self test. Your refrigeration appliance will be checked for any faults or malfunctions.</b></p>	<p>Any errors identified during the self test are shown on the display.</p> <ul style="list-style-type: none"> <li>■ Perform a self test (see “Selecting additional settings – Performing a Self test <input checked="" type="checkbox"/>”).</li> <li>■ If necessary, contact the Miele Customer Service Department and inform them of the error message(s) on the display.</li> </ul>
<p><b>The refrigeration appliance is not getting cold and the interior lighting does not come on when the appliance door is opened.</b></p>	<p>The refrigeration appliance has not been switched on.</p> <ul style="list-style-type: none"> <li>■ Switch the refrigeration appliance on. The temperature appears on the display.</li> </ul> <p>The plug is not inserted in the socket correctly.</p> <ul style="list-style-type: none"> <li>■ Insert the plug into the socket.</li> </ul> <p>The mains fuse has tripped. There could be a fault with the refrigeration appliance, the household electrical wiring or another electrical appliance.</p> <ul style="list-style-type: none"> <li>■ Contact a qualified electrician or the Miele Customer Service Department.</li> </ul>

## Problem solving guide

Problem	Cause and remedy
<p><b>The compressor is switching on more frequently and for longer periods of time. The temperature in the refrigeration appliance is too low.</b></p>	<p>The ventilation gaps in the housing unit have been covered or become too dusty.</p> <ul style="list-style-type: none"> <li>■ Do not block the ventilation gaps.</li> <li>■ Dust the ventilation gaps regularly.</li> </ul>
	<p>The appliance door has been opened too frequently, or a large amount of fresh food has been placed inside or frozen at the same time.</p> <ul style="list-style-type: none"> <li>■ Only open the appliance door when necessary and for as short a time as possible.</li> </ul> <p>After a while, the temperature will return to normal by itself.</p>
	<p>The appliance door is not properly closed. A thick layer of ice may have formed in the freezer zone.</p> <ul style="list-style-type: none"> <li>■ Close the appliance door.</li> </ul> <p>After a while, the temperature will return to normal by itself.</p> <p>If a thick layer of ice has already formed, this will affect cooling and increase energy consumption.</p> <ul style="list-style-type: none"> <li>■ Defrost the refrigeration appliance and clean it.</li> </ul>
	<p>The ambient room temperature is too high. The higher the ambient temperature, the longer the compressor has to run.</p> <ul style="list-style-type: none"> <li>■ See the information in “Location” in “Installation”.</li> </ul>
	<p>The refrigeration appliance was not properly installed in the niche.</p> <ul style="list-style-type: none"> <li>■ See the information in “Installation” and “Installing the refrigeration appliance”.</li> </ul>
<p><b>The compressor is switching on more frequently and for longer periods of time. The temperature in the appliance is too low.</b></p>	<p>The temperature setting is too low.</p> <ul style="list-style-type: none"> <li>■ Adjust the temperature.</li> </ul>
	<p>A large amount of food is being frozen at once.</p> <ul style="list-style-type: none"> <li>■ See “Freezing and storing food”.</li> </ul>
	<p>The Super freeze function is still switched on.</p> <ul style="list-style-type: none"> <li>■ To save energy, you can switch the Super freeze function off yourself before this time.</li> </ul>

## Problem solving guide



Problem	Cause and remedy
<p><b>The compressor comes on less and less often and for shorter periods of time. The temperature in the refrigeration appliance rises.</b></p>	<p>This is not a fault. The temperature setting is too high.</p> <ul style="list-style-type: none"> <li>■ Correct the temperature setting.</li> <li>■ Check the temperature again after 24 hours.</li> </ul> <p>The frozen food begins to defrost. The ambient temperature is too low for this refrigeration appliance. If the ambient temperature is too low, the compressor will run less frequently. This may cause the freezer section to become too warm.</p> <ul style="list-style-type: none"> <li>■ See the information in “Installation – Installation site”.</li> <li>■ Increase the ambient temperature.</li> </ul>
<p><b>The compressor runs continuously.</b></p>	<p>This is not a fault. To save energy, the compressor runs at a lower speed, but for longer, when less cooling is required.</p>
<p><b>Food has frozen together.</b></p>	<p>The food packaging was not dry when placed in the freezer.</p> <ul style="list-style-type: none"> <li>■ Use a blunt instrument, e.g. a spoon handle or plastic scraper, to prise it apart carefully.</li> </ul>
<p><b>An alarm sounds.</b></p>	<p>The appliance door has been open for longer than 2 minutes.</p> <ul style="list-style-type: none"> <li>■ Close the appliance door.</li> </ul>
<p><b>No alarm sounds despite the appliance door being open.</b></p>	<p>You have switched off the buzzer.</p> <ul style="list-style-type: none"> <li>■ Switch the buzzer back on using Settings mode .</li> </ul> <p>The Sabbath mode  function is switched on: the temperature display is dark and the  symbol is shown in the display.</p> <ul style="list-style-type: none"> <li>■ You can switch off Sabbath mode at any time (see “Selecting additional settings – Switching Sabbath mode  on or off”).</li> </ul>
<p><b>The appliance door cannot be opened.</b></p>	<p>The Pull2open door assistant is switched on but the refrigeration appliance has a handle-free furniture front.</p> <ul style="list-style-type: none"> <li>■ For handle-free furniture fronts, switch on the Push2open door assistant (see “Selecting additional settings – Switching on the Door assistant ”).</li> </ul>

## Problem solving guide







Problem	Cause and remedy
<b>The appliance door cannot be opened when Sabbath mode  is switched on.</b>	<p>The Push2open door assistant is switched on at the same time as Sabbath mode.</p> <ul style="list-style-type: none"><li>■ When Sabbath mode is switched on, the door assistant is deactivated.</li><li>■ Pull the appliance door open from below or from the side.</li></ul>

# Problem solving guide

## Display warnings

Message	Cause and remedy
<p><b>The warning sounds and the message</b> Freezer temperature too high. Max. temperature °C <b>appears on the display.</b></p>	<p>The temperature in the refrigeration appliance has risen significantly. This could be due to, for example:</p> <ul style="list-style-type: none"> <li>– The appliance door being opened too often, or being left open</li> <li>– A large amount of food being frozen at once</li> <li>– An extended mains outage</li> </ul> <p>■ If you find the alarm disruptive, you can switch it off in advance by touching the <i>OK</i> sensor.</p> <p>The alarm will stop.</p> <p>■ Rectify the cause of the alarm.</p> <p>The alarm will stop and the error message will disappear from the display.</p> <p>The temperature display will show the highest temperature that was reached during the time in which the temperature in the freezer zone rose.</p> <p>■ Depending on the temperature displayed, you should check whether food in the freezer has started to thaw or has defrosted. If it has, it should be used as soon as possible. Defrosted food may only be re-frozen after it has been cooked.</p> <p>■ In the event of a mains outage, check whether there are any ice cubes in the ice cube container and dispose of these. Otherwise, the ice cubes will freeze together and can damage the ice cube container when they expand.</p>
<p><b>The warning sounds and the message</b> Close the door <b>will appear on the display.</b></p>	<p>The appliance door is open.</p> <ul style="list-style-type: none"> <li>■ Close the appliance door.</li> <li>■ If you wish to turn the alarm off early, touch the <i>OK</i> sensor on the display.</li> </ul> <p>The alarm will stop.</p>
<p><b>The temperature display is dark and the  symbol is shown in the display.</b></p>	<p>The Sabbath mode  function is switched on. The interior lighting is switched off and the refrigeration appliance is cooling down.</p> <p>■ You can switch off Sabbath mode at any time (see “Selecting additional settings – Switching Sabbath mode  on or off”).</p>

## Problem solving guide

Message	Cause and remedy
<b>F Please call Miele Service appears on the display and an alarm sounds.</b>	<p>There is a fault.</p> <ul style="list-style-type: none"> <li>■ Make a note of the error message if necessary.</li> <li>■ Call the Miele Customer Service Department.</li> <li>■ To turn the alarm off, touch the  symbol.</li> </ul> <p>The error message will not disappear from the display until the error has been rectified.</p>
	<p>The voltage level is too high/low.</p> <ul style="list-style-type: none"> <li>■ Observe the connection data under “Installation – Electrical connection”.</li> <li>■ Contact the Miele Customer Service Department if necessary.</li> <li>■ To turn the alarm off, touch the  symbol.</li> </ul> <p>The error message will not disappear from the display until the error has been rectified.</p>
<b>The  symbol lights up in the display. The refrigeration appliance does not get cold, although the appliance controls are working.</b>	<p>The Demo mode  is switched on. Demo mode allows the refrigeration appliance to be presented in the showroom without the cooling system being switched on. This setting is not needed for domestic use.</p> <ul style="list-style-type: none"> <li>■ Switch off Demo mode  (see “Selecting additional settings – Switching Demo mode  off”).</li> </ul>

### Problems with the Ice/Water dispenser

Problem	Cause and remedy
<b>The Ice/Water dispenser cannot be switched on.</b>	<p>The refrigeration appliance is not connected to the power supply.</p> <ul style="list-style-type: none"> <li>■ Check that the refrigeration appliance is connected to the electricity supply.</li> </ul>
	<p>The system lock of the Ice/Water dispenser is active (the  sensor control is highlighted in white).</p> <ul style="list-style-type: none"> <li>■ Switch off the system lock (see “Operating the Ice/Water dispenser – Switching the system lock on/off”).</li> </ul>
<b>The Ice/Water dispenser is not immediately ready for operation after having been switched on.</b>	<p>This is not a fault. After the appliance door has opened and closed, it can take several seconds until the Ice/Water dispenser is ready for operation.</p>

## Problem solving guide

---

Problem	Cause and remedy
<b>No ice cubes are dispensed.</b>	<p>The Ice/Water dispenser spout is blocked by clumps of ice.</p> <ul style="list-style-type: none"><li>■ Remove the ice that has clumped together.</li><li>■ Empty the ice cube container at the latest if you have not produced any ice for a week (see “Cleaning and care – Emptying and cleaning the ice cube container”).</li></ul> <p>After the Ice/Water dispenser has been switched on, it can take up to 24 hours until the first serving of ice cubes is ready.</p>
<b>The chilled water from the Ice/Water dispenser does not taste good.</b>	<p>If you dispense chilled water again after a longer period of time, it may be stale.</p> <ul style="list-style-type: none"><li>■ In this case, pour away the first 15 glasses of water.</li></ul>



### Problems with the ice cube maker

Problem	Cause and remedy
<p><b>The ice maker is not producing any ice cubes or no cold water is being dispensed.</b></p>	<p>The refrigeration appliance or the Ice/Water dispenser has not been switched on.</p> <ul style="list-style-type: none"> <li>■ Make sure that the refrigeration appliance is switched on.</li> <li>■ Make sure that the Ice/Water dispenser is switched on.</li> </ul>
	<p>The mains water connection has not been installed.</p> <ul style="list-style-type: none"> <li>■ Make sure that the mains water connection has been installed correctly.</li> </ul>
	<p>The water supply is not open or has not been vented.</p> <ul style="list-style-type: none"> <li>■ Open the water supply.</li> <li>■ Check whether the water supply has been vented.</li> </ul>
	<p>There is a kink in the water hose.</p> <ul style="list-style-type: none"> <li>■ Check the water hose and replace it if necessary.</li> </ul>
	<p>The temperature in the freezer zone is too high.</p> <ul style="list-style-type: none"> <li>■ Set the temperature in the freezer zone lower (see “The correct temperature”).</li> </ul>
	<p>The appliance door has been opened too frequently, causing the compressor to turn on more often and the ice maker has iced up.</p> <ul style="list-style-type: none"> <li>■ Only open the appliance door when necessary and for as short a time as possible.</li> </ul>
	<p>The water pressure is too low.</p> <ul style="list-style-type: none"> <li>■ Check whether the water pressure is between 200 kPa and 800 kPa (2 bar and 8 bar).</li> <li>■ Check whether an incorrect valve has been installed, making the pressure too low.</li> </ul>
	<p>After the Ice/Water dispenser has been switched on, it can take up to 24 hours until the first serving of ice cubes is ready.</p>

## Problem solving guide





Problem	Cause and remedy
<p><b>The ice maker is only producing small ice cubes.</b></p>	<p>Several household appliances connected to the mains water connection are in operation, which has reduced the amount of water being taken in.</p> <ul style="list-style-type: none"> <li>■ Avoid using the dishwasher, washing machine, etc. at the same time.</li> </ul>
	<p>The water filter is clogged.</p> <ul style="list-style-type: none"> <li>■ Check whether the water filter needs to be cleaned.</li> </ul>
	<p>The water connection pressure is too low.</p> <ul style="list-style-type: none"> <li>■ Check that the water connection is between 200 kPa and 800 kPa (2 bar and 8 bar).</li> <li>■ Check whether an incorrect valve has been installed.</li> </ul>
<p><b>The ice maker is producing only a few or deformed ice cubes or only a little cold water is being dispensed.</b></p>	<p>The water filter is clogged.</p> <ul style="list-style-type: none"> <li>■ Check whether the water filter needs to be changed or cleaned.</li> </ul>
	<p>The water pressure is too low.</p> <ul style="list-style-type: none"> <li>■ Check whether the water pressure is between 200 kPa and 800 kPa (2 bar and 8 bar).</li> </ul>
	<p>The temperature in the freezer zone is too high.</p> <ul style="list-style-type: none"> <li>■ Select a lower temperature.</li> </ul>
<p><b>The ice cubes taste or smell odd.</b></p>	<p>The ice cube container is in constant use and needs to be cleaned regularly.</p> <ul style="list-style-type: none"> <li>■ Check whether the ice cube container is dirty and clean it if necessary.</li> </ul>
	<p>The ice cube container is rarely used. Ice cubes that are stored for a long time can absorb the taste and smell of other items.</p> <ul style="list-style-type: none"> <li>■ Empty and clean the ice cube container if you are not going to use it for a long time.</li> </ul>
	<p>Unwrapped food is stored in the freezer zone. Ice can absorb the taste and smell of unwrapped food.</p> <ul style="list-style-type: none"> <li>■ Only store packaged food in the freezer zone.</li> </ul>
	<p>The water filter is dirty.</p> <ul style="list-style-type: none"> <li>■ Check whether the water filter needs to be cleaned.</li> </ul>

## Problem solving guide

Problem	Cause and remedy
<b>Water is flowing out of the refrigeration appliance.</b>	<p>The water inlet is faulty.</p> <ul style="list-style-type: none"><li>■ Close the stopcock immediately.</li><li>■ Check whether the water line is damaged.</li><li>■ Contact the Miele Customer Service Department.</li><li>■ Check whether the water pressure is too high.</li></ul> <p>If the water pressure is too high, this can cause leaks (see “Mains water connection” in “Installation”).</p> <ul style="list-style-type: none"><li>■ Check whether the water pressure is between 200 kPa and 800 kPa (2 bar and 8 bar).</li><li>■ Check whether an incorrect valve has been installed.</li></ul>

## Problem solving guide

### The interior lighting is not working.

Problem	Cause and remedy
<b>The interior lighting is not working.</b>	The refrigeration appliance has not been switched on. ■ Switch the refrigeration appliance on.
	The Sabbath mode function is switched on: the temperature display is dark and the  symbol is shown in the display. ■ You can switch off Sabbath mode at any time via the Settings mode  .
	There is a fault. <div data-bbox="404 528 1038 807" style="border: 1px solid gray; padding: 5px;"><p> Risk of electric shock due to exposed, live electrical components. When removing the lighting cover, there is a risk of coming into contact with live electrical components. Do not remove the lighting cover. The LED lighting may only be repaired or replaced by the Miele Customer Service Department.</p></div>
	<div data-bbox="404 823 1038 1038" style="border: 1px solid gray; padding: 5px;"><p> Risk of injury from LED lighting. This lighting corresponds to risk group RG 2. If the cover is defective, there is a danger of eye injury. If the lighting cover is defective, do not look from a close range directly into the lighting with optical instruments (e.g. magnifying glass or similar).</p></div> ■ Call the Miele Customer Service Department.

Normal noises	What is causing them?
<b>Brrrrr ...</b>	A humming noise is made by the compressor. This noise can get louder for brief periods when the compressor switches on.
<b>Blubb, blubb ...</b>	A gurgling noise can be heard when the refrigerant circulates through the pipes.
<b>Click ...</b>	Clicking sounds occur whenever the thermostat switches the compressor on or off.
<b>Sssrrrrr ...</b>	You can sometimes just hear the sound of the fan inside the appliance.
<b>Crack ...</b>	A cracking sound can be heard when materials expand inside the refrigeration appliance.
Please bear in mind that a certain amount of noise is unavoidable (from the compressor and the refrigerant circulating through the cooling circuit).	

Noises	Cause and remedy
<b>Rattling, vibrating</b>	The refrigeration appliance is uneven. Realign the appliance using a spirit level by raising or lowering the adjustable feet underneath the refrigeration appliance.
	The refrigeration appliance is touching another appliance or piece of furniture. Move it away.
	Drawers, baskets or shelves are jiggling or are stuck. Check all removable items and refit them correctly.
	Bottles or containers are touching. Separate them.

## Service

Information to help you rectify faults yourself and about Miele spare parts can be found at [www.miele.com/service](http://www.miele.com/service).

### Contact in the event of a fault

In the event of a fault which you cannot remedy yourself, please contact your Miele dealer or Miele Customer Service.

You can book a Miele Customer Service call-out online at [www.miele.com/service](http://www.miele.com/service).

Contact information for Miele Customer Service can be found at the end of this document.

Please quote the model identifier and serial number of your appliance (SN) when contacting Miele Customer Service. Both numbers can be found on the data plate inside the refrigeration appliance or, depending on the model, in Settings mode under Information **i**.

The data plate can be found in the interior cabinet of the refrigeration appliance.

### EPREL database

Since 1 March 2021, information on energy labelling and ecodesign requirements has been available in the European Product Database (EPREL). You can find the product database at the following link <https://eprel.ec.europa.eu/>. You will be asked to enter the model identifier.

The model identifier can be found on the data plate inside the refrigeration appliance or, depending on the model, in Settings mode under Information **i**.

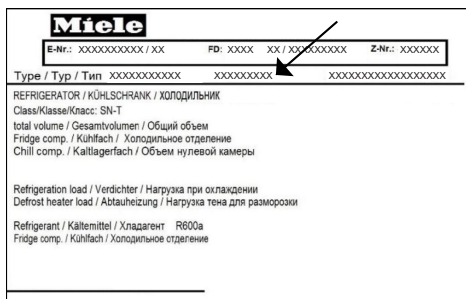

### Warranty

For information on the appliance warranty specific to your country please contact Miele. See back cover for address.

In the UK, your appliance warranty is valid for 2 years from the date of purchase. However, you must activate your cover by calling 0330 160 6640 or registering online at [www.miele.co.uk](http://www.miele.co.uk).

## EU Conformity declaration

---

Miele hereby declares that this freezer complies with Directive 2014/53/EU.

The complete text of the EU declaration of conformity is available from one of the following internet addresses:

- Products, Download from [www.miele.ie](http://www.miele.ie)
- For service, information, operating instructions etc: go to <https://miele.co.uk/manuals> and enter the name of the product or the serial number

Frequency band of the WiFi module	2.4000 GHz – 2.4835 GHz
-----------------------------------	-------------------------

Maximum transmitting power of the WiFi module	< 100 mW
---	----------

# UK Conformity declaration

---

Miele hereby declares that this freezer complies with UK Radio Equipment Regulations 2017, as amended.

The complete text of the UK declaration of conformity is available from one of the following internet addresses:

- Products, Download from [www.miele.co.uk](http://www.miele.co.uk)
- For service, information, operating instructions etc: go to <https://miele.co.uk/manuals> and enter the name of the product or the serial number

Frequency band of the WiFi module	2.4000 GHz – 2.4835 GHz
-----------------------------------	-------------------------

Maximum transmitting power of the WiFi module	< 100 mW
---	----------

This **Statement of Compliance** confirms this Miele product fully complies with the **Product Security and Telecommunications Infrastructure (Security Requirements for Relevant Connectable Products) Regulations 2023**.

- 1) Household Appliance – *Freezer-KI KSDF18EUM, KI KIWD24EUM, KI KSDF30EUM*  
*Refrigerator-KI KSDR30EUM, KI KSDR36EUM*  
*Fridge-freezer-KI KBM30EUM, KI KBM36EUM,*  
*KI KBM36DEUM*  
*Wine unit-KI KSDW24EUM*
- 2) Manufactured by: Miele & Cie KG,  
Carl Miele Street 29, 33332 Gutersloh Germany  
Imported by and contact point: Miele Company Ltd, Fairacres, Marcham Road,  
Abingdon, Oxon, OX14 ITW Great Britain
- 3) The defined support period at the time of first supply is 7 years
- 4) To report vulnerabilities and cybersecurity issues please contact: [psirt@miele.com](mailto:psirt@miele.com)
- 5) Signature 

Name: **Paul Wright**

Company Position: **Head of Technical Management**

Date of signature: **19th March 2024**

Place of signature: **Abingdon, Oxfordshire**



## Copyrights and Licences

---

Miele uses their own and third party software which is not subject to any so-called Open Source Licence for the operation and control of the appliance. This software/ these software components are protected by copyright. The copyright powers of Miele and third parties have to be respected.

Furthermore, this appliance contains software components which are distributed under Open Source licence conditions. Please refer to the document “Open Source Information and Licenses” for the Open Source components contained therein, together with the corresponding copyright notices, copies of the licence terms valid at the time, and any further information. The liability and warranty provisions of the Open Source licence terms and conditions as stated therein apply only in relation to the respective rights holders.

In particular, the appliance contains software components licenced by the copyright holders under the GNU General Public License, Version 2, or the GNU Lesser General Public License, Version 2.1. For a period of at least 3 years from the date of purchase or delivery of the appliance respectively, Miele offers to provide you or third parties with a machine-readable copy of the source code of the Open Source components contained in the appliance and licenced under the terms of the GNU General Public License, Version 2, or the GNU Lesser General Public License, Version 2.1, on a data carrier (CD-ROM, DVD or USB stick). Please contact us via e-mail ([info@miele.com](mailto:info@miele.com)) or the below postal address and state the product name, the serial number and the date of purchase to obtain this source code.

Miele & Cie. KG  
Open Source  
GTZ/TIM  
Carl-Miele-Straße 29  
33332 Gütersloh

Please note the limited warranty in favour of the rights holders under the terms of the GNU General Public License, Version 2, and the GNU Lesser General Public License, Version 2.1:

*This program is distributed in the hope that it will be useful, but WITHOUT ANY WARRANTY, without even the implied warranty of MERCHANTABILITY of FITNESS FOR A PARTICULAR PURPOSE. See the GNU General Public License and GNU Lesser General Public License for more details.*



## United Kingdom

Miele Co. Ltd., Fairacres, Marcham Road, Abingdon, Oxon, OX14 1TW  
Tel: 0330 160 6600, Internet: [www.miele.co.uk](http://www.miele.co.uk), E-mail: [info@miele.co.uk](mailto:info@miele.co.uk)

### Australia

Miele Australia Pty. Ltd.  
ACN 005 635 398  
ABN 96 005 635 398  
Level 4, 141 Camberwell Road  
Hawthorn East, VIC 3123  
Tel: 1300 464 353  
E-mail: [info@miele.com.au](mailto:info@miele.com.au)  
Internet: [www.miele.com.au](http://www.miele.com.au)

### China Mainland

Miele Electrical Appliances Co., Ltd.  
1-3 Floor, No. 82 Shi Men Yi Road  
Jing' an District  
200040 Shanghai, PRC  
Tel: +86 21 6157 3500  
Fax: +86 21 6157 3511  
E-mail: [info@miele.cn](mailto:info@miele.cn)  
Internet: [www.miele.cn](http://www.miele.cn)

### Hong Kong, China

Miele (Hong Kong) Ltd.  
41/F - 4101, Manhattan Place  
23 Wang Tai Road  
Kowloon Bay, Hong Kong  
Tel: (852) 2610 1025  
Fax: (852) 3579 1404  
E-mail:  
[customerservices@miele.com.hk](mailto:customerservices@miele.com.hk)  
Website: [www.miele.hk](http://www.miele.hk)

### India

Miele India Pvt. Ltd.  
1st Floor, Copia Corporate Suites,  
Commercial Plot 9, Mathura Road,  
Jasola, New Delhi - 110025  
E-mail: [customercare@miele.in](mailto:customercare@miele.in)  
Website: [www.miele.in](http://www.miele.in)

### Ireland

Miele Ireland Ltd.  
2024 Bianconi Avenue  
Citywest Business Campus  
Dublin 24  
Tel: (01) 461 07 10  
Fax: (01) 461 07 97  
E-mail: [info@miele.ie](mailto:info@miele.ie)  
Internet: [www.miele.ie](http://www.miele.ie)

### Malaysia

Miele Sdn Bhd  
Suite 12-2, Level 12  
Menara Sapura Kencana  
Petroleum  
Solaris Dutamas No. 1  
Jalan Dutamas 1  
50480 Kuala Lumpur, Malaysia  
Phone: +603-6209-0288  
Fax: +603-6205-3768

### New Zealand

Miele New Zealand Limited  
IRD 98 463 631  
8 College Hill  
Freemans Bay, Auckland 1011  
Tel: 0800 464 353  
E-mail: [customercare@miele.co.nz](mailto:customercare@miele.co.nz)  
Internet: [www.miele.co.nz](http://www.miele.co.nz)

### Singapore

Miele Pte. Ltd.  
29 Media Circle  
#11-04 ALICE@Mediapolis  
Singapore 138565  
Tel: +65 6735 1191  
Fax: +65 6735 1161  
E-mail: [info@miele.com.sg](mailto:info@miele.com.sg)  
Internet: [www.miele.sg](http://www.miele.sg)

### South Africa

Miele (Pty) Ltd.  
63 Peter Place, Bryanston 2194  
P.O. Box 69434, Bryanston 2021  
Tel: (011) 875 9000  
Fax: (011) 875 9035  
E-mail: [info@miele.co.za](mailto:info@miele.co.za)  
Internet: [www.miele.co.za](http://www.miele.co.za)

### Thailand

Miele Appliances Ltd.  
BHIRAJ TOWER at EmQuartier  
43rd Floor Unit 4301-4303  
689 Sukhumvit Road  
North Klongton Sub-District  
Vadhana District  
Bangkok 10110, Thailand

### United Arab Emirates

Miele Appliances Ltd.  
Showroom 1, Eiffel 1 Building  
Sheikh Zayed Road, Umm Al Sheif  
P.O. Box 114782 - Dubai  
Tel. +971 4 3044 999  
Fax. +971 4 3418 852  
800-MIELE (64353)  
E-mail: [info@miele.ae](mailto:info@miele.ae)  
Website: [www.miele.ae](http://www.miele.ae)

**Manufacturer:** Miele & Cie. KG, Carl-Miele-Straße 29, 33332 Gütersloh, Germany

F 2671 Vi

en-GB

M.-Nr. 11 634 040 / 01