

Miele

Operating instructions

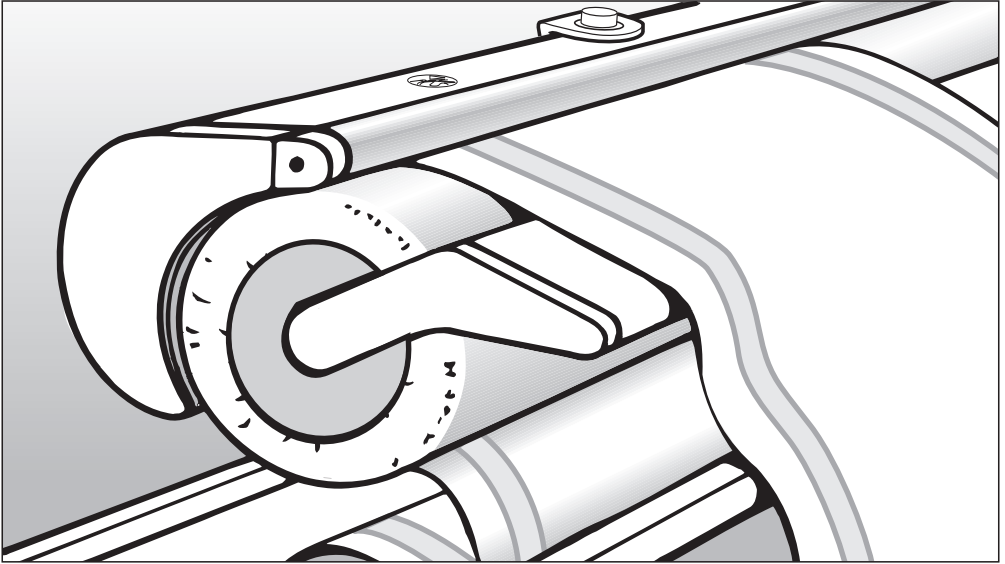

Commercial ironer HM 16-80 D

en-GB

Always read the operating instructions before setting up, installing and commissioning the appliance. This prevents both personal injury and damage to the machine.

M.-Nr. 07 660 640

Contents

Guide to the appliance	4
Warnings and safety notes	6
Caring for the environment	9
Transporting	10
Moving and unfolding	11
Connection	12
Electrical connection	12
Before using for the first time.....	12
Before ironing	14
The ironing station.....	14
Preparing the laundry.....	14
Spraying the laundry with water when ironing without steam.....	14
Further recommendations for the right ironing moisture	14
Stretching and smoothing the laundry	14
Sorting the laundry	15
Using the ironer for the first time	15
Checking the effectiveness of the finger guard.....	15
Steamer	16
Ironing with and without steam	16
Filling the water container.....	16
Emptying the water container	16
Ironing	18
Switching on and off	18
Switching on.....	18
Switching off.....	18
Selecting the ironing temperature (ironing without steam)	18
Selecting the ironing temperature (ironing with steam)	19
Switching the steamer on and off.....	19
Switching on.....	19
Switching off.....	19
Selecting the roller speed	19
Removing the feed board	20
Ironing	20
Ironing.....	20
Steaming.....	20
Raising the heater plate	20
Feeding laundry items.....	20
Airing bar	21
Tips	21

After ironing	21
If the ironer is to be put away:	21
Power failure	21
Ironing practice	23
Towels, tea towels and napkins	23
Tablecloths	23
Sheets and top sheets	23
Duvet covers	23
Pillowcases	24
Shirts	24
Sleeves and cuffs	24
Back of the shirt / shoulder yoke	24
Back section	25
Front sections	26
Collar	26
Nightgowns	26
Pyjamas	26
Overalls, work coats	27
Aprons with straps	27
Steaming trousers	27
Steaming women's skirts	27
Care	28
Cleaning the heater plate	28
Cleaning the casing	28
Cleaning the water container	28
Ironing cloth	28
Replacing the ironing cloth	29
Fault diagnosis	32
Service	34
Contact in the event of a fault	34
Technical data	35

Guide to the appliance

Ironer

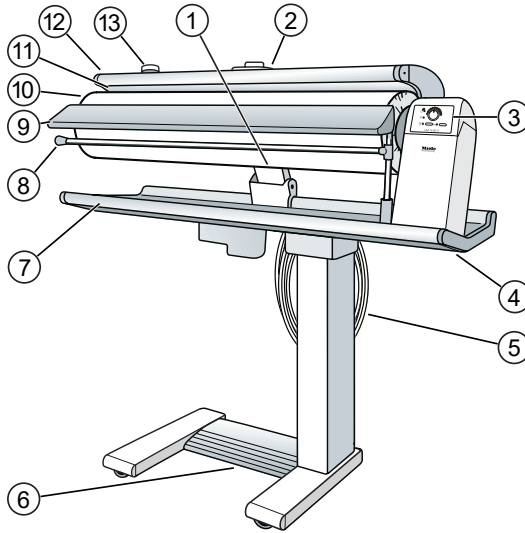

- ① Emergency release
The emergency release manually releases the contact pressure on the heater plate.
- ② Temperature selector
The ironer temperature can be set according to official care labels.
- ③ Control panel
- ④ Release mechanism
- ⑤ Mains connection cable and cable suspension
- ⑥ Foot switch
Sets the roller in motion and the heater plate starts moving.
- ⑦ Laundry table
- ⑧ Airing bar
Allows crease-free cooling and airing of ironed laundry.
- ⑨ Feed board
Makes precise laundry infeed easier.
- ⑩ Roller
- ⑪ Heater plate
- ⑫ Finger guard
- ⑬ Water container cap

Control panel

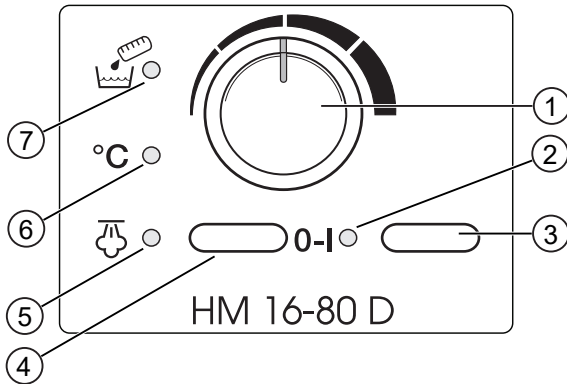

- ① Roller speed selector
- ② O-I indicator light
Lights up when the ironer is switched on.
- ③ O-I switch
Switches the ironer on and off.
- ④ ☁ "Steam" switch
- ⑤ ☁ "Steam" indicator light
- ⑥ °C "Temperature" indicator light
- ⑦ "Water container empty" indicator light

Warnings and safety notes

It is essential to read the operating instructions before using the ironer for the first time.

They contain important information on the safety, use and maintenance of the ironer. This prevents both personal injury and damage to the ironer.

Keep these operating instructions in a safe place and pass them on to any future owner.

Correct application

- ▶ This ironer must only be used for ironing fabrics that are suitable for machine ironing according to the care label and that have been washed with water.
- ▶ This ironer can only be used by people with reduced physical, sensory or mental capabilities, or lack of experience or knowledge, if they are supervised whilst using it or have been shown how to use it in a safe way by an authorised person.

Technical safety

- ▶ Before setting up the ironer, check it for any externally visible damage. Never operate a damaged ironer. A damaged ironer could be dangerous.
- ▶ Make sure that the voltage values (voltage and frequency) of the local mains supply match the voltage specifications on the ironer data plate before connecting the mains connection cable to the socket.

If in doubt, consult a qualified electrician for the voltage values of the local power supply. Connection to a supply voltage other than the one quoted on the data plate can lead to functional faults and damage the ironer.

▶ If the connection cable is damaged it must be replaced with a special cable of the same type (available from Miele). For safety reasons this must only be fitted by a Miele authorised service technician or the Miele service department.

▶ The electrical safety of this ironer can only be guaranteed when correctly earthed. It is essential that this standard safety requirement is observed and regularly tested. If in any doubt, please have the electrical installation inspected by a qualified electrician.

Miele cannot be held liable for the consequences of an inadequate earthing system (e.g. electric shock).

▶ Do not connect the ironer to the mains electricity supply via a multi-socket adapter or an extension lead. These do not guarantee the required safety of the machine (e.g. danger of overheating).

▶ The ironer complies with all relevant current safety requirements. Unauthorised repairs could result in unforeseen dangers for the user, for which the manufacturer cannot accept liability. Repairs should only be carried out by technicians authorised by Miele.

▶ Faulty components must only be replaced by genuine Miele spare parts. Miele can only guarantee the safety standards of the machine when Miele spare parts are used.

▶ The ironer is only electrically disconnected from the power supply when:

- The ironer plug has been removed from the socket or
- The mains circuit breaker is switched off or
- The mains screw-out fuse is removed (in countries where this is applicable)

▶ Do not damage, remove or bypass the safety features or control elements of this ironer.

▶ Only operate the ironer when all removable outer panels are in place so that it is impossible to touch an electrical component or moving part.

▶ The installation of the ironer in non-stationary locations (for example, on ships) may be performed only by specialised companies or specialists if they can guarantee the prerequisites for the safe use of the ironer.

Correct application

▶ Always wear close-fitting clothing when using the ironer. Loose sleeves, apron strings, scarves and ties can be caught by the roller.

▶ Remove any rings, bracelets, necklaces and watches before using the ironer.

▶ When the ironer is heated up, there is an acute danger of burns if you:

- Touch the heater plate
- Reach between the raised heater plate and the roller and step on the foot switch at the same time

▶ Never allow children to play in the immediate vicinity of the ironer. Children must never operate the ironer.

▶ Do not place any items of laundry over the heated heater plate. This poses a fire hazard.

Warnings and safety notes

▶ Use the swing-out airing bar to hang up items of laundry.

The airing bar must only be used for hanging laundry. The airing bar must be swung back in again immediately after use. Do not press on the swing-out airing bar. Otherwise there is a risk of the ironer tipping over due to the lever effect.

▶ Switch off the ironer before unplugging the power plug.

▶ Switch off at the wall socket and withdraw the plug from the socket. Always pull by the plug to withdraw the plug from the socket.

▶ Do not place the mains connection cable over the heated heater plate. This can damage the mains connection cable, resulting in a risk of electric shock. Only use the cable suspension on the back of the ironer to wind up the mains connection cable.

Using accessories

▶ Accessory parts may only be fitted when expressly approved by Miele. If other parts are used, guarantee, warranty and/or product liability claims will be invalidated.

Disposing of the packaging material

The packaging material is used for handling and protects the appliance from transport damage. The packaging material used is selected from materials which are environmentally friendly for disposal and can generally be recycled.

Recycling the packaging material reduces the use of raw materials. Use material-specific collection points for valuable materials and take advantage of return options. Your Miele dealer will take the packaging material away.

Disposing of your old appliance

Electrical and electronic appliances contain many valuable materials. They also contain certain materials, compounds and components which were essential for their correct functioning and safety. These could be hazardous to human health and to the environment if disposed of with household waste or if handled incorrectly. Please do not, therefore, dispose of your old appliance with household waste.



Instead, please make use of officially designated collection and disposal points to dispose of and recycle electrical and electronic appliances in your local community, with your dealer or with Miele, free of charge. By law, you are solely responsible for deleting any personal data from the old appliance prior to disposal. You are legally obliged to remove any old batteries which are not securely enclosed by the appliance and to remove any lamps without destroying them, where this is possible. These must be taken to a suitable collection point where they can be handed in free of charge. Please ensure that your old appliance poses no risk to children while being stored for disposal.

Transporting

Transport safety device

Do not remove the transport safety device until the machine has been set up on the rollers.

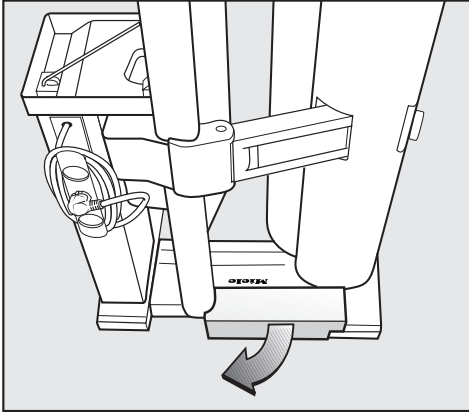

- Pull off the transport safety device.

Keep the transport safety device in a safe place. It must be folded up and re-fitted before transport (e.g. when relocating the machine).

Moving and unfolding

The ironer is equipped with four rollers.

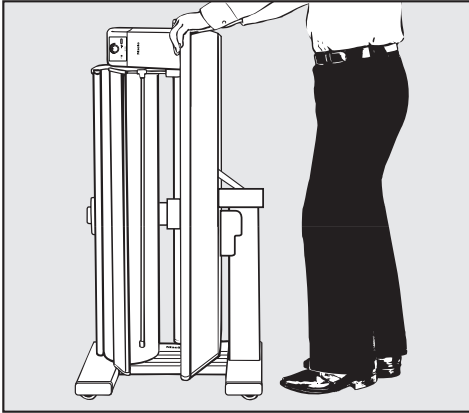

- Hold the ironer by the ironing board and push or pull it in front of you.
- Tilt the ironer slightly to overcome obstacles (e.g. carpet edges or door thresholds) or to steer it.

The ironer can be moved when it is folded or unfolded.

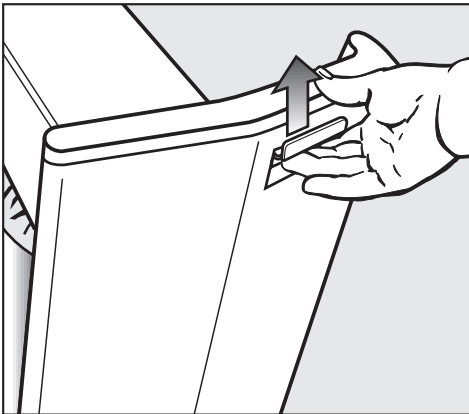

- Pull the release mechanism at the back right under the ironing board while holding the ironing board.

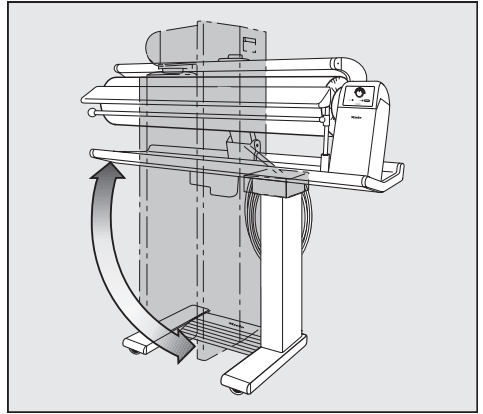

- Swivel the upper part of the ironer into a horizontal or vertical position as far as it will go. Do not release the release mechanism until you have finished swivelling the ironer.
- To prevent water from leaking when folding up and transporting the ironer, always screw the water container cap on tightly.

Connection

Electrical connection

The ironer is equipped for connection to a properly installed earthed socket for AC 220–240 V 50–60 Hz.

The power rating and mains fuse can be found on the data plate.

For increased safety, VDE recommends in its guideline DIN VDE 0100 Part 739 that you should protect the appliance with a suitable residual current device (RCD) with a trip current of 30 mA (DIN VDE 0664). When using the “residual current device” safety feature, only a residual current device that is sensitive to pulse current must be used.

Special regulation for Austria: When using the “residual current device” safety feature, only a residual current device that is sensitive to pulse current must be used.

Connection

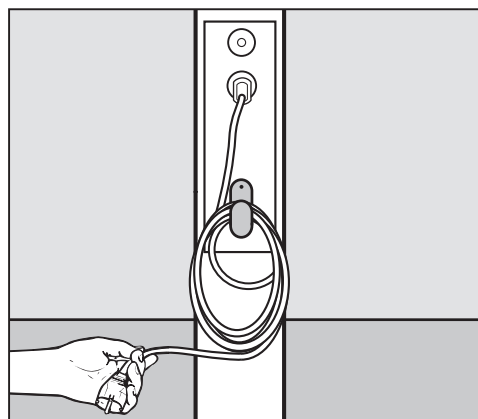

The connection cable is wound up behind the laundry table.

- Unwind the cable.
Do not insert the plug into the socket yet.

Before using for the first time

For transport purposes, the roller is equipped with a film to protect it against dust.

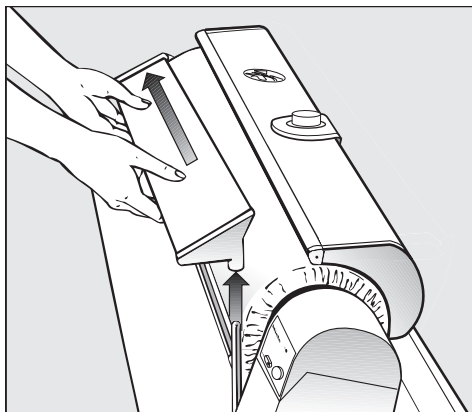

- Remove the feed board. First lift the feed board from the right-hand board holder and then pull it out on the left-hand side of the roller.

As soon as the plug is inserted and the ironer is switched on, the heater plate raises automatically. Then remove the dust protection film from the roller.

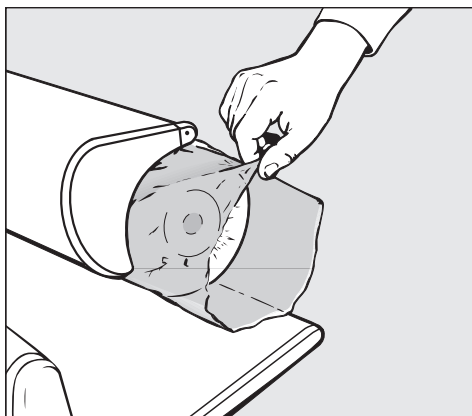

- Remove the dust protection film from the roller.

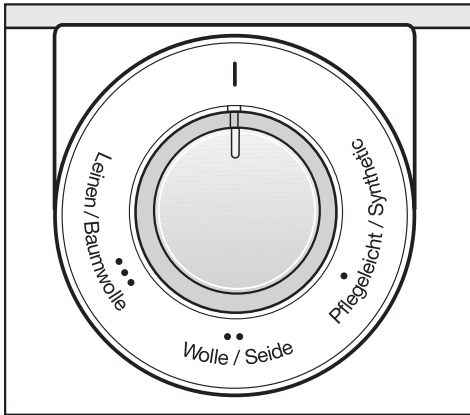

- ◆ Minimum iron/Synthetics
- ◆◆ Woollens/Silks
- ◆◆◆ Linens/Cottons
- Stick the adhesive film included in the accessories around the temperature selector.

Before ironing

The ironing station

You need a height-adjustable chair and a shelf for the ironed laundry.

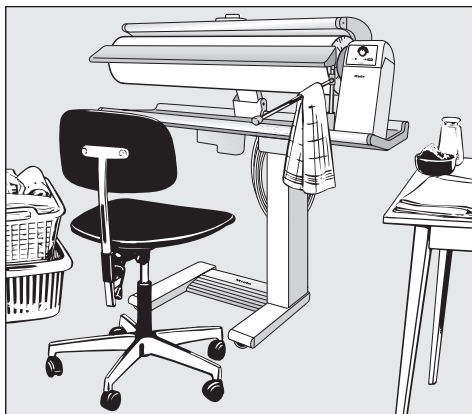

Ensure that the ironer is level so that steam is emitted evenly. Ensure that the ironer is sufficiently stable to prevent it from rolling sideways.

The following should be within easy reach:

- The basket with the prepared laundry on the left of the ironer
- A shelf for the ironed laundry on the right of the ironer

Shirts, overalls, blouses, etc. should be hung on hangers immediately.

Smaller items of laundry can be hung over the swing-out airing bar.

Also provide a container with water to re-moisten the laundry.

Preparing the laundry

Laundry needs to be prepared correctly in order to achieve perfect ironing results.

For this reason, do the following before ironing:

- Spray the laundry with water when ironing without steam

- Stretch and smooth the laundry
- Sort the laundry

Spraying the laundry with water when ironing without steam

Provided the temperature is set correctly, the laundry needs to be sufficiently damp to ensure that it is smooth and dry after an ironing cycle. Therefore, spray the laundry with water as you would when ironing by hand, preferably a few hours in advance so that the moisture is evenly distributed.

If you have access to a tumble dryer, dry the laundry in the Hand iron programme. Use warm water if you don't have much time to prepare and to re-moisten the laundry.

Further recommendations for the right ironing moisture

Material	Moisture
Silks	Wrap in a damp cloth to prevent water stains
Synthetic fibres such as dralon, nylon, perlon, etc.	Slightly damp to dry
Woollens (e.g. trousers)	Steam under a damp cloth
Cottons	Slightly damp
Linen	Relatively damp

Stretching and smoothing the laundry

Stretch the sprayed laundry as normal. Smooth out any ribbons, straps and hems.

Fold large items such as tablecloths, sheets and duvet covers lengthwise and fold them like an accordion: this is the easiest way to iron items like these.

Sorting the laundry

Sort the laundry according to smoothness, shape and sensitivity to heat. This will enable you to iron the items more quickly.

First iron fabrics such as perlon, nylon and artificial silk, which are sensitive to heat. Then, as the temperature rises, iron silk, woollen, cotton and linen items.

Iron starched items last so that any starch residue on the heater plate does not affect the ironing results on other items.

Using the ironer for the first time

An elevation of 2–3 mm can be felt or seen on the roller. This does not affect the ironing process and levels out after approx. 3 hours of ironing.

This ensures that the under-padding is virtually gap-free.

Checking the effectiveness of the finger guard

The finger guard is a safety feature that must be activated before each ironing cycle to check that it is functioning properly.

- With the ironer switched on, step on the foot switch and press it all the way down.
 - The heater plate rests against the rotating roller.

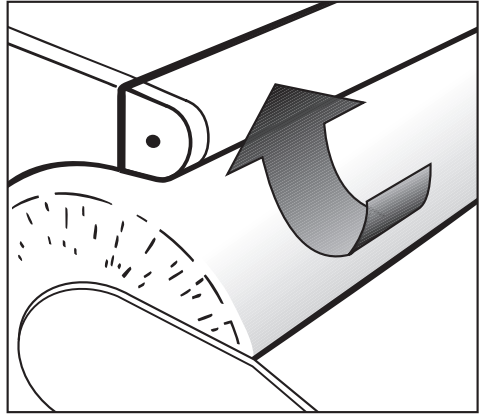

- If you lift the finger guard, the roller comes to a standstill and the heater plate raises.
- Release the finger guard and remove your foot from the foot switch.
- Now press the foot switch all the way down again.
 - The heater plate is engaged and the roller rotates.

Steamer

This ironer is also equipped with a steamer for ironing dry laundry or laundry that is not damp enough.

Ironing with and without steam

If your laundry is already slightly damp, iron without steam. Steam is used to iron dry laundry or laundry that is not dry enough.

Filling the water container

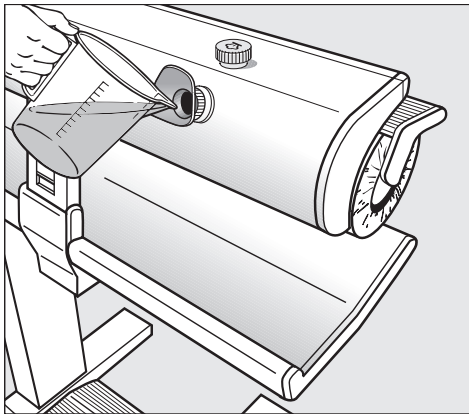

- Before switching on and with the ironer folded open, fill the water container with **tap water** up to the lower edge of the fill spout (approx. 0.8 l). Commercially available ironing water must not be used.
- The pouring aid can be screwed in to make it easier to fill the water container.

In the case of tap water with a water hardness of 17 °dH (3 mmol/l) or more, we recommend mixing with distilled water at a ratio of 1:1.

⚠ Pitting corrosion on the water container
Do not use distilled water only.

- Only fill the water container until the water level reaches the lower edge of the fill spout.
- If the “Water container empty” indicator light lights up red during operation and when the steamer is switched on, you can refill it.
- To prevent water from leaking when folding up the ironer, always screw the water container cap on tightly.

⚠ Steam development
Slowly loosen the cap.

- Wait for the steam to escape from the water container: do not open the cap and top up with water until the steam has stopped escaping.

There may still be residual water in the container. The amount depends on the water hardness and the degree of limescale.

One full water container is enough for about 40 minutes of steam ironing. The time it takes to heat up and develop steam is around 4 minutes. The heating-up time may change as the limescale deposits increase in the water container.

- If you interrupt ironing, we recommend switching off the steam switch.

Emptying the water container

⚠ Risk of burns
Do not empty the water container until the heater plate and the water have cooled down.

The water container must be emptied after ironing. This prevents damage to the water container caused by constituents in the water (e.g. chlorine, limescale, copper).

- Unscrew the cap from the water container fill spout.
- The pouring aid can be screwed in to make it easier to empty the water container.

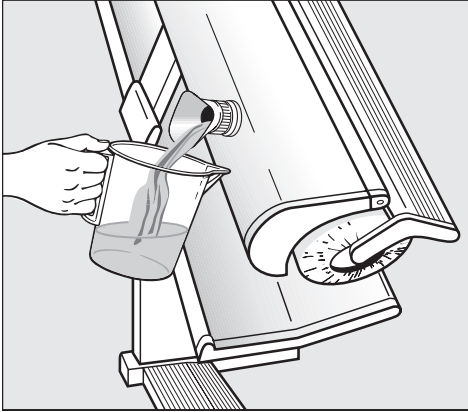

- Slowly tilt the ironer while holding a suitable container (e.g. a measuring cup) under the fill spout.

The water runs out of the appliance.

- Screw the cap back onto the fill spout.

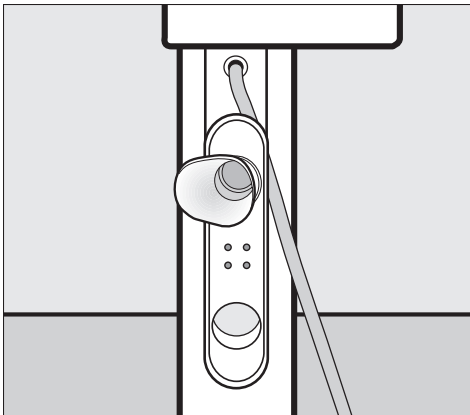

- After use, insert the pouring aid into the receptacle on the cable holder.

Ironing

Switching on and off

The ironer is switched on and off using the **I-O** switch.

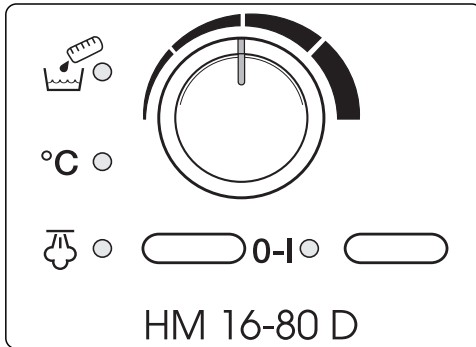

Switching on

- Press the **I-O** switch

The indicator light to the left of the switch lights up.

Switching off

- Press and release the **I-O** switch

The indicator light to the left of the switch goes out.

Selecting the ironing temperature (ironing without steam)

Use the temperature selector to set the ironing temperature.

The temperature settings are indicated by dots around the selector. These dots correspond to the international care symbols used for ironing.

Type of material	Dot symbol	Temperature settings
Minimum iron / Synthetics	•	Low temperature
Woollens / Silks	••	Medium temperature
Linens / Cottons	•••	High temperature
	I	40–60 °C

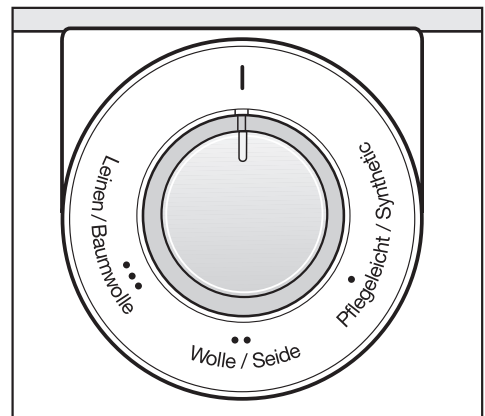

- Set the temperature selector to the temperature you want.

The °C Temperature indicator light lights up for as long as the heater plate is being heated. It goes out as soon as the selected temperature is reached.

When ironing mixed-fibre fabric, select the ironing temperature according to the most sensitive fibre content. For example, items made of polyacrylic and cotton are ironed on the •• Woollens / Silk setting and not on the Cottons setting.

Selecting the ironing temperature (ironing with steam)

- Set the temperature selector to ♦♦♦ Cottons/Linens (high temperature).

It is not possible to iron with steam when the temperature selector is set to ♦ and ♦♦.

Switching the steamer on and off

Use the temperature regulator to select temperature setting ♦♦♦ before switching on the steamer.

The steamer is switched on and off using the “Steam” switch.

Switching on

- Press the “Steam” switch.

When the required heater plate temperature is reached, the indicator light next to the switch lights up.

If the water container becomes empty during operation, the “Steam” indicator light goes out and the “Water container empty” indicator light lights up red.

Switching off

- Press and release the switch.

The indicator light next to the switch goes out.

Selecting the roller speed

The roller speed can be set from a low speed (approx. 2 m/min) to a high speed (approx. 4.5 m/min) in five stages.

A low roller speed makes it easier to iron intricately shaped items, such as shirts or blouses. Reducing the roller speed is

also recommended for items of laundry that are ironed in several layers. One or two cycles are often enough to get the laundry smooth and dry.

Thinner, single-layer items such as napkins or tea towels can be ironed at a higher speed.

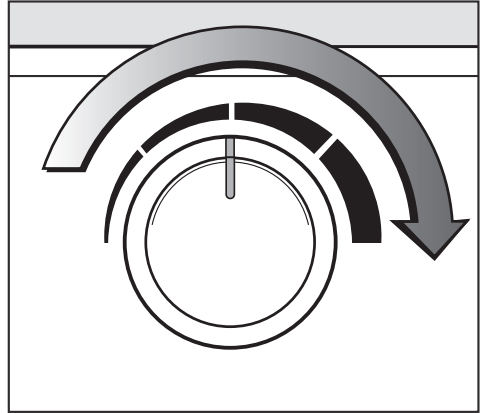

- Set the roller speed selector to the desired speed.

Ironing

Removing the feed board

The feed board can also be removed for ironing items requiring a specific shape, such as round women's skirts.

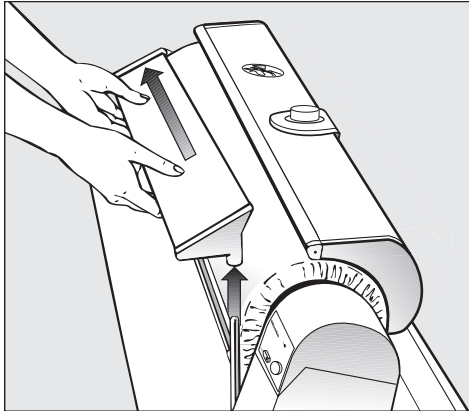

- First lift the feed board from the right-hand holder and then pull it outwards on the left-hand side of the roller.

Ironing

Use the foot switch to control the ironing process. It has three switch positions:

- Raising
- Steaming
- Ironing

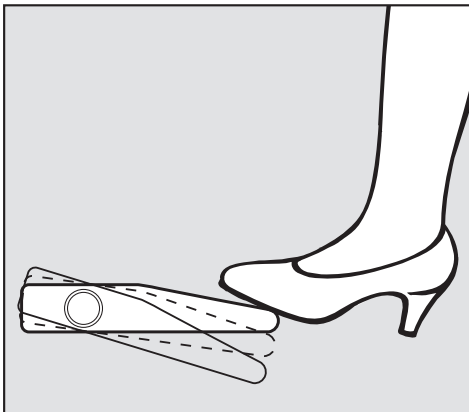

Ironing

- Press the foot switch all the way down.

 Risk of burning and crushing
Do not reach into the gap between the heater plate and roller.

Steaming

- First press the foot switch all the way down, then lift your foot slightly. The roller stops when the heater plate is engaged.

Raising the heater plate

- Remove your foot from the foot switch

Feeding laundry items

- Align the item of laundry on the feed board so that it is straight and smooth.

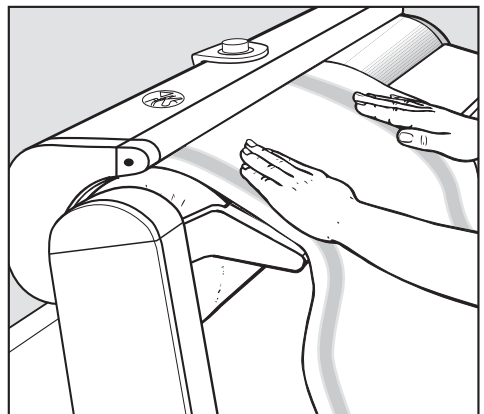

- Then turn the roller with the item in your hand until the beginning of the item is caught by the heater plate.
- Following this, step on the foot switch.

Airing bar

Ironed laundry can be placed over the swing-out airing bar to prevent creasing.

Do not press on the airing bar while it is extended as there is a risk of the ironer tipping over.

Tips

If creases form when the item of laundry is fed in:

Interrupt the ironing process, pull the item back a little and smooth it out. If necessary, moisten with a damp sponge or cloth.

If possible, always use the entire roller width to ensure that the roller padding surface remains smooth.

For small items such as napkins, alternate between the right and left-hand sides of the roller.

Iron fabrics with buttons so that the buttons are facing the roller and can press into the soft roller padding during ironing.

Place a cloth over zips, metal buttons and metal hooks before ironing to protect the heater plate.

To protect the heater plate, do not iron buttons which are not resistant to heat or which rise up significantly from the item (e.g. ball-shaped buttons).

When you have almost finished ironing, you can set the temperature selector to I and then use the residual heat to iron small items.

After ironing

- Switch off the iron.
- Switch off the “Steam” switch.
- Set the temperature selector to I.
- Disconnect the plug from the mains socket.

If the ironer is to be put away:

- Leave the heater plate to cool.
- Empty the water container
- Fold up the ironer.
- Wind up the mains connection cable
- Put on the cover.

 Frozen water can cause damage to the water container and steam hose.

Do not place the ironer in a room where there is a risk of frost.

Power failure

Laundry item is scorched

If the power fails during ironing, the heater plate remains engaged on the roller. The item is held in place and there is a risk of it scorching.

Activate the emergency release.

Ironing

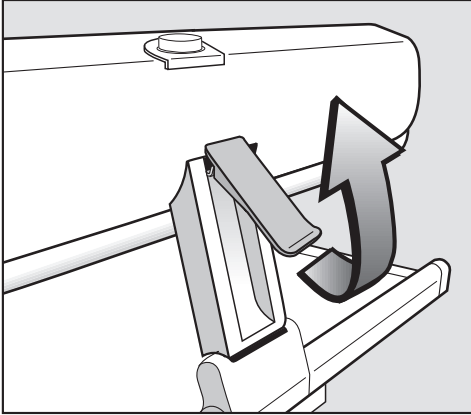

- Pull the emergency release upwards.

The contact pressure is released and the item of laundry can then be removed.

When the power is restored (the indicator light in the power switch lights up), press the emergency release downwards. You can then continue ironing as normal.

Please consider the information on ironing practice to be a list of suggested options. As you gain more ironing experience, you will undoubtedly find out which options suit you better.

Towels, tea towels and napkins

Align the items on the feed board so that the fabric is straight, does not warp and can be folded easily.

Feed in the handkerchiefs and napkins diagonally.

Use the entire roller width.

Tablecloths

Tablecloths will not crease if the centre section is ironed first.

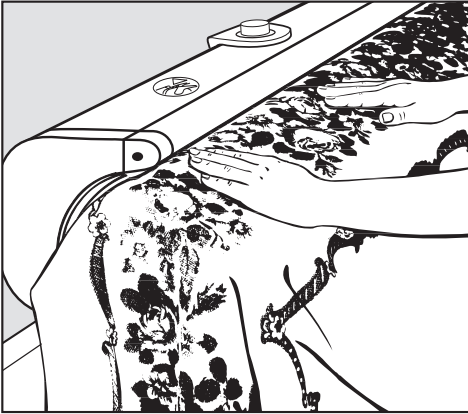

- Lay the tablecloth across the feed board with the ends hanging over the left and right-hand sides.
- Fold widthways.

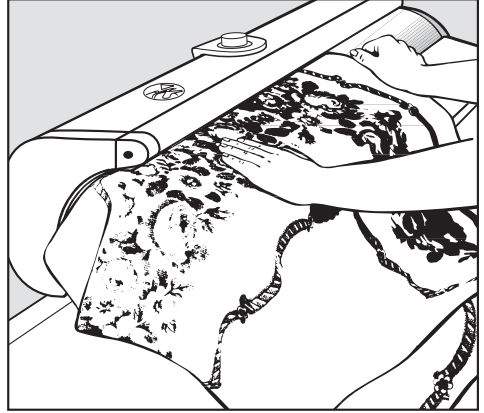

- Iron the unironed section of the tablecloth – on the left side of the roller – on both sides. Allow the ironed centre section to hang over the left-hand roller end to prevent it from creasing.

Sheets and top sheets

Iron sheets like tablecloths – or, if you don't mind iron creases, fold the sheets lengthwise and iron them.

Iron embellishments and embroidery on top sheets first on the front side, then on the back; this will make them look better.

Duvet covers

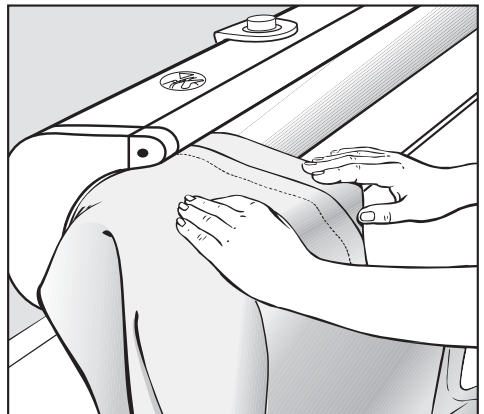

Ironing practice

- First iron the closed buttonhole placket on the left end of the roller. Ensure the buttons are facing the roller.

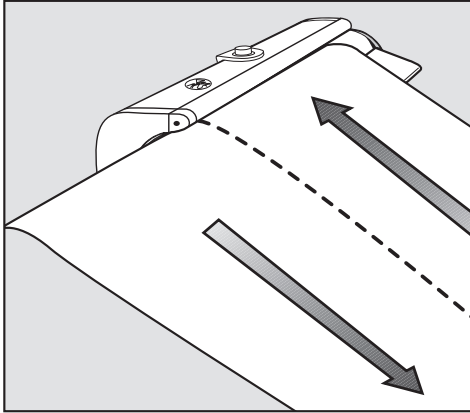

- Iron the duvet cover in 2 lengthwise strips.

Pillowcases

- First iron the closed buttonhole placket (as with duvet covers). Then iron the entire pillowcase on both sides.

If the buttons are facing the heater plate, do not iron the buttons.

Shirts

Iron shirts without the feed board. Ironing sequence:

- Sleeves and cuffs
- Back section
- Front sections
- Collar

Sleeves and cuffs

- Smooth the sleeves and place them diagonally on the roller. Do not iron the cuffs for now.

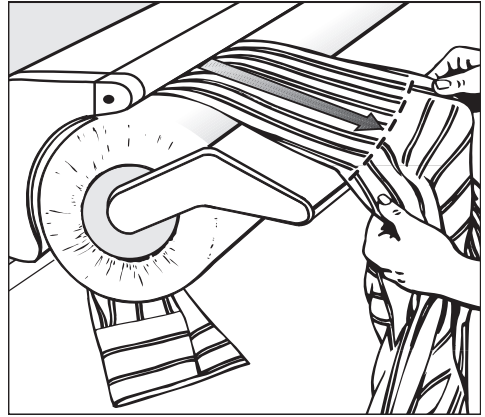

- Iron the sleeves from the cuff seam to the armhole.

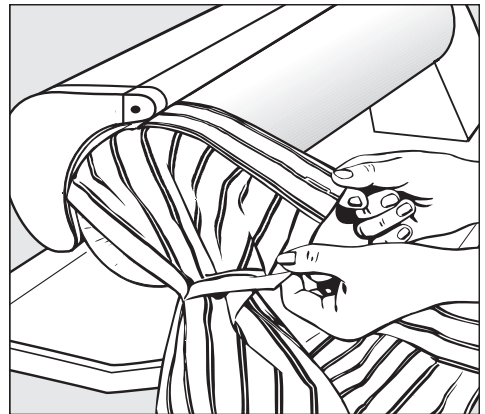

- Iron the cuffs on both sides on the left edge of the roller. Then fold and iron the double cuffs (buttonhole to buttonhole).

Back of the shirt / shoulder yoke

For shirts with a shoulder yoke:

- Fold the yoke along the back seam.

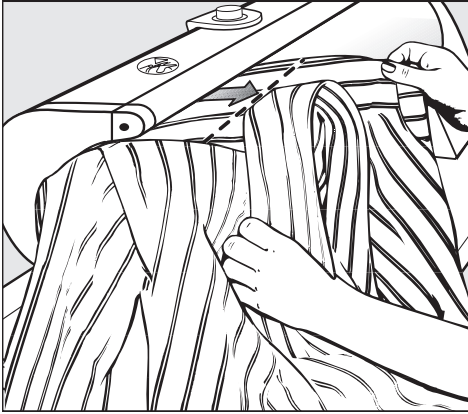

- Lay the shirt diagonally on the roller and iron from the left shoulder seam to the collar.

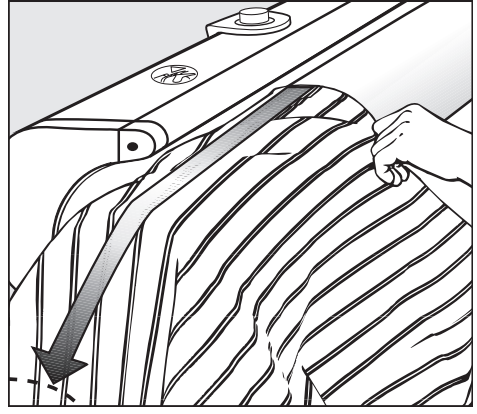

- Pull the shirt, right side of the fabric up, onto the roller up to the yoke seam (or up to the collar seam in the case of shirts without a yoke) and smooth the back.

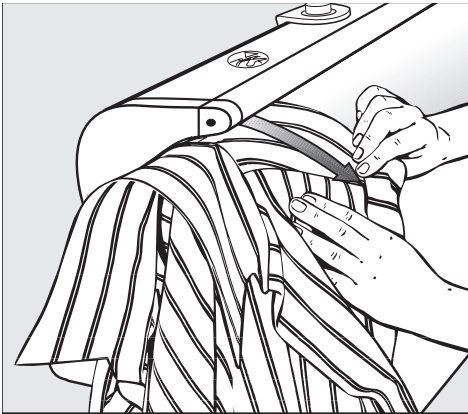

- Then turn the shirt inside out and iron past the collar to the right shoulder seam.

Back section

Iron the back in two sections, approximately from the centre of the back to the side seam.

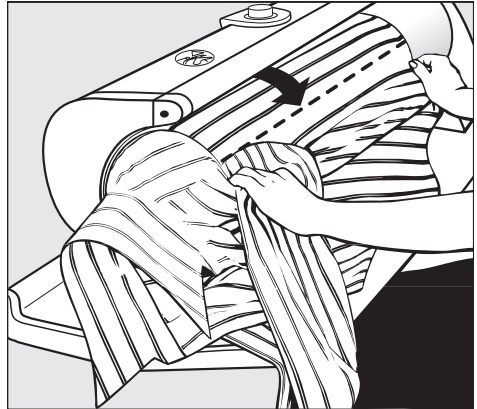

- Iron from the centre of the back to the sleeve seam. Iron the strip that has not been fed into the roller, up to the side seam, together with the front section.

Iron the second section of the back in the same way as the first, but inside out.

- Remove the shirt from the roller, turn it over and place it back on the roller inside out.

Ironing practice

- Iron the back section that has not yet been ironed.

Front sections

Iron the front sections and the unironed back section on the left side of the roller, starting from the bottom hem and moving up to the armhole.

- Start with the left front section!

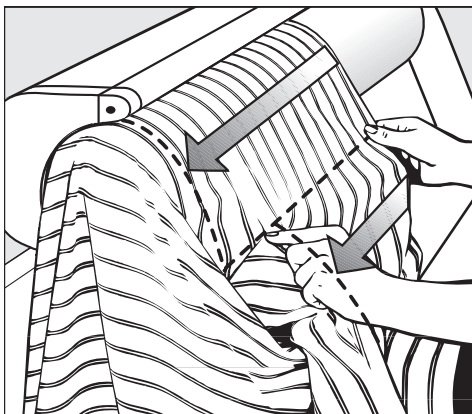

- Remove the shirt and iron past the armhole to the collar.
- Iron the right front section in the same way (but inside out).

Collar

Iron the collar on both sides at the left end of the roller. If the button is facing the heater plate, do not iron the button.

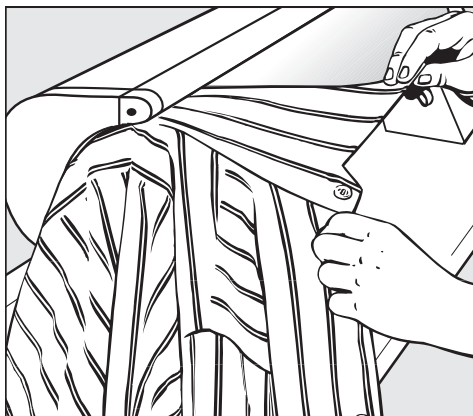

- Then fold the collar over and iron horizontally if necessary.

Nightgowns

Iron the sleeves, yoke and back of the closed nightgown in the same way as you would iron a shirt. Ironing the front:

- Pull the nightgown onto the roller until the sleeves and chest section hang over the left side of the roller.
- Starting from the left side seam, iron round to the right side seam. Move the nightgown back and forth in order to engage the chest section as well, create a centre pleat if necessary, and iron together with the button placket.
- If there is a collar, iron it in the same way as a shirt collar.

Pyjamas

Iron pyjama tops in the same way as you would iron a shirt. Iron the legs of the trousers first, one at a time, on the left-hand side of the roller.

- Iron one leg on the front and the other on the back.
- First iron the leg from the cuff to the gusset.

- Then iron out to the centre seam and continue ironing to the waistband. Pull the elastic waistband tight.

Overalls, work coats

- Iron overalls and work coats in the same way as you would iron a shirt.

Aprons with straps

- Iron the straps side by side up to the bib and over the bib up to the waistband.
- Then iron the apron either in strips up to the waistband or in a transverse direction. Allow the bib to hang over the left-hand end of the roller.

Steaming trousers

- Place each trouser leg individually on the roller. Allow the upper section to hang over the left-hand side of the roller.

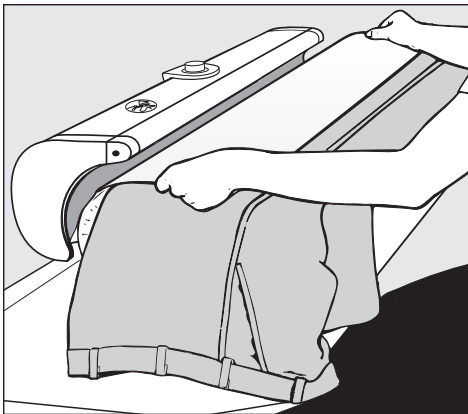

- Place a damp cloth on the trouser leg and turn the roller by hand until the section of the trousers to be steamed is covered by the heater plate.
- Working in this way, steam both sides of each crease individually.

Steaming women's skirts

Do not use the feed board; let the roller rotate freely.

- Pull the skirt over the roller from the free roller end up to the skirt waistband.
- Apply a damp cloth.
- Iron the skirt or pleats section by section.

Care

Before cleaning, switch off at the socket and pull out the plug.

Cleaning the heater plate

If there are limescale deposits or starch residues on the heater plate, these can be removed with commercially available detergents or cleaning agents. Carry out cleaning when the heater plate is cold. Release the emergency release to make the process easier.

Do not use coarse-grained scouring agents.

Cleaning the casing

Depending on the level of soiling, use a dry or damp cloth to wipe the casing.

Do not use coarse-grained scouring agents.

Cleaning the water container

Limescale deposits in the water container are caused by hard water and may be identifiable from small amounts of water escaping from the steam nozzle. These limescale deposits must be removed by rinsing the water container with tap water.

Depending on the hardness of the tap water used, the water container must be rinsed with mains water after the water container has been filled 3 to 10 times. Stubborn limescale can be removed using commercially available descalers.

- Disconnect the plug from the mains socket.

 Risk of burns!

Only rinse out the water container when the machine is cold!

- Fill the water container halfway (0.4 l) and seal it.
- Roll the appliance forwards and backwards several times using a jerky motion.
- To avoid damaging the laundry, rinse thoroughly twice afterwards with tap water.

For information on filling and emptying the water container, see “Steamer”.

Ironing cloth

The ironing cloth consists of aramid needle fibre with 2 % stainless steel fibres.

Slight browning of the ironing cloth is normal over time. However, if the cloth becomes unsightly, it is easy to replace.

Ironing cloths can be purchased from Miele Customer Service.

Replacing the ironing cloth

Replace the ironing cloth only when the heater plate is cold.

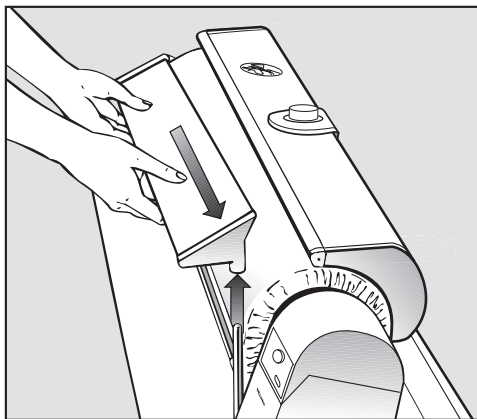

To replace the ironing cloth, remove the feed board.

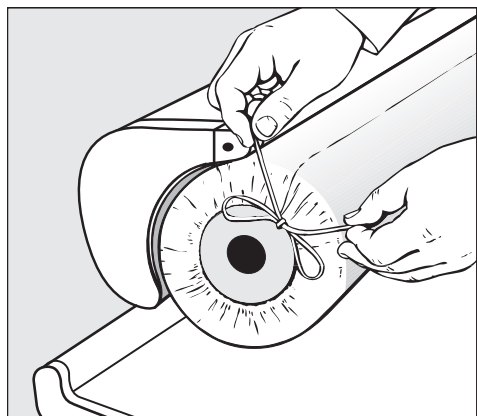

- Loosen the ties on the left and right sides of the roller.

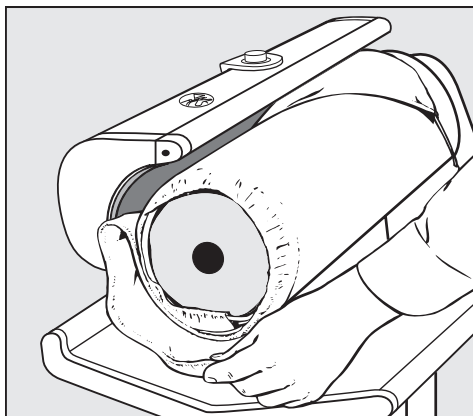

- Unwind the ironing cloth.

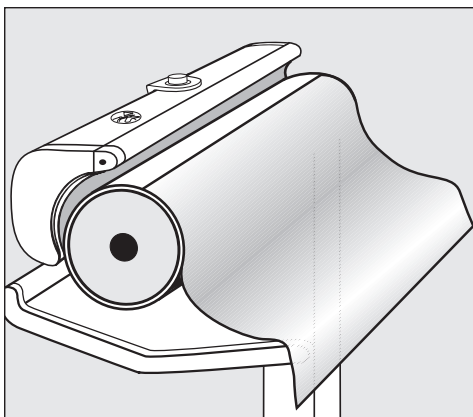

- Completely unwind the cotton cloth attached to the roller and let it hang down evenly.

Care

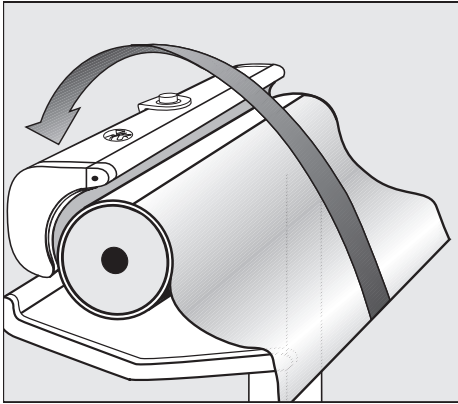

- Grasp the cotton cloth on both sides, pull it tight and place it over the heater plate.

The seam for attaching the cotton cloth is now at the top.

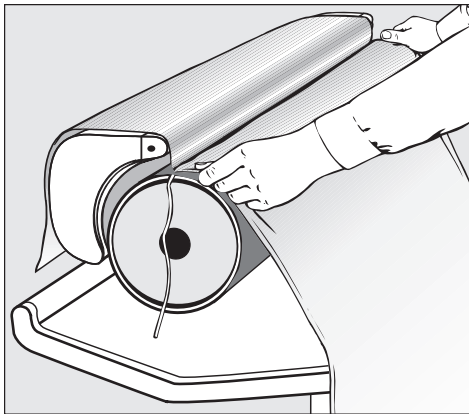

- Place the new ironing cloth with the cut edge in the gap (ties on the outside, lapped seams on the inside) and smooth it out.

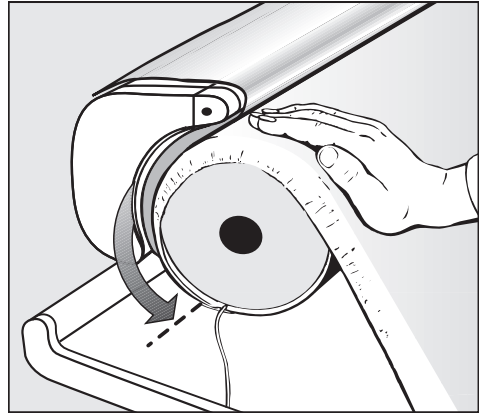

- Rotate the roller by hand in the direction of the iron until the seam is at the bottom; see arrow.
- Switch on the ironer.

⚠ When the ironer is switched on, the heater plate is heated immediately. Always set the temperature regulator to I.

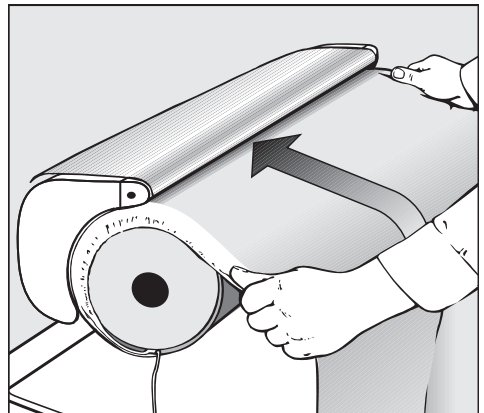

- Press the foot switch and “iron” the ironing cloth into place until it is smooth.

Make sure that the ties are not wrapped around it during this process.

- After the roller has rotated a few times and the ironing cloth end is exactly under the heater plate, switch off the ironer by pressing the foot switch.

The heater plate remains engaged, holding the ironing cloth in place as well.

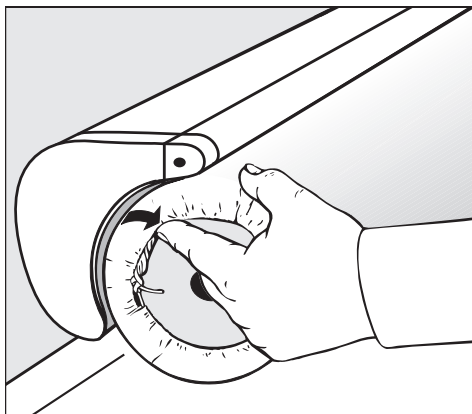

- Tighten the ties on the left and right sides of the roller, knot them and tuck them under the ironing cloth.
- Refit the feed board.
- Switch on the ironer – the heater plate raises.

Fault diagnosis

The majority of faults and problems that arise during day-to-day use can be remedied without external assistance. You can save time and money in many cases, as you do not need to call Miele Customer Service.

The following table is intended to help you to find the cause of a malfunction or fault and correct it. You should, however, note the following:



Repairs by unqualified persons can cause considerable danger to users. Repair work to electrical appliances should only be carried out by an authorised technician.

Fault diagnosis

Problem	Possible cause	Remedy
The ironer cannot be operated.	There is no mains power to the iron.	Check whether the power plug is inserted and whether the on-site circuit breaker is working.
Poor laundry feed.	Soiled ironing cloth.	Washing the ironing cloth at 60 °C.
Poor laundry feed.	Limescale or starch residues on the heater plate.	Clean the residues with commercially available detergents and cleaning agents.
Pleating (crease development).	The heater plate is soiled (limescale).	Clean the heater plate with commercially available detergents and cleaning agents.
Heavily soiled ironing cloth.	Deposits	Washing the ironing cloth at 60 °C.
No contact pressure.	Emergency release activated.	Press the emergency release downwards (see also "Power failure").
There is no steam. The "Steam" indicator light goes out during ironing.	The heater plate temperature is too low for steam ironing.	Set the temperature regulator to ♦♦♦ and wait for the indicator light to light up.
There is no steam. The "Steam" indicator light goes out and the "Water container empty" indicator light lights up red.	The water container is empty.	Fill the water container.
The steam jets are spitting.	Pure tap water was not used.	Empty the steam container, rinse and refill with tap water, see "Care".
Small amount of water coming out of the steam jet.	Limescale deposits in the water container due to hard water.	These limescale deposits must be removed by rinsing the water container with tap water, see "Care".

Service

Information to help you rectify faults yourself and about Miele spare parts can be found at www.miele.com/service.

⑤ Power rating

The wiring diagram is located inside the ironing board at the front right behind the plastic cover.

Contact in the event of a fault





In the event of any faults which you cannot remedy yourself, please contact your Miele dealer or the Miele Customer Service Department.

You can book a Miele Customer Service Department call-out online at www.miele.com/service.

Contact information for the Miele Customer Service Department can be found at the end of this document.

Please quote the model identifier and serial number of your appliance (Fabr./SN/Nr.) when contacting the Miele Customer Service Department. This information can be found on the data plate.

Please note that telephone calls may be monitored and recorded for training purposes and that a call-out charge will be applied to service visits where the problem could have been resolved as described in this booklet.

IBN	Typ	①
	Fabr.Nr.	②
	Art.Nr.	
	M.-Nr.	
		③
		
		④
	Total	⑤
		
		

- ① Model
- ② Serial number
- ③ Voltage/frequency
- ④ Mains fuse (on site)

Technical data

Height	95.9 (folded 105.2) cm
Width	98.5 (folded 50) cm
Depth	38 cm
Weight	Approx. 39 kg
Max. floor load	382 Newtons
Water container capacity	0.5 l
Supply voltage	See data plate
Rated load	See data plate
Fuse rating	See data plate
Test certifications awarded	VDE, radio and television suppressed

United Kingdom

Miele Co. Ltd., Fairacres, Marcham Road
Abingdon, Oxon, OX14 1TW
Professional Sales, Tel: 0845 365 6608
E-mail: professional@miele.co.uk
Internet: www.miele.co.uk/professional

Australia

Miele Australia Pty. Ltd.
ACN 005 635 398, ABN 96 005 635 398
Level 4, 141 Camberwell Road, Hawthorn East, VIC 3123
Tel: 1300 731 411
Internet: www.miele.com.au/professional
E-mail: professional.sales@miele.com.au

China Mainland

Miele Electrical Appliances Co., Ltd.
1-3 Floor, No. 82 Shi Men Yi Road
Jing' an District, 200040 Shanghai, PRC
Tel: +86 21 6157 3500, Fax: +86 21 6157 3511
E-mail: info@miele.cn, Internet: www.miele.cn

Hong Kong, China

Miele (Hong Kong) Ltd.
41/F - 4101, Manhattan Place
23 Wang Tai Road, Kowloon Bay, Hong Kong
Tel: (852) 2610 1025, Fax: (852) 3579 1404
Email: customerservices@miele.com.hk
Website: www.miele.hk

India

Miele India Pvt. Ltd.
1st Floor, Copia Corporate Suites,
Commercial Plot 9, Mathura Road, Jasola,
New Delhi - 110025
E-mail: customercare@miele.in, Website: www.miele.in

Ireland

Miele Ireland Ltd.
2024 Bianconi Ave., Citywest Business Campus,
Dublin 24
Tel: (01) 461 07 10, Fax: (01) 461 07 97
E-Mail: info@miele.ie, Internet: www.miele.ie

Malaysia

Miele Sdn Bhd
Suite 12-2, Level 12
Menara Sapura Kencana Petroleum
Solaris Dutamas No. 1, Jalan Dutamas 1
50480 Kuala Lumpur, Malaysia
Phone: +603-6209-0288
Fax: +603-6205-3768

New Zealand

Miele New Zealand Limited
IRD 98 463 631
8 College Hill
Freemans Bay, Auckland 1011, NZ
Tel: 0800 464 353
Internet: www.miele.com.au/professional
E-mail: professional.sales@miele.com.au

Singapore

Miele Pte. Ltd.
29 Media Circle, #11-04 ALICE@Mediapolis
Singapore 138565
Tel: +65 6735 1191, Fax: +65 6735 1161
E-Mail: info@miele.com.sg
Internet: www.miele.sg

South Africa

Miele (Pty) Ltd
63 Peter Place, Bryanston 2194
P.O. Box 69434, Bryanston 2021
Tel: (011) 875 9000, Fax: (011) 875 9035
E-mail: info@miele.co.za
Internet: www.miele.co.za

United Arab Emirates

Miele Appliances Ltd.
Showroom 1, Eiffel 1 Building
Sheikh Zayed Road, Umm Al Sheif
P.O. Box 114782 - Dubai
Tel. +971 4 3044 999, Fax. +971 4 3418 852
800-MIELE (64353)
E-Mail: info@miele.ae
Website: www.miele.ae



Manufacturer: Miele & Cie. KG, Carl-Miele-Straße 29, 33332 Gütersloh, Germany