

Operating and installation instructions Gas hobs

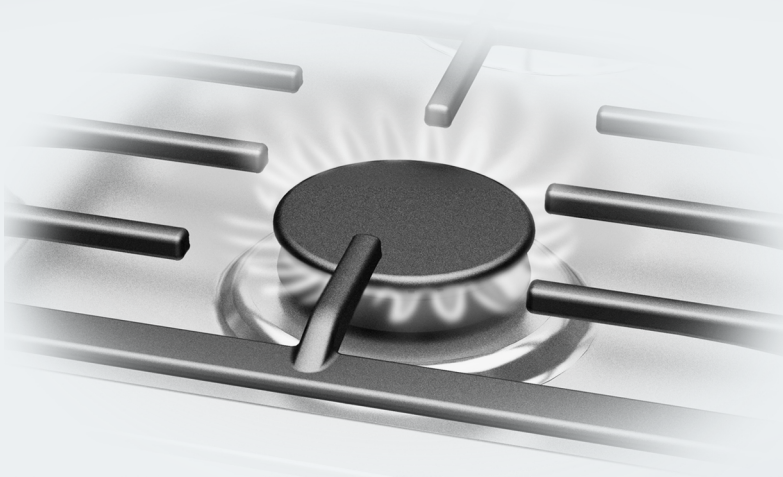

To avoid the risk of accidents or damage to the appliance it is **essential** to read these instructions before it is installed and used for the first time.

This hob can be used in countries other than those specified on the appliance and in these operating and installation instructions. It is, however, set up for connection to the gas and electricity supplies in the countries specified. For trouble-free operation of the appliance, it is best to use it in the countries specified for use.

For use in other countries, please contact Miele in your country.

Safety precautions to take if you smell gas

- Turn off the gas emergency control valve immediately.
This is usually located near the gas meter.
- Eliminate all sources of ignition in a safe manner.
Do not smoke, light cigarette lighters or matches.
- Do not operate electrical lights or switches, i.e. do not switch them „On“ or „Off“.
- Open all doors and windows to ventilate the area.
- If the smell of gas persists, evacuate the building.

Contents

Warning and Safety instructions	6
Caring for the environment	16
Guide to the appliance	17
Hob	17
Control knobs	18
Burner	19
Accessories supplied	20
Before using for the first time	21
Cleaning the hob for the first time	21
Switching on the hob for the first time	21
Pans	22
Tips on saving energy	24
Operation	25
Switching on	25
Adjusting the flame	26
Switching off	26
Safety features	27
Thermo-electric flame failure monitor	27
Cleaning and care	28
Ceramic surface	29
Pan supports	30
Control knobs	30
Burner	30
Problem solving guide	32
Optional accessories	34
After sales service	35
Contact in the event of a fault	35
Data plate	35
Guarantee	35
Installation	36
Safety instructions for installation	36
Safety distances	37
Installation notes	40
Building-in dimensions	41

Contents

Installation	42
Gas connection	44
Burner ratings	47
Electrical connection	48
Converting to another gas type	50
Jet table.....	50
Changing the jets	51
Changing the main jets.....	51
Changing the small jets	52
Functional check	53

Warning and Safety instructions

This hob complies with all relevant local and national safety requirements. Inappropriate use can, however, lead to personal injury and material damage.

Read the operating and installation instructions carefully before using the hob. They contain important information on safety, installation, use and maintenance. This prevents both personal injury and damage to the hob.

Miele expressly and strongly advises that you read and follow the instructions in the chapter on installing the hob as well as the safety instructions and warnings.

Miele cannot be held liable for injury or damage caused by non-compliance with these instructions.

Keep these instructions in a safe place and pass them on to any future owner.

Correct application

- ▶ This hob is intended for domestic use and use in other similar environments.
- ▶ This hob is not intended for outdoor use.
- ▶ It is intended for domestic use only to cook food and keep it warm. Any other use is not supported by the manufacturer and could be dangerous.
- ▶ This hob is not intended for use by people with reduced physical, sensory or mental capabilities or lack of experience and knowledge, unless they have been given supervision and instruction concerning its use by a person responsible for their safety. They may only use the hob unsupervised if they have been shown how to use it in a safe way. They must be able to recognise and understand the dangers of misuse.

Warning and Safety instructions

Safety with children

- ▶ Children under 8 years of age must be kept away from the hob unless they are constantly supervised.
- ▶ Children over 8 years of age may use the hob without supervision if its operation has been clearly explained to them and they are able to use it safely. Children must be able to understand and recognise the possible dangers caused by incorrect operation.
- ▶ Children must not be allowed to clean the hob unsupervised.
- ▶ Please supervise children in the vicinity of the hob and do not let them play with it.
- ▶ The hob gets hot when in use and remains hot for a while after being switched off. Keep children well away from the hob until it has cooled down and there is no danger of burning.
- ▶ Danger of burning! Do not store anything which might arouse a child's interest in storage areas above or behind the hob. Otherwise they could be tempted into climbing onto the appliance with the risk of burning themselves.
- ▶ Risk of burning and scalding. Place pots and pans on the cooking zone in such a way that children cannot pull them down and burn themselves.
- ▶ Danger of suffocation! Whilst playing, children may become entangled in packaging material (such as plastic wrapping) or pull it over their head with the risk of suffocation. Keep packaging material away from children.

Technical safety

- ▶ Unauthorised installation, maintenance and repairs can cause considerable danger for the user. Installation, maintenance and repairs must only be carried out by a Miele authorised technician.
- ▶ Damage to the hob can compromise your safety. Check the hob for visible signs of damage. Do not use the hob if it is damaged.
- ▶ Reliable and safe operation of this hob can only be assured if it has been connected to the mains electricity supply.
- ▶ The electrical safety of this hob can only be guaranteed when correctly earthed. It is essential that this standard safety requirement is met. If in any doubt please have the electrical installation tested by a registered electrical worker.
- ▶ To avoid the risk of damage to the hob, make sure that the connection data on the data plate (voltage and frequency) match the mains electricity supply before connecting it to the mains. Consult a registered electrical worker if in doubt.
- ▶ Do not connect the hob to the mains electrical supply by a multi-socket adapter or extension lead. These are a fire hazard and do not guarantee the required safety of the appliance.
- ▶ For safety reasons, this hob may only be used after it has been built in.
- ▶ This hob must not be used in a non-stationary location (e.g. on a ship).
- ▶ Never open the casing of the hob.
Touching or tampering with electrical connections or components and mechanical parts is highly dangerous to the user and can cause operational faults.
- ▶ While the hob is under warranty, repairs should only be undertaken by a Miele authorised service technician. Otherwise the warranty is invalidated.

Warning and Safety instructions

- ▶ Miele can only guarantee the safety of the appliance when genuine original Miele replacement parts are used. Faulty components must only be replaced by Miele spare parts.
- ▶ The hob is not intended for use with an external timer switch or a remote control system.
- ▶ The connection to the gas supply must be carried out by a suitably qualified gas fitter (see “Installation – Gas connection”). If the plug has been removed from the connection cable or the connection cable is not supplied with a plug, the hob must be connected to the electricity supply by a suitably qualified electrician (see “Installation – Electrical connection”).
- ▶ If the mains connection cable is damaged, it must be replaced with a special mains connection cable by a qualified electrician (see “Electrical connection” in the “Installation” chapter).
- ▶ During installation, maintenance and repair work, the hob must be disconnected from the mains electricity supply. The gas supply must also be shut off. Depending on territory this is done in one of several different ways:
 - the mains fuse has been removed, or
 - the screw-out fuse is removed (if applicable), or
 - switch off at the wall socket and withdraw the plug from the socket. Pull by the plug and not by the mains connection cable to disconnect from the mains electricity supply.
 - the gas inlet valve is closed.
- ▶ Risk of electric shock. Do not use the hob if it is faulty, or if the ceramic surface is cracked, chipped or damaged in any way. Switch it off immediately, do not touch the appliance surface and disconnect the hob from the mains electricity supply and the gas supply. Contact the Customer Service Department.

Warning and Safety instructions

► If the hob is installed behind a cabinet door, do not close the door while the hob is in use. Heat and moisture can build up behind the closed door. This can result in damage to the hob, the housing unit and the floor. Leave the furniture door open until the hob has cooled down completely.

Warning and Safety instructions

Correct use

- ▶ The hob gets hot when in use and remains hot for some time after being switched off. Do not touch the hob if there is a possibility that it could still be hot.
- ▶ Due to the high temperatures radiated, objects left near the hob when it is in use could catch fire.
Do not use the hob to heat up the room.
- ▶ Oil and fat can overheat and catch fire. Do not leave the hob unattended when cooking with oil and fat. If it does ignite do not attempt to put the flames out with water.
Disconnect the hob from the mains and use a suitable fire blanket, saucepan lid, damp towel or similar to smother the flames.
- ▶ Do not leave the hob unattended whilst it is being used. It should be continually monitored whilst boiling and flash frying.
- ▶ Flames could set the grease filters of a cooker hood on fire. Do not flambé under a cooker hood.
- ▶ Spray canisters, aerosols and other inflammable substances can ignite when heated. Therefore do not store such items or substances in a drawer under the hob. Cutlery inserts must be heat-resistant.
- ▶ Do not heat an empty pan.
- ▶ Do not heat up food in closed containers e.g. tins or sealed jars on the hob, as pressure can build up in the container, causing it to explode.
- ▶ Do not cover the hob, e.g. with a hob cover, a cloth or protective foil. The material could catch fire, shatter or melt if the hob is switched on by mistake or if residual heat is still present.
- ▶ If the appliance is switched on by mistake, or if there is residual heat present, there is the risk of any metal items placed on the hob heating up. Other materials can melt or catch fire. Do not use the appliance as a resting place for anything.

Warning and Safety instructions

- ▶ You could burn yourself on the hot hob. Protect your hands with heat-resistant pot holders or gloves when handling hot pots and pans. Do not let them get wet or damp, as this causes heat to transfer through the material more quickly with the risk of scalding or burning yourself on steam. Be sure to keep all textiles away from the gas flames. Do not use oversized cloths, tea towels or other similar materials.
- ▶ When using an electrical appliance, e.g. a hand-held food blender, near the hob, ensure that the cable of the electrical appliance cannot come into contact with the hot hob. The insulation on the cable could become damaged.
- ▶ Even a light object can cause damage in certain circumstances. Do not drop anything on the ceramic surface.
- ▶ Plastic and aluminium foil containers melt at high temperatures. Do not use plastic or aluminium foil containers on the hob.
- ▶ When a control knob is pressed down, a spark is generated on the ignitor. Do not press down the control knob while you are cleaning or touching the hob or a burner in the vicinity of an ignitor.
- ▶ If a cooker hood is installed above the hob, ensure that the burners are always covered with a pan when in use. Otherwise flames could reach the cooker hood, parts of which could then be damaged or even set on fire.
- ▶ Only light the gas burners after all burner parts have been properly assembled.
- ▶ Pans must be the correct size for the burner they are used on (see „Pans“). A pan which is too small will be unstable on the pan support. If the pan diameter is too large, flames can spread out to the sides and damage or burn the worktop, wall claddings or surrounding units and also parts of the hob. Miele cannot be held liable for this type of damage.

Warning and Safety instructions

- ▶ Ensure that the flames from the burner do not spread out beyond the base and up the sides of the pan.
- ▶ Do not use pans with very thin bases on this hob, and never heat up empty pans as they could get damaged. This could also damage the appliance.
- ▶ The pan support supplied with the appliance must always be used. Never place a pan on the burner itself.
- ▶ Replace the pan supports carefully to avoid scratching the surface of the hob.
- ▶ Do not use or store flammable materials near this hob.
- ▶ Remove splashes of fat and other food debris from the surface of the hob as soon as possible. These are a fire hazard.
- ▶ Using the hob will cause a build-up of heat and moisture in the room in which it is installed. Ensure that the room has sufficient natural or mechanical means of ventilation, e.g. a cooker hood.
- ▶ If the hob is used for very long periods of time, additional ventilation of the room may be necessary, e.g. by opening windows or doors, or running the cooker hood on the highest setting.
- ▶ Do not use roasting dishes, pans or grilling stones that are large enough to cover more than one burner. The resulting build-up of heat could damage the hob.
- ▶ If the hob has not been used for a long period of time, it should be thoroughly cleaned before it is used again. It is also advisable to have it tested by registered gas installer for safety. This should be done at regular intervals.

Cleaning and care

- ▶ Do not use a steam cleaning appliance to clean this hob. The steam could reach electrical components and cause a short circuit.

Caring for the environment

Disposal of the packing material

The packaging is designed to protect the appliance from damage during transportation. The packaging materials used are selected from materials which are environmentally friendly for disposal and should be recycled.

Recycling the packaging reduces the use of raw materials in the manufacturing process and also reduces the amount of waste in landfill sites.

Disposing of your old appliance

Electrical and electronic appliances often contain valuable materials. They also contain specific materials, compounds and components, which were essential for their correct function and safety. These could be hazardous to human health and to the environment if disposed of with your domestic waste or if handled incorrectly. Please do not, therefore, dispose of your old appliance with your household waste.



Please dispose of it at your local community waste collection / recycling centre for electrical and electronic appliances, or contact your dealer or Miele for advice. You are also responsible (by law, depending on territory) for deleting any personal data that may be stored on the appliance being disposed of. Please ensure that your old appliance poses no risk to children while being stored prior to disposal.

Hob

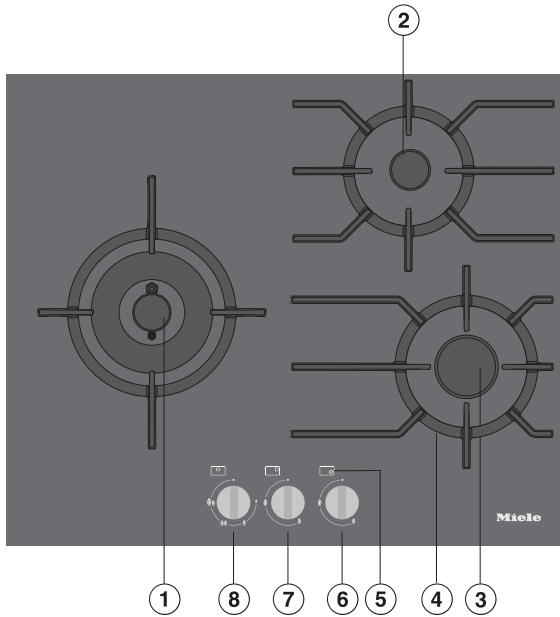

- ① Wok burner
- ② Small burner
- ③ Medium burner
- ④ Pan support (one for each burner)
- ⑤ Cooking zone symbols

Controls knobs for the cooking zones:



- ⑥ Front right
- ⑦ Rear right
- ⑧ Left

Guide to the appliance

Control knobs

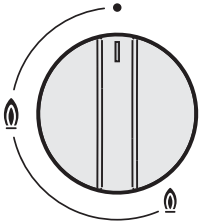



Small, medium and large burners

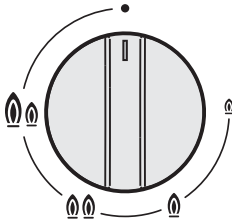

Symbol	Description
•	Burner off, the gas supply is turned off
	Largest flame
	Smallest flame

Wok burner



Symbol	Description
•	Burner off, the gas supply is turned off
	Largest flame: inner and outer burner on highest setting.
	Large flame: outer burner on lowest setting, inner burner on highest setting.
	Small flame: outer burner off, inner burner on highest setting.
	Smallest flame: outer burner off, inner burner on lowest setting.

Burner

Wok burner

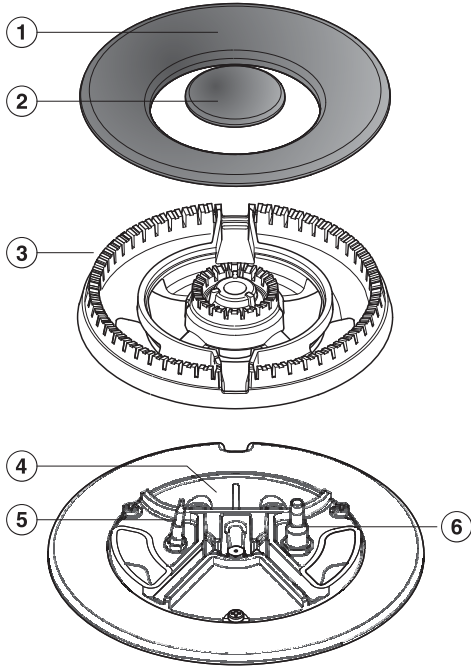

- ① Outer burner cap
- ② Inner burner cap
- ③ Burner head
- ④ Burner base
- ⑤ Thermocouple
- ⑥ Ignitor

Small, medium and large burners

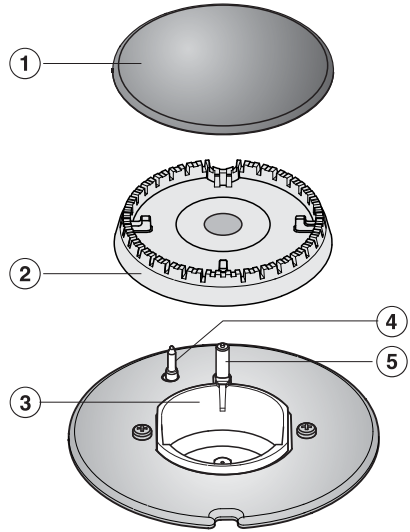

- ① Burner cap
- ② Burner head
- ③ Burner base
- ④ Thermocouple
- ⑤ Ignitor

Guide to the appliance

Accessories supplied

The accessories supplied with your appliance as well as a range of optional ones are available to order from Miele (see “Optional accessories”).

Accessories supplied with KM 3014 only:

Wok ring

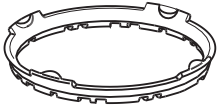

The wok ring supplied gives additional stability to the wok, especially to woks with a rounded base.

Combination trivet

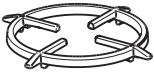

The combination trivet supplied must be used if you are using pans with a smaller base diameter than that specified in the chart for suitable pans.

- Please stick the extra data plate for the appliance supplied with this documentation in the space provided in the “After sales service” section of this booklet.
- Remove any protective wrapping and stickers.

Cleaning the hob for the first time

- Before using for the first time, clean the hob with a damp cloth only and then wipe dry.
- Clean all removable parts of the burners with a solution of warm water and a small amount of washing-up liquid applied with a soft sponge. Dry all parts thoroughly after cleaning and then reassemble the burners (see “Cleaning and care”).

Switching on the hob for the first time

The metal components have a protective coating which when heated for the first time will give off a slight smell and possibly some vapours.

The smell and any vapours given off do not indicate a faulty connection or appliance and they are not hazardous to health.

Pans

Minimum pan base diameter	
Burner	Ø cm
Small burner	10
Medium burner	12
Large burner	14
Wok burner	14

Maximum diameter at top of pan	
Burner	Ø cm
Small burner	20
Medium burner	22
Large burner	24
Wok burner	26

- Select the pan to suit the size of the burner:
large diameter = large burner
small diameter = small burner.
- Observe the dimensions given in the chart. Using pans that are too large can cause the flames to spread out and damage the surrounding worktop or other appliances. Using pans of the correct size improves efficiency. Pans that are smaller than the pot rests and pans that do not stand safely (without wobbling) on the pot rests are dangerous and should not be used.
- In contrast to pans for use on electric hobs, the bases of pans for use on gas hobs do not need to be flat to achieve good results.
- Remember when purchasing new pans that manufacturers usually refer to the diameter at the top of the pan in their documentation, and not to the base diameter.
- You can use any cookware that is heat-resistant.
- Cookware with a thick base is preferable as the heat is distributed evenly. With thinner based cookware, there is the risk that food will overheat in places. Therefore it should be stirred more frequently.
- Always place the cookware on the pot rests supplied. Do not place cookware directly on the burners.
- Place the cookware on the pot rests in such a way that it cannot tip over. A minor wobble can never be completely excluded.
- Do not use pots or pans with an edge-supported base.



Wok ring

- Use the wok ring supplied to give additional stability to pans, especially to woks with a rounded base.

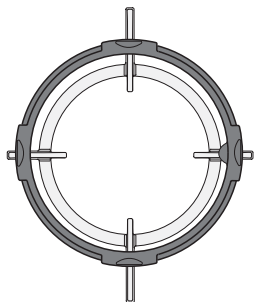

- Place the wok ring on the pan support so that it sits securely in position and cannot move (see diagram).

The wok is unique among cookware in that it has a small base diameter and a large rim diameter (usually 35-40 cm). Wok pans are ideal for use on the wok burner.

Combination trivet

The combination trivet must be used if you wish to use a pan with a smaller diameter base than the minimum given in the table.

Tips on saving energy

- Use a pan lid whenever possible to minimize heat loss.

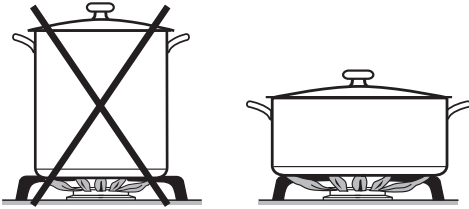

- Wide, shallow pans are preferable to tall, narrow ones. They will heat up faster.
- Cook with as little water as possible.
- Reduce the size of the flame once the water has come to the boil or the oil is hot enough to fry in.
- Use a pressure cooker to reduce cooking times.

 Risk of fire with overheated food. Unattended food can overheat and catch alight. Do not leave the hob unattended whilst it is being used.

Switching on

- Press in the relevant rotary control and turn it anticlockwise to the large flame symbol. The ignition electrode will “click” and ignite the gas.

When the rotary control is operated, a spark is automatically produced on all burners. This is normal and does not indicate a fault.

- When a flame is visible, keep the rotary control pressed down for 5–10 seconds, and then let it go.
- If the burner does not ignite, turn the rotary control to the • position. Ventilate the room or wait for at least 1 minute before trying again. When making another ignition attempt, it may be necessary to hold the rotary control for longer.
- If the burner does not ignite the second time, turn the rotary control back to the • position and see “Problem solving guide”.

Switching on during a power outage

If there is an interruption to the electricity supply, the gas can be ignited manually, e.g. with a match.

- Press in the relevant control and turn it anti-clockwise to the large flame symbol.
- Hold the control pressed in and light the gas at the burner with a match.
- Keep the control pressed in for a further 5-10 seconds and then release it.

Operation

Adjusting the flame

The burners can be regulated at any level between the strongest and weakest flame.

As the outer part of the flame is much hotter than the centre, the tips of the flames should stay beneath the pan base. Flame tips which extend beyond the sides of the pan merely warm up the air in the room and can also damage pan handles and increase the danger of injury.

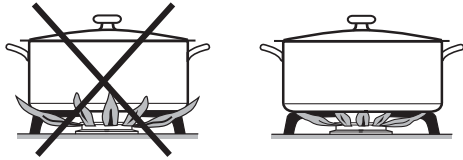

- Adjust the flame so that it does not spread out beyond the sides of the pan.

Wok burner

Depending on the type of control knob, there may be a stopper between the low and high settings at the 6 o'clock position.

- Press the control knob down lightly to move past this resistance.

Switching off

- Turn the rotary control clockwise to the • position.

The gas supply is cut off and the flame goes out.

Thermo-electric flame failure monitor

Your hob is equipped with a thermo-electric flame failure monitor. If a gas flame is extinguished, e.g. by food boiling over or by a draught, the gas supply is switched off. This prevents the release of gas. If you turn the rotary control to the ● position, the burner is ready for use again.

The thermo-electric flame failure monitor operates independently from the electricity supply. This means that it will still work if the hob is used during a power cut.

Cleaning and care

 Danger of burning due to hot surfaces.

The hob surface, pan supports and burners will be hot after use.

Allow the hob to cool down before cleaning it.

 Risk of damage due to moisture ingress.

The steam from a steam cleaning appliance could reach live electrical components and cause a short circuit.

Do not use a steam cleaner to clean the hob.

All surfaces could be discoloured or damaged if unsuitable cleaning agents are used. All surfaces are susceptible to scratching.

Remove all cleaning agent residues immediately.

Never use abrasive sponges or cleaning agents.

Food boiling over can cause discoloration of the burner components.

Remove any soiling and salt and sugar splashes immediately.

When a control knob is pressed down, a spark is generated on the ignitor. Do not press down the control knob while you are cleaning or touching the hob or a burner in the vicinity of an ignitor.

Unsuitable cleaning agents

To avoid damaging the surfaces of the appliance, do not use:

- cleaning agents containing soda, alkalines, ammonia, acids or chlorides
- cleaning agents containing descaling agents
- stain and rust removers
- abrasive cleaning agents, e.g. powder cleaners and cream cleaners
- solvent-based cleaning agents
- dishwasher cleaner
- oven sprays
- glass cleaning agents
- hard, abrasive brushes or sponges (e.g. pot scourers), or sponges which have been previously used and still contain abrasive cleaning agents
- melamine eraser blocks

- The entire hob should be cleaned after each use.
- Soften any stubborn soiling beforehand.
- Dry the hob thoroughly after every damp cleaning to avoid limescale residue.

Ceramic surface

 Risk of damage by pointed objects.

The seal between the hob and the worktop could suffer damage. The seal between the ceramic surface and the frame could suffer damage.

Do not use pointed objects for cleaning.

Not all soiling and residues can be removed using a solution of washing-up liquid. An invisible film can develop that can lead to discolouration of the glass ceramic surface. This discolouration cannot be removed.

Clean the ceramic surface regularly with a proprietary ceramic glass cleaning agent.

- Remove any coarse soiling with a damp cloth and more stubborn soiling with a shielded scraper blade suitable for use on glass.
- Then clean the ceramic glass surface with the Miele ceramic and stainless steel hob cleaner (see “optional accessories”) or with a proprietary ceramic glass cleaner applied with kitchen paper or a clean cloth. Do not apply cleaner whilst the hob is still

hot, as this could result in marking. Please follow the cleaning agent manufacturer's instructions.

- **Spots** caused by limescale or water can be removed using Miele's ceramic and stainless steel hob cleaner.
- Wipe the surface afterwards with a damp cloth to remove any cleaning agent residues.

Residues can burn on the next time the appliance is used and cause damage to the ceramic surface. Ensure that all cleaning agent residues are removed.

- Dry the ceramic surface with a clean, soft cloth.

Cleaning and care

Pan supports

- Remove the pan supports.
- Clean the pan supports in the dishwasher or with a solution of warm water and a little washing-up liquid applied with a soft sponge. Stubborn soiling should be soaked first.
- After cleaning, dry the pan supports thoroughly with a clean cloth.

Control knobs

The control knobs are not dishwasher-safe.
The control knobs should only be cleaned by hand.

The rotary controls can become discoloured if they are not cleaned regularly.
Clean the control knobs after each use.

- Clean the control knobs using a solution of warm water and a little washing-up liquid applied with a soft sponge.

Burner

Do not clean any parts of the burners in a dishwasher.

The surface of the burner cap will become duller with time. This is completely normal and does not indicate material deterioration.

- The burner should be dismantled and then cleaned by hand using a solution of warm water and a little washing-up liquid applied with a soft sponge.
- Clean any soiling from the flame openings.



Danger of explosion.

Blocked flame openings can cause a dangerous build-up of gas in the base of the hob which could ignite and cause an explosion. This can lead to damage to the appliance and injury.

Ensure the flame openings are kept clean at all times.

- Parts of the burner that cannot be removed should be wiped clean with a damp cloth only.
- The ignitor and thermocouple should be very carefully wiped clean using a well wrung-out cloth.

The ignitor must not get wet, otherwise it will not spark.

- Finally dry everything thoroughly with a clean cloth. Make sure that the flame openings are completely dry.

Assembling the small, medium and large burners

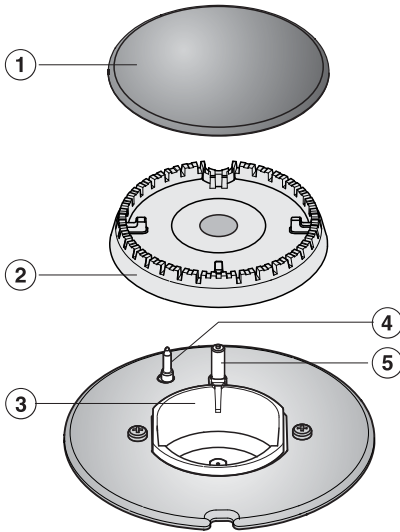

- Place the burner head ② on the burner base ③ so that the thermocouple ④ and the ignitor ⑤ extend through their respective holes in the burner head. The burner head must click into place correctly.
- Place the burner cap ① flat over the burner head ②. When correctly positioned, the burner cap will not slide about.

Ensure parts are reassembled in the correct order.

Assembling the wok burner

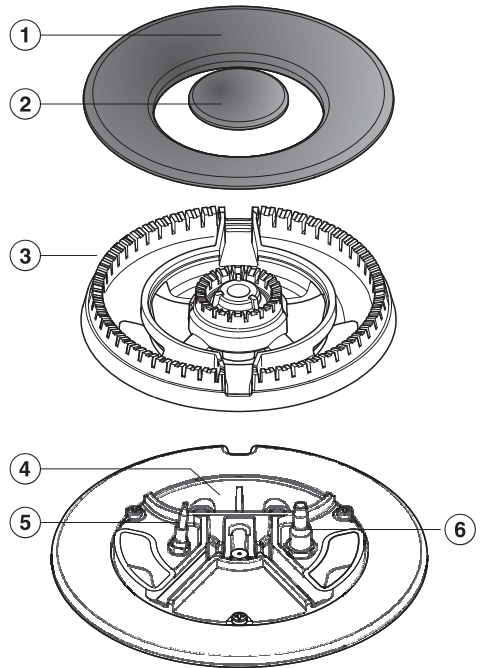

- Place the burner head ③ on the burner base ④ so that the thermocouple ⑤ and the ignitor ⑥ extend through their respective holes in the burner head. The burner head must click into place correctly.
- Then place the burner caps ① and ② in position.

Ensure parts are reassembled in the correct order.

Problem solving guide

Many malfunctions and faults that can occur in daily operation can be easily remedied. Time and money will be saved because a service call will not be needed.

The following guide may help you to find the reason for a malfunction or a fault, and to correct it.

Problem	Cause and remedy
The burners do not ignite when the hob is being used for the first time or after it has been out of use for a longer period.	There could be an air lock in the gas pipe. <ul style="list-style-type: none"> ■ You may need to make several attempts before the burner ignites successfully.
The burner does not light after several attempts.	There is a technical fault. <ul style="list-style-type: none"> ■ Turn all of the controls clockwise to the • position and interrupt the power supply to the hob for a few seconds.
	The burner is not correctly assembled. <ul style="list-style-type: none"> ■ Assemble the burner correctly.
	The gas shut-off device has not been opened. <ul style="list-style-type: none"> ■ Open the gas shut-off device.
	The burner is wet and/or dirty. <ul style="list-style-type: none"> ■ Clean and dry the burner.
	The flame openings are blocked and/or wet. <ul style="list-style-type: none"> ■ Clean and dry the flame openings.
The gas flame goes out after ignition.	The flames do not touch the thermocouple and the burner does not get hot enough: The burner parts are not positioned correctly. <ul style="list-style-type: none"> ■ Assemble the burner components correctly.
	The thermocouple is dirty. <ul style="list-style-type: none"> ■ Remove any soiling.
The flame suddenly looks different.	The burner parts are not positioned correctly. <ul style="list-style-type: none"> ■ Position the burner parts correctly.
	The burner head or the holes in the burner cap are dirty. <ul style="list-style-type: none"> ■ Remove any soiling.

Problem solving guide

Problem	Cause and remedy
The gas flame goes out during use.	The burner parts are not positioned correctly. ■ Position the burner parts correctly.
The ignitor on the burner does not spark.	The mains fuse has tripped. ■ You may need to contact a registered electrical worker or Miele.
	There is food residue stuck between the ignitor and the burner cap. There is food residue on the thermocouple. ■ Remove any soiling (See „Cleaning and care“).

Optional accessories

Miele offer a comprehensive range of useful accessories as well as cleaning and conditioning products for your Miele appliances.

These products can be ordered through the Miele Webshop.

They can also be ordered from Miele (see end of this booklet for contact details) or from your Miele dealer.

Ceramic and stainless steel hob cleaner 250 ml



Removes heavy soiling, limescale deposits and aluminium residues

Microfibre cloth

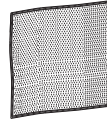

Removes finger marks and light soiling

Contact in the event of a fault

In the event of any faults which you cannot remedy yourself, please contact your Miele dealer or the Miele Customer Service Department.

You can book a Miele Customer Service Department call-out online at www.miele.com/service.

Contact information for the Miele Customer Service Department can be found at the end of this document.

Please quote the model identifier and serial number of your appliance (Fabr./SN/ Nr.) when contacting the Miele Customer Service Department. This information can be found on the data plate.

Please note that telephone calls may be monitored and recorded for training purposes and that a call-out charge will be applied to service visits where the problem could have been resolved as described in this booklet.

Data plate

Stick the extra data plate supplied with the appliance here. Make sure that the model number matches the one specified on the back cover of this document.





Guarantee

For information on the appliance guarantee specific to your country please contact Miele. See end of this booklet for contact details.

Installation

Safety instructions for installation

 Risk of damage from incorrect connection.
Incorrect installation can cause damage to the hob.
The hob must only be installed by a qualified person.

 Damage from falling objects.
Take care not to damage the hob when fitting wall units or a cooker hood above it.
Fit the wall units and the cooker hood before the hob.

- ▶ The room in which the hob is installed must conform to all relevant local and national building regulations and safety regulations.
- ▶ The veneer or laminate coatings of worktops (or adjacent kitchen units) must be treated with 100 °C heat-resistant adhesive which will not dissolve or distort. Any backmoulds must be of heat-resistant material.
- ▶ The hob must not be installed over a fridge, fridge-freezer, freezer, dishwasher, washing machine, washer-dryer or tumble dryer.
- ▶ A gas hob must not be installed directly next to a deep fat fryer as the gas flames could ignite the fat in the fryer. It is essential to maintain a distance of at least 300 mm between these two appliances.
- ▶ When installing the hob, make sure that the gas pipe and electrical connection cable cannot come into contact with hot appliance parts.
- ▶ The electrical cable and any flexible gas connection pipes must be installed in such a way so that they do not come into contact with any moving kitchen parts (e.g. a drawer), and cannot become trapped.
- ▶ Observe carefully the safety clearances listed on the following pages.

Safety distances

Safety distance above the hob

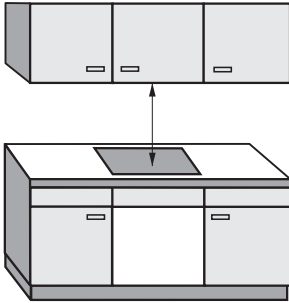

A minimum safety distance must be maintained between the appliance and the cooker hood above it. See the cooker hood manufacturer's operating and installation instructions for details. If the manufacturer's instructions are not available for the cooker hood or if any flammable objects (e.g. utensil rails, wall units etc) are installed above the hob a minimum safety distance of at least 760 mm must be maintained between them and the appliance below.

When two or more appliances which have different safety distances are installed together below a cooker hood, you should observe the greatest safety distance.

Installation

Safety distances to the sides and back of the hob

Ideally the hob should be installed with plenty of space on either side. There may be a wall at the rear or a tall unit or wall on one side (right **or** left) (see illustrations).

- ① Minimum distance between the **back** of the worktop cut-out and the rear edge of the worktop: 50 mm
- ② Minimum distance between the worktop cut-out and a wall or tall unit to the **right** of it: 150 mm.
- ③ Minimum distance between the worktop cut-out and a wall or tall unit to the **left** of it: 150 mm.

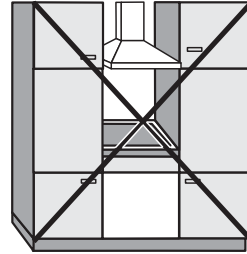

Not allowed

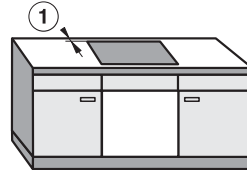
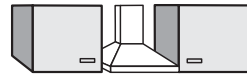

Highly recommended

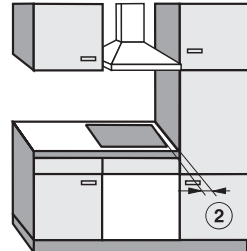

Not recommended

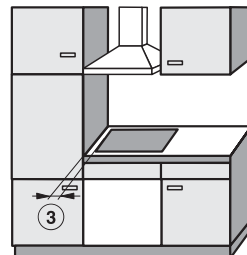

Not recommended

Safety distance when installing the appliance near a wall with additional niche cladding

A minimum safety distance must be maintained between the worktop cut-out and any niche cladding to protect it from heat damage.

If the niche cladding is made from a combustible material (e.g. wood) a minimum safety distance ⑤ of 50 mm must be maintained between the cut-out and the cladding.

If the niche cladding is made from a non-combustible material (e.g. metal, natural stone, ceramic tiles) the minimum safety distance ⑤ between the cut-out and the cladding will be 50 mm less the thickness of the cladding.

Example: 15 mm niche cladding

50 mm - 15 mm = minimum safety distance of 35 mm

Flush-fitted hobs

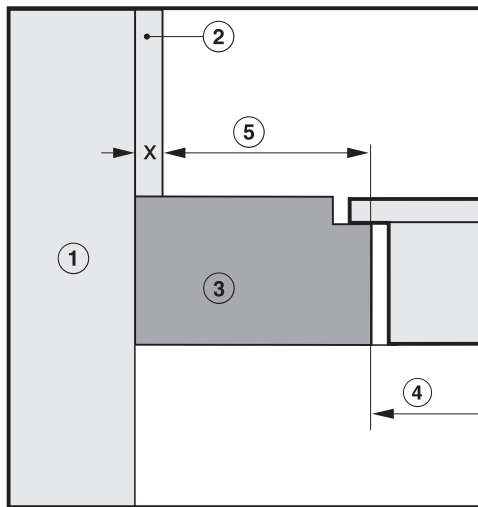

Hob with frame or bevelled edge

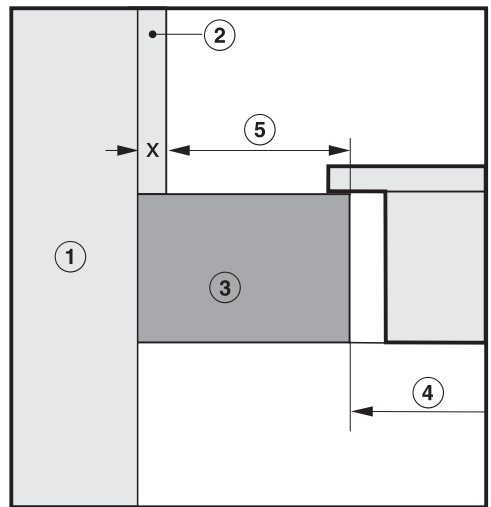



- ① Masonry
- ② Niche cladding dimension x = thickness of the niche cladding material
- ③ Worktop
- ④ Worktop cut-out
- ⑤ Minimum distance to
 - combustible** materials 50 mm
 - non-combustible** materials 50 mm - dimension x

Installation

Installation notes

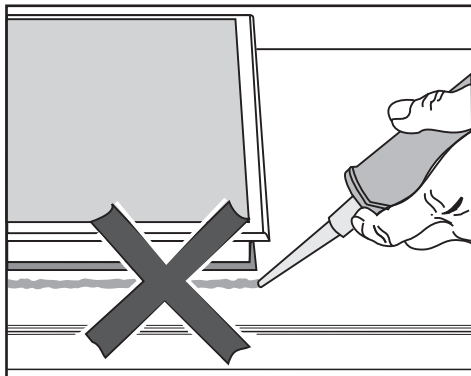
Seal between the hob and the worktop



 Damage caused by incorrect installation.

Using sealant under the hob could result in damage to the hob and the worktop if the hob ever needs to be removed for servicing.

Do not use sealant between the hob and the worktop.

The sealing strip under the edge of the hob provides a sufficient seal for the worktop.

Tiled worktops

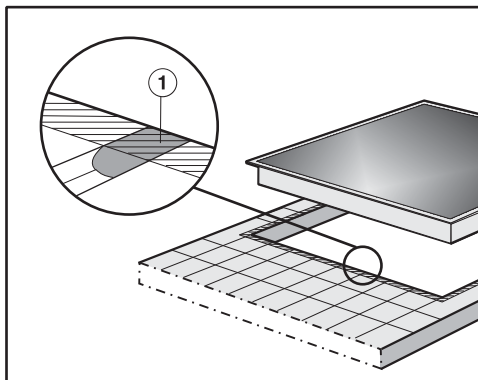

Grout lines ① and the hatched area underneath the hob frame must be smooth and even. If they are not the hob will not sit flush with the worktop and the sealing strip underneath the hob will not provide a good seal between the hob and the worktop.

Building-in dimensions

All dimensions are given in mm.

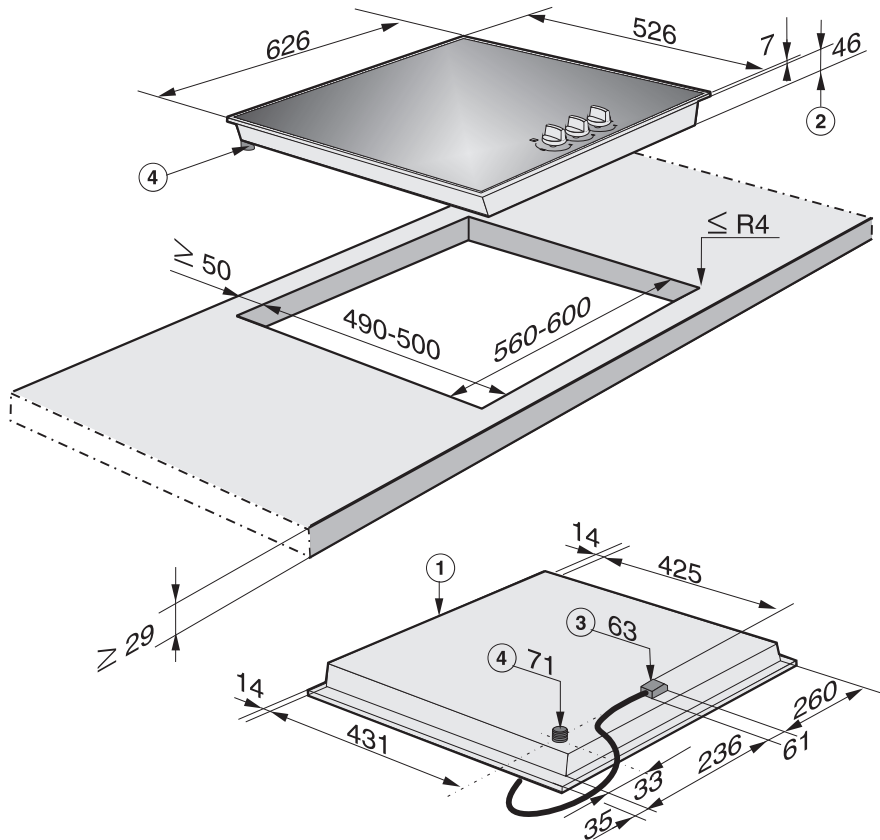

- ① Front
- ② Casing depth
- ③ Mains connection box with mains connection cable, L = 1440 mm
- ④ Gas connection R 1/2

Installation

Installation

Preparing the worktop

- Create the worktop cut-out as shown in the hob diagram. Remember to maintain the minimum safety distances (see “Installation – Safety distances”).
- Seal any cut surfaces on wooden worktops with a special varnish, silicone sealant or resin to prevent the wood from swelling as a result of moisture ingress. The sealant must be heat-resistant.

Make sure that the sealant does not come into contact with the top of the worktop.

The seal under the appliance ensures that the hob will sit securely in the cut-out without slipping. Any gap between the appliance frame and worktop will become smaller over time.

Installing the hob

- Stick the supplied sealing strip under the edge of the hob.
- Feed the power cable for the hob down through the worktop cut-out.
- Place the hob loosely in the cut-out. When doing this, make sure that the seal of the appliance sits flush with the worktop on all sides. This is important to ensure an effective seal all round.

If the seal does not sit flush with the worktop in the corners, the corner radius ($\leq R4$) can be carefully cut to fit using a jigsaw.

Do not use any additional sealant (e.g. silicone) on the hob.

- Connect the hob to the electricity supply (see “Installation – Electrical connection”).
- Connect the hob to the gas supply (see “Installation – Gas connection”).

Securing the hob

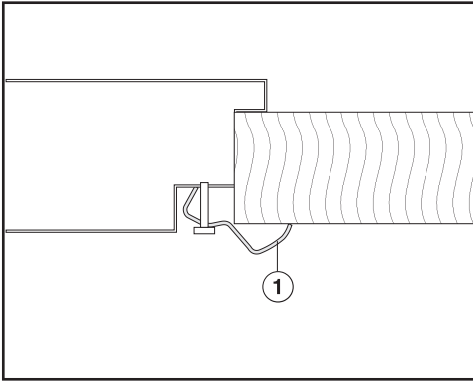

- Secure the hob using the brackets ① supplied.

Functional check

- After installing the hob, ignite all burners to check that they are operating correctly:
 - The flame must not go out on the lowest setting, or when the control is turned quickly from the highest to the lowest setting.
 - On the highest setting, the flame must have a distinctive and visible core.

Installation

Gas connection

⚠ According to the Gas Safety (Registration of Gas Installers and Gas Contractors) Regulations, any gas installation work including the installation of appliances and connecting tubing, must be undertaken by a registered gas installer who is registered for that appropriate class and is employed by a registered gas contractor. The installer is responsible for ensuring that the appliance functions correctly when installed.

Use approved gas tubing for connection to appliances.

The gas connection must be installed so that connection can be made either from inside or outside the kitchen unit. The isolating valve must be easily accessible and visible (by opening the kitchen door if necessary).

Check with your local gas supplier about the type of gas its calorific value and compare this information with the type of gas quoted on the appliance's data plate.

This hob is not connected to an exhaust flue.
When installing and connecting the appliance please observe all relevant installation instructions and ensure it has adequate ventilation once installed.

Connection to the gas supply must be carried out in strict accordance with current local regulations. Every appliance should have its own easily accessible isolating valve and test point.

Any special local conditions relating to gas installations as well as building regulations must also be observed.

Gas connections, pipes and connection cables can suffer damage if exposed to heat from the hob.
After installation make sure that neither the gas pipe nor the mains cable can come into contact with hot parts of the appliance and that the gas pipe and connections on the hob cannot come into contact with hot gas exhaust.

Flexible gas pipes can be damaged by incorrect routing.
Attach flexible gas pipes in such a way so that they do not come into contact with any moving kitchen parts (e.g. a drawer) and are not exposed to mechanical stress.

The hob must be set for local gas conditions and the gas connection must undergo a leakage test.

Depending on country of destination this appliance is set up for connection to Natural gas, Liquefied Petroleum gas (LPG) or Town gas (TG). See adhesive label on the appliance.

Depending on country, a set of jets for conversion to an alternative type of gas may be included with the hob. Please contact your supplier or Miele for the appropriate conversion jets if necessary. Conversion to another type of gas is described under „Conversion to another type of gas“.

Appliances set up for connection to town gas have a gas governor included.

Inlet pressure

Natural gas	20 mbar
LPG	28 mbar
Town gas	10 mbar

Connecting the hob

The hob is supplied with a conical $\frac{1}{2}$ " gas connection point for connection to one of the following:

- Rigid connection with isolation valve
- Flexible connection, maximum length 2000 mm.

Unsuitable sealants may not be leak-proof.

Connections must be sealed using appropriate sealant.

- After installation, turn on the gas supply and use soap solution to check for gas leakage.

Never use a naked flame!

⚠ According to the Gas Safety (Registration of Gas Installers and Gas Contractors) Regulations, any gas installation work including the installation of appliances and connecting tubing, must be undertaken by a registered gas installer who is registered for that appropriate class and is employed by a registered gas contractor.

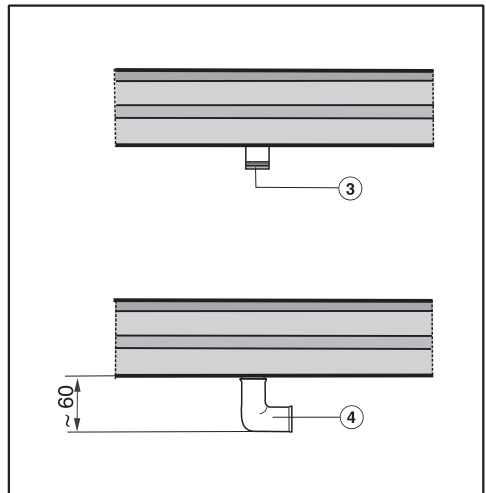

③ Connection R $\frac{1}{2}$ "

④ 90° bend

Installation

Gas Governor

The gas governor is only included with appliances set up for connection to Town gas.

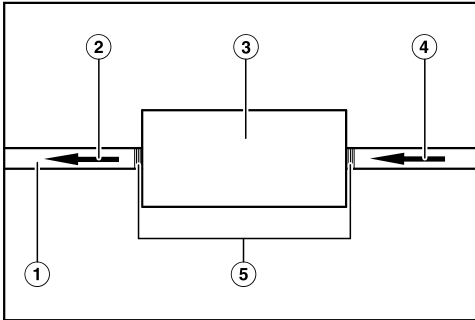

- ① Connection to the hob
- ② Outlet pressure (10 mbar)
- ③ Gas Governor
- ④ Inlet Pressure (max. 50 mbar)
- ⑤ 1/2" BSP

LP Gas Connection - elbow joint connection

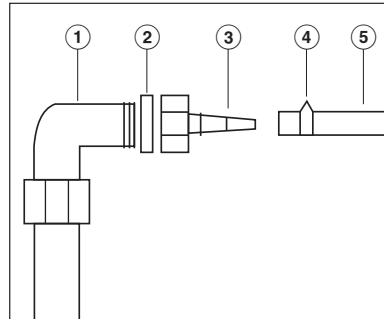

- ① Elbow joint
- ② Gasket
- ③ Nozzle
- ④ Ring
- ⑤ Rubber hose

The gasket depicted above is to prevent gas leakage.

Burner ratings

Nominal ratings

Burner	Gas type	Highest setting		Lowest setting
		kW	g/h	kW
Small burner	Natural gas	1.0	–	0.25
	Town gas	1.3	–	0.19
	Liquid gas	0.95	69	0.2
Medium burner	Natural gas	1.7	–	0.3
	Town gas	2.0	–	0.38
	Liquid gas	1.7	124	0.35
Wok	Natural gas	4.7	–	0.3
	Town gas	4.9	–	0.18
	Liquid gas	4.5	327	0.25
Total	Natural gas	7.4	–	
	Town gas	8.2	–	
	Liquid gas	7.15	520	

Installation

Electrical connection

All electrical work must be carried out by a suitably qualified and competent person in strict accordance with current local and national safety regulations. Connection must be made via a switched socket. This will make it easier for service technicians should the appliance need to be repaired. The electrical socket must be easily accessible after installation.



Danger of injury.

Miele cannot be held liable for unauthorised installation, maintenance and repair work as this can be dangerous to users.

Miele cannot be held liable for damage or injury caused by incorrect installation, maintenance or repair work, or by an inadequate or faulty earthing system (e.g. electric shock).

If the plug is removed from the connection cable or if the cable is supplied without a plug, the appliance must be connected to the electrical supply by a suitably qualified electrician.

If the switched socket is not accessible after installation, or if the appliance is to be hard-wired, an additional means of disconnection must be provided for all poles. When switched off, there must be an all-pole contact gap of at least 3 mm in the switch (including switch, fuses and relays). Connection data is shown on the data plate. It must match the mains electrical supply.

After installation ensure that all electrical components are shielded and cannot be accessed by users.

Total power rating

See data plate

Connection data

The connection data is quoted on the data plate. Please ensure these match the household mains supply.

The wires in the mains lead are coloured in accordance with the following code:

Green/yellow = earth

Blue = neutral

Brown = live

WARNING

THIS APPLIANCE MUST BE EARTHED

Residual current device

For extra safety, it is advisable to protect the appliance with a suitable residual current device (RCD) with a trip range of 30 mA.

Disconnecting from the mains



Risk of electric shock.

There is a risk of electric shock if the appliance is connected to the mains supply during repair or service work. After disconnection, ensure the appliance cannot be switched back on by mistake.

To disconnect the appliance from the mains power supply, do one of the following depending on installation:

Safety fuses

- Completely remove fuses.

Automatic circuit breakers

- Press the (red) test button until the middle (black) button springs out.

Built-in circuit breakers

- Circuit breakers at least type B or C:
Switch the lever from 1 (on) to 0 (off).

Residual current device (RCD)

- Switch the main switch from 1 (on) to 0 (off) or press the test button.

Replacing the mains connection cable



Risk of electric shock.

Incorrect connection to the power supply may result in an electric shock.

The mains cable must only be replaced by a qualified electrician.

When replacing the mains cable only use cable type H 05 VV-F with a suitable cross section. A suitable connection cable is available to order from Miele.

Converting to another gas type

 Risk of explosion due to an incorrect conversion.

If the conversion to another type of gas is carried out incorrectly, it may result in gas leakage.

Conversion from one type of gas to another must only be undertaken by an approved and registered gas installer in strict accordance with current local and national safety and building regulations. The installer is responsible for ensuring that the appliance functions correctly when installed.

When converting to another type of gas, both the main **and** small jets need to be changed.

The external gas governor delivered with the appliance should not be installed when using Liquid gas or Natural gas.

Jet table

The jet markings refer to a $\frac{1}{100}$ mm bore diameter.

	Ø	
	Main jet	Small jet
Natural gas		
Small burner	0.76	0.39
Medium burner	0.94	0.42
Large burner	1.20	0.54
Wok burner	2x 1.07 / 0.72	0.42
Town gas		
Small burner	1.50	0.60
Medium burner	1.92	0.80
Large burner	2.50	0.90
Wok burner	2x 2.50 / 1.30	0.54
Liquid gas		
Small burner	0.52	0.23
Medium burner	0.66	0.36
Large burner	0.81	0.42
Wok burner	2x 0.70 / 0.46	0.25

Converting to another gas type

Changing the jets

- Disconnect the hob from the electricity supply and turn off the gas supply.

Changing the main jets

Small, medium and large burners

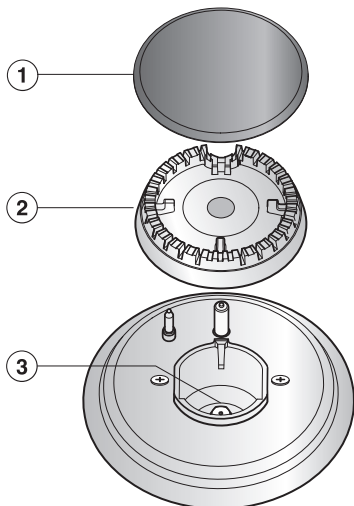

- Remove the pan support, burner cap ① and burner head ②.
- Using an M7 socket spanner, unscrew the main jet ③.
- Fit the correct jets securely (see jet table).
- Secure the jets against inadvertent loosening with sealing wax.

Wok burner

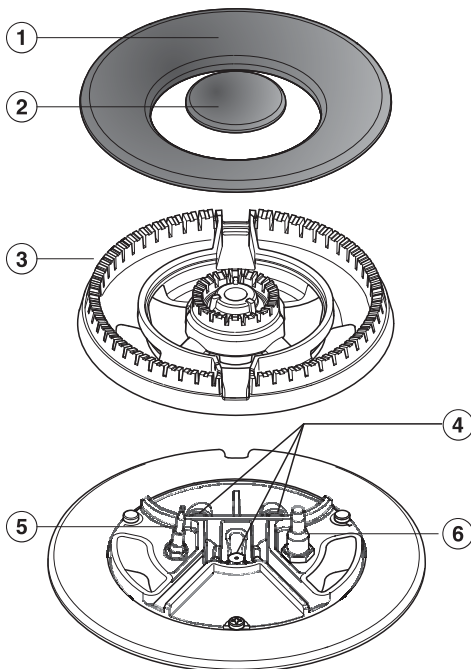

- Remove burner caps ① ② and burner head ③.
- Using an M7 socket spanner, unscrew the main jets ④.
- Fit the correct jets securely (see jet table).
- Secure the jets against inadvertent loosening with sealing wax.

Converting to another gas type

Changing the small jets

To change the small jets, the burner fixing screws must first be loosened and the upper section of the appliance removed.

- Pull the control knobs off.
- Remove the burner components.

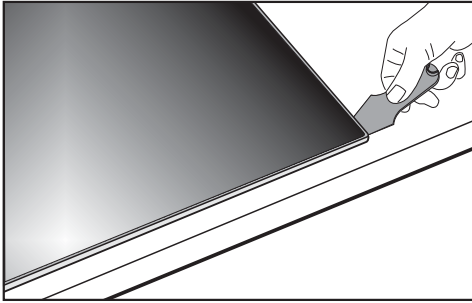

- Lift the top of the appliance off (see illustration).

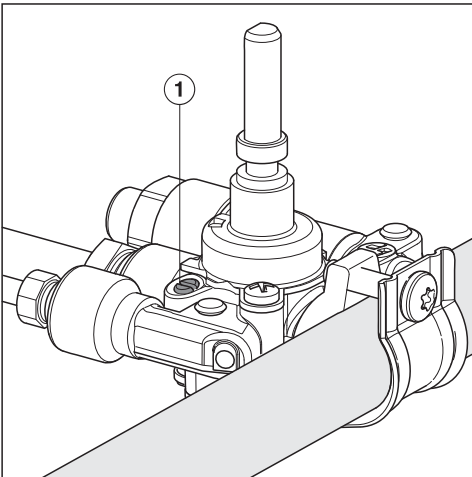

- Using a small screwdriver, unscrew the small jet ① in the gas fitting.
- Pull out the jet with a pair of pliers.
- Fit the correct jets securely (see jet table).

- Secure the jets against inadvertent loosening with sealing wax.

Functional check

- Check all gas fittings for leaks.
- Reassemble the hob.
- Ignite all burners to check that they are operating correctly.
 - The flame must not go out on the lowest setting, or when the control is turned quickly from the highest to the lowest setting.
 - On the highest setting, the flame must have a distinctive and visible core.
- Adhere the label supplied with the jets, stating the type of gas being used.

Singapore

Miele Pte. Ltd.
29 Media Circle
#11-04 ALICE@Mediapolis
Singapore 138565
sTel: +65-67351191
Fax: +65-67351161
E-Mail: info@miele.com.sg
Internet: www.miele.sg

Malaysia

Miele Sdn Bhd
Suite 12-2, Level 12
Menara Sapura Kencana Petroleum
Solaris Dutamas No. 1
Jalan Dutamas 1
50480 Kuala Lumpur, Malaysia
Phone: +603-6209-0288
Fax: +603-6205-3768

Germany

Miele & Cie. KG
Carl-Miele-Straße 29
33332 Gütersloh

Hong Kong, China

Miele (Hong Kong) Limited
41/F - 4101, Manhattan Place
23 Wang Tai Road, Kowloon Bay
Hong Kong
Tel: (852) 2610 1025
Fax: (852) 3579 1404
Email: customerservices@miele.com.hk
Website: www.miele.hk

Thailand

Miele Appliances Ltd.
BHIRAJ TOWER at EmQuartier
43rd Floor Unit 4301-4303
689 Sukhumvit Road
North Klongton Sub-District
Vadhana District
Bangkok 10110, Thailand

KM 3014

en-SG

M.-Nr. 11 614 910 / 01