

Operating and installation instructions Induction hobs



To avoid the risk of accidents or damage to the appliance it is **essential** to read these instructions before it is installed and used for the first time.

Warning and Safety instructions	6
Caring for the environment	16
Guide to the appliance	17
Hob.....	17
KM 7679 FR, KM 7679 FL, KM 7879 FL	17
KM 7629 FX, KM 7699 FR, KM 7899 FL	18
KM 7689 FL.....	19
Controls and display	20
Cooking zones.....	22
Before using for the first time	25
Cleaning the hob for the first time	25
Switching on the hob for the first time	25
Miele@home	26
Con@ctivity.....	29
How it works	31
Noises.....	31
Power management	32
Pans	33
Tips on saving energy	35
Setting range	36
Operation	37
Using the appliance.....	37
Switching on the hob	38
Setting the power level.....	38
Switching off a cooking zone	38
Residual heat indicator.....	38
TempControl.....	39
Power level setting - Extended setting range.....	42
PowerFlex cooking area	43
Auto heat-up	44
Booster function.....	45
Keeping warm/Warming food.....	46
Enabling CookAssist actions.....	47
Timer	48
Minute minder	48
Auto switch off	49

Contents

Using both timer functions at the same time	50
Additional functions	51
Stop & Go	51
Recall	51
Wipe protection	52
Demonstration mode	52
Displaying hob data	52
Safety features	53
System lock/safety lock	53
Safety switch-off	54
Overheating protection	55
Programming	56
Cleaning and care	61
Problem solving guide	63
Messages in the display	63
Unexpected behaviour	65
Unsatisfactory results	66
General problems or technical faults	66
Optional accessories	67
After sales service	68
Contact in case of malfunction	68
Data plate	68
Guarantee	68
Installation	69
Safety instructions for installation	69
Safety distances	70
Installation notes	74
Surface-mounted installation	74
Flush-fit installation	75
Sealing strip	75
Installation dimensions – Surface-mounted	76
KM 7679 FR	76
KM 7689 FL	77
KM 7699 FR	78
KM 7679 FL, KM 7879 FL	79
KM 7899 FL	80
Surface-mounted installation	81

Contents

Installation dimensions – Flush-fit	82
KM 7629 FX.....	82
KM 7689 FL.....	83
KM 7679 FL, KM 7879 FL	84
KM 7899 FL.....	85
Flush-fit installation	86
Electrical connection.....	87

Warning and Safety instructions

This hob complies with all relevant local and national safety requirements. Inappropriate use can, however, lead to personal injury and material damage.

Read the operating and installation instructions carefully before using the hob. They contain important information on safety, installation, use and maintenance. This prevents both personal injury and damage to the hob.

Miele expressly and strongly advises that you read and follow the instructions in the chapter on installing the hob as well as the safety instructions and warnings.

Miele cannot be held liable for injury or damage caused by non-compliance with these instructions.

Keep these instructions in a safe place and pass them on to any future owner.

Correct application

- ▶ This hob is intended for domestic use and use in other similar environments.
- ▶ This hob is not intended for outdoor use.
- ▶ It is intended for domestic use only to cook food and keep it warm. Any other use is not supported by the manufacturer and could be dangerous.
- ▶ This hob is not intended for use by people with reduced physical, sensory or mental capabilities or lack of experience and knowledge, unless they have been given supervision and instruction concerning its use by a person responsible for their safety. They may only use the hob unsupervised if they have been shown how to use it in a safe way. They must be able to recognise and understand the dangers of misuse.

Warning and Safety instructions

Safety with children

- ▶ Children under 8 years of age must be kept away from the hob unless they are constantly supervised.
- ▶ Children over 8 years of age may use the hob without supervision if its operation has been clearly explained to them and they are able to use it safely. Children must be able to understand and recognise the possible dangers caused by incorrect operation.
- ▶ Children must not be allowed to clean the hob unsupervised.
- ▶ Please supervise children in the vicinity of the hob and do not let them play with it.
- ▶ The hob gets hot when in use and remains hot for a while after being switched off. Keep children well away from the hob until it has cooled down and there is no danger of burning.
- ▶ Danger of burning. Do not store anything which might arouse a child's interest in storage areas above or behind the hob. Otherwise they could be tempted to climb onto the hob.
- ▶ Risk of burning and scalding. Place pots and pans on the cooking zone in such a way that children cannot pull them down and burn themselves.
- ▶ Danger of suffocation. Packaging, e.g. plastic wrappings, must be kept out of the reach of babies and children. Whilst playing, children could become entangled in packaging or pull it over their head and suffocate.
- ▶ Activate the system lock to ensure that children cannot switch on the hob inadvertently. Use the safety lock when the hob is in use to prevent children from altering the settings selected.

Technical safety

- ▶ Unauthorised installation, maintenance and repairs can cause considerable danger for the user. Installation, maintenance and repairs must only be carried out by your Miele dealer.
- ▶ Damage to the hob can compromise your safety. Check the hob for visible signs of damage. Do not use the hob if it is damaged.
- ▶ Temporary or permanent operation on an autonomous power supply system or a power supply system that is not synchronised with the mains power supply (e.g. island networks, back-up systems) is possible. A prerequisite for operation is that the power supply system complies with the specifications of EN 50160 or an equivalent standard.

The function and operation of the protective measures provided in the domestic electrical installation and in this Miele product must also be maintained in isolated operation or in operation that is not synchronised with the mains power supply, or these measures must be replaced by equivalent measures in the installation. As described, for example, in the current version of BS OHSAS 18001–2 ISO 45001.

- ▶ The electrical safety of this hob can only be guaranteed when correctly earthed. It is essential that this standard safety requirement is met. If in any doubt please have the electrical installation tested by a qualified electrician.
- ▶ To avoid the risk of damage to the hob, make sure that the connection data on the data plate (voltage and frequency) match the mains electricity supply before connecting it to the mains. Consult a qualified electrician if in doubt.
- ▶ Do not connect the hob to the mains electrical supply by a multi-socket adapter or extension lead. These are a fire hazard and do not guarantee the required safety of the appliance.
- ▶ For safety reasons, this hob may only be used after it has been built in.

Warning and Safety instructions

- ▶ This hob must not be used in a non-stationary location (e.g. on a ship).
- ▶ Never open the casing of the hob.
Touching or tampering with electrical connections or components and mechanical parts is highly dangerous to the user and can cause operational faults.
- ▶ While the hob is under warranty, repairs should only be undertaken by your Miele dealer. Otherwise the warranty is invalidated.
- ▶ Miele can only guarantee the safety of the appliance when genuine original Miele replacement parts are used. Faulty components must only be replaced by Miele spare parts.
- ▶ The hob is not intended for use with an external timer switch or a remote control system.
- ▶ The hob must be connected to the electricity supply by a qualified electrician (see “Installation – Electrical connection”).
- ▶ If the mains connection cable is damaged, it must be replaced with a special mains connection cable by a qualified electrician (see “Electrical connection” in the “Installation” chapter).

Warning and Safety instructions

- ▶ The hob must be disconnected from the mains electricity supply during installation, maintenance and repair work. Ensure that power is not supplied to the appliance until after it has been installed or until any maintenance or repair work has been carried out.
- ▶ Danger of electric shock. Do not use the hob if it is faulty, or if the ceramic surface is cracked, chipped or damaged in any way. Switch it off immediately, disconnect it from the mains electricity supply and contact your Miele dealer.
- ▶ If the hob is installed behind a cabinet door, do not close the door while the hob is in use. Heat and moisture can build up behind the closed door. This can result in damage to the hob, the housing unit and the floor. Do not close the door until the residual heat indicators go out.
- ▶ In areas which may be subject to infestation by cockroaches or other vermin, pay particular attention to keeping the appliance and its surroundings clean at all times. Any damage caused by cockroaches or other vermin will not be covered by the warranty.

Warning and Safety instructions

Correct use

- ▶ The hob gets hot when in use and remains hot for a while after being switched off. There is a danger of burning until the residual heat indicators go out.
- ▶ Oil and fat can overheat and catch fire. Do not leave the hob unattended when cooking with oil and fat. If it does ignite do not attempt to put the flames out with water. Disconnect the hob from the mains and use a suitable fire blanket, saucepan lid, damp towel or similar to smother the flames.
- ▶ Do not leave the hob unattended whilst it is being used. It should be continually monitored whilst boiling and flash frying.
- ▶ Flames could set the grease filters of a cooker hood on fire. Do not flambé under a cooker hood.
- ▶ Spray canisters, aerosols and other inflammable substances can ignite when heated. Therefore do not store such items or substances in a drawer under the hob. Cutlery inserts must be heat-resistant.
- ▶ Do not heat an empty pan.
- ▶ Do not heat up food in closed containers e.g. tins or sealed jars on the hob, as pressure can build up in the container, causing it to explode.
- ▶ Do not cover the hob, e.g. with a hob cover, a cloth or protective foil. The material could catch fire, shatter or melt if the hob is switched on by mistake or if residual heat is still present.
- ▶ When the appliance is switched on either deliberately or by mistake, or when there is residual heat present, there is the risk of any metal items left on the hob heating up, with the danger of burning. Depending on the material, other items left on the hob could also melt or catch fire. Damp pan lids might adhere to the ceramic surface and be difficult to dislodge. Do not use the appliance as a resting place. Switch the cooking zones off after use.

Warning and Safety instructions

- ▶ You could burn yourself on the hot hob. Protect your hands with heat-resistant pot holders or gloves when handling hot pots and pans. Do not let them get wet or damp, as this causes heat to transfer through the material more quickly with the risk of scalding or burning yourself.
- ▶ When using an electrical appliance, e.g. a hand-held food blender, near the hob, ensure that the cable of the electrical appliance cannot come into contact with the hot hob. The insulation on the cable could become damaged.
- ▶ Grains of salt, sugar and sand (e.g. from cleaning vegetables) can cause scratches if they get under pan bases. Make sure that the ceramic surface is clean before placing pans on it.
- ▶ Even a light object can cause damage in certain circumstances. Do not drop anything on the ceramic surface.
- ▶ Placing hot pans on the sensors and indicators could damage the electronics underneath. Do not place hot pans on the sensors or indicators.
- ▶ Do not allow solid or liquid sugar, or pieces of plastic or aluminium foil to get onto the hob when it is hot, as they can damage the ceramic surface when it cools down. If this should occur, switch off the appliance and scrape off all the sugar, plastic or aluminium residues whilst still hot, using a shielded scraper blade suitable for use on glass. Wear oven gloves when doing this. Allow the ceramic surface to cool down and then clean it with a suitable ceramic hob cleaning agent.
- ▶ Pans which boil dry can cause damage to the ceramic glass. Do not leave the hob unattended whilst it is being used.
- ▶ Only use pots and pans with smooth bases. Rough bases will scratch the ceramic glass.
- ▶ Lift pans into position on the hob. Sliding them into place can cause scuffs and scratches.

Warning and Safety instructions

- ▶ Because induction heating works so quickly, the base of the pan could, under certain circumstances, heat up to the temperature at which oil or fat self-ignites within a very short time. Never leave the hob unattended during use!
- ▶ Heat oil or fat for a maximum of one minute. Never use the Booster function to heat oil or fat.
- ▶ For people fitted with a heart pacemaker: Please note that the area immediately surrounding the hob is electromagnetically charged. It is very unlikely to affect a pacemaker. However, if in any doubt, consult the manufacturer of the pacemaker or your doctor.
- ▶ To prevent damage to items which are susceptible to electromagnetic fields, e.g. credit cards, digital storage devices, pocket calculators, etc, do not leave them in the immediate vicinity of the hob.
- ▶ Metal utensils stored in a drawer under the hob can become hot if the appliance is used intensively for a long time.
- ▶ If a drawer is fitted directly underneath the hob, do not store any pointed or small items, paper, serviettes, etc. in the drawer. They could get in through the ventilation slots or be sucked into the casing by the fan and damage the fan or impair cooling.
- ▶ Never use two pans on a cooking zone, extended zone or PowerFlex zone at the same time.
- ▶ If the cookware only partially covers a cooking or extended zone, the handle could become very hot.
Always place cookware in the middle of a cooking or extended zone!
- ▶ The induction generators could be damaged or even destroyed if you use an induction adapter plate for cookware. Do not use induction adapter plates.

Cleaning and care

- ▶ Do not use a steam cleaning appliance to clean this hob. The steam could reach electrical components and cause a short circuit.
- ▶ If the hob is built in over a pyrolytic oven, the hob should not be used whilst the pyrolytic process is being carried out, as this could trigger the overheating protection mechanism on the hob (see relevant section).
- ▶ Miele will guarantee to supply functional spare parts for a minimum of 10 years and up to 15 years following the discontinuation of your hob.

Caring for the environment

Disposing of the packaging material

The packaging material is used for handling and protects the appliance from transport damage. The packaging material used is selected from materials which are environmentally friendly for disposal and can generally be recycled.

Recycling the packaging material reduces the use of raw materials. Use material-specific collection points for valuable materials and take advantage of return options. Your Miele dealer will take the packaging material away.

Disposal of your old appliance

Electrical and electronic appliances often contain valuable materials. They also contain materials which, if handled or disposed of incorrectly, could be potentially hazardous to human health and to the environment. They are, however, essential for the correct functioning of your appliance. Please do not therefore dispose of it with your household waste.

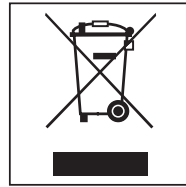

Please dispose of it at your local community waste collection / recycling centre or contact your Miele dealer for advice.

Ensure that it presents no danger to children while being stored for disposal.

Hob

KM 7679 FR, KM 7679 FL, KM 7879 FL

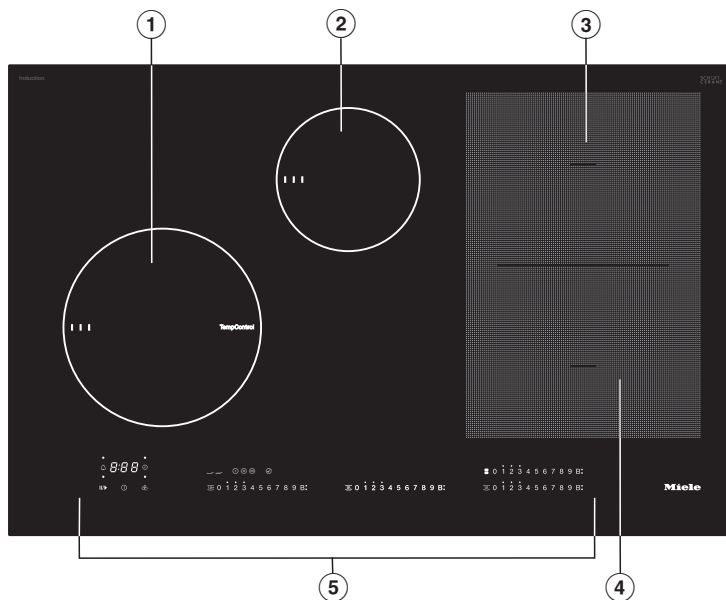

- ① Cooking zone with TwinBooster and TempControl*
- ② Cooking zone with TwinBooster
- ③ PowerFlex cooking zone with TwinBooster
can be combined with PowerFlex cooking zone ④ to form PowerFlex cooking area
- ④ PowerFlex cooking zone with TwinBooster
- ⑤ Controls and indicators

* On some hobs the ceramic surface in the middle of the cooking zone with TempControl is transparent and the temperature sensor is visible.

Guide to the appliance

KM 7629 FX, KM 7699 FR, KM 7899 FL

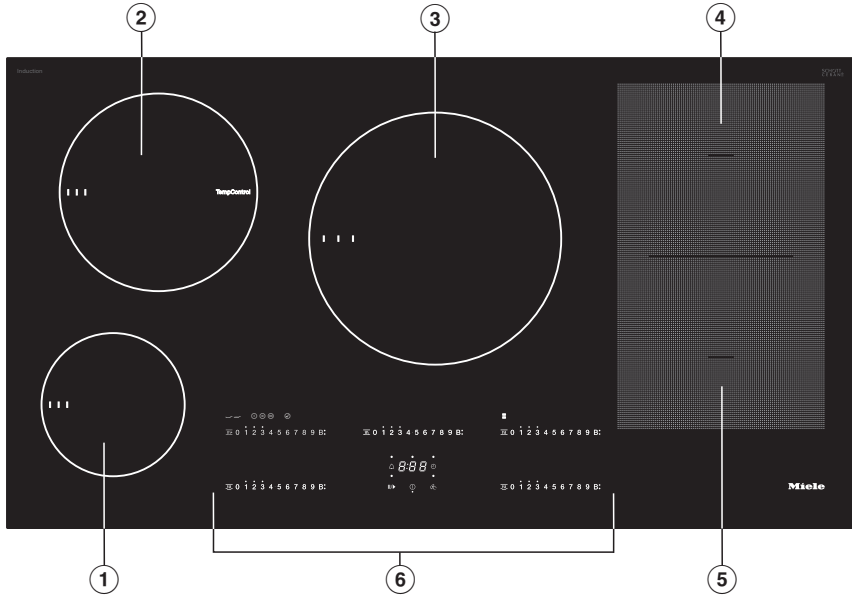

- ① Cooking zone with TwinBooster
- ② Cooking zone with TwinBooster and TempControl*
- ③ Cooking zone with TwinBooster
- ④ PowerFlex cooking zone with TwinBooster
can be combined with PowerFlex cooking zone ⑤ to form PowerFlex cooking area
- ⑤ PowerFlex cooking zone with TwinBooster
- ⑥ Controls and indicators

* On some hobs the ceramic surface in the middle of the cooking zone with TempControl is transparent and the temperature sensor is visible.

KM 7689 FL

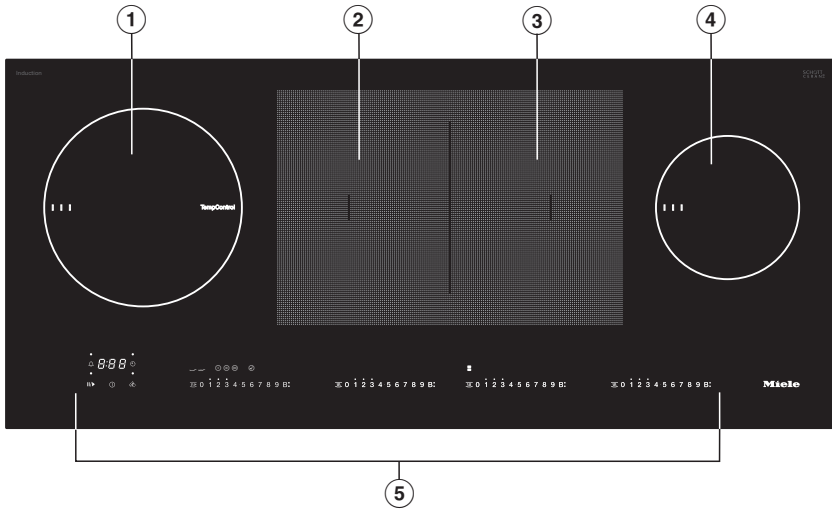

- ① Cooking zone with TwinBooster and TempControl*
- ② PowerFlex cooking zone with TwinBooster
- ③ PowerFlex cooking zone with TwinBooster
can be combined with PowerFlex cooking zone ② to form PowerFlex cooking area
- ④ Cooking zone with TwinBooster
- ⑤ Controls and indicators

* On some hobs the ceramic surface in the middle of the cooking zone with TempControl is transparent and the temperature sensor is visible.

Guide to the appliance

Controls and display

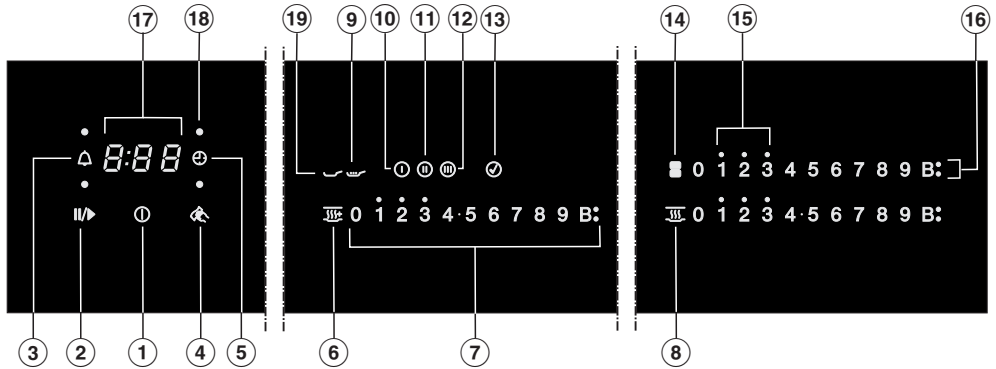

Sensor controls

- ① Hob On/Off
- ② Stop & Go
To stop/start a cooking process in progress
- ③ Minute minder
- ④ Wipe protection
To lock the sensor controls
- ⑤ Auto switch off
Switches the cooking zones off automatically
- ⑥ Keeping warm Plus
(only for cooking zones with TempControl)
For activating/deactivating the Keeping warm Plus function
- ⑦ Numerical display
 - To set the power level
 - To set the times
- ⑧ Keeping warm
To activate/deactivate the Keeping warm function
- ⑨ Simmer setting
(only for cooking zones with TempControl)
- ⑩ Frying level I
(only for cooking zones with TempControl)
- ⑪ Frying level II
(only for cooking zones with TempControl)

- ⑫ Frying level III
(only for cooking zones with TempControl)
- ⑬ CookAssist
(only for cooking zones with TempControl)
For enabling CookAssist actions
- ⑭ PowerFlex cooking zones
For manual connection/disconnection of PowerFlex cooking zones

Displays/indicator lights

- ⑮ Residual heat
- ⑯ Booster function
Booster function is activated
- ⑰ Timer display
 - 0:00* to Time
 - 9:59*
 - LOC* System lock/safety lock is activated
 - dE* Demo mode is activated
- ⑱ Cooking zone allocation auto switch off
Auto switch off for the cooking zone is activated
- ⑲ Cooking zone with TempControl

Guide to the appliance

Cooking zones

KM 7679 FR, KM 7679 FL, KM 7879 FL					
Cooking zone	Size in cm		Max. rating in watts for 230 V ³		Linked cooking zone ⁴
	∅ ¹	 ²			
①	16–22	–	Normal	2300	④
			TwinBooster, level 1	3000	
			TwinBooster, level 2	3650	
②	10–16	–	Normal	1400	③
			TwinBooster, level 1	1700	
			TwinBooster, level 2	2200	
③	15–23	19 x 23	Normal	2100	②
			TwinBooster, level 1	3000	
			TwinBooster, level 2	3650	
④	15–23	19 x 23	Normal	2100	①
			TwinBooster, level 1	3000	
			TwinBooster, level 2	3650	
③ + ④	22–23	23 x 39	Normal	3400	–
			TwinBooster, level 1	4800	
			TwinBooster, level 2	7300	
			Total	7300	

¹ Cookware with a base diameter within the given range may be used.

² The given range corresponds to the maximum base surface of the cookware that may be used.

³ The power given may vary depending on the size and material of the cookware used.

⁴ The cooking zone is linked to this cooking zone electrically so that the rating can be increased; see “Operation – Power management”.

Guide to the appliance

KM 7629 FX, KM 7699 FR, KM 7899 FL					
Cooking zone	Size in cm		Max. rating in watts for 230 V ³	Linked cooking zone ⁴	
	∅ ¹	 ²			
①	10–16	–	Normal TwinBooster, level 1 TwinBooster, level 2	1400 1700 2200	②
②	16–22	–	Normal TwinBooster, level 1 TwinBooster, level 2	2300 3000 3650	①
③	18–28	–	Normal TwinBooster, level 1 TwinBooster, level 2	2600 3000 3650	④
④	15–23	19 x 23	Normal TwinBooster, level 1 TwinBooster, level 2	2100 3000 3650	③
⑤	15–23	19 x 23	Normal TwinBooster, level 1 TwinBooster, level 2	2100 3000 3650	–
④ + ⑤	22–23	23 x 39	Normal TwinBooster, level 1 TwinBooster, level 2	3400 4800 7300	–
			Total	11,000	

¹ Cookware with a base diameter within the given range may be used.

² The given range corresponds to the maximum base surface of the cookware that may be used.

³ The power given may vary depending on the size and material of the cookware used.

⁴ The cooking zone is linked to this cooking zone electrically so that the rating can be increased; see “Operation – Power management”.

Guide to the appliance

KM 7689 FL					
Cooking zone	Size in cm		Max. rating in watts for 230 V ³		Linked cooking zone ⁴
	∅ ¹	 ²			
①	16–22	–	Normal	2300	③
			TwinBooster, level 1	3000	
			TwinBooster, level 2	3650	
②	15–23	19 x 23	Normal	2100	④
			TwinBooster, level 1	3000	
			TwinBooster, level 2	3650	
③	15–23	19 x 23	Normal	2100	①
			TwinBooster, level 1	3000	
			TwinBooster, level 2	3650	
④	10–16	–	Normal	1400	②
			TwinBooster, level 1	1700	
			TwinBooster, level 2	2200	
② + ③	22–23	23 x 39	Normal	3400	–
			TwinBooster, level 1	4800	
			TwinBooster, level 2	7300	
			Total	7300	

¹ Cookware with a base diameter within the given range may be used.

² The given range corresponds to the maximum base surface of the cookware that may be used.

³ The power given may vary depending on the size and material of the cookware used.

⁴ The cooking zone is linked to this cooking zone electrically so that the rating can be increased; see “Operation – Power management”.

Before using for the first time

- Please stick the extra data plate for the appliance supplied with this documentation in the space provided in the “After sales service” section of this booklet.
- Remove any protective wrapping and stickers.

Cleaning the hob for the first time

- Before using for the first time, clean the hob with a damp cloth only and then wipe dry.

Switching on the hob for the first time

The metal components have a protective coating which may give off a slight smell when heated up for the first time. The induction coils may also give off a slight smell for the first few hours of operation. This smell will be less noticeable with each subsequent use before dissipating completely.

The smell and any vapours given off do not indicate a faulty connection or appliance and they are not hazardous to health.

Please note that the heating up time on induction hobs is very much shorter than on conventional hobs.

Before using for the first time

Miele@home

Prerequisite: home WiFi network

Your hob is equipped with an integrated WiFi module. The hob can be connected to your home WiFi network.

If your Miele cooker hood is also connected to the home WiFi network, you can control the cooker hood automatically with the Con@ctivity function. Further information can be found in the operating and installation instructions for your cooker hood.

Make sure that the signal of your WiFi network is sufficiently strong in the place where your hob is installed.

There are a number of ways of connecting your hob to your WiFi network.

The hob requires max. 2 W in networked standby.

Availability of the WiFi connection

The WiFi connection shares a frequency range with other appliances (including microwave ovens and remote control toys). This can give rise to sporadic or even complete connection failures. Therefore, the availability of featured functions cannot be guaranteed.

Miele@home availability

The ability to use the Miele app depends on the availability of the Miele@home service in your country.

The Miele@home service is not available in every country.

For information about availability, please visit www.miele.com.

Miele App

The Miele App is available to download free of charge from the Apple App Store[®] or from the Google Play Store[™].



After installing the Miele app on a mobile device, you can do the following:

- Call up information on the operating status of your hob
- Call up information on the programme sequence of your hob
- Set up a Miele@home network with other WiFi-enabled Miele appliances

Before using for the first time

Setting up Miele@home

Connecting via the app

The Miele app can be used to connect to your network.

- Install the Miele app on your mobile device.

To connect, you will need:

1. Your WiFi network password
2. The password for your hob

The password for your hob consists of the last 9 digits of the serial number. This can be found on the appliance's data plate.

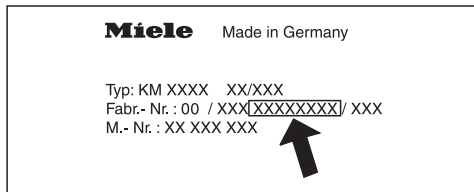

- Switch the hob on.
- Start the Miele app.
- Touch the 0 sensor control on any of the numerical displays.
- Touch the 0 and 5 sensor controls at the same time for 6 seconds.

The seconds can be seen counting down in the timer display. After the time has elapsed, the code C:07 is displayed in the timer display for 10 seconds.

You now have 10 minutes to configure the WiFi.

- Follow the user navigation in the app.

Connecting via WPS

Prerequisite: you must have a WPS (WiFi protected setup) compatible router.

- Switch the hob on.
- Touch the 0 sensor control on any of the numerical displays.
- Touch the 0 and 6 sensor controls at the same time for 6 seconds.

The seconds can be seen counting down in the timer display. After the time has elapsed, a progress light appears in the timer display during the connection attempt (for max. 120 seconds).

The WPS login is only active during these 120 seconds.

- Activate the WPS function on your WiFi router.

If the connection was successful, the code C:02 appears in the timer display. If the connection could not be established, the timer display will show the code C:07 . You have probably not activated WPS on your router quickly enough. Repeat the steps above.

Tip: If your WiFi router does not support WPS, please connect via the Miele app.

Before using for the first time

Canceling the process

- Touch any sensor control.

Resetting settings

Resetting is not required when replacing the router.

- Switch the hob on.
- Touch the 0 sensor control on any of the numerical displays.
- Touch the 0 and 9 sensor controls at the same time for 6 seconds.

The seconds can be seen counting down in the timer display. After the time has elapsed, the code `C:00` is displayed in the timer display for 10 seconds.

Reset the settings if you are disposing of your hob, selling it or putting a used hob into operation. This is the only way to ensure that all personal data has been removed and the previous owner will no longer be able to access the hob.

Con@ctivity

Con@ctivity is the direct communication system between your hob and a Miele cooker hood. Con@ctivity enables the cooker hood to operate automatically depending on the operating status of a hob.

Further information can be found in the operating and installation instructions for your cooker hood.

The hob requires max. 2 W in networked standby.

Availability of the WiFi connection

The WiFi connection shares a frequency range with other appliances (including microwave ovens and remote control toys). This can give rise to sporadic or even complete connection failures. Therefore, the availability of featured functions cannot be guaranteed.

Setting up Con@ctivity

You can set up Con@ctivity between the hob and cooker hood using your home WiFi network or a direct WiFi connection.

Con@ctivity via the home WiFi network (Con@ctivity 3.0)

Requirements:

- Home WiFi network
- WiFi-enabled Miele cooker hood

- Connect the cooker hood and the hob to your home WiFi network (see “Before using for the first time – Miele@home”).

The Con@ctivity function will be activated automatically.

You can find the necessary information on connecting the cooker hood in the associated operating and installation instructions.

Before using for the first time

Con@ctivity via a direct WiFi connection (Con@ctivity 3.0)

You can find the necessary information on connecting the cooker hood in the associated operating and installation instructions.

- Switch the hob on.
- Touch the 0 sensor control on any of the numerical displays.
- Touch and hold the 0 and 7 sensor controls on the numerical display at the same time for 6 seconds.

The seconds can be seen counting down in the timer display. After the time has elapsed, a progress light appears during the connection attempt. If the connection was successful, the code `C:02` appears in the timer display. If the connection could not be established, the timer display will show the code `C:01`. Repeat the steps above.

When successfully connected, **2** and **3** will light up constantly on the cooker hood.

- Quit connection mode on the cooker hood by pressing the run-on  button.

Con@ctivity is now activated.

With a direct WiFi connection, it is not possible to connect the hob and the cooker hood to a home network. If this is desired later, the direct WiFi connection between the hob and the cooker hood must first be reset (see “Initial commissioning – Con@ctivity” and “Disconnecting the WiFi” in the operating and installation instructions for the cooker hood).

Cancelling the process

- Touch any sensor control.

Resetting settings

Resetting is not required when replacing the router.

- Switch the hob on.
- Touch the 0 sensor control on any of the numerical displays.
- Touch the 0 and 9 sensor controls at the same time for 6 seconds.

The seconds can be seen counting down in the timer display. After the time has elapsed, the code `C:00` is displayed in the timer display for 10 seconds.

Reset the settings if you are disposing of your hob, selling it or putting a used hob into operation. This is the only way to ensure that all personal data has been removed and the previous owner will no longer be able to access the hob.

An induction coil is located under each induction cooking zone. The coil creates a magnetic field that reacts directly with the base of the pan and heats it up. The cooking zone itself is heated up indirectly by the heat given off by the pan.

An induction cooking zone only works when cookware with a magnetic base is placed on it (see “Cookware”). Induction automatically recognises the size of the cookware.



Risk of burning due to hot items.

When the appliance is switched on either deliberately or by mistake, or when there is residual heat present, there is the risk of metal items placed on the hob heating up.

Do not use the appliance as a resting place for anything.

After use, switch the hob off with the ① sensor control.

Noises

When using an induction hob, the following noises can occur in the pan, depending on what it is made of and how it has been constructed.

Buzzing on the higher power settings. This will decrease or cease altogether when the power setting is reduced.

If the pan base is made of layers of different materials (e.g. in a sandwiched base), it might emit a crackling sound.

Whistling might occur if linked zones (see “Operation - Booster”) are being used at the same time, and the pans also have bases made of layers of different materials.

You might hear a clicking sound from the electronic switches, especially on lower settings.

A whirring sound, when the cooling fan comes on. This switches on to protect the electronics when the hob is being used intensively. The cooling fan may continue to run after the appliance has been switched off.

How it works

Power management

The hob has a maximum total permitted power consumption which cannot be exceeded for safety reasons.

Cooking zones can be linked together in pairs on the hob. This allows additional power to be transferred from one cooking zone to another.

The previously set setting has precedence and the hob will operate with this level.

If power is transferred from one cooking zone to the linked cooking zone, the power for the first cooking zone must be reduced.

The possible values for the maximum total permitted power consumption and which cooking zones are linked together can be found in “Overview – Cooking zone data”.

If the new cooking zone requires more power than the first cooking zone can provide, this may result in the following consequences for the first cooking zone:

- The power level is reduced.
- Auto heat-up is deactivated. Cooking continues at the set level. If the power is not sufficient, the power level will be reduced again.
- The Booster function is deactivated.
- The cooking zone is switched off.

If the most recently set power level is reduced or the Booster function is switched off, the power level for the linked cooking zone can be increased again.

Suitable pans

- stainless steel pans with a magnetic base
- enamelled steel pans
- cast iron pans

Please be aware that the properties of the pan base can affect the evenness with which the food heats up (e.g. when making pancakes). The base of the pan must be able to distribute the heat evenly. A sandwich base made of stainless steel is particularly suitable.

Unsuitable pans.

- stainless steel pans without a magnetic base
- aluminium or copper pans
- glass, ceramic or earthenware pots and pans

Testing pans

To test whether a pan is induction-compatible, hold a magnet to the base of the pan. If the magnet sticks, the pan is generally suitable.

No pan/unsuitable pan display

The set power level flashes in the numerical keybank for the cooking zone

- if the zone has been switched on without a pan in place, or if the pan is unsuitable (non-magnetic base)
- if the diameter of the base of the pan is too small
- if the pan is taken off the cooking zone when it is switched on

If a suitable pan is placed on the cooking zone within 3 minutes, the flashing power level will go out and you can continue as normal.

If no pan or an unsuitable pan is placed on the cooking zone, the cooking zone will switch off automatically after 3 minutes.

Pans

Tips

- To make optimum use of the cooking zones, choose cookware with a suitable base diameter (see “Overview – Cooking zone data”). If the pan is too small it will not be recognised.
 - Position the cookware as centrally as possible on the relevant cooking zone/cooking area.
 - Use only pots and pans with smooth bases. Rough bases can scratch the ceramic glass.
 - Always lift cookware to move it. This will help prevent scratching. If any scratches do appear as a result of cookware being pushed around, this will not affect the function of the hob. These scratches are normal signs of use and are not grounds for making a complaint.
- Please note that the maximum diameter quoted by manufacturers often refers to the diameter of the top rim of the pots and pans. The diameter of the base (generally smaller) is more important.

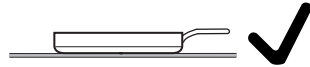

- Where possible, use pans with vertically straight sides. If a pan has angular sides, induction also acts on the sides of the pan. The sides of the pan may discolour or the coating may peel off.

Tips on saving energy

- Use a lid whenever possible to minimise heat loss.
- Select a smaller pan when cooking small quantities. A smaller pan uses less energy than a larger pan with very little in it.
- Cook with as little water as possible.
- Once food has come to the boil or the oil in the pan is hot enough for frying, reduce the heat to a lower setting.
- Use a pressure cooker to reduce cooking times.

Setting range

The hob is programmed with 9 power levels at the factory. If you wish to fine-tune a setting, you can extend the power setting range to 17 power levels (see “Programming”).

	Setting range	
	Default setting (9 power levels)	Extended settings (17 power levels)
Melting butter Dissolving gelatine Melting chocolate	1–2	1–2.
Making milk puddings	2	2–2.
Warming small quantities of liquid Cooking rice	3	3–3.
Defrosting frozen vegetables	3	2.–3
Making porridge	3	2.–3.
Warming liquid and semi-solid foods Making omelettes or lightly frying eggs Steaming fruit	4	4–4.
Cooking dumplings	4	4–5.
Steaming vegetables and fish	5	5
Defrosting and reheating frozen food	5	5–5.
Gently frying eggs (without overheating the fat)	6	5.–6.
Bringing large quantities of food to the boil, e.g. casseroles. Thickening custard and sauces, e.g. hollandaise	6–7	6.–7
Gently frying meat, fish and sausages (without overheating the fat)	6–7	6.–7.
Frying pancakes, potato fritters etc.	7	6.–7
Braising meat	8	8–8.
Boiling large quantities of water Bringing to the boil	9	9

These settings should only be taken as a guide. The power of the induction coils will vary depending on the size and material of the pan. For this reason, it is possible that the settings will need to be adjusted slightly to suit your pans. As you use the hob, you will get to know which settings suit your pans best. When using new pans that you are not familiar with, set the power level below the one specified. Please refer to “TempControl” for the settings for frying using TempControl.

Using the appliance

This ceramic hob is equipped with electronic sensor controls which react to finger contact. For safety reasons, in order to switch the appliance on, the On/Off ① sensor needs to be touched for a little longer than the other sensors. Each time a sensor control is activated, an audible signal sounds.

Only the printed On/Off ① symbol is visible when the hob is switched off. More sensors light up when the hob is switched on.

 Malfunction due to dirty and/or covered sensor controls.

If the sensor controls are dirty or covered, this could cause them to fail to react, to activate a function or even to switch the appliance off automatically (see “Safety features – Safety switch-off”). Placing hot cookware on the sensor controls/ indicators can damage the electronic unit underneath.

Keep the sensor controls and indicators clean.

Do not place anything over the sensor controls or indicators.

Do not place hot cookware over the sensor controls or indicators.



①

① Sensor controls and indicators

Operation

 Risk of fire with overheated food. Unattended food can overheat and catch alight. Do not leave the hob unattended whilst it is being used.

Please note that the heating up time on induction hobs is very much shorter than on conventional hobs.

Switching on the hob

- Touch the ① sensor.

Other sensors will light up.

If no further entry is made, the hob will switch itself off after a few seconds for safety reasons.

Setting the power level

Permanent pan recognition is activated as standard (see “Programming”). When the hob is switched on and you place a pan on one of the cooking zones, all the sensors for that cooking zone's numerical keybank will light up.

- Place a pan on the cooking zone you want to use.
- Touch the appropriate number sensor for the power level you want.

Switching off a cooking zone

- To switch off a cooking zone, touch the 0 sensor for that cooking zone.
- To switch off the hob and all the cooking zones, touch the ① sensor.

Residual heat indicator

If the cooking zone is still hot, the residual heat indicator will light up after the zone has been switched off. Depending on the temperature, a dot will appear above power levels 1, 2 and 3.

The dots of the residual heat indicator will go out one after another as the cooking zone cools down. The last dot only goes out when the cooking zone is safe to touch.

 Risk of burning due to hot cooking zones.

The cooking zones will be hot after use.

Do not touch the cooking zones while the residual heat indicators are on.



TempControl

TempControl is used to obtain and maintain the ideal temperature for the food being cooked so that the power levels do not need to be adjusted manually. A sensor under the cooking zone measures the temperature under the ceramic glass and the pan. The sensor regulates the cooking zone power level so that the temperature remains constant:

- The fat cannot overheat.
- The power levels do not need to be adjusted manually.
- It is not necessary to turn the food being fried frequently.

Depending on the hob model, the sensor will be visible in the centre of the cooking zone.

There are 3 frying levels and a simmer setting.

Once the corresponding temperature for the frying level has been reached, the sensor control for the simmer setting  will appear. The simmer setting  is used for cooking at low heat, e.g. for reducing sauce. The simmer setting can be set to follow a frying process. Touch the sensor control to activate the simmer setting.

TempControl is not suitable for deep fat frying and boiling.
Use this function for normal frying only.

Notes on use

- Make sure that the ceramic surface is kept clean, particularly in the area of the sensor in the middle of the cooking zone.
- Use pans which distribute heat evenly, e.g. pans with a sandwich base.
- For frying with butter, use frying level ① only.
- Do not place the food in the pan until the pre-set temperature has been reached.
- You can switch from one frying level to another.
- TempControl will deactivate if you switch from a frying level to a power level.
- You can carry out several frying processes one after the other. The cooking zone does not need to cool down.
- So that simmering takes place reliably, at least 250 ml of liquid which is not too thick needs to be added.
- You can switch from the simmer setting back to a frying level.

Operation

Activating TempControl

- Place a pan on the cooking zone and add frying fat/oil if necessary.
- Touch the sensor control for the frying level you want to use (ⓘ, ⓘ, ⓘ).

The sensor control for the frying level selected will start to pulsate.

Once the pre-set temperature for the frying level selected has been reached:

- A signal sounds.
 - The sensor control lights up constantly.
 - The simmer setting sensor control  lights up.
- Place the food in the frying pan.

Simmer setting

If you want to cook on low heat following the frying process, select the simmer setting.

- Touch the simmer setting sensor control  and add at least 250 ml of liquid.

Frying assistant cooking table

Simmer setting ①
For reducing sauces

Frying level ①
Fried eggs, scrambled eggs
Chicken breast
Frozen spring rolls
Frozen fish fingers
Fish fillet/whole fish
Kebabs
Vegetables in butter (mushrooms, garlic)
Schupfnudeln (potato noodles) in butter
Meat patties

Frying level ②
Potato pancakes
Pancakes
Fried potatoes made from raw potatoes
Meat loaf
Steaks
Escalopes
Tortilla
Langos (Hungarian flatbread)
Popcorn
Frozen stir-fried dishes
Dry-roasting seeds
Prawns
Bratwurst
Caramel
Sliced meat

Frying level ③
Cooking with a wok
Fried potatoes made from cooked potatoes
Searing meat for stews (e.g. goulash)
Searing large quantities of meat

Operation

Power level setting - Extended setting range

- Touch the numerical keybank in between two number sensors.

The numbers to the left and right of the interim level light up brighter than the others.

Example:

If you have set power level 7, the numbers 7 and 8 will be brighter than the other numbers.

PowerFlex cooking area

The PowerFlex cooking zones combine automatically to form a PowerFlex cooking area when you place sufficiently large items of cookware on them (see “Guide to the appliance – Hob”). Settings for the linked cooking area are controlled by the numerical display of the front or left PowerFlex cooking zone (depending on model). The PowerFlex cooking zones can also be switched on and off manually:

- Touch the  sensor control.

Positioning cookware

Refer to the cooking zone data for your hob model for information about cookware sizes and the corresponding positions (see “Overview – Cooking zone data”).

PowerFlex cooking zone

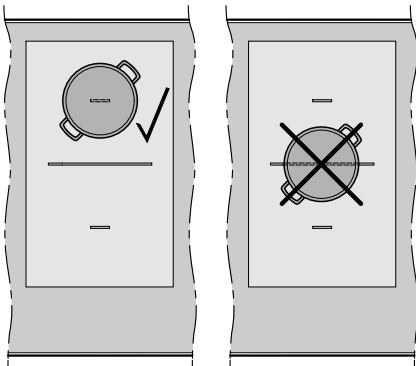

PowerFlex cooking area (pot)

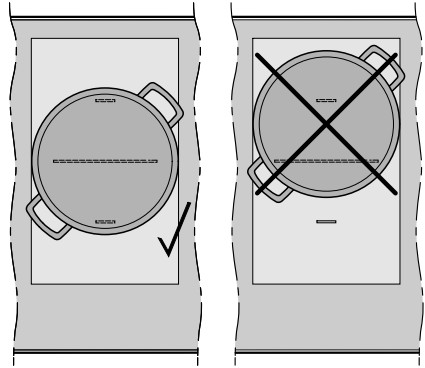

PowerFlex cooking area (oven dish)

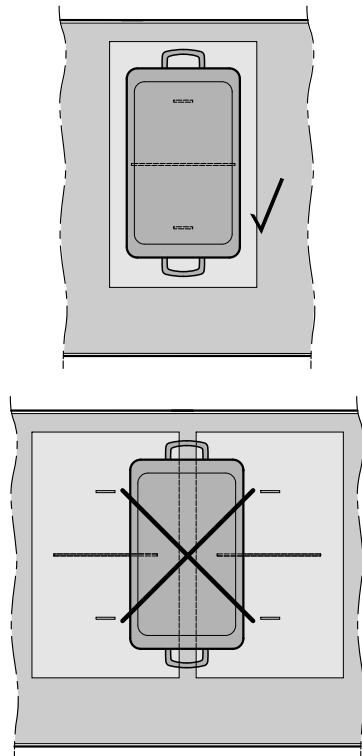

Operation

Auto heat-up

When Auto heat-up has been activated, the cooking zone switches on automatically at the highest setting and then switches to the continued cooking setting which you have previously selected. The heat-up time depends on which continued cooking setting has been chosen (see chart).

Activating Auto heat-up

- Touch the sensor for the continued cooking setting you want until a tone sounds and the sensor starts to pulsate.

During the heat-up time (see chart), the continued cooking level set will pulsate. With extended power levels (see “Programming”), the sensors for the power levels in front of and after the interim power level will pulsate if an extended power level setting has been selected.

Altering the continued cooking setting will deactivate Auto heat-up.

Deactivating Auto heat-up

- Touch the sensor for the continued cooking setting.

or

- Set another power level.

Continued cooking setting*	Heat-up time [min : sec]
1	Approx. 0:15
1.	Approx. 0:15
2	Approx. 0:15
2.	Approx. 0:15
3	Approx. 0:25
3.	Approx. 0:25
4	Approx. 0:50
4.	Approx. 0:50
5	Approx. 2:00
5.	Approx. 5:50
6	Approx. 5:50
6.	Approx. 2:50
7	Approx. 2:50
7.	Approx. 2:50
8	Approx. 2:50
8.	Approx. 2:50
9	–

* The continued cooking settings with a dot after the number are only available if the power level range has been extended (see “Programming”).

Booster function

The cooking zones are equipped with a TwinBooster.

When the Booster function is activated, the power is boosted so that large quantities can be heated up quickly, e.g. when boiling water for cooking pasta. The boost in power is active for a maximum of 15 minutes.

When the Booster function is activated, the settings for active cooking zones may be changed, see "Induction – Power management".

The Booster function can be used on a maximum of 2 cooking zones or 1 PowerFlex cooking area at the same time.

If the Booster function is switched on when

- no power level has been selected, the cooking zone will revert automatically to level 9 at the end of the Booster time or if the Booster function is switched off before this.
- a power level has been selected, the cooking zone will revert automatically to the power level selected at the end of the Booster time or if the Booster function is switched off before this.

Activating the TwinBooster

Level 1

- Place the cookware on the cooking zone you want to use.
- Select a power level if necessary.
- Touch the **B** sensor control.

The indicator light ● for TwinBooster level 1 lights up.

Level 2

- Place the cookware on the cooking zone you want to use.
- Select a power level if necessary.
- Touch the **B** sensor control twice.

The indicator light ● for TwinBooster level 2 lights up.

Deactivating TwinBooster

- Touch the **B** sensor control repeatedly until the indicator lights go out.

or



- Set another power level.

Operation

Keeping warm/Warming food



The Keeping warm  function is for keeping food warm when it has just been cooked and is still hot. It is not for reheating food that has gone cold.

The Keeping warm Plus  function (only for TempControl cooking zones) is for keeping food warm and for warming up food. It is also suitable for melting chocolate.

The maximum duration for the Keep warm  and Keeping warm Plus  functions is 2 hours.

- Only use pans for keeping food warm. Cover the pan with a lid.
- Stir firm or viscous food (mashed potatoes, stew) occasionally.
- Nutrients are lost when food is cooked, and continue to diminish when food is kept warm. The longer food is kept warm, the greater the loss of nutrients. Try to ensure that food is kept warm for as short a time as possible.

Activating/deactivating the Keeping warm function

- Touch the  or  sensor control for the cooking zone you wish to use.

Keeping warm plus keeping warm temperatures

A keeping warm temperature of 85 °C is set as standard. You can change the keeping-warm temperature (see “Programming”).

Use	Temperature °C
Melting chocolate	50–55
Keeping solid food and thick liquids warm	65–75
Keeping clear soups warm	80–90

The cooking result can be negatively affected if food is kept warm at excessively high temperatures. Food can change colour and even spoil.

Enabling CookAssist actions

Requirements:

- Mobile device with latest version of the Miele app (see “Before using for the first time – Miele@home”)
- Hob must be connected to Miele@home

If there is no action in the app that is waiting to be confirmed on the hob, the sensor control will not light up.

- Follow the user navigation in the app.
- If you wish to start an action in the app via the hob, confirm the action in the app.

The  sensor control flashes.

- Touch the  sensor control on the hob.

The  sensor control no longer lights up. The hob starts the action.

If a recipe is started in the app, only the start needs to be confirmed in the app and on the hob. Additional preparation steps can be confirmed either in the app or on the hob.

Timer

The hob has to be switched on if you want to use the timer.

The timer can be used for the following 2 functions:

- For setting the minute minder
- For automatically switching a cooking zone off

You can use the functions simultaneously.

A duration of between 1 minute (0:01) and 9 hours 59 minutes (9:59) can be set.

Durations of up to 59 minutes are shown in minutes (00:59) and durations of more than 60 minutes are shown in hours and minutes. Durations are entered in the order of hours, followed by minutes in tens and then units.

Example:

59 minutes = 0:59 hours,

Enter: 5-9

80 minutes = 1:20 hours,

Enter: 1-2-0

After the first number has been entered, the timer display will light up constantly.

After the second number has been entered, the first number will move to the left. After the third number has been entered, the first and second numbers will move to the left.

Minute minder

The minute minder is set using the numerical display for the left or front left cooking zone (depending on model).

Setting the minute minder

- Touch the  sensor control.

The timer display flashes.

- Set the required duration.

Touch the  sensor control or wait 10 seconds to start the minute minder.

Changing the minute minder duration

- Touch the  sensor control.

The timer display flashes.

- Set the required duration.

Deleting the minute minder duration

- Touch the  sensor control.

- Touch the  on the numerical display.

Auto switch off

You can set a time after which a cooking zone will switch off automatically. This function can be used for all cooking zones at the same time.

If the time programmed is longer than the maximum operating time allowed, the cooking zone will be switched off by the safety switch-off function (see “Safety features – Safety switch-off”).

The switch-off time is set on the numerical display for each cooking zone you want to switch off automatically.

Setting the switch-off time

- Select a power level for the cooking zone you require.
- Touch the ⌚ sensor control.

The timer display flashes.

- Set the required duration.

Touch the ⌚ sensor control or wait 10 seconds to start the switch-off time.

The cooking zone allocation auto switch off indicator light pulsates.

- To set a switch-off time for another cooking zone, follow the same steps as described above.

If more than one switch-off time is programmed, the shortest time left will be displayed, and the corresponding indicator light will pulsate. The other indicator lights will light up constantly.

- If you want to show the time left for another cooking zone which is counting down in the background,

touch the ⌚ sensor control repeatedly until the indicator light for the desired cooking zone pulsates.

Changing the switch-off time

- Touch the ⌚ sensor control repeatedly until the indicator light for the cooking zone you require pulsates.

The timer display flashes.

- Set the required duration.

Deleting the switch-off time

- Touch the ⌚ sensor control repeatedly until the indicator light for the cooking zone you require pulsates.



The timer display flashes.

- Touch the  sensor control on the numerical display.

Timer

Using both timer functions at the same time

If you use both functions simultaneously, the shortest time is always displayed. The  sensor control (minute minder) or the indicator light of the cooking zone with the shortest time pulsates.

- Touch the  or  sensor control if you want to show the times left counting down in the background.
- If a switch-off time has been programmed for several cooking zones, touch the  sensor control repeatedly until the indicator light for the required cooking zone pulsates.

Stop & Go

When Stop & Go is activated, the power of all cooking zones in use is reduced to power level 1.

The cooking zone power levels and the timer settings cannot be altered; the hob can only be switched off. The minute minder, switch-off, booster and AutoBoost times continue to run.

When Stop & Go is deactivated, the cooking zones will continue to operate at the power/frying level previously selected.

If the function is not deactivated within 1 hour, the hob will switch off.

Activating/Deactivating

- Touch the II/▶ sensor control.

Recall

If the hob is switched off by mistake during use, this function can be used to reset all settings. For this to work, the hob must be switched on again within 10 seconds of being switched off.

- Switch the hob on again.

The indicators for the power/frying levels previously set will flash.

- Press one of the flashing power or frying level indicators immediately.

All the cooking zones and the timer will continue to operate using the settings selected previously.

Additional functions

Wipe protection

The hob sensors can be locked for 20 s in order, for example, to remove soiling. The ① is not locked.

Activating

- Touch the  sensor.

The time will count down in the timer display.

Deactivating

- Touch the  sensor until the timer display goes out.

Demonstration mode

This function enables the hob to be demonstrated in showrooms without heating up.

Activating / Deactivating

- Switch the hob on.
- Touch the 0 sensor control on any of the numerical keybanks.
- Then touch the 0 and 2 sensors at the same time for 6 seconds.

In the timer display, *dE* flashes alternately with *Dn* (demonstration mode activated) or *OFF* (demonstration mode deactivated) for a few seconds.

Displaying hob data

The model number and software version of the hob can be displayed. There must not be any pots or pans on the cooking zones.

Model number/Serial number

- Switch the hob on.
- Touch the 0 sensor control on any of the numerical keybanks.
- Touch the 0 and 4 sensor controls at the same time.

Numbers will appear in the timer display one after another, separated by a dash.

Example: *12 34* (model number KM 1234) – *1 23 45 67 89* (serial number)

Software version

- Switch the hob on.
- Touch the 0 sensor control on any of the numerical keybanks.
- Touch the 0 and 3 sensor controls at the same time.

Numbers appear in the timer display:

Example: *2:00* = Software version 2.00

System lock/safety lock

Your hob is equipped with a system lock and a safety lock to prevent the hob and the cooking zones being switched on or any settings being altered by mistake.

The **system lock** is activated when the hob is switched off. If the system lock is activated, the hob cannot be switched on and the timer cannot be used. A set minute minder time continues to count down. The hob is programmed so that the system lock must be activated manually. The system lock can be programmed to be activated automatically 5 minutes after the hob has been switched off (see “Programming”).

The **safety lock** is activated when the hob is switched on. When the lock is activated, the hob can be operated only under certain conditions:

- The cooking zones and the hob can only be switched off.
- A set minute minder time can be modified.

If an unavailable sensor control is touched whilst the system lock or safety lock is activated *LDC* will appear in the timer display for few seconds and a tone will sound.

Activating the system lock

- Touch the  sensor for 6 seconds.



The seconds can be seen counting down in the timer display. When this time has elapsed *LDC* will appear in the timer display. The system lock has been activated.

Deactivating the system lock

- Touch the  sensor for 6 seconds.



LDC will appear briefly in the timer display and then the seconds will be seen counting down. The system lock is deactivated once the time has elapsed.

Activating the safety lock

- Touch and hold the  and  sensors at the same time for 6 seconds.

The seconds can be seen counting down in the timer display. When this time has elapsed *LDC* will appear in the timer display. The safety lock is activated.

Deactivating the safety lock

- Touch and hold the  and  sensors at the same time for 6 seconds.

LDC will appear briefly in the timer display and then the seconds will be seen counting down. Once the time has elapsed, the lock function is deactivated.

Safety features

Safety switch-off

Sensor controls are covered

Your hob will turn off automatically if one or several of the sensors remain covered for longer than 10 seconds, for example, by finger contact, food boiling over or by an object such as an oven glove or tea towel. ① flashes briefly above the \mathcal{L} sensor control and a tone will sound.

\mathcal{L} will go out once you have removed the object and/or cleaned the hob and the hob will be ready to use again.

Excessive operating time

The safety switch-off mechanism is triggered automatically if a cooking zone is heated for an unusually long period of time. This time depends on the power level selected. If it has been exceeded, the cooking zone switches off and the residual heat indicator appears. If you switch the cooking zone on and off again, it is ready for operation again.

The hob is programmed to safety setting 0 at the factory. If required you can set a higher safety setting with a shorter maximum operating time (see chart).

Power level*	Maximum operating time [h:min]		
	Safety setting		
	0**	1	2
1	10:00	8:00	5:00
1.	10:00	7:00	4:00
2/2.	5:00	4:00	3:00
3/3.	5:00	3:30	2:00
4/4.	4:00	2:00	1:30
5/5.	4:00	1:30	1:00
6/6.	4:00	1:00	0:30
7/7.	4:00	0:42	0:24
8	4:00	0:30	0:20
8.	4:00	0:30	0:18
9	1:00	0:24	0:10
①, ②, ③	4:00	0:42	0:24

* The power levels with a dot after the number are only available if the power level range has been extended (see “Setting ranges”).

** Factory default setting

Overheating protection

All the induction coils and heat sinks for the electronic module are fitted with an overheating protection mechanism.

Before the induction coils or heat sinks get too hot, the overheating protection mechanism intervenes in one of the following ways:

Induction coils

- Any Booster function in operation will be switched off.
- The set power level will be reduced.
- The cooking zone turns off automatically. *Err* will flash alternately with *044* in the timer display.

You can use the cooking zone again as usual when the fault message has gone out.

Heat sinks

- Any Booster function in operation will be switched off.
- The set power level will be reduced.
- The cooking zones switch off automatically.

The affected cooking zones can only be used again as usual once the cooling element has cooled down to a safe level.

The overheating protection may be activated under the following circumstances:

- The cookware being heated is empty.
- Fat or oil is being heated on a high power level.
- There is insufficient ventilation to the underside of the hob.
- A hot cooking zone is switched back on after an interruption to the power supply.

If, despite removing the cause, the overheating protection mechanism triggers again, contact your Miele dealer.

Programming

You can adapt the programming of the hob to your personal needs. Several settings can be altered in succession.

After accessing programming mode, the ☺ symbol appears and *PC* will appear in the timer display. After a few seconds *P:01* (Programme 01) will flash alternately with *C:01* (Code) in the timer display.

Change programming

Accessing programming mode

The II/▶ sensor is located approx. 1 cm (index finger width) to the left of the ① sensor.

- **With the hob switched off**, touch the ① and II/▶ sensors at the same time until the ☺ symbol and *PC* appear in the timer display.

Setting a programme

For a two digit programme number you need to first set the tens position.

- Whilst the programme is visible in the display (e.g. *P:01*), touch the ☺ sensor repeatedly until the number for the programme you want appears in the display or touch the appropriate number on the numerical keybank.

Setting the code

- Whilst the code is visible in the display (e.g. *C:01*), touch the ☺ sensor repeatedly until the number for the code you want appears in the display or touch the appropriate number on the numerical keybank.

To save the settings

- While the programme is showing in the display (e. g. *P:01*) touch the ① sensor until the indicators go out.

To avoid saving the settings

- While the code is showing in the display (e. g. *C:01*) touch the ① sensor until the indicators go out.

Programming

Programme ¹		Code ²	Settings
P:01	Demo mode	C:00	Demo mode off
		C:01	Demo mode on ³
P:03	Factory default setting	C:00	Do not restore factory default settings
		C:01	Restore factory default settings
P:04	Number of cooking zone power levels	C:00	9 power levels + Booster
		C:01	17 power levels + Booster ⁴
P:06	Audible tone when a sensor control is touched	C:00	Off ⁵
		C:01	Quiet
		C:02	Medium
		C:03	Loud
P:07	Timer buzzer	C:00	Off
		C:01	Quiet
		C:02	Medium
		C:03	Loud
P:08	System lock	C:00	System lock can only be activated manually
		C:01	System lock activated automatically
P:09	Maximum operating time	C:00	Safety setting 0
		C:01	Safety setting 1
		C:02	Safety setting 2

Programming

Programme ¹		Code ²	Settings
P:10	WiFi registration	C:00	Not active/deactivated
		C:01	Active but not configured
		C:02	Active and configured (cannot be selected; displays whether connection was successful)
		C:03	Connection possible via WPS push button
		C:04	WiFi reset to default (C:00)
		C:05	Direct WiFi connection of hob and cooker hood without Miele app (Con@ctivity 3.0)
P:12	Sensor controls reaction speed	C:00	Slow
		C:01	Normal
		C:02	Fast
P:15	Permanent pan recognition	C:00	Permanent pan recognition off
		C:01	Permanent pan recognition on
P:16	Maximum cookware temperature for manual frying and cooking	C:00	160 °C
		C:01	170 °C
		C:02	180 °C
		C:03	190 °C
		C:04	200 °C
		C:05	210 °C
		C:06	220 °C
		C:07	230 °C
		C:08	240 °C
		C:09	250 °C
P:18	Empty cookware protection with manual cooking and frying	C:00	Off
		C:01	On

Programming

Programme ¹		Code ²	Settings
P:19	Frying level temperature ①	C:00	140 °C
		C:01	145 °C
		C:02	150 °C
		C:03	155 °C
		C:04	160 °C
		C:05	165 °C
		C:06	170 °C
		C:07	175 °C
		C:08	180 °C
P:20	Frying level temperature ②	C:00	180 °C
		C:01	185 °C
		C:02	190 °C
		C:03	195 °C
		C:04	200 °C
		C:05	205 °C
		C:06	210 °C
		C:07	215 °C
		C:08	220 °C
P:21	Frying level temperature ③	C:00	200 °C
		C:01	205 °C
		C:02	210 °C
		C:03	215 °C
		C:04	220 °C
		C:05	225 °C
		C:06	230 °C
		C:07	235 °C
		C:08	240 °C

Programming

Programme ¹		Code ²	Settings
P:25	Keeping warm Plus temperature	C:00	50 °C
		C:01	55 °C
		C:02	60 °C
		C:03	65 °C
		C:04	70 °C
		C:05	75 °C
		C:06	80 °C
		C:07	85 °C
		C:08	90 °C

¹ Unlisted programmes are not assigned.

² The factory-set code is shown in bold.

³ After the hob has been switched on *dE* appears in the timer display for a few seconds.

⁴ In the text and charts, the extended power levels are shown with a dot after the number for better understanding.

⁵ The audible tone for the On/Off sensor control cannot be switched off.



Risk of burning due to hot cooking zones.

The cooking zones will be hot after use.

Switch the hob off.

Allow the cooking zones to cool down before cleaning the hob.



Risk of damage due to moisture ingress.

The steam from a steam cleaning appliance could reach live electrical components and cause a short circuit.

Do not use a steam cleaner to clean the hob.

All surfaces could be discoloured or damaged if unsuitable cleaning agents are used. All surfaces are susceptible to scratching.

Remove all cleaning agent residues immediately.

Never use abrasive sponges or cleaning agents.

Allow the hob to cool down before cleaning.

- Clean the hob after every use.
- Dry the hob thoroughly after cleaning with water to avoid limescale residue.

Unsuitable cleaning agents

To avoid damaging the surfaces of the appliance, do not use:

- washing-up liquid
- cleaning agents containing soda, alkalines, ammonia, acids or chlorides
- cleaning agents containing descaling agents
- stain and rust removers
- abrasive cleaning agents, e.g. powder cleaners and cream cleaners
- solvent-based cleaning agents
- dishwasher cleaner
- oven sprays
- glass cleaning agents
- hard, abrasive brushes or sponges (e.g. pot scourers) or sponges which have been previously used and still contain abrasive cleaning agents
- melamine eraser blocks

Cleaning and care

Cleaning the ceramic surface

 Risk of damage by pointed objects.

The seal between the hob and the worktop could suffer damage.

The seal between the ceramic surface and the frame could suffer damage.

Do not use pointed objects for cleaning.

Not all soiling and residues can be removed using a solution of washing-up liquid. An invisible film can develop that can lead to discolouration of the glass ceramic surface. This discolouration cannot be removed.

Clean the ceramic surface regularly with a proprietary ceramic glass cleaning agent.

- Remove any coarse soiling with a damp cloth and more stubborn soiling with a shielded scraper blade suitable for use on glass.
- Then clean the ceramic glass surface with the Miele ceramic and stainless steel hob cleaner (see “optional accessories”) or with a proprietary ceramic glass cleaner applied with kitchen paper or a clean cloth. Do not apply the cleaner while the hob is still hot, as this can result in marking. Please follow the cleaning agent manufacturer's instructions.
- Finally wipe the glass ceramic surface with a damp cloth and polish with a soft, dry cloth.

Residues can burn onto the hob the next time it is used and cause damage to the glass ceramic surface. Ensure that all cleaning agent residues are removed.

- **Spots** caused by limescale, water and aluminium residues (spots with a metallic appearance) can be removed using Miele's ceramic and stainless steel hob cleaner.

 Risk of burning due to hot cooking zones.

The cooking zones are hot during use.

Wear oven gloves when removing residues of sugar, plastic or aluminium foil from a hot ceramic surface with a shielded scraper blade.

- Should any **sugar, plastic or aluminium foil** spill or fall onto the hot ceramic surface while it is in use, switch off the cooking zone.
- Then carefully scrape off these residues **immediately** whilst they are still hot, using a scraper blade suitable for use on glass.
- Afterwards, clean the ceramic surface in its cooled state, as described above.

Many malfunctions and faults that can occur in daily operation can be easily remedied. Time and money will be saved because a service call will not be needed.

The following guide may help you to find the reason for a malfunction or a fault, and to correct it.

Messages in the display

Issue	Cause and remedy
<p>Err is flashing alternately with 30 in the timer display and the buzzer is sounding.</p>	<p>The hob is incorrectly connected.</p> <ul style="list-style-type: none"> ■ Disconnect the hob from the mains electricity supply. ■ Contact your Miele dealer. The hob must be connected to the mains according to the wiring diagram.
<p>After the hob has been switched on, or after touching a sensor, LDC appears in the timer display for a few seconds.</p>	<p>The system lock or safety lock is activated.</p> <ul style="list-style-type: none"> ■ Deactivate the system lock or safety lock (see “System lock / Safety lock”).
<p>After the hob has been switched on, dE appears briefly in the timer display. The cooking zones do not heat up.</p>	<p>The hob is in demonstration mode.</p> <ul style="list-style-type: none"> ■ Touch the 0 sensor control on any of the numerical displays. ■ Then touch the 0 and 2 sensor controls at the same time until dE flashes alternately with DFF in the timer display.
<p>The hob has switched off automatically. When the element is switched back on, L appears above the On/Off sensor control ①.</p>	<p>One or more of the sensor controls are covered, e.g. by finger contact, food boiling over or an object.</p> <ul style="list-style-type: none"> ■ Clean off any dirt and/or remove the object (see “Safety features” – “Safety switch-off”).
<p>Err will flash alternately with 044 in the timer display.</p>	<p>The overheating protection mechanism has been activated.</p> <ul style="list-style-type: none"> ■ See “Safety features – Overheating protection”.

Problem solving guide

Issue	Cause and remedy
Err will flash alternately with <i>047, 048</i> or <i>049</i> in the timer display.	The fan is blocked or defective. <ul style="list-style-type: none">■ Make sure it has not been blocked by an object.■ Remove the obstruction.■ If this fault message continues to appear in the display, contact your Miele dealer.
In the timer display, E-digit, e.g. E-0, flashes alternately with <i>120, 121, 122, 123, 124, 125, 126, or 127.</i>	The fan is blocked or defective. <ul style="list-style-type: none">■ Make sure it has not been blocked by an object.■ Remove the obstruction.■ If this fault message continues to appear in the display, contact your Miele dealer.
A message not listed in this table is appearing in the timer display.	There is an electronic module fault. <ul style="list-style-type: none">■ Disconnect the power supply to the hob for approx. 1 minute.■ If the problem persists after power has been restored, please contact your Miele dealer.

Unexpected behaviour

Issue	Cause and remedy
The power level selected is flashing.	There is no pan on the cooking zone, or the pan is unsuitable. ■ Use suitable pans (see “Induction - Pans”).
Power level 9 is automatically reduced if you also set power level 9 for the connected cooking zone.	Operating both zones at power level 9 exceeds the permitted maximum power for the two zones. ■ Use a different cooking zone.
A cooking zone switches off automatically.	It has been operated for too long. ■ You can use the cooking zone again by switching it back on (see “Safety switch-off”).
The cooking zone is not working in the usual way on the power setting selected.	The overheating protection mechanism has been activated. ■ See “Safety features”.
A cooking zone or the whole hob switches off automatically.	The overheating protection mechanism has been activated. ■ See “Safety features”.
The Booster has deactivated early automatically.	The overheating protection mechanism has been activated. ■ See “Safety features”.

Problem solving guide

Unsatisfactory results

Issue	Cause and remedy
The food in the pan does not heat up when the Auto heat-up function is switched on.	A large amount of food is being heated up. ■ Start cooking at the highest power level and then turn down to a lower one manually later on.
	The pan is not conducting heat properly. ■ Use a different pot or pan which conducts heat properly.

General problems or technical faults

Issue	Cause and remedy
The hob or cooking zones will not switch on.	There is no power to the hob. ■ Check if the mains fuse has tripped. Contact a qualified electrician or your Miele dealer (for the minimum fuse rating, see data plate).
	There may be a technical fault. ■ Disconnect the appliance from the electricity supply for approx. 1 minute by – tripping the relevant mains fuse or screwing the fuse out completely, or – switching off at the residual current device. ■ If, after resetting the trip switch in the mains fuse box or the residual current device, the appliance will still not turn on, contact your Miele dealer.
A smell and vapours are given off when the new appliance is being used.	The metal components have a protective coating. When the appliance is used for the first time, this causes a smell and possibly also vapour. The material from which the induction coils are made also gives off a smell in the first few hours of operation. With each subsequent use, the odour is reduced until it disappears completely. The smell and any vapours given off do not indicate a faulty connection or appliance and they are not hazardous to health.
An operating noise can be heard after the appliance has been switched off.	The cooling fan runs until the hob has cooled down and then switches off automatically.

Miele offer a comprehensive range of useful accessories as well as cleaning and conditioning products for your Miele appliances.

These can be ordered from your Miele dealer (see end of this booklet for contact details).

Pans

Miele offer a wide range of cookware. These have all been optimised for Miele appliances in terms of functionality and dimensions. Please contact your Miele dealer for more details on individual products.

Cleaning and care products

Ceramic and stainless steel hob cleaner 250 ml



Removes heavy soiling, limescale deposits and aluminium residues

Microfibre cloth

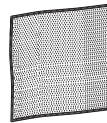

Removes finger marks and light soiling

After sales service

Contact in case of malfunction

In the event of any faults which you cannot remedy yourself, please contact your Miele dealer.

Contact details for your Miele dealer are given at the end of this document.

Please note that telephone calls may be monitored and recorded for training purposes and that a call-out charge will be applied to service visits where the problem could have been resolved as described in this booklet.

Please quote the model and serial number of your appliance when contacting your Miele dealer. This information can be found on the data plate.

Data plate

Stick the extra data plate supplied with the appliance here. Make sure that the model number matches the one specified on the back cover of this document.





Guarantee

For information on the appliance guarantee specific to your country please contact your Miele dealer. See end of this booklet for contact details.

Safety instructions for installation

 Risk of damage from incorrect connection.
Incorrect installation can cause damage to the hob.
The hob must only be installed by a qualified person.

 Risk of electric shock from mains voltage.
Incorrect connection to the mains supply may result in an electric shock.
The hob must be connected to the electrical supply by a qualified electrician only.

 Damage from falling objects.
Take care not to damage the hob when fitting wall units or a cooker hood above it.
Fit the wall units and the cooker hood before the hob.

- ▶ The veneer or laminate coatings of worktops (or adjacent kitchen units) must be treated with 100 °C heat-resistant adhesive which will not dissolve or distort. Any backmoulds must be of heat-resistant material.
- ▶ The hob must not be installed over a fridge, fridge-freezer, freezer, dishwasher, washing machine, washer-dryer or tumble dryer.
- ▶ This hob must not be installed above ovens or cookers unless these have a built-in cooling down fan.
- ▶ After installation, ensure that nothing can come into contact with the connection cable and that it is without hindrance.
- ▶ The electrical cable may not come into contact with any moving kitchen component (e.g. a drawer) or be subject to mechanical obstruction which could damage it.
- ▶ Observe carefully the safety clearances listed on the following pages.

Installation

Safety distances

Safety distance above the hob

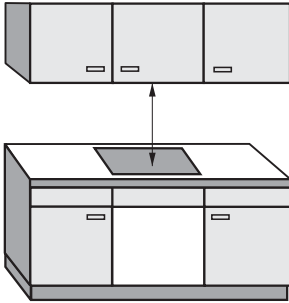

The safety distance specified by the manufacturer of the cooker hood must be maintained between the hob and the cooker hood above it.

If combustible objects are installed above the hob (e.g., cabinets, utensil rail, etc.), a minimum safety distance of 500 mm must be maintained.

When two or more appliances which have different safety distances are installed together below a cooker hood, you should observe the greatest specified safety distance.

Safety distances to the sides and back of the appliance

It is advisable to install the hob with plenty of space either side of it.

The minimum distance ① shown below must be maintained between the back of the hob and a tall unit or wall.

The minimum distance ②, ③ shown below must be maintained between a tall unit or a wall to the left or right of the hob with a minimum distance of 300 mm on the opposite side.

① Minimum distance between the **back** of the worktop cut-out and the rear edge of the worktop:
50 mm

② Minimum distance between the worktop cut-out and a wall or tall unit to the **right** of it:
50 mm.

③ Minimum distance between the worktop cut-out and a wall or tall unit to the **left** of it:
50 mm.

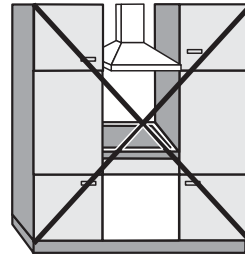

Not allowed

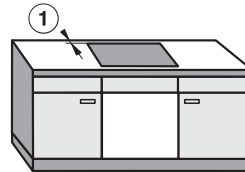
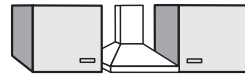

Highly recommended

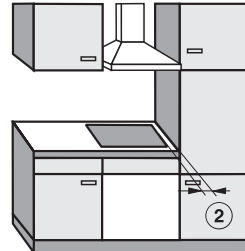

Not recommended

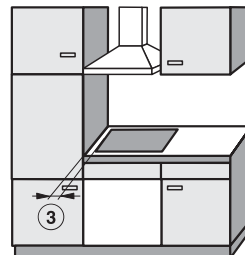

Not recommended

Installation

Minimum safety distance underneath the hob

To ensure sufficient ventilation to the hob, a minimum safety distance must be left between the underside of the hob and any oven, intermediate shelf or drawer.

The minimum safety distance between the underside of the hob and

- Upper edge of oven: 15 mm
- Upper edge of intermediate shelf: 15 mm
- Upper edge of drawer: 5 mm
- Base of drawer: 75 mm

Intermediate shelf

It is not necessary to fit an intermediate shelf underneath the hob, but one may be fitted if you wish.

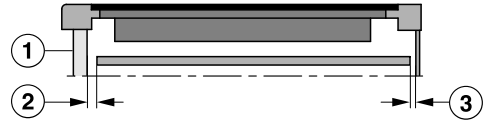

Side view

- ① Front
- ② Gap, front
- ③ Gap, back

A gap ② of 20 mm is recommended at the front between the cabinet and intermediate shelf for better **ventilation** of the hob.

Leave a gap ③ of 10 mm at the back between the cabinet and the intermediate shelf to **accommodate the power cable**.

Safety distance when installing the appliance near a wall with additional niche cladding

A minimum safety distance must be maintained between the worktop cut-out and any niche cladding to protect it from heat damage.

If the niche cladding is made from a combustible material (e.g. wood) a minimum safety distance ⑤ of 50 mm must be maintained between the cut-out and the cladding.

If the niche cladding is made from a non-combustible material (e.g. metal, natural stone, ceramic tiles) the minimum safety distance ⑤ between the cut-out and the cladding will be 50 mm less the thickness of the cladding.

Example: 15 mm niche cladding

50 mm - 15 mm = minimum safety distance of 35 mm

Flush-fitted hobs

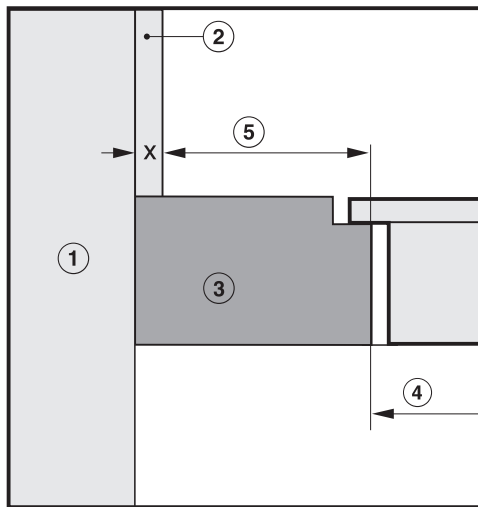

Hob with frame or bevelled edge

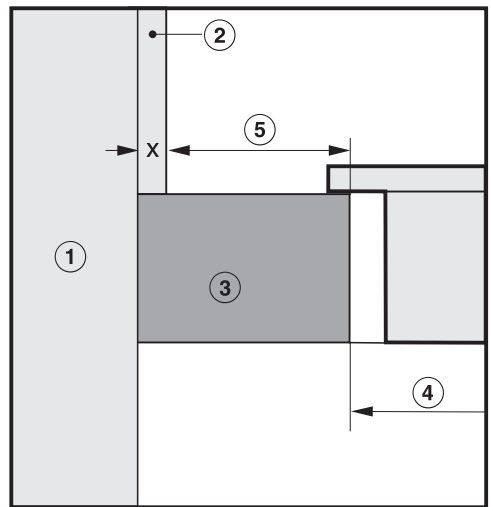

- ① Masonry
- ② Niche cladding dimension x = thickness of the niche cladding material
- ③ Worktop
- ④ Worktop cut-out
- ⑤ Minimum distance to
 - combustible** materials 50 mm
 - non-combustible** materials 50 mm - dimension x

Installation

Installation notes

Surface-mounted installation

Seal between the hob and the worktop

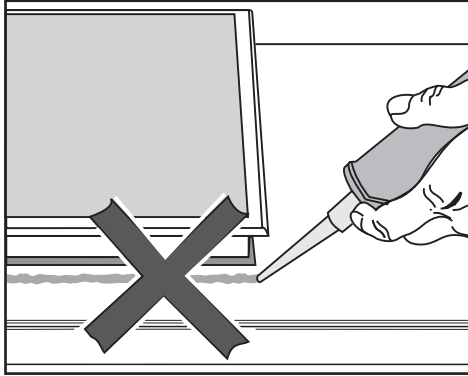

 Damage caused by incorrect installation.

Using sealant under the hob could result in damage to the hob and the worktop if the hob ever needs to be removed for servicing.

Do not use sealant between the hob and the worktop.

The sealing strip under the edge of the hob provides a sufficient seal for the worktop.

Tiled worktops

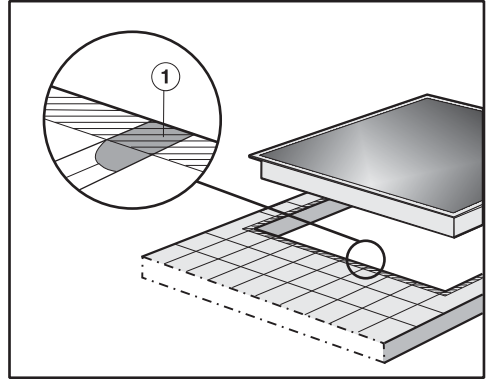

Grout lines ① and the hatched area underneath the hob frame must be smooth and even. If they are not the hob will not sit flush with the worktop and the sealing strip underneath the hob will not provide a good seal between the hob and the worktop.

Flush-fit installation

A flush-fit hob is suitable only for installation in natural stone (granite, marble), solid wood and tiled worktops. Certain models are also suitable for building into glass worktops – these are marked with an appropriate note in “Installation – Installation dimensions – flush-fit”. When using a worktop made from any other material, please check first with the worktop manufacturer that it is suitable for installing a flush-fit hob.

The internal width of the base unit underneath the appliance must be at least as wide as the inner worktop cut-out (see “Installation – Installation dimensions – flush fit”), so that the hob is easily accessible from underneath after installation and the casing can be removed for maintenance. If the underside of the hob is not freely accessible after installation, any sealant used must be removed to enable the hob to be lifted out of the cut-out should this be necessary.

Natural stone worktops

The hob is set directly in the cut-out.

Solid wood worktops, tiled worktops, glass worktops

The hob is secured inside the cut-out with wooden battens. The battens must be provided on site, and are not supplied with the appliance.

Sealing strip

Dismantling the hob for service purposes may damage the sealing strip underneath the edge of the hob. Always replace the sealing strip before reinstalling the hob.

Installation

Installation dimensions – Surface-mounted

All dimensions are given in mm.

KM 7679 FR

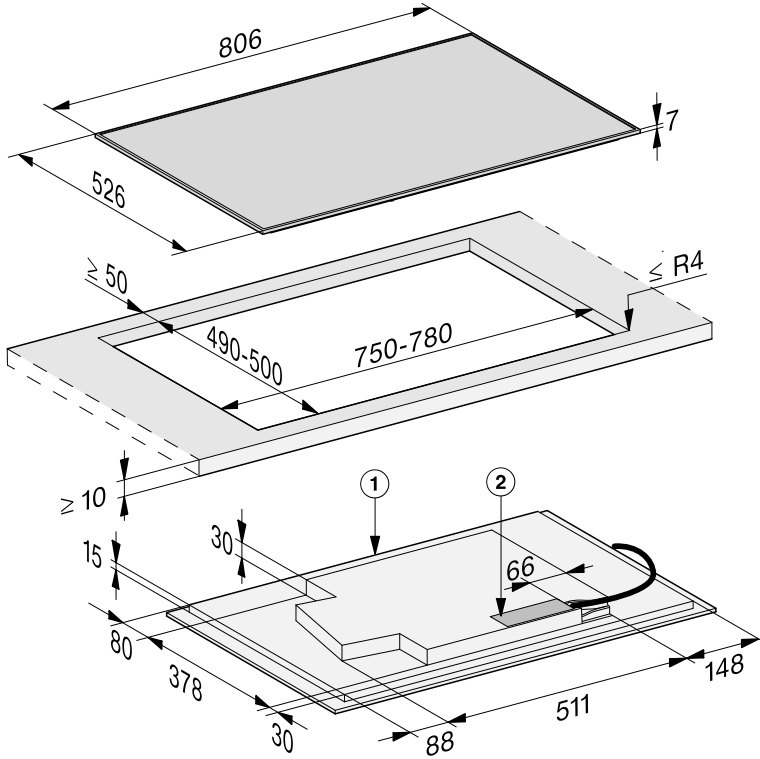

① Front

② Mains connection box

The mains connection cable (L = 1440 mm) is supplied loose

KM 7689 FL

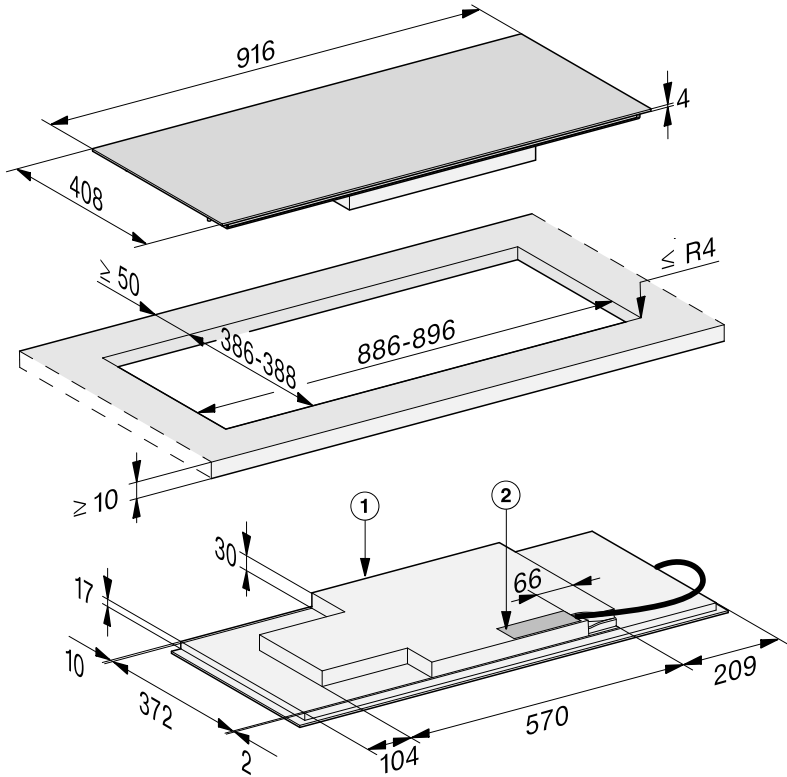

① Front

② Mains connection box

The mains connection cable (L = 1440 mm) is supplied loose

Installation

KM 7699 FR

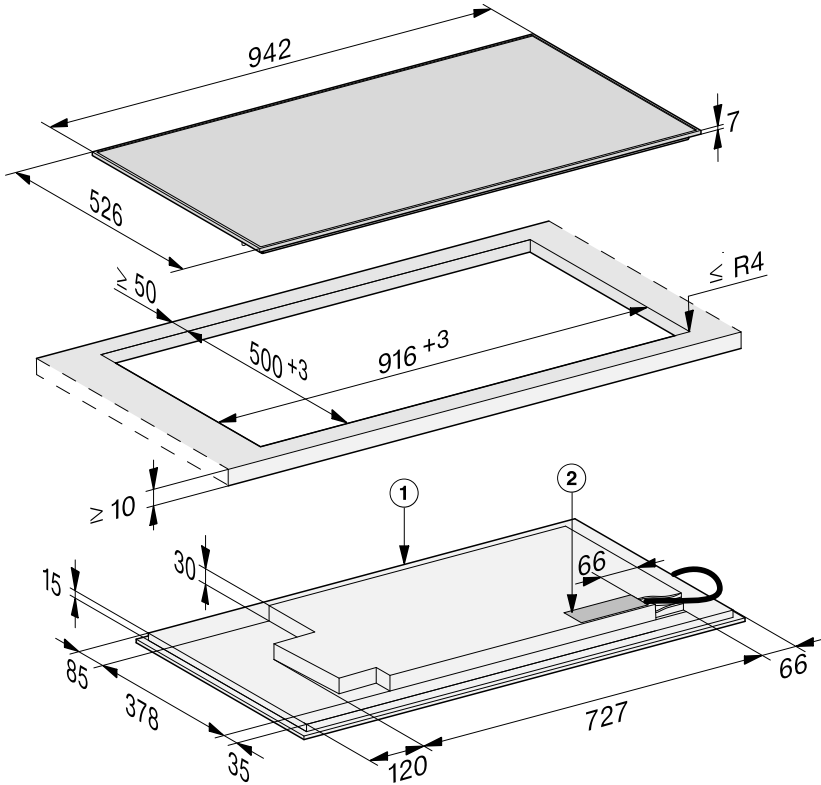

① Front

② Mains connection box

The mains connection cable (L = 1440 mm) is supplied loose

KM 7679 FL, KM 7879 FL

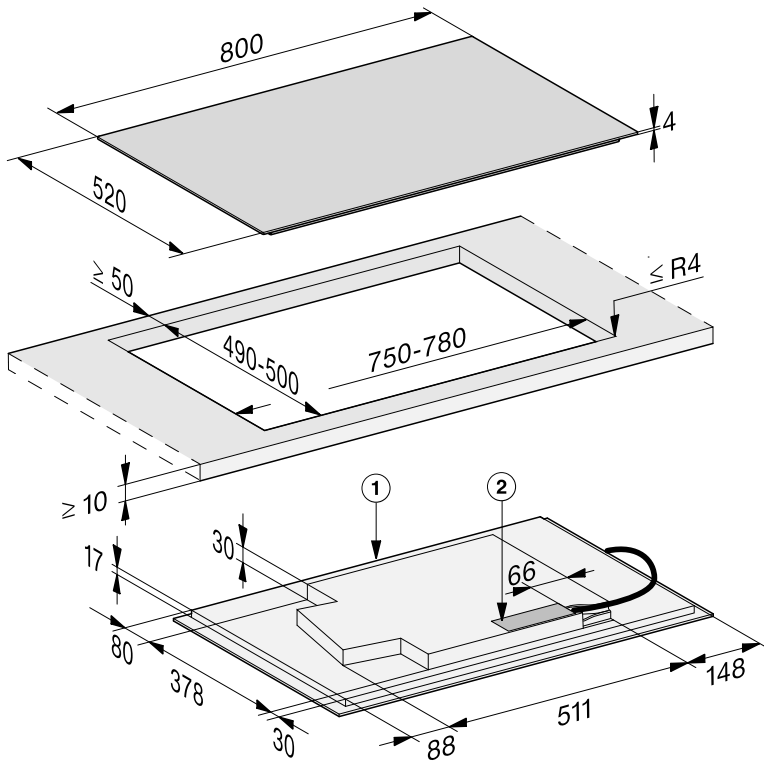

① Front

② Mains connection box

The mains connection cable (L = 1440 mm) is supplied loose

Installation

KM 7899 FL

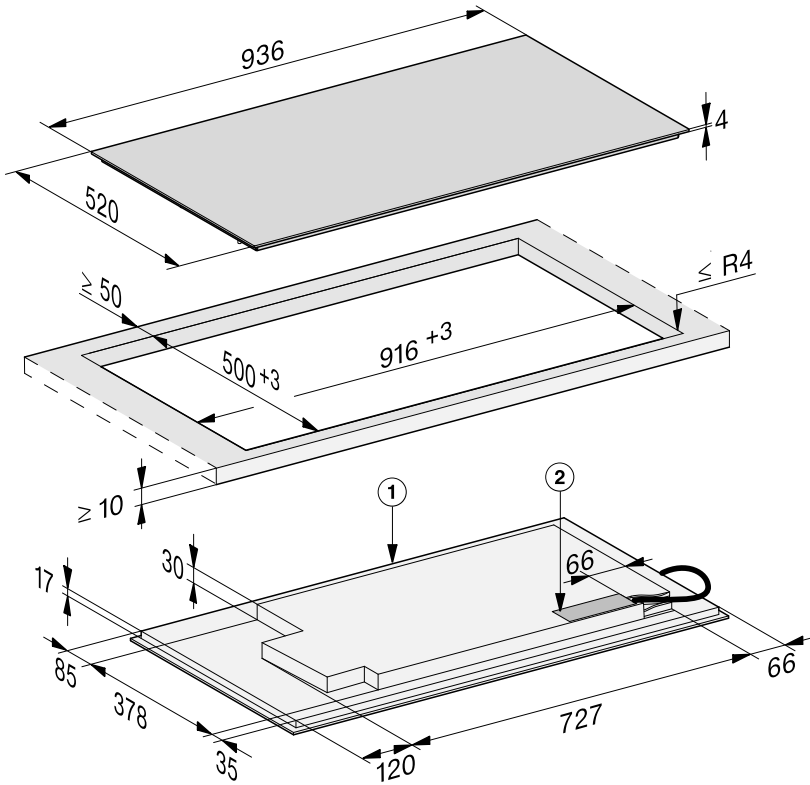

① Front

② Mains connection box

The mains connection cable (L = 1440 mm) is supplied loose

Surface-mounted installation

- Create the worktop cut-out.
Remember to maintain the minimum safety distances (see “Installation – Safety distances”).
- Seal any cut surfaces on **wooden worktops** with a special varnish, silicone sealant or resin to prevent the wood from swelling as a result of moisture ingress. The sealant must be heat-resistant.

Make sure that the sealant does not come into contact with the top of the worktop.

- Stick the supplied sealing strip under the edge of the hob. Do not apply the sealing strip under tension.



Risk of damage from incorrect connection.

The hob electronics may be damaged if a short-circuit occurs.
The power cable must be connected to the hob by a qualified electrician.

- Connect the power cable by following the instructions in the wiring diagram on the hob (see “Installation – Electrical connection”).
- Feed the power cable for the hob down through the worktop cut-out.
- Place the hob centrally in the cut-out. When doing this, make sure that the seal of the appliance sits flush with the worktop on all sides. This is important to ensure an effective seal all round.

If the seal does not sit flush with the worktop in the corners, the corner radius ($\leq R4$) can be carefully cut to fit using a jigsaw.

- Connect the hob to the electricity supply (see “Installation – Electrical connection”).
- Check that the hob works.

Installation

Installation dimensions – Flush-fit

All dimensions are given in mm.

KM 7629 FX

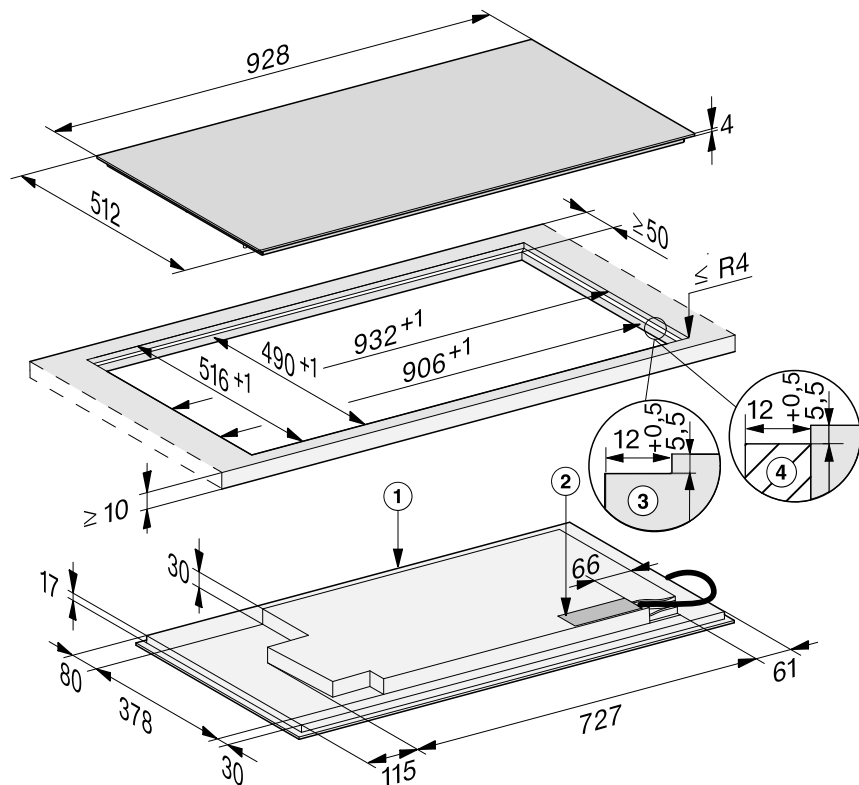

- ① Front
- ② Mains connection box
The mains connection cable (L = 1440 mm) is supplied loose
- ③ Stepped cut-out, natural stone worktop
- ④ Wooden batten 12 mm (not supplied)

KM 7689 FL

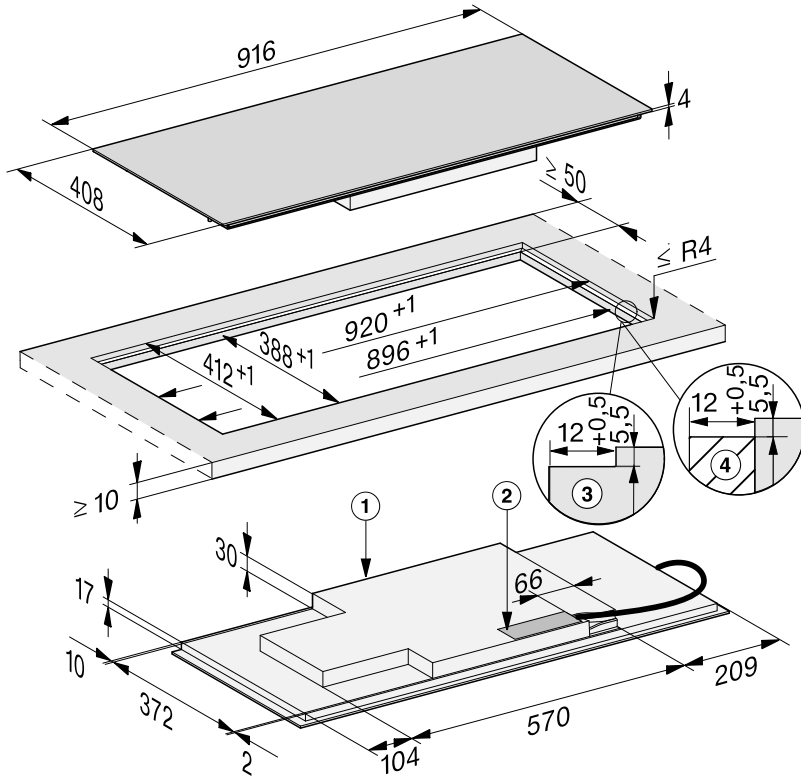

- ① Front
- ② Mains connection box
The mains connection cable (L = 1440 mm) is supplied loose
- ③ Stepped cut-out, natural stone worktop
- ④ Wooden batten 12 mm (not supplied)

Installation

KM 7679 FL, KM 7879 FL

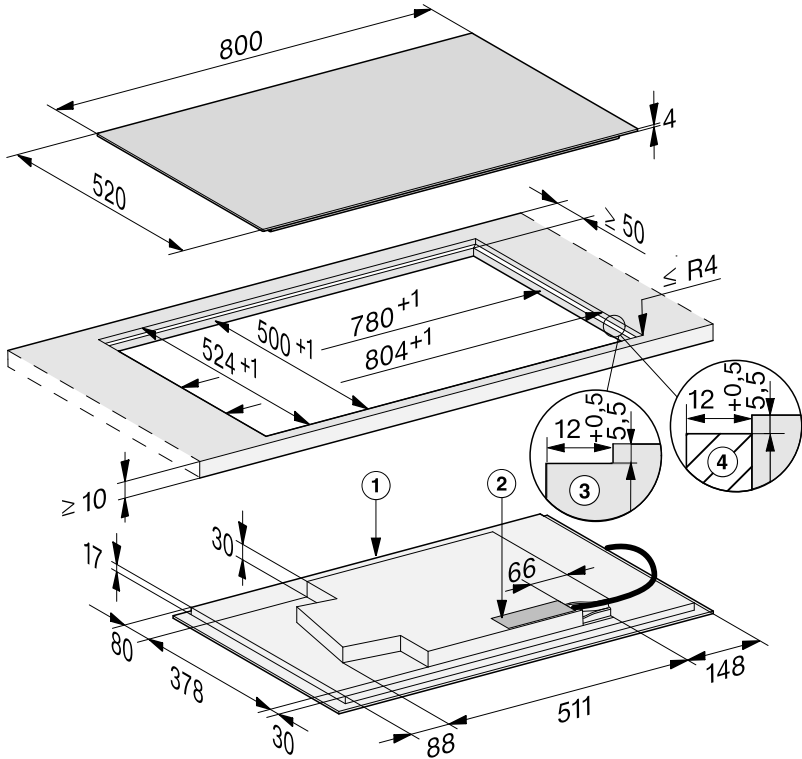

- ① Front
- ② Mains connection box
The mains connection cable (L = 1440 mm) is supplied loose
- ③ Stepped cut-out, natural stone worktop
- ④ Wooden batten 12 mm (not supplied)

KM 7899 FL

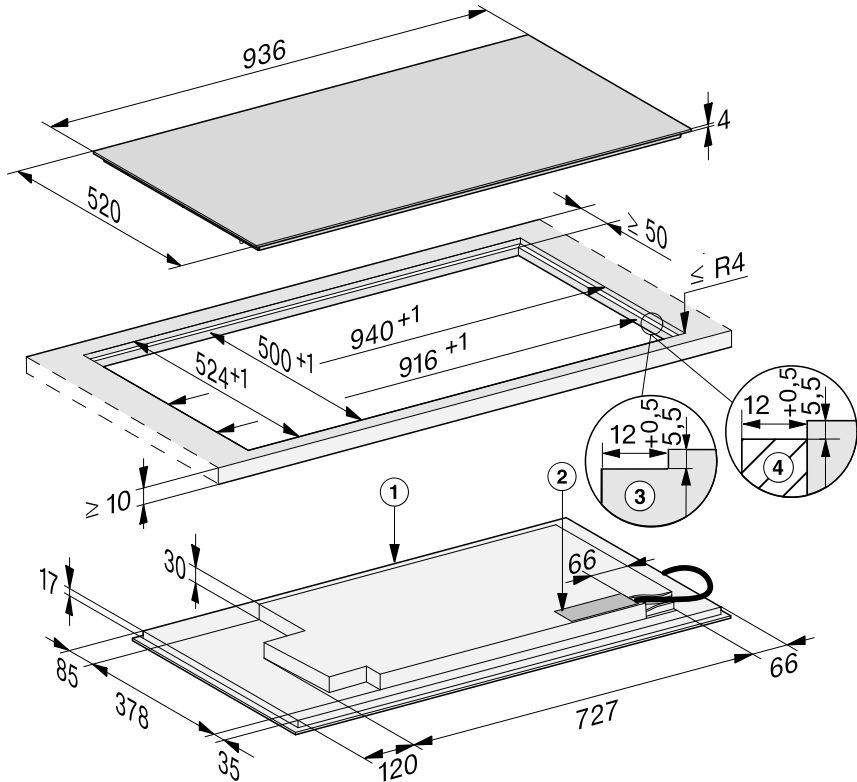

- ① Front
- ② Mains connection box
The mains connection cable (L = 1440 mm) is supplied loose
- ③ Stepped cut-out, natural stone worktop
- ④ Wooden batten 12 mm (not supplied)

Installation

Flush-fit installation

- Create the worktop cut-out.
Remember to maintain the minimum safety distances (see “Safety distances”).
- Solid wood, tiled and glass worktops:
Fix a wooden frame 5,5 mm below the top edge of the worktop.

 Risk of damage from incorrect connection.

The hob electronic module may be damaged if a short-circuit occurs.
The mains connection cable must be connected to the hob by a qualified electrician.

- Connect the electrical connection cable by following the instructions in the wiring diagram on the hob (see “Wiring diagram” in the “Electrical connection” chapter).
- Stick the supplied sealing strip under the edge of the hob. Do not apply the sealing strip under tension.
- Feed the mains connection cable for the hob down through the worktop cut-out.
- Centre the hob in the cut-out.

The gap between the ceramic glass surface and the worktop must be at least 2 mm wide. This is required so that the hob can be sealed.

- Connect the hob to the electricity supply (see “Electrical connection”).
- Check that the hob works.

- Seal the gap between the hob and worktop with a silicone sealant that is heat-resistant to at least 160 °C.

 Damage from unsuitable sealant.
Unsuitable sealant can damage natural stone.
For natural stone worktops and natural stone tiles, only use silicone sealant that is specially formulated for natural stone. Follow the manufacturer’s instructions.

Electrical connection

 Risk of damage from incorrect connection.

Unauthorised installation, maintenance and repairs can cause considerable danger for the user.

Miele cannot be held liable for damage or injury caused by unauthorised installation, maintenance or repair work, or by an inadequate or faulty on-site earthing system (e.g. electric shock).

This hob must be connected to the electrical supply by a qualified electrician.

The electrician must be familiar with and comply with the national regulations and any additional regulations of the local electricity provider.

After installation, ensure that all electrical components are shielded and cannot be accessed by users.

Total power rating

See data plate

Connection data

The connection data is quoted on the data plate. Please ensure these match the household mains supply.

Please see wiring diagrams for connection.

Disconnecting devices

It must be possible to disconnect the hob from the mains at all poles using disconnecting devices. A contact distance of at least 3 mm must be observed in the switched-off state. The disconnecting devices are overcurrent protection devices and residual current protection devices.

Installation

Disconnecting from the mains



Risk of electric shock.

There is a risk of electric shock if the appliance is connected to the mains supply during repair or service work. After disconnection, ensure the appliance cannot be switched back on by mistake.

To disconnect the appliance from the mains power supply, do one of the following depending on installation:

Safety fuses

- Completely remove fuses.

Automatic circuit breakers

- Press the (red) test button until the middle (black) button springs out.

Built-in circuit breakers

- Circuit breakers at least type B or C: Switch the lever from 1 (on) to 0 (off).

Residual current device (RCD)

- Switch the main switch from 1 (on) to 0 (off) or press the test button.

Mains connection cable

The hob must be connected to the electrical supply with a special connection cable, type H 05 VV-F (PVC insulated) with a suitable diameter.

Please see wiring diagram for connection.

See the data plate on the hob for the correct voltage and frequency.

Replacing the mains connection cable



Risk of electric shock.

Incorrect connection to the power supply may result in an electric shock.

The mains cable must only be replaced by a qualified electrician.

When replacing the mains cable only use cable type H 05 VV-F with a suitable cross section. A suitable connection cable is available from your Miele dealer.

Wiring diagram

Some connection methods are not permitted in all installation locations. Ensure compliance with national regulations and any additional regulations issued by the local electricity provider.

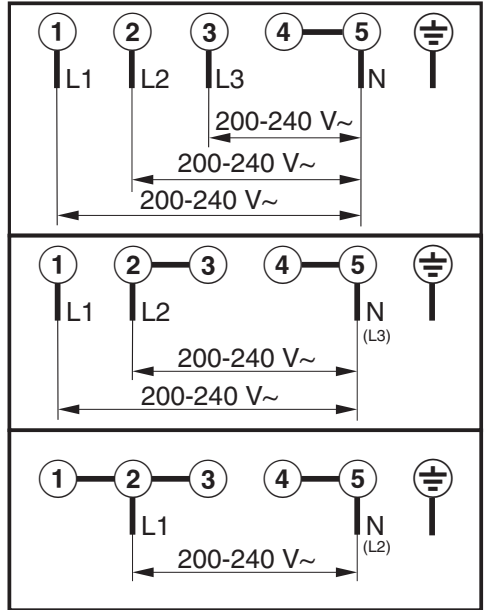

Miele Saudi Arabia

AWAD BADI NAHAS TRADING CO. LTD

Head Office:

Jeddah

P.O. Box 11529 Jeddah 21463

Tel. +966 12 2560888, Fax. +966 12 2560555

Hotline for customer care: 920003240

Website: www.awadnahas.com

Branches:

Jeddah

Madina Road

Tel. +966 12 6970060, Fax. +966 12 6970012

Jeddah

Sitteen Street

Tel. +966 12 6611675, Fax. +966 12 6606852

Jeddah

Miele Gallery

Al Thanyyan Group Building, Al-Madina Road,

Near, Al Rowdah District, Jeddah

Tel. +966 12 6989339 Ext. 100

Fax. +966 12 6989339 Ext. 200

Riyadh

Olaya Street

Tel. +966 11 2013501, Fax. +966 11 2013502

Taif

Hadiya Street

Tel. +966 12 7327001, Fax. +966 12 7369596

Khobar

Al Zahran Road

Tel. +966 13 8646150, Fax. +966 13 8646190

Miele United Arab Emirates

Miele Appliances Ltd.

Showroom 1

Eiffel 1 Building

Sheikh Zayed Road, Umm Al Sheif

P.O. Box 114782 - Dubai

United Arab Emirates

Tel. +971 4 3044 999

Fax. +971 4 3418 852

800-MIELE (64353)

E-Mail: info@miele.ae

Website: www.miele.ae

Webshop: shop.miele.ae

Manufacturer: Miele & Cie. KG, Carl-Miele-Straße 29, 33332 Gütersloh, Germany

KM 7629 FX, KM 7679 FR, KM 7679 FL, KM 7689 FL,
KM 7699 FR, KM 7879 FL, KM 7899 FL