

Operating and installation instructions SmartLine gas hob

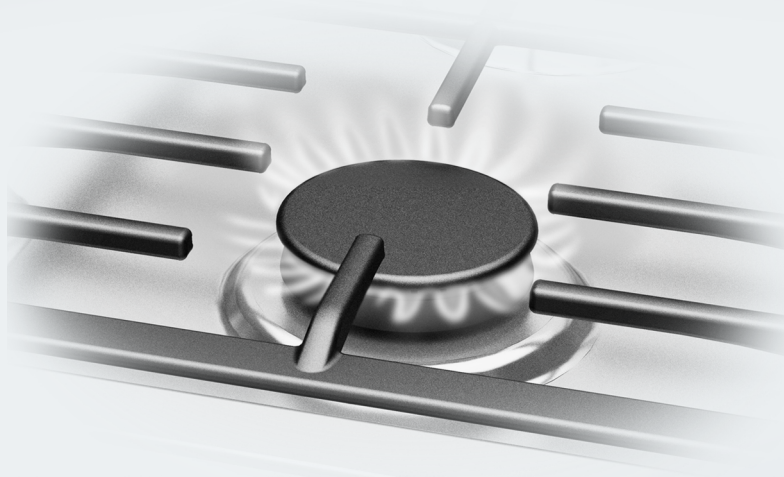

To avoid the risk of accidents or damage to the appliance it is **essential** to read these instructions before it is installed and used for the first time.

This appliance can be used in countries other than those specified on the appliance and in these operating and installation instructions. It is, however, set up for connection to the gas and electricity supplies in the countries specified. For trouble-free operation of the appliance, it is best to use it in the countries specified for use.

For use in other countries, please contact Miele in your country.

According to the Gas Safety Ordinance of Hong Kong, any gas installation works including the installation of appliances and connection tubing, must be undertaken by registered gas installers who are registered for that appropriate classes and be employed by registered gas contractors.

Safety precautions to take if you smell gas

- Turn off the gas emergency control valve immediately.
This is usually located near the gas meter.
- Eliminate all sources of ignition in a safe manner.
Do not smoke, light cigarette lighters or matches.
- Do not operate electrical lights or switches, i.e. do not switch them „On“ or „Off“.
- Open all doors and windows to ventilate the area.
- If the smell of gas persists, evacuate the building.

Contents

Warning and Safety instructions	6
Caring for the environment	17
Guide to the appliance	18
Hob.....	18
Control knobs.....	19
Burner.....	20
Before using for the first time	21
Cleaning the SmartLine element for the first time.....	21
Switching on the SmartLine element for the first time.....	21
Pans	22
Tips on saving energy	23
Operation	24
Switching on.....	24
Adjusting the flame.....	24
Switching off.....	24
Safety features	25
Thermocouple (flame failure monitor).....	25
Cleaning and care	26
Cleaning the ceramic surface.....	27
Cleaning the rotary controls	28
Cleaning the trivets.....	28
Cleaning the burners	29
Assembling the burners	30
Problem solving guide	31
Optional accessories	33
After sales service	34
Contact in the event of a fault	34
Data plate	34
Guarantee.....	34
Installation	35
Safety instructions for installation	35
Safety distances.....	37
Installation notes – surface-mounted	40
Worktop cutout – surface-mounted	42

Contents

Spacer bars – surface-mounted.....	44
Installation dimensions – Surface-mounted.....	45
Installation – surface-mounted.....	46
Installation notes – flush-fit.....	48
Worktop cutout – flush-fit.....	50
Spacer bars – flush-fit.....	52
Installation dimensions – Flush-fit.....	53
Installation – flush-fit.....	54
Gas connection.....	56
Burner ratings.....	58
Electrical connection.....	59
Technical Data.....	60

Warning and Safety instructions

This hob complies with all relevant local and national safety requirements. Inappropriate use can, however, lead to personal injury and material damage.

Read the operating and installation instructions carefully before using the hob. They contain important information on safety, installation, use and maintenance. This prevents both personal injury and damage to the hob.

Miele expressly and strongly advises that you read and follow the instructions in the chapter on installing the hob as well as the safety instructions and warnings.

Miele cannot be held liable for injury or damage caused by noncompliance with these instructions.

Keep these instructions in a safe place and pass them on to any future owner.

Correct application

- ▶ This hob is intended for domestic use and use in other similar environments.
- ▶ This hob is not intended for outdoor use.
- ▶ It is intended for domestic use only to cook food and keep it warm. Any other use is not supported by the manufacturer and could be dangerous.
- ▶ This hob is not intended for use by people with reduced physical, sensory or mental capabilities or lack of experience and knowledge, unless they have been given supervision and instruction concerning its use by a person responsible for their safety. They may only use the hob unsupervised if they have been shown how to use it in a safe way. They must be able to recognise and understand the dangers of misuse.

Warning and Safety instructions

Safety with children

- ▶ Children must be kept away from the hob unless they are constantly supervised.
- ▶ Juveniles may use the hob if its operation has been clearly explained to them and they are able to use it safely. They must be able to understand and recognise the possible dangers caused by incorrect operation.
- ▶ Children must not be allowed to clean the hob unsupervised.
- ▶ Please supervise children in the vicinity of the hob and do not let them play with it.
- ▶ The hob gets hot when in use and remains hot for a while after being switched off. Keep children well away from the hob until it has cooled down and there is no danger of burning.
- ▶ Danger of burning. Do not store anything which might arouse a child's interest in storage areas above or behind the hob. Otherwise they could be tempted to climb onto the hob.
- ▶ Risk of burning and scalding. Place pots and pans on the cooking zone in such a way that children cannot pull them down and burn themselves.
- ▶ Danger of suffocation! Whilst playing, children may become entangled in packaging material (such as plastic wrapping) or pull it over their head with the risk of suffocation. Keep packaging material away from children.

Technical safety

- ▶ Unauthorised installation, maintenance and repairs can cause considerable danger for the user. Installation, maintenance and repairs must only be carried out by a Miele authorised registered gas installer.
- ▶ Damage to the hob can compromise your safety. Check the hob for visible signs of damage. Do not use the hob if it is damaged.
- ▶ Temporary or permanent operation on an autonomous power supply system or a power supply system that is not synchronised with the mains power supply (e.g. island networks, back-up systems) is possible. A prerequisite for operation is that the power supply system complies with the specifications of EN 50160 or an equivalent standard.

The function and operation of the protective measures provided in the domestic electrical installation and in this Miele product must also be maintained in isolated operation or in operation that is not synchronised with the mains power supply, or these measures must be replaced by equivalent measures in the installation. As described, for example, in the current version of BS OHSAS 18001–2 ISO 45001.

- ▶ The electrical safety of this hob can only be guaranteed when correctly earthed. It is essential that this standard safety requirement is met. If in any doubt please have the electrical installation tested by a registered electrical worker.
- ▶ To avoid the risk of damage to the hob, make sure that the connection data on the data plate (voltage and frequency) match the mains electricity supply before connecting it to the mains. Consult a registered electrical worker if in doubt.
- ▶ Do not connect the hob to the mains electrical supply by a multi-socket adapter or extension lead. These are a fire hazard and do not guarantee the required safety of the appliance.

Warning and Safety instructions

- ▶ For safety reasons, this hob may only be used after it has been built in.
- ▶ This hob must not be used in a non-stationary location (e.g. on a ship).
- ▶ Never open the casing of the hob.
Touching or tampering with electrical connections or components and mechanical parts is highly dangerous to the user and can cause operational faults.
- ▶ While the hob is under warranty, repairs should only be undertaken by a Miele authorised service technician. Otherwise the warranty is invalidated.
- ▶ Miele can only guarantee the safety of the appliance when genuine original Miele replacement parts are used. Faulty components must only be replaced by Miele spare parts.
- ▶ The hob is not intended for use with an external timer switch or a remote control system.
- ▶ The connection to the gas supply must be carried out by a registered gas installer.
If the plug has been removed from the connection cable or the connection cable is not supplied with a plug, the hob must be connected to the electricity supply by a registered electrical worker (see “Electrical connection” in the “Installation” chapter).
- ▶ If the mains connection cable is damaged, it must be replaced with a special mains connection cable by a registered electrical worker (see “Electrical connection” in the “Installation” chapter).

Warning and Safety instructions

▶ During installation, maintenance and repair work, the hob must be disconnected from the mains electricity supply. The gas supply must also be shut off. Depending on territory this is done in one of several different ways:

- the mains fuse has been removed, or
- the screw-out fuse is removed (if applicable), or
- switch off at the wall socket and withdraw the plug from the socket. Pull by the plug and not by the mains connection cable to disconnect from the mains electricity supply.
- the gas inlet valve is closed.

▶ Risk of electric shock. Do not use the hob if it is faulty, or if the ceramic surface is cracked, chipped or damaged in any way. Switch it off immediately, do not touch the appliance surface and disconnect the hob from the mains electricity supply and the gas supply. Contact Miele.

▶ If the hob is installed behind a cabinet door, do not close the door while the hob is in use. Heat and moisture can build up behind the closed door. This can result in damage to the hob, the housing unit and the floor. Leave the furniture door open until the hob has cooled down completely.

▶ In areas which may be subject to infestation by cockroaches or other vermin, pay particular attention to keeping the appliance and its surroundings clean at all times. Any damage caused by cockroaches or other vermin will not be covered by the warranty.

Warning and Safety instructions

Correct use

- ▶ The hob gets hot when in use and remains hot for some time after being switched off. Do not touch the hob if there is a possibility that it could still be hot.
- ▶ Due to the high temperatures radiated, objects left near the hob when it is in use could catch fire.
Do not use the hob to heat up the room.
- ▶ Oil and fat can overheat and catch fire. Do not leave the hob unattended when cooking with oil and fat. If it does ignite do not attempt to put the flames out with water.
Disconnect the hob from the mains and use a suitable fire blanket, saucepan lid, damp towel or similar to smother the flames.
- ▶ Do not leave the SmartLine element unattended whilst it is being used. It should be continually monitored whilst boiling and flash frying.
- ▶ Flames could set the grease filters of a cooker hood on fire. Do not flambé under a cooker hood.
- ▶ Spray canisters, aerosols and other inflammable substances can ignite when heated. Therefore do not store such items or substances in a drawer under the hob. Cutlery inserts must be heat-resistant.
- ▶ Do not heat an empty pan.
- ▶ Do not heat up food in closed containers e.g. tins or sealed jars on the hob, as pressure can build up in the container, causing it to explode.
- ▶ Do not cover the hob, e.g. with a hob cover, a cloth or protective foil. The material could catch fire, shatter or melt if the hob is switched on by mistake or if residual heat is still present.

Warning and Safety instructions

- ▶ If the appliance is switched on by mistake, or if there is residual heat present, there is the risk of any metal items placed on the hob heating up. Other materials can melt or catch fire. Do not use the appliance as a resting place for anything.
- ▶ You could burn yourself on the hot hob. Protect your hands with heat-resistant pot holders or gloves when handling hot pots and pans. Do not let them get wet or damp, as this causes heat to transfer through the material more quickly with the risk of scalding or burning yourself on steam. Be sure to keep all textiles away from the gas flames. Do not use oversized cloths, tea towels or other similar materials.
- ▶ When using an electrical appliance, e.g. a hand-held food blender, near the hob, ensure that the cable of the electrical appliance cannot come into contact with the hot hob. The insulation on the cable could become damaged.
- ▶ Even a light object can cause damage in certain circumstances. Do not drop anything on the ceramic surface.
- ▶ Plastic and aluminium foil containers melt at high temperatures. Do not use plastic or aluminium foil containers.
- ▶ When a control knob is pressed down, a spark is generated on the ignitor. Do not press down the control knob while you are cleaning or touching the hob or a burner in the vicinity of an ignitor.
- ▶ If a cooker hood is installed above the hob, ensure that the burners are always covered with a pan when in use. Otherwise flames could reach the cooker hood, parts of which could then be damaged or even set on fire.
- ▶ Only light the gas burners after all burner parts have been properly assembled.

Warning and Safety instructions

- ▶ Pans must be the correct size for the burner they are used on (see „Pans“). A pan which is too small will be unstable on the pan support. If the pan diameter is too large, flames can spread out to the sides and damage or burn the worktop, wall claddings or surrounding units and also parts of the hob. Miele cannot be held liable for this type of damage.
- ▶ Ensure that the flames from the burner do not spread out beyond the base and up the sides of the pan.
- ▶ Do not use pans with very thin bases on this hob, and never heat up empty pans as they could get damaged. This could also damage the appliance.
- ▶ The pan support supplied with the appliance must always be used. Never place a pan on the burner itself.
- ▶ Replace the pan supports carefully to avoid scratching the surface.
- ▶ Do not use or store flammable materials near this hob.
- ▶ Remove splashes of fat and other food debris from the surface of the hob as soon as possible. These are a fire hazard.
- ▶ Using the hob will cause a build-up of heat and moisture in the room in which it is installed. Ensure that the room has sufficient natural or mechanical means of ventilation, e.g. a cooker hood.
- ▶ If the hob is used for very long periods of time, additional ventilation of the room may be necessary, e.g. by opening windows or doors, or running the cooker hood on the highest setting.
- ▶ Do not use roasting dishes, pans or grilling stones that are large enough to cover more than one burner. The resulting build-up of heat could damage the hob.

Warning and Safety instructions

► If the hob has not been used for a longer period of time, it should be thoroughly cleaned before it is used again. It is also advisable to have it tested by registered gas installer for safety. This should be done at regular intervals.

Warning and Safety instructions

Cleaning and care

- ▶ Do not use a steam cleaning appliance to clean this hob. The steam could reach electrical components and cause a short circuit.
- ▶ Miele will guarantee to supply functional spare parts for a minimum of 10 years and up to 15 years following the discontinuation of your CombiSet.

Disposing of the packaging material

The packaging material is used for handling and protects the appliance from transport damage. The packaging material used is selected from materials which are environmentally friendly for disposal and can generally be recycled.

Recycling the packaging material reduces the use of raw materials. Use material-specific collection points for valuable materials and take advantage of return options. Your Miele dealer will take the packaging material away.

Disposing of your old appliance

Electrical and electronic appliances often contain valuable materials. They also contain specific materials, compounds and components, which were essential for their correct function and safety. These could be hazardous to human health and to the environment if disposed of with your domestic waste or if handled incorrectly. Please do not, therefore, dispose of your old appliance with your household waste.



Please dispose of it at your local community waste collection / recycling centre for electrical and electronic appliances, or contact your dealer or Miele for advice. You are also responsible (by law, depending on territory) for deleting any personal data that may be stored on the appliance being disposed of. Please ensure that your old appliance poses no risk to children while being stored prior to disposal.

Guide to the appliance

Hob

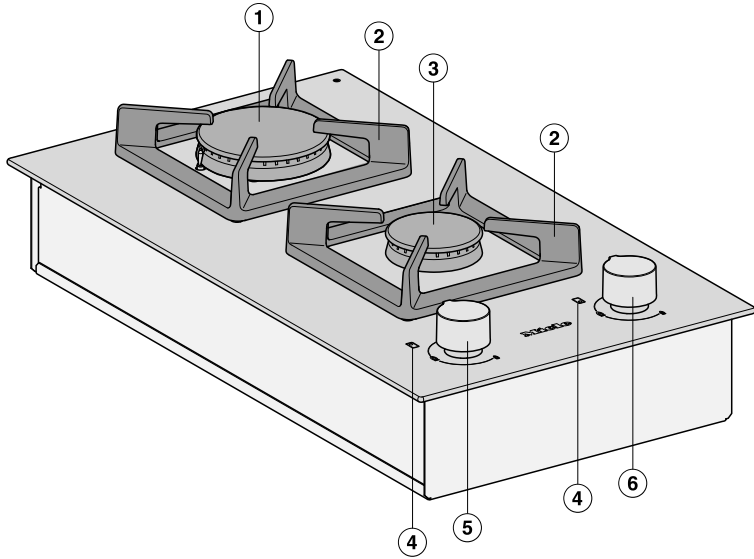

- ① Large burner
- ② Trivet
- ③ Medium burner
- ④ Symbols for allocation of operating controls
- ⑤ Rotary control for rear burner
- ⑥ Rotary control for front burner

Control knobs

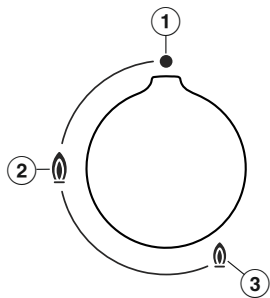

- ① • Burner off
The gas supply is turned off
- ② 🔥 Strong flame
The burner is on the highest setting
- ③ 🔥 Weak flame
The burner is on the lowest setting

Guide to the appliance

Burner

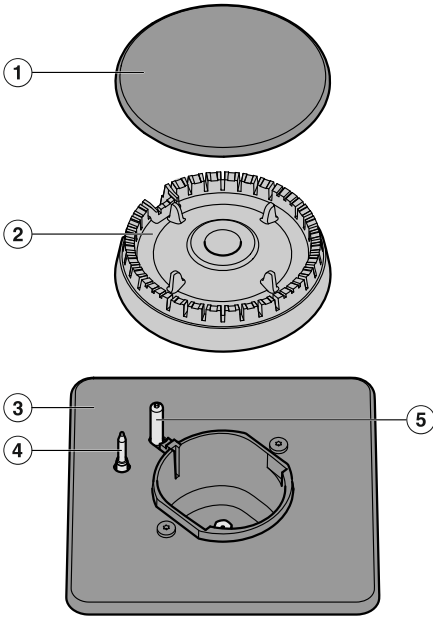

- ① Burner cap
- ② Burner head
- ③ Burner base
- ④ Thermocouple
- ⑤ Ignition electrode

- Please stick the extra data plate for the appliance supplied with this documentation in the space provided in the “After sales service” section of this booklet.
- Remove any protective wrapping and stickers.

Cleaning the SmartLine element for the first time

- Clean all removable parts of the burners with a solution of warm water and a small amount of washing-up liquid applied with a soft sponge. Dry all parts thoroughly after cleaning and then reassemble the burners (see “Cleaning and care”).
- Clean the ceramic surface with a damp cloth, and then wipe dry.

Switching on the SmartLine element for the first time

The metal components have a protective coating. Smells and possibly some vapours may occur when the SmartLine element is used for the first time.

The smell and any vapours given off do not indicate a faulty connection or appliance and they are not hazardous to health.

Pans

Minimum cookware base diameter [cm]	
Medium burner	12
Large burner	14

Maximum diameter at top of cookware [cm]	
Medium burner	24
Large burner	26

Maximum weight of cookware when filled [kg]	
Medium burner	10
Large burner	13

- Select the cookware to suit the size of the burner:
large diameter = large burner
small diameter = small burner
- Observe the dimensions given in the chart. Using pans that are too large can cause the flames to spread out and damage the surrounding worktop or other appliances. Using pans of the correct size improves efficiency. Pans that are smaller than the trivets and pans that do not stand safely (without wobbling) on the trivets are dangerous and should not be used.
- In contrast to pans for use on electric hobs, the bases of pans for use on gas hobs do not need to be flat to achieve good results.
- Remember when purchasing new pans that manufacturers usually refer to the diameter at the top of the pan in their documentation, and not to the base diameter.

- You can use any cookware that is heat-resistant.
- Cookware with a thick base is preferable as the heat is distributed evenly. With thin bases, there is the risk that food will overheat in places. Therefore it should be stirred more frequently.
- Always place the cookware on the trivet supplied. Do not place cookware directly on the burners.
- Place the cookware on the trivet in such a way that it cannot tip over. A little movement is quite normal and not a cause for concern.



- Do not use pots or pans with an edge-supported base.

Tips on saving energy

- Use a pan lid whenever possible to minimize heat loss.

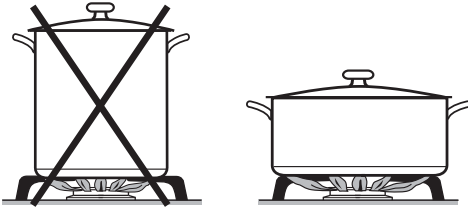

- Wide, shallow pans are preferable to tall, narrow ones. They will heat up faster.
- Cook with as little water as possible.
- Reduce the size of the flame once the water has come to the boil or the oil is hot enough to fry in.
- Use a pressure cooker to reduce cooking times.

Operation

Switching on

 Risk of fire with overheated food. Unattended food can overheat and catch alight.

Do not leave the hob unattended whilst it is being used.

- Press in the relevant rotary control and turn it anti-clockwise to the large flame symbol. The ignition electrode will “click” and ignite the gas.

When the rotary control is operated, a spark is automatically produced on all burners. This is normal and does not indicate a fault.

- When a flame is visible, keep the rotary control pressed down for 5–10 seconds, and then let it go.
- If the burner does not ignite, turn the rotary control to • burner off. Ventilate the room or wait for at least 1 minute before trying again. When making another ignition attempt, it may be necessary to hold the rotary control for longer.
- If the burner does not ignite the second time, turn the rotary control back to • burner off and see “Problem solving guide”.

Adjusting the flame

The burners can be regulated at any level between the strongest and weakest flame.

As the outer part of the flame is much hotter than the centre, the tips of the flames should stay beneath the pan base. Flame tips which extend beyond the sides of the pan merely warm up the air in the room and can also damage pan handles and increase the danger of injury.

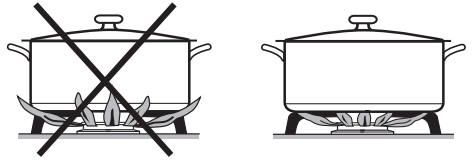

- Adjust the flame so that it does not spread out beyond the sides of the pan.

Switching off

- Turn the rotary control clockwise to • burner off.

The gas supply is cut off and the flame goes out.

Thermocouple (flame failure monitor)

This hob has a thermocouple. If the flame goes out, for example because food has boiled over or if there has been a sudden draught, the supply of gas to the burner will be cut off. This will prevent any gas escaping. To use the burner again, turn the control knob to “•”.

The thermocouple operates independently from the electricity supply. This means that it will still work if the hob is used during a power cut.

Cleaning and care

 Danger of burning due to hot surfaces.

The hob surface, pan supports and burners will be hot after use.

Allow the hob to cool down before cleaning it.

 Risk of damage due to moisture ingress.

The steam from a steam cleaning appliance could reach live electrical components and cause a short circuit.

Do not use a steam cleaner to clean the hob.

All surfaces could be discoloured or damaged if unsuitable cleaning agents are used. All surfaces are susceptible to scratching.

Remove all cleaning agent residues immediately.

Never use abrasive sponges or cleaning agents.

Food boiling over can cause discoloration of the burner components.

Remove any soiling and salt and sugar splashes immediately.

When a control knob is pressed down, a spark is generated on the ignitor. Do not press down the control knob while you are cleaning or touching the hob or a burner in the vicinity of an ignitor.

Allow the SmartLine element to cool down before cleaning.

- Clean the SmartLine element and accessories after each use.
- Dry the SmartLine element thoroughly after every cleaning to avoid limescale residue.

Unsuitable cleaning agents

To avoid damaging the surfaces of the appliance, do not use:

- cleaning agents containing soda, alkalines, ammonia, acids or chlorides
- cleaning agents containing descaling agents
- stain and rust removers
- abrasive cleaning agents, e.g. powder cleaners and cream cleaners
- solvent-based cleaning agents
- dishwasher cleaner
- oven sprays
- glass cleaning agents
- hard, abrasive brushes or sponges (e.g. pot scourers), or sponges which have been previously used and still contain abrasive cleaning agents
- melamine eraser blocks

Cleaning the ceramic surface

 Risk of damage by pointed objects.

The seal between the SmartLine element and the worktop could suffer damage.

Do not use pointed objects for cleaning.

Not all soiling and residues can be removed using a solution of washing-up liquid.

An invisible film can develop that can lead to discolouration of the glass ceramic surface. This discolouration cannot be removed.

Clean the ceramic surface regularly with a proprietary ceramic glass cleaning agent.

- Remove any coarse soiling with a damp cloth and more stubborn soiling with a shielded scraper blade suitable for use on glass.
- Then clean the ceramic glass surface with the Miele ceramic and stainless steel hob cleaner (see “optional accessories”) or with a proprietary ceramic glass cleaner applied with kitchen paper or a clean cloth. Do not apply the cleaner while the ceramic surface is still hot, as this can result in marking. Please follow the cleaning agent manufacturer's instructions.
- Finally wipe the glass ceramic surface with a damp cloth and polish with a soft, dry cloth.

Residues can burn onto the ceramic surface the next time it is used and cause damage to the glass ceramic surface. Ensure that all cleaning agent residues are removed.

- **Spots** caused by limescale, water and aluminium residues (spots with a metallic appearance) can be removed using Miele's ceramic and stainless steel hob cleaner.

 Danger of burning due to hot surfaces.

The surfaces get hot during cooking. Wear oven gloves when removing residues of sugar, plastic or aluminium foil from a hot ceramic surface with a shielded scraper blade.

- Should any **sugar, plastic or aluminium foil** spill or fall onto the hot ceramic surface while it is in use, switch off the cooking zone.
- Then carefully scrape off these residues **immediately** whilst they are still hot, using a scraper blade suitable for use on glass.
- Afterwards, clean the ceramic surface in its cooled state, as described above.

Cleaning and care

Cleaning the rotary controls

- Clean the rotary control(s) using a solution of warm water and a little washing-up liquid applied with a soft sponge. Soften any stubborn soiling beforehand.
- Dry the control(s) with a clean cloth.

Cleaning the trivets

- Remove the trivets.
- Clean the trivets in a dishwasher or with a solution of warm water and a little washing-up liquid applied with a soft sponge. Soften any stubborn soiling beforehand.
- Dry the trivets thoroughly with a clean cloth.

Cleaning the burners

Do not clean any parts of the burners in a dishwasher.

The surface of the burner cap will become duller with time. This is completely normal and does not indicate material deterioration.

- The burner should be dismantled and then cleaned by hand using a solution of warm water and a little washing-up liquid applied with a soft sponge.
- Clean any soiling from the flame openings.



Danger of explosion.

Blocked flame openings can cause a dangerous build-up of gas in the base of the hob which could ignite and cause an explosion. This can lead to damage to the appliance and injury.

Ensure the flame openings are kept clean at all times.

- Parts of the burner that cannot be removed should be wiped clean with a damp cloth only.
- The ignitor and thermocouple should be very carefully wiped clean using a well wrung-out cloth.

The ignitor must not get wet, otherwise it will not spark.

- Finally dry everything thoroughly with a clean cloth. Make sure that the flame openings are completely dry.

The surface of the burner cap will become duller with time. This is completely normal and does not indicate material deterioration.

Cleaning and care

Assembling the burners

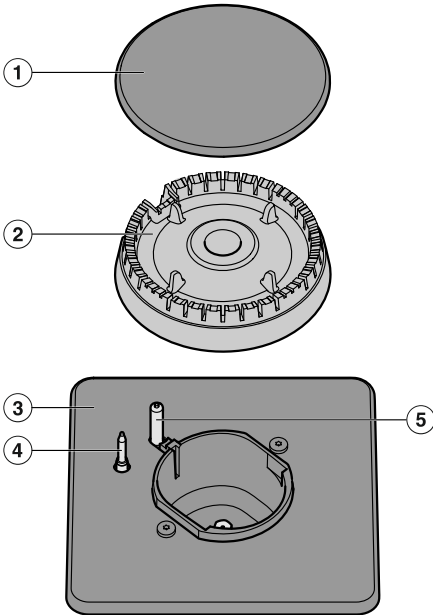

- Place the burner head ② onto the burner base ③ so that the thermocouple ④ and the ignition electrode ⑤ extend through their respective holes in the burner head. The burner head must click into place correctly.
- Place the burner cap ① flat over the burner head ②. When correctly positioned, the burner cap will not slide about.

Ensure that all parts of the burner are reassembled in the correct order.

Functional check

- Ignite all burners to check that they are burning correctly:
 - The flame must not go out on the lowest setting, or when the control is turned quickly from the highest to the lowest setting.
 - On the highest setting, the flame must have a distinctive and visible core.

Problem solving guide

Many malfunctions and faults that can occur in daily operation can be easily remedied. Time and money will be saved because a service call will not be needed.

The following guide may help you to find the reason for a malfunction or a fault, and to correct it.

Problem	Cause and remedy
<p>The burners do not ignite when the hob is being used for the first time or after it has been out of use for a longer period.</p>	<p>There could be an air lock in the gas pipe.</p> <ul style="list-style-type: none"> ■ You may need to make several attempts before the burner ignites successfully.
<p>The burner does not light after several attempts.</p>	<p>There is a technical fault.</p> <ul style="list-style-type: none"> ■ Turn all of the rotary controls clockwise to • burner off and interrupt the power supply to the hob for a few seconds. <p>The burner is not correctly assembled.</p> <ul style="list-style-type: none"> ■ Assemble the burner correctly. <p>The gas shut-off device has not been opened.</p> <ul style="list-style-type: none"> ■ Open the gas shut-off device. <p>The burner is wet and/or dirty.</p> <ul style="list-style-type: none"> ■ Clean and dry the burner. <p>The flame openings are blocked and/or wet.</p> <ul style="list-style-type: none"> ■ Clean and dry the flame openings.
<p>The gas flame goes out after ignition.</p>	<p>The flames do not touch the thermocouple and the burner does not get hot enough: The burner parts are not positioned correctly.</p> <ul style="list-style-type: none"> ■ Assemble the burner components correctly. <p>The thermocouple is dirty.</p> <ul style="list-style-type: none"> ■ Remove any soiling.
<p>The flame suddenly looks different.</p>	<p>The burner parts are not positioned correctly.</p> <ul style="list-style-type: none"> ■ Position the burner parts correctly. <p>The burner head or the holes in the burner cap are dirty.</p> <ul style="list-style-type: none"> ■ Remove any soiling.

Problem solving guide

Problem	Cause and remedy
The gas flame goes out during use.	The burner parts are not positioned correctly. ■ Position the burner parts correctly.
The ignitor on the burner does not spark.	The mains fuse has tripped. ■ You may need to contact a registered electrical worker or Miele.
	There is food residue stuck between the ignitor and the burner cap. There is food residue on the thermocouple. ■ Remove any soiling (See „Cleaning and care“).

Miele offer a comprehensive range of useful accessories as well as cleaning and conditioning products for your Miele appliances.

These products can be ordered through the Miele Webshop.

They can also be ordered from Miele (see end of this booklet for contact details) or from your Miele dealer.

Ceramic and stainless steel hob cleaner 250 ml

Removes heavy soiling, limescale deposits and aluminium residues.

Microfibre cloth

For removing finger marks and light soiling.

After sales service

Contact in the event of a fault

In the event of any faults which you cannot remedy yourself, please contact your Miele dealer or the Miele Customer Service Department.

You can book a Miele Customer Service Department call-out online at www.miele.com/service.

Contact information for the Miele Customer Service Department can be found at the end of this document.

Please quote the model identifier and serial number of your appliance (Fabr./SN/ Nr.) when contacting the Miele Customer Service Department. This information can be found on the data plate.

Please note that telephone calls may be monitored and recorded for training purposes and that a call-out charge will be applied to service visits where the problem could have been resolved as described in this booklet.

Data plate

Stick the extra data plate supplied with the appliance here. Make sure that the model number matches the one specified on the back cover of this document.



Guarantee

For information on the appliance guarantee specific to your country please contact Miele. See end of this booklet for contact details.

Safety instructions for installation



Damage risk from incorrect installation.

Incorrect installation can cause damage to the SmartLine element.

The SmartLine element must only be installed by a qualified person.



Damage from falling objects.

Take care not to damage the SmartLine element when fitting wall units or a cooker hood above it.

Fit the wall units and the cooker hood before the SmartLine element.

- ▶ The room in which the SmartLine element is installed must conform to all relevant local and national building regulations and safety regulations.
- ▶ The veneer or laminate coatings of worktops (or adjacent kitchen units) must be treated with 100 °C heat-resistant adhesive which will not dissolve or distort. Any backmoulds must be of heat-resistant material.
- ▶ A deep fat fryer must not be installed directly next to a gas hob or a wok burner as the gas flames could ignite the fat in the fryer. It is essential to maintain a distance of at least 288 mm between these two appliances.
- ▶ The SmartLine element must not be installed over a fridge, fridge-freezer, freezer, dishwasher, washing machine, washer-dryer or tumble dryer.
- ▶ When installing the SmartLine element, make sure that the gas pipe and mains connection cable cannot come into contact with hot appliance parts.
- ▶ The mains connection cable and any flexible gas connection pipes must be installed in such a way so that they do not come into contact with any moving kitchen parts (e.g. a drawer) after the SmartLine element has been installed, and that they cannot be subjected to any mechanical action which could cause damage.

Installation

- ▶ Observe carefully the safety clearances listed on the following pages.

Safety distances

Safety distance above the SmartLine element



The safety distance specified by the manufacturer of the cooker hood must be maintained between the SmartLine element and the cooker hood above it.

If combustible objects are installed above the SmartLine element (e.g. cabinets, utensil rail, etc.), a minimum safety distance of 760 mm must be maintained.

When two or more SmartLine elements which have different safety distances are installed together below a cooker hood, you should observe the greatest specified safety distance.

Safety Distance below the appliance

There should be at least 30 mm height or plenty of space reserved below the appliance for the installation of the flexible gas connection pipe and electrical cable. It also avoids any possible hindrance towards the movement of all moveable kitchen parts (e.g. drawer).

Installation

Safety distances to the sides and back of the appliance

The SmartLine element should preferably be installed with plenty of space on the right and left.

The minimum distance ① specified below must be observed between the rear of the SmartLine element and a tall unit or room wall.

The minimum distance ②, ③ specified below must be adhered to between one side of the SmartLine element (right or left) and a tall unit or room wall. A minimum distance of 300 mm must be observed on the opposite side.

① Minimum distance between the **back** of the worktop cut-out and the rear edge of the worktop: 50 mm

② Minimum distance on the **right** side between the worktop cut-out and the closest adjacent piece of furniture (e.g. tall unit) or a room wall: 100 mm.

③ Minimum distance on the **left** side between the worktop cut-out and the closest adjacent piece of furniture (e.g. tall unit) or a room wall: 100 mm.

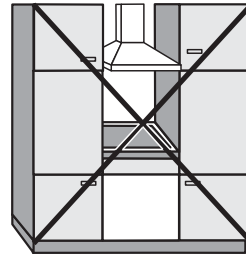

Not allowed

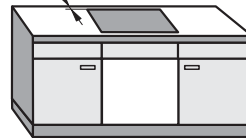
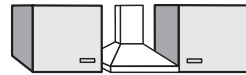

Highly recommended

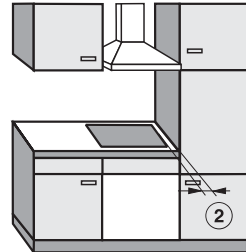

Not recommended

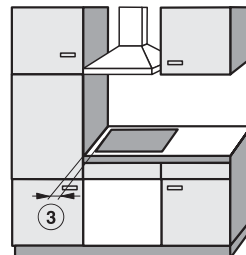

Not recommended

Safety distance when installing the appliance near a wall with additional niche cladding

If a niche cladding is installed, a minimum safety distance must be maintained between the worktop cut-out and the cladding, since high temperatures can damage these materials.

If the niche cladding is made from a combustible material (e.g. wood) a minimum safety distance ⑤ of 50 mm must be maintained between the worktop cut-out and the cladding.

If the niche cladding is made from a non-combustible material (e.g. metal, natural stone, ceramic tiles) the minimum safety distance ⑤ between the worktop cut-out and the cladding will be 50 mm less the thickness of the cladding.

Example: 15 mm niche cladding

50 mm - 15 mm = minimum safety distance of 35 mm

Flush-fit installation

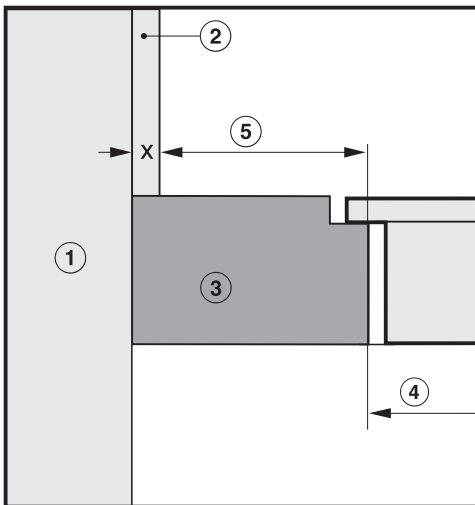

Onset installation

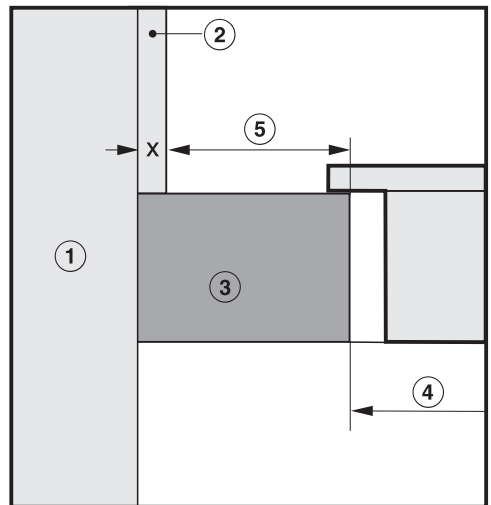

- ① Masonry
- ② Niche cladding dimension x = thickness of the niche cladding material
- ③ Worktop
- ④ Worktop cut-out
- ⑤ Minimum distance to
combustible materials 50 mm
non-combustible materials 50 mm - dimension x

Installation

Installation notes – surface-mounted

Sealing between the SmartLine Element and the worktop

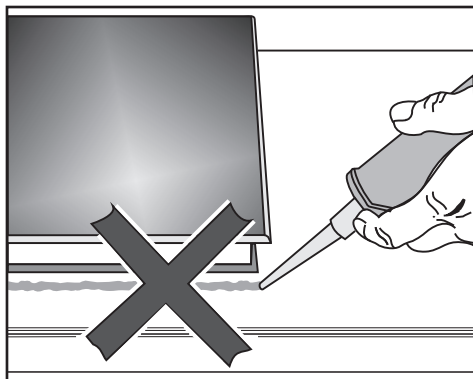

The SmartLine element and worktop may be damaged if the element needs to be removed after it has been sealed with a sealant.

Do not use any sealant between the SmartLine element and the worktop. The seal under the edge of the top part of the appliance provides a sufficient seal for the worktop.

Sealing strip

Dismantling the SmartLine element for service purposes may damage the sealing strip underneath the edge of the SmartLine element.

Always replace the sealing strip before reinstalling the SmartLine element.

Tiled worktop

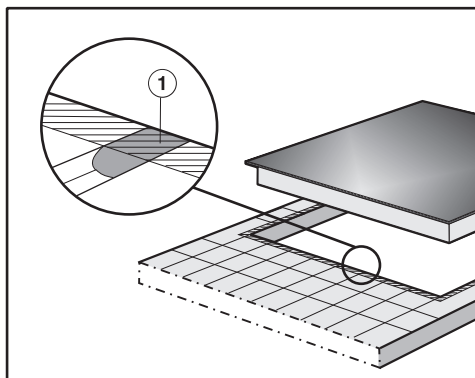

Grout lines ① and the hatched area underneath the SmartLine element frame must be smooth and even. If they are not, the SmartLine element will not sit flush with the worktop and the sealing strip underneath the top part of the appliance will not provide a good seal between the appliance and the worktop.

Installing several SmartLine elements

The gaps between the individual SmartLine elements are sealed with a silicone sealant that is heat-resistant to at least 160 °C. With flush-fit installation, the gap between the SmartLine element(s) and the worktop must also be sealed with a silicone sealant that is heat-resistant to at least 160 °C.





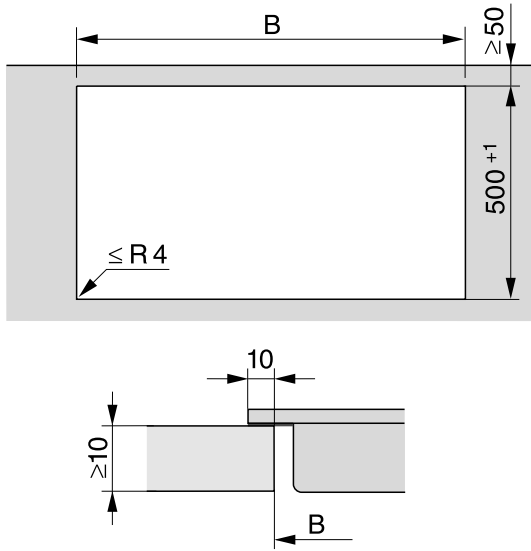

After installation, the SmartLine elements must be easily accessible from below, so that the bottom half of the casing can be removed for maintenance. If the SmartLine elements are not accessible from below, the sealant must be removed so that they can be removed.

Installation

Worktop cutout – surface-mounted

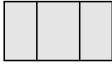

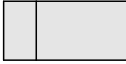
Installation

Combination examples	Number x width [mm] Cooking elements	Dimension B [mm]
	1 x 288	268 ⁺¹
	2 x 288	558 ⁺¹
	1 x 288 1 x 378	648 ⁺¹
	2 x 288 1 x 378	938 ⁺¹
	1 x 288 1 x 620	890 ⁺¹
	2 x 288 1 x 620	1180 ⁺¹
	1 x 288 1 x 800	1070 ⁺¹
	2 x 288 1 x 800	1360 ⁺¹

Installation

Spacer bars – surface-mounted

If you are installing several elements, you must fit spacer bars between them.

The clips supplied with the spacer bars are only required for installing a CSDA 700x FL.

Installing 3 elements and 2 spacer bars

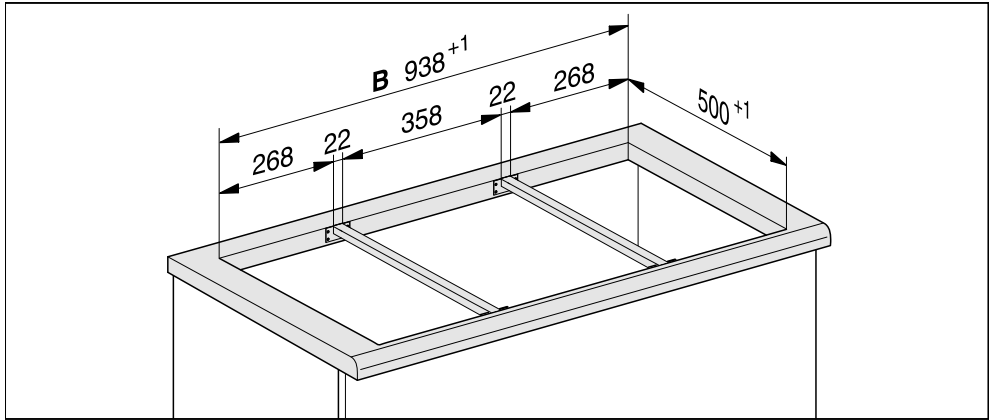

Installation

Installation – surface-mounted

Preparing the worktop

- Create the worktop cutout.
Remember to maintain the minimum safety distances (see “Installation – Safety distances”).
- Seal any cut surfaces on **wooden worktops** with a special varnish, silicone sealant or resin to prevent the wood from swelling as a result of moisture ingress. The sealant must be heat-resistant.

Make sure that the sealant does not come into contact with the top of the worktop.

Wooden worktops

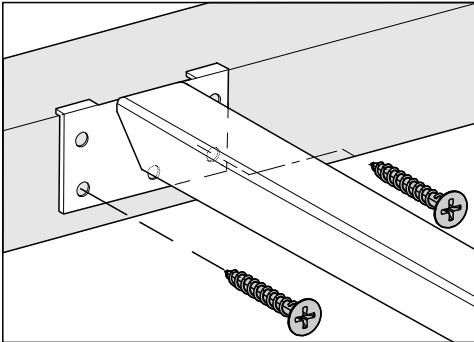

- Position the spacer bars flush onto the upper edge of the cutout.
- Secure the spacer bars with the 3.5 x 25 mm wood screws supplied.

Natural stone worktops

You will need heavy-duty double-sided tape (not supplied) to secure the spacer bars.

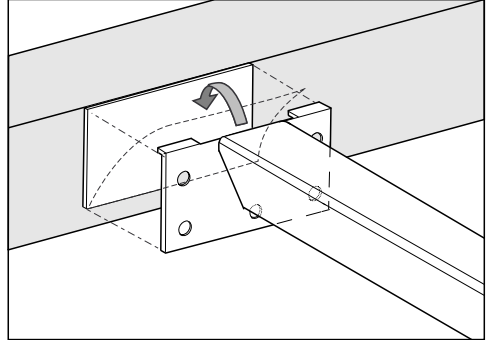

- Stick the tape along the top edge of the worktop cutout.
- Position the spacer bars flush onto the upper edge of the cutout.
- Press the spacer bars firmly into place.

Installing the SmartLine element

- Stick the supplied sealing strip under the edge of the SmartLine element. Do not apply the sealing strip under tension.
- Feed the mains connection cable down through the worktop cutout.
- Position the SmartLine element in the worktop cutout. Ensure that:
 - The seal of the appliance sits flush with the worktop on all sides to ensure an effective seal all round.
 - All gap widths are uniform.
- If the seal does not meet the worktop correctly on the corners, carefully scribe the corner radii ($\leq R4$) with a jigsaw.

Do not use any additional sealant (e.g. silicone) on the SmartLine element.

- Connect the SmartLine element to the mains electricity supply.
- If required, connect the SmartLine element to the gas supply (see “Installation – Gas connection”).
- Check that the SmartLine element works.
- Seal the gaps between the individual elements with a silicone sealant that is heat-resistant to at least 160 °C.

Unsuitable sealant can damage natural stone.

For natural stone worktops and natural stone tiles, only use silicone sealant that is specially formulated for natural stone. Follow the manufacturer’s instructions.

Functional check

- After installing the hob, ignite all burners to check that they are operating correctly:
 - The flame must not go out on the lowest setting, or when the control is turned quickly from the highest to the lowest setting.
 - On the highest setting, the flame must have a distinctive and visible core.

Installation

Installation notes – flush-fit

Flush-fit installation is only possible in natural stone (granite, marble), solid wood and tiled worktops. For installation in worktops made of other materials, please consult the relevant manufacturer as to whether their worktops are suitable for flush-fit installation.

The internal width of the base unit underneath the appliance must be at least as wide as the inner worktop cutout (see “Installation – Building-in dimensions – flush-fit”), so that the SmartLine element is easily accessible from underneath after installation and the bottom half of the casing can be removed for maintenance. If the element is not freely accessible from below after installation, the sealant must be removed so that the element can be removed.

Natural stone worktops

The SmartLine element is set directly in the cutout.

Solid wood worktops, tiled worktops, glass worktops

The SmartLine element is set on a wooden frame inside the cutout. The frame must be provided on site, and is not supplied with the appliance.

Installing several SmartLine elements

The gaps between the individual SmartLine elements are sealed with a silicone sealant that is heat-resistant to at least 160 °C. With flush-fit installation, the gap between the SmartLine element(s) and the worktop must also be sealed with a silicone sealant that is heat-resistant to at least 160 °C.

After installation, the SmartLine elements must be easily accessible from below, so that the bottom half of the casing can be removed for maintenance. If the SmartLine elements are not accessible from below, the sealant must be removed so that they can be removed.

Installation



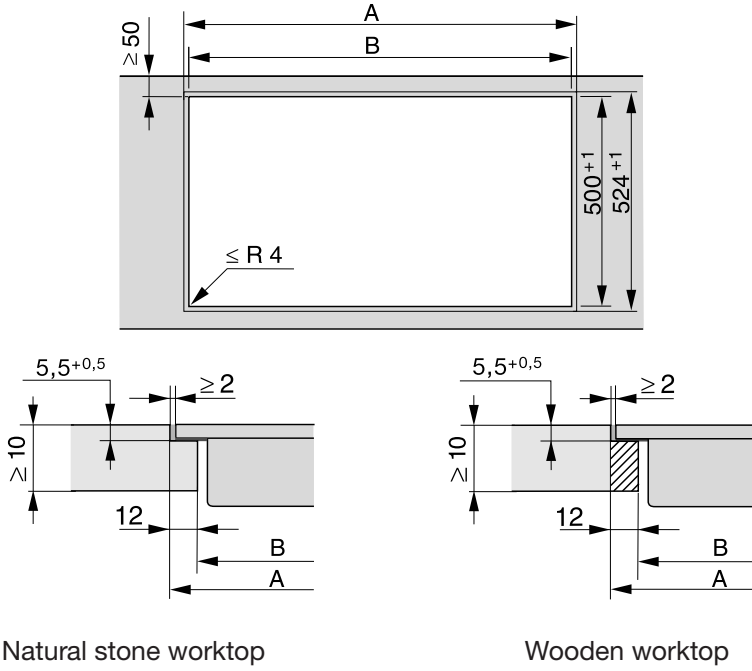





Worktop cutout – flush-fit

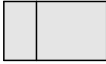

Natural stone worktop

Wooden worktop

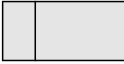
Installation

Combination examples	Number x width [mm] Cooking elements	Dimensions [mm]	
		A	B
	1 x 288	292 ⁺¹	268 ⁺¹
	2 x 288	582 ⁺¹	558 ⁺¹
	1 x 288 1 x 378	672 ⁺¹	648 ⁺¹
	2 x 288 1 x 378	962 ⁺¹	938 ⁺¹
	1 x 288 1 x 620	914 ⁺¹	890 ⁺¹
	2 x 288 1 x 620	1204 ⁺¹	1190 ⁺¹
	1 x 288 1 x 800	1094 ⁺¹	1070 ⁺¹
	2 x 288 1 x 800	1384 ⁺¹	1360 ⁺¹

Installation

Spacer bars – flush-fit

If you are installing several elements, you must fit spacer bars between them.

The clips supplied with the spacer bars are only required for installing a CSDA 700x FL.

Installing 3 elements and 2 spacer bars

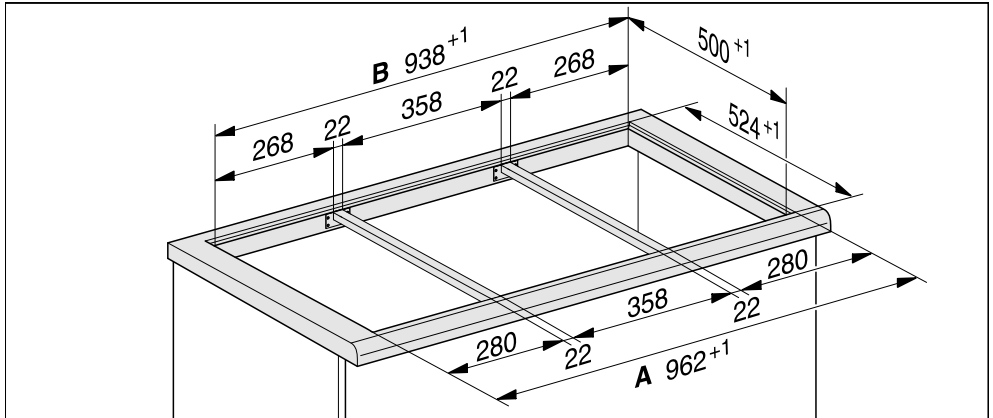

Installation

Installation – flush-fit

Preparing the worktop

- Create the worktop cutout.
Remember to maintain the minimum safety distances (see “Installation – Safety distances”).
- Seal any cut surfaces on **wooden worktops** with a special varnish, silicone sealant or resin to prevent the wood from swelling as a result of moisture ingress. The sealant must be heat-resistant.

Make sure that the sealant does not come into contact with the top of the worktop.

Wooden worktops

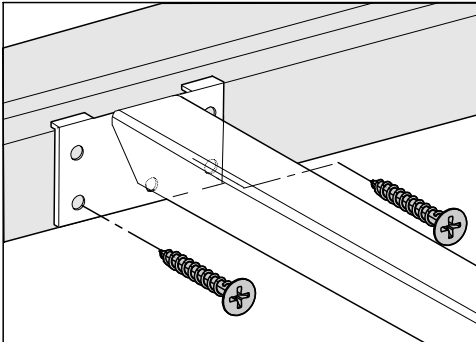

- Position the spacer bars flush onto the lower step of the stepped cutout.
- Secure the spacer bars with the 3.5 x 25 mm wood screws supplied.

Natural stone worktops

You will need heavy-duty double-sided tape (not supplied) to secure the spacer bars.

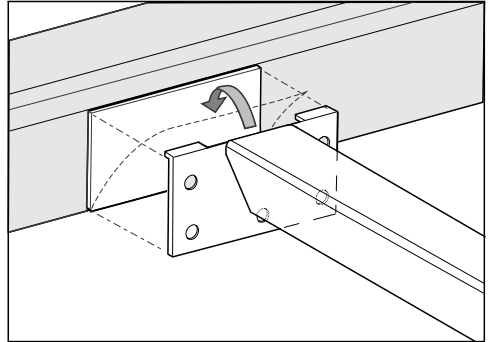

- Stick the tape onto the lower step of the stepped cutout.
- Position the spacer bars flush onto the lower step of the stepped cutout.
- Press the spacer bars firmly into place.

Installing the SmartLine element

- Stick the supplied sealing strip under the edge of the SmartLine element. Do not apply the sealing strip under tension.
- Feed the mains connection cable down through the worktop cutout.
- Position the SmartLine element in the worktop cutout. Ensure that:
 - The seal of the appliance sits flush with the worktop on all sides to ensure an effective seal all round.
 - All gap widths are uniform.
- Connect the SmartLine element to the mains electricity supply.
- If required, connect the SmartLine element to the gas supply (see “Installation – Gas connection”).
- Check that the SmartLine element works.
- Seal the gaps between the individual elements and between the elements and the worktop with a silicone sealant that is heat-resistant to at least 160 °C.

Unsuitable sealant can damage natural stone.

For natural stone worktops and natural stone tiles, only use silicone sealant that is specially formulated for natural stone. Follow the manufacturer’s instructions.

Functional check

- After installing the hob, ignite all burners to check that they are operating correctly:
 - The flame must not go out on the lowest setting, or when the control is turned quickly from the highest to the lowest setting.
 - On the highest setting, the flame must have a distinctive and visible core.

Installation

Gas connection

 Attention! According to the Gas Safety Ordinance of Hong Kong, any gas installation works including the installation of appliances and connection tubing, must be undertaken by registered gas installers who are registered for that appropriate classes and be employed by registered gas contractors.

Use approved gas tubing bearing EMSD approval marking (such as: 機電工程署批准 EMSD APPROVAL GTXXXX) for connection to appliances, or other appropriate methods accepted by EMSD.

The gas connection must be installed so that connection can be made either from inside or outside the kitchen unit. The isolating valve must be easily accessible and visible (by opening the kitchen door if necessary).

Check with your local gas supplier about the type of gas its calorific value and compare this information with the type of gas quoted on the appliance's data plate.

This hob is not connected to an exhaust flue.
When installing and connecting the appliance please observe all relevant installation instructions and ensure it has adequate ventilation once installed.

Connection to the gas supply must be carried out in strict accordance with current local regulations. Every appliance should have its own easily accessible isolating valve and test point.

Any special local conditions relating to gas installations as well as building regulations must also be observed.

Gas connections, pipes and connection cables can suffer damage if exposed to heat from the hob.
After installation make sure that neither the gas pipe nor the mains cable can come into contact with hot parts of the appliance and that the gas pipe and connections on the hob cannot come into contact with hot gas exhaust.

Flexible gas pipes can be damaged by incorrect routing.
Attach flexible gas pipes in such a way so that they do not come into contact with any moving kitchen parts (e.g. a drawer) and are not exposed to mechanical stress.

The hob must be set for local gas conditions and the gas connection must undergo a leakage test.

This appliance is set up for connection to HK liquefied petroleum gas (HKLPG) or HK town gas (HKTG) (see label on the appliance).

Appliances set up for connection to HK town gas have an external gas governor MDG ELITRE (model-no. EL-130, pressure setting at 12.5 mbar) included.

Connection Pressure

HK Town Gas	12.5 mbar
HK Liquefied Petroleum Gas	29 mbar

Connecting the hob

The hob is supplied with a conical 1/2" gas connection point for connection to one of the following:

- Rigid connection with isolation valve
- Flexible connection, maximum length 2000 mm.

Unsuitable sealants may not be leak-proof.

Connections must be sealed using appropriate sealant.

Use approved gas tubing bearing EMSD approval marking (such as: 機電工程署批准 EMSD APPROVAL GTXXXX) for connection to appliances, or other appropriate methods accepted by EMSD.

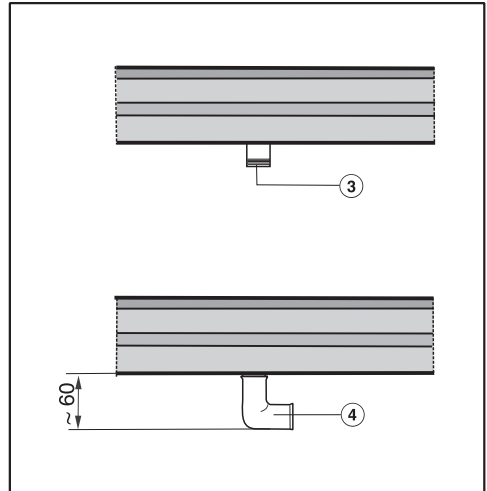

③ Gas connection R 1/2"

④ 90° bend

⚠ Attention! According to the Gas Safety Ordinance of Hong Kong, any gas installation works including the installation of appliances and connection tubing, must be undertaken by registered gas installers who are registered for that appropriate classes and be employed by registered gas contractors.

Installation

Burner ratings

Nominal ratings

Burner	Gas type	Highest setting		Lowest setting
		kW	g/h	kW
Medium burner	HK Town Gas	1.90	–	0.55
	HK Liquefied Petroleum Gas	1.80	131	0.50
Large burner	HK Town Gas	3.20	–	0.75
	HK Liquefied Petroleum Gas	3.00	219	0.75
Total	HK Town Gas	5.10	–	–
	HK Liquefied Petroleum Gas	4.80	349	–

Electrical connection

The SmartLine element is supplied with a mains cable with moulded plug ready for connection to a suitable earthed socket.

The socket must be easily accessible after the SmartLine element has been installed. If the socket is not easily accessible, ensure that a suitable means of disconnection is provided on the installation side for each pole.

 Risk of fire from overheating. Connecting the SmartLine element to multi-socket adapters or extension cables can overload the cables. For safety reasons, do not use an extension cable or multi-socket adapter.

The electrical installation must comply with Electricity (Wiring) Regulations requirements.

For safety reasons, we recommend using a type  residual current device (RCD) in the relevant electrical installation for connecting the SmartLine element.

If the mains connection cable is damaged, it must only be replaced with a specific mains connection cable of the same type (available from the Miele Customer Service Department). For safety reasons, such replacement may only be carried out by a qualified specialist or the Miele Customer Service Department.

These operating instructions and the data plate indicate the nominal power consumption and the appropriate fuse rating. Compare this information with the data of the on-site electrical connection.

If in any doubt, consult a registered electrical worker.

Temporary or permanent operation on an autonomous power supply system or a power supply system that is not synchronised with the mains power supply (e.g. island networks, back-up systems) is possible. A prerequisite for operation is that the power supply system complies with the specifications of EN 50160 or an equivalent standard. The function and operation of the protective measures provided in the domestic electrical installation and in this Miele product must also be maintained in isolated operation or in operation that is not synchronised with the mains power supply, or these measures must be replaced by equivalent measures in the installation. As described, for example, in the current version of BS OHSAS 18001–2 ISO 45001.

Technical Data

Model No CS 7152 FL

Cut-out dimensions

Surface-mounted

Width 268 mm

Depth 500 mm

Flush

Width inner cut-out 268 mm

Depth inner cut-out 500 mm

Width outer cut-out 292 mm

Depth outer cut-out 524 mm

Build-in depth 84 mm

(Allow additional space below for connection to the gas supply)

Unit Dimensions

Width 288 mm

Depth 520 mm

Electrical connection

Voltage 220–240 V

Fuse rating 13 A

Gas Type

HK Town Gas
(with external gas governor)

HK Liquefied
Petroleum Gas

Connection Pressure

12.5 mbar/1.25 kPa

29 mbar/2.9 kPa

Rated Heat Input

Medium burner 1.90 kW

1.80 kW

Large burner 3.20 kW

3.00 kW

Hong Kong, China**Miele (Hong Kong) Ltd.**

41/F - 4101, Manhattan Place

23 Wang Tai Road

Kowloon Bay

Hong Kong

Tel: (852) 2610 1025

Fax: (852) 3579 1404

E-mail: customerservices@miele.com.hk

Website: www.miele.hk

Miele Experience Centre

G/F & 1/F, Lee Garden Six

111 Leighton Road

Causeway Bay

Hong Kong

Tel: (852) 2890 1018

Fax: (852) 3579 1401

E-mail: ExperienceCentre@miele.com.hk

International Head Office

Miele & Cie. KG

Carl-Miele-Straße 29

33332 Gütersloh

Germany

Hong Kong, China**Miele (Hong Kong) Ltd.**

香港九龍灣宏泰道23號

Manhattan Place 41樓4101室

電話: (852) 2610 1025

傳真: (852) 3579 1404

電郵地址: customerservices@miele.com.hk

網址: www.miele.hk

Miele 陳列室

香港銅鑼灣禮頓道111號利園6期地下及一樓

電話: (852) 2890 1018

傳真: (852) 3579 1401

電郵地址: ExperienceCentre@miele.com.hk

CS 7152 FL

en-HK

M.-Nr. 12 166 520 / 00