

de - Montageplan für vollintegrierte Geschirrspüler

Bitte beachten Sie diesen Montageplan und lesen Sie unbedingt die Gebrauchsanweisung vor der Aufstellung - Installation - Inbetriebnahme.
Dadurch schützen Sie sich und vermeiden Schäden an Ihrem Gerät.

en - Installation drawings for fully integrated dishwashers

To avoid the risk of accidents or damage to the dishwasher please observe this installation sheet and read the operating instruction manual supplied with it before it is installed or used for the first time.

fr - Notice de montage pour lave-vaisselle totalement intégrables

Pour votre sécurité et afin d'éviter d'endommager votre appareil, veuillez suivre les indications de cette notice et lire le mode d'emploi avant de monter, d'installer ou de mettre en service votre lave-vaisselle.

nl - Installatietekening voor volledig geïntegreerde vaatwassers

Bekijk dit montageschema en lees de gebruiksaanwijzing voordat u uw apparaat plaatst, installeert en in gebruik neemt.
Dat is veiliger voor uzelf en u voorkomt daarmee onnodige schade aan uw apparaat.

it - Schema di montaggio per lavastoviglie a scomparsa totale

Prima di installare e mettere in funzione la lavastoviglie, leggere assolutamente le istruzioni per l'uso e attenersi a questo schema di montaggio per evitare di farsi male o di danneggiare l'elettrodomestico.

es - Plano de montaje para lavavajillas totalmente integrables

Le agradecemos su confianza y esperamos disfrute de su nuevo aparato.
Para ello es imprescindible, antes de su emplazamiento, instalación y puesta en marcha, tener en cuenta este esquema de montaje y leer las instrucciones de manejo, para evitar daños tanto al usuario, como al aparato.

pt - Plano de montagem para máquinas de lavar louça de integrar

Observe este plano de montagem e leia as instruções de utilização antes de instalar, ligar e iniciar o funcionamento com a máquina.
Esta forma não só se protege como evita anomalias no seu aparelho.

tr - Tam Ankastré Bulaşık Makinesi Montaj Planı

Bu montaj planını dikkate alınız ve cihazı kurmadan ve çalıştırmadan önce kullanma kılavuzunu mutlaka okuyunuz.



Wasserablauf belüften

Wenn der Abwasserlauf tiefer liegt als die Führung für die Rollen des Unterkorbes in der Tür, muss der Wasserablauf belüftet werden.

Venting the water drain

If the on-site drainage connection is situated lower than the guide path for the lower basket rollers in the open door, the drainage system must be vented.

Purger la vidange d'eau

Si le raccord domestique de vidange est placé plus bas que les guides pour les roulettes du panier inférieur dans la porte, la vidange doit être mise à l'air.

Waterafvoer beluchten

Wanneer de waterafvoeraansluiting ter plaatse lager ligt dan de geleiding voor de wieljes van het onderrek in de deur, moet de waterafvoer worden belucht.

Sfiatare lo scarico idrico

Se l'allacciamento per lo scarico dell'acqua in loco si trova più in basso rispetto alla guida delle rotelle del cesto inferiore nello sportello, si deve sfiatare lo scarico.

Purgado del desagüe

Será necesario purgar el desagüe si la conexión del mismo estuviera situada a menor altura que la guía de las ruedas del cesto inferior en la puerta.

Ventilar o esgoto da água

Se a ligação para o esgoto da água existente no local se situar num nível mais baixo do que a calha onde o cesto inferior desliza, é necessário efetuar a ventilação do esgoto da água.

Su giderinin havalandırılması

Kurulum yerindeki su gideri bağlantısı, kapaktaki alt sepet tekerlekleri kılavuzundan daha alçaktaysa, su çıkışının havalandırılması gerekir.



Gebrauchsanweisung beachten.

See operating instruction manual.

Lisez le mode d'emploi.

Neem de gebruiksaanwijzing in acht.

Attenersi alle istruzioni d'uso.

Tenga en cuenta las instrucciones de manejo.

Observe o indicado no livro de instruções.

Kullanma kılavuzunu dikkate alınız.



Beschädigung oder Brandgefahr.

Risk of damage or fire hazard.

Risque de dommages ou d'incendie.

Gevaar voor schade of brand.

Attenzione: pericolo di danneggiamento o di incendio.

Daños o riesgo de incendio.

Risco de avarias ou de incêndio.

Hasar veya yangın tehlikesi.



Anschlusswerte beachten.

Check connection data.

Respectez les valeurs de raccordement.

Neem de aansluitwaarden in acht.

Controllare i valori di allacciamento.

Atégase a los valores de conexión.

Observe os valores para a ligação.

Bağlantı değerlerine dikkat ediniz.

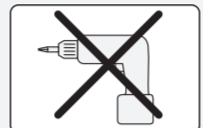

Keinen Akkuschauber verwenden, Beschädigungsgefahr.

Do not use a cordless screwdriver, risk of damage.

N'utilisez pas de visseuse électrique, risque de dommages.

Gebruik geen accuschroevendraaier. Kans op beschadiging.

Non utilizzare un avvitatore a batteria, pericolo di danneggiamento.

No utilizar destornillador automático, peligro de sufrir daños.

Não usar aparafusadoras sem fios, risco de danos.

Şarjlı tornavida kullanmayınız, hasar tehlikesi.



Vor dem Verschieben des Geschirrspülers FüÙe eindrehen.

Screw the feet in before moving the dishwasher.

Faire entrer les pieds en les vissant avant de déplacer la lave-vaisselle.

Draai de stelvoeten naar binnen voordat u de vaatwasser verschuift.

Avvitare i piedini prima di muovere la lavastoviglie.

Antes de deslizar el lavavajillas, atornillar las patas.

Antes de deslocar a máquina de lavar louça deve enroscar os pés.

Bulaşık makinesini yerinden oynatmadan önce vidalı ayakları içeri çeviriniz.



Achtung Schnittgefahr.

Warning: Danger of being cut.

Attention. Risque de blessure par coupure.

Pas op. Snijgevaar.

Attenzione, pericolo di tagliarsi.

Atención. Peligro de cortes.

Atenção. Risco de ferimentos por corte.

Dikkat Kesik Tehlikesi.



Türfedern nach Montage der Frontplatte unbedingt auf beiden Seiten gleichmäßig einstellen.

The door springs must be set equally on both sides after fitting the front panel to the door.

Les ressorts de porte doivent impérativement être réglés de la même façon des deux côtés après le montage de la plaque d'habilage.

Het is beslist noodzakelijk dat u de deurveren na de montage van het frontpaneel aan beide kanten gelijkmatig instelt.

El peso mínimo/máximo del panel frontal se puede encontrar en los datos técnicos del lavavajillas en la página web de Miele.

Pode encontrar o peso mínimo/máximo dos painéis frontais nas características técnicas da sua máquina de lavar louça no site da Miele.

Minimum/maksimum ön panel ağırlığını, Miele web sitesinde, bulaşık makinesinin teknik verilerinde bulabilirsiniz.



Das minimale/maximale Frontplattengewicht finden Sie unter den Technischen Daten Ihres Geschirrspülers auf der Miele Internetseite.

The minimum/maximum weight of the front panel is quoted in the technical data for your dishwasher on the Miele website.

Vous trouverez le poids minimal/maximal du panneau de façade dans les caractéristiques techniques de votre lave-vaisselle sur le site Internet de Miele.

Het minimale/maximale gewicht van de frontplaat vindt u bij de technische gegevens van uw vaatwasser op de website van Miele.

El peso mínimo/máximo relativo al pannelo frontale è indicato sotto i dati tecnici della lavastoviglie, sul sito internet di Miele.

Después del montaje del aparato, ajustar equitativamente los muelles de la puerta a ambos lados.

Após montagem do painel frontal, regular as molas da porta uniformemente de ambos os lados.

Ön kapak takıldıktan sonra kapak yayları her iki tarafta da mutlaka eşit ayarlanmalıdır.

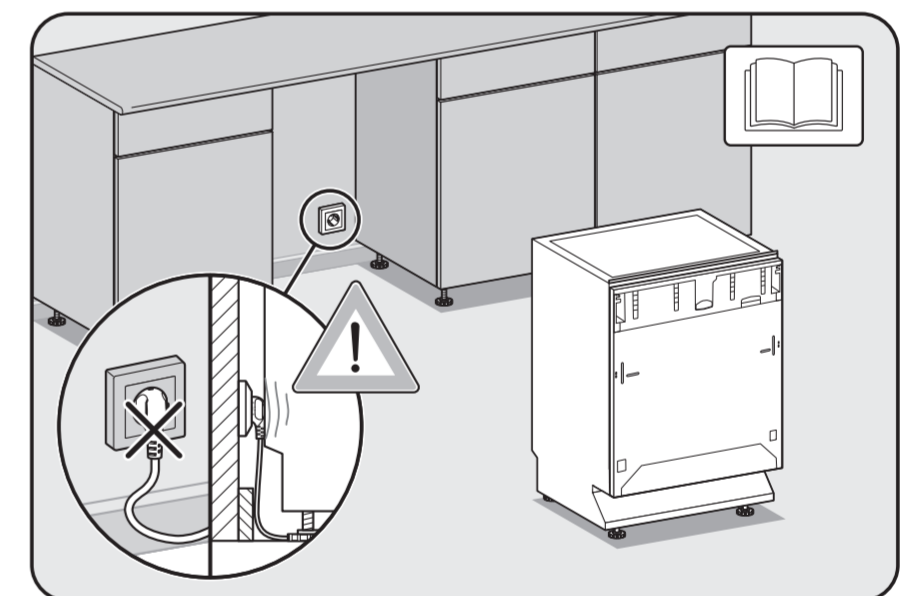
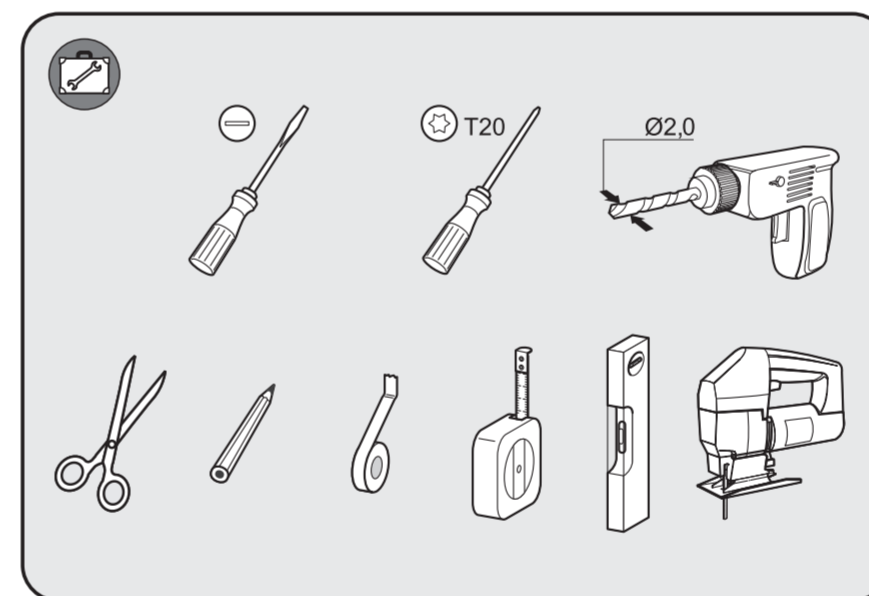
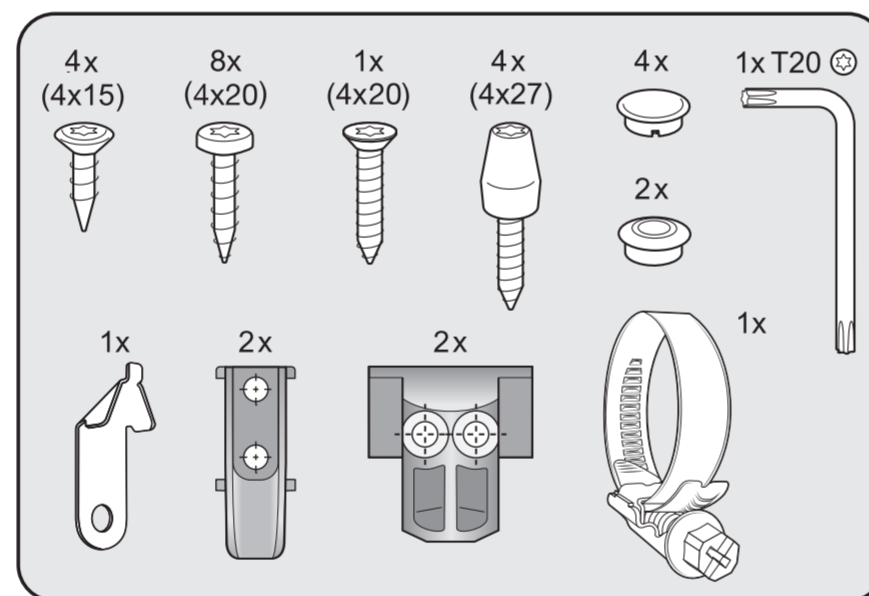
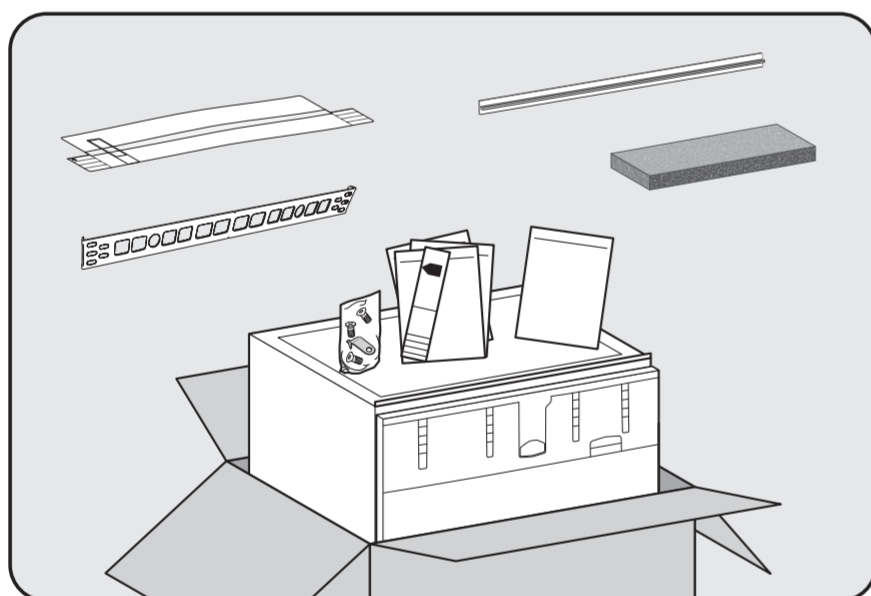

Je nach Modell benötigtes Werkzeug.
Tools required depend on model.
Matériaux requis selon modèle.
Voor het desbetreffende model benodigd gereedschap.

Utensili necessari, a seconda del modello.
Según el modelo, herramienta necesaria.
De acordo com o modelo, ferramentas necessárias.
Modèle bağlı olarak gerekli aletler.

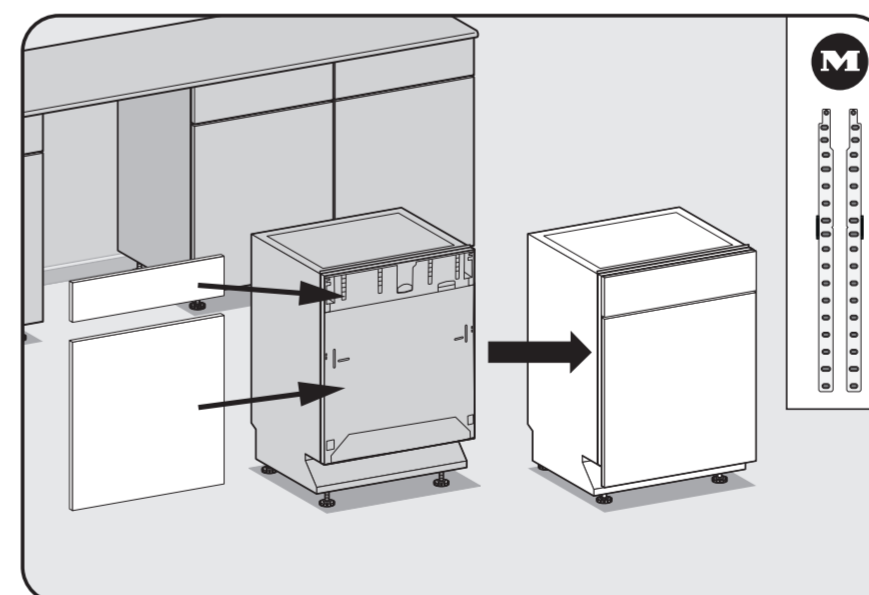
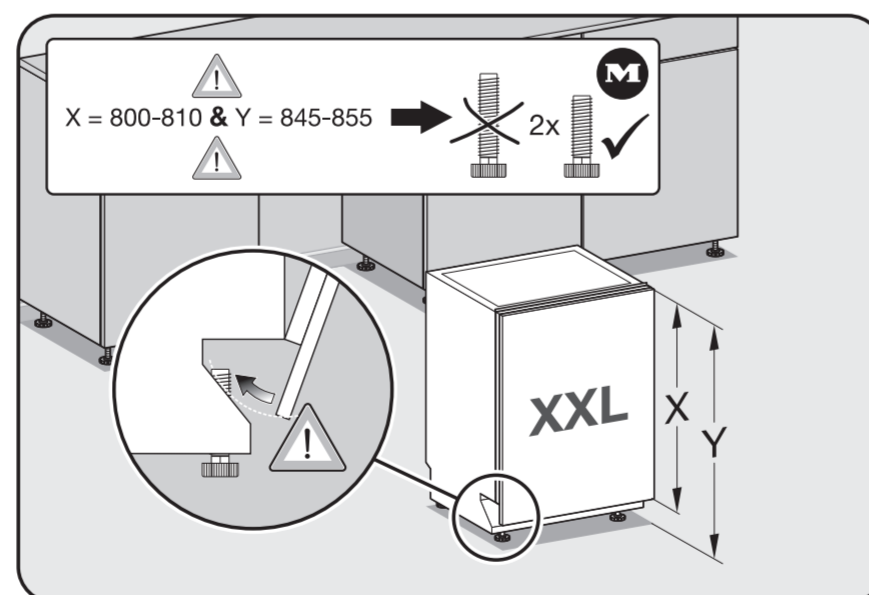
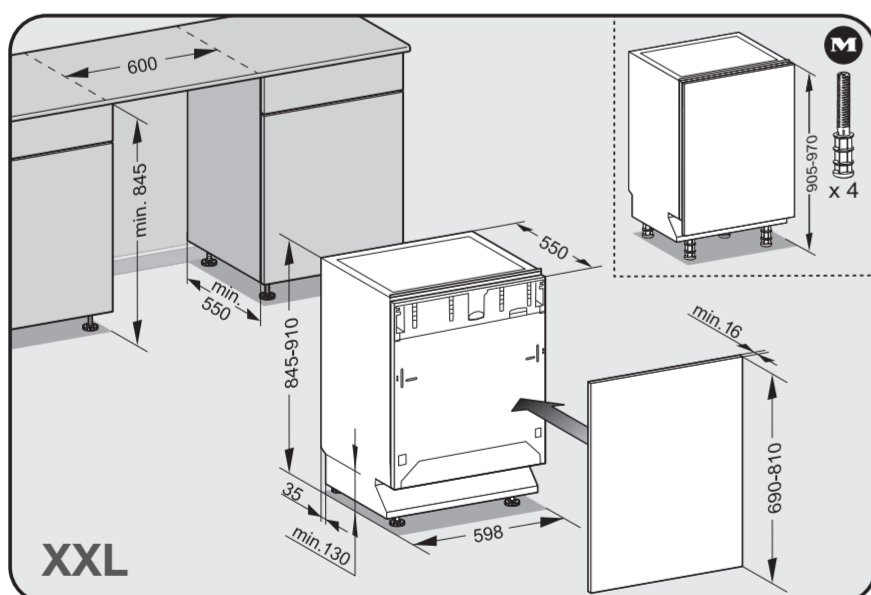

M Nachkaufbares Zubehör
Optional accessories
Accessoires en option
Na te bestellen accessoire
Accessorio su richiesta

Accesorio especial
Accesorio que puede adquirir
Sonradan alınabilen aksesuar

