

Operating and Installation Instructions Gas cooktop

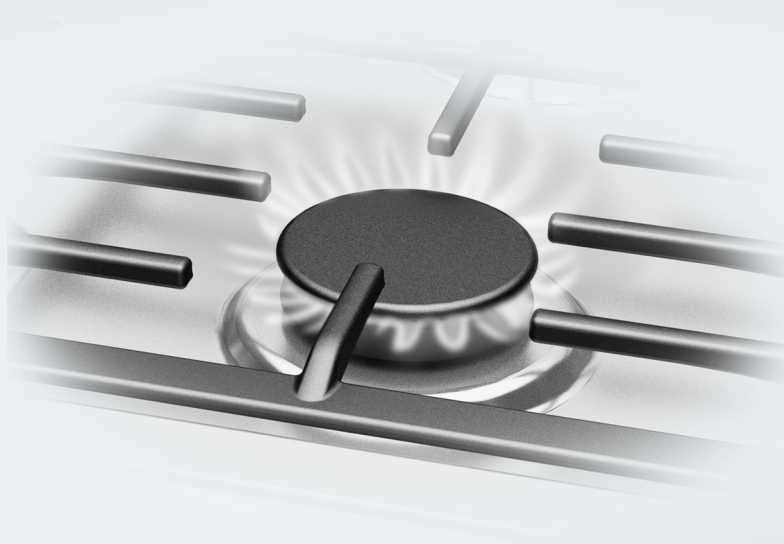

To prevent accidents and damage to the range, you **must** read all instructions supplied before installing or using the appliance.

IMPORTANT SAFETY INSTRUCTIONS

⚠ WARNING: If the information in this manual is not followed exactly, a fire or explosion may result causing property damage, personal injury, or death.

- Do not use or store gasoline or other combustible liquids or vapors in the vicinity of this or any other appliance.
- **WHAT TO DO IF YOU SMELL GAS**
 - Do not try to light any appliance.
 - Do not touch any electric switches.
 - Do not use any phones inside your building.
 - Immediately call your gas supplier from a neighbor's phone. Follow the gas supplier's instructions.
 - If you are unable to reach your gas provider, call the fire department.
- Installation and service must be performed by a qualified installer, qualified service agency or your gas provider.
(In Massachusetts, installation must be performed by a licensed installer / gas fitter.)
- Note to the installer:
Please give these installation instructions to the consumer for the local electrical/gas inspector.

⚠ WARNING: Never Operate the Top Surface Cooking Section of this Appliance Unattended.

- Failure to follow this warning statement could result in fire, explosion, or burn hazard that could cause property damage, personal injury, or death.
- If a fire should occur, keep away from the appliance and immediately call your fire department.

DO NOT ATTEMPT TO EXTINGUISH AN OIL/GREASE FIRE WITH WATER.



IMPORTANT SAFETY INSTRUCTIONS	2
IMPORTANT SAFETY INSTRUCTIONS	5
Caring for the environment	14
Overview	15
Your cooktop	15
KM 2012	15
KM 2032	16
Control knobs.....	17
Burner.....	18
Included accessories	18
Initial commissioning	20
Cleaning the cooktop for the first time	20
Turning on the cooktop for the first time	20
Cookware	21
Energy saving tips	22
Operation	23
Turning the appliance on	23
Adjusting the flame	24
Switching off	24
Safety features	25
Cleaning and care	26
Cleaning the stainless-steel cooktop	27
Cleaning the grates	28
Cleaning the knobs.....	28
Cleaning the burner.....	29
Assembling the burner.....	30
Frequently asked questions	32
Optional accessories	34
Customer Service	35
Contact in the event of a fault	35
Appliance warranty and product registration	35
Installation	36
IMPORTANT SAFETY INSTRUCTIONS - INSTALLATION	36
Safety distances	37
Installation notes	38

Contents

Installation dimensions	39
KM 2012	39
KM 2032	40
Installation.....	42
Gas connection.....	44
Burner ratings	47
Electrical connection	48

IMPORTANT SAFETY INSTRUCTIONS

This cooktop complies with all relevant local and national safety requirements. Inappropriate use can, however, lead to personal injury and material damage.

Read the operating and installation instructions carefully before using the cooktop. They contain important information on safety, installation, use, and maintenance. This prevents both personal injury and damage to the cooktop.

In accordance with standard IEC 60335-1, Miele expressly and strongly advises that you read and follow the instructions in the chapter on installing the cooktop as well as in the “IMPORTANT SAFETY INSTRUCTIONS”.

Miele cannot be held liable for injury or damage caused by non-compliance with these instructions.

Keep these instructions in a safe place and pass them on to any future owner.

Appropriate use

- ▶ This cooktop is intended for domestic use and use in other similar environments.
- ▶ This cooktop is not intended for outdoor use.
- ▶ The cooktop is intended for domestic use only to prepare food and keep it warm. Any other use may be dangerous.
- ▶ Persons (including children) who lack physical, sensory or mental abilities, or experience with the appliance should not use it without supervision or instruction by a responsible person.

IMPORTANT SAFETY INSTRUCTIONS

Safety with children

- ▶ Do not leave children unattended: Children should not be alone or unsupervised in the area where the appliance is installed. Do not allow them to sit or stand on the appliance.
- ▶ Children should be supervised in the vicinity of the cooktop. Never allow children to play with the cooktop.
- ▶ The cooktop gets hot when in use and remains hot for some time after being turned off. Keep children away from the appliance until it has cooled down and is no longer a burn hazard.
- ▶ Danger of burning. Do not store anything which might arouse a child's interest in storage areas above or behind the cooktop. Otherwise they could be tempted to climb onto the cooktop.
- ▶ Risk of burning or scalding. Turn pot and pan handles inward, so children cannot pull them down and be burned.
- ▶ Danger of suffocation. While playing, children may become entangled in packaging material (such as plastic wrapping) or pull it over their head, presenting the risk of suffocation. Keep packaging material away from children.

IMPORTANT SAFETY INSTRUCTIONS

Technical safety

- ▶ Unauthorized installation, maintenance, and repairs could result in unforeseen dangers for the user, for which the manufacturer cannot accept liability. Installation, maintenance, and repairs should only be carried out by a qualified specialist or Miele Service.
- ▶ Maintenance by the user: Never repair or replace any part of the appliance unless the instructions specifically recommend doing so. Service work should only be performed by a qualified technician.
- ▶ Damage to the cooktop can compromise your safety. Check the cooktop for visible signs of damage. Do not use the cooktop if it is damaged.
- ▶ Temporary or permanent operation on an autonomous power supply system or a power supply system that is not synchronized with the grid power supply (e.g., island networks, back-up systems) is possible. A prerequisite for operation is that the power supply system complies with national and local codes.
The function and operation of the protective measures provided in the domestic electrical installation and in this Miele product must also be maintained in isolated operation or in operation that is not synchronized with the grid power supply, or these measures must be replaced by equivalent measures in the installation.
- ▶ The electrical safety of this cooktop can only be guaranteed when correctly grounded. It is essential that this basic safety requirement is fulfilled. If in doubt, the electrical installation should be checked by a qualified electrician.
- ▶ Proper installation: Make sure that your appliance has been installed correctly and that it has been grounded by a qualified technician.
- ▶ The connection data (voltage and frequency) on the data plate of the cooktop must match the power supply in order to avoid the risk of damage to the cooktop.
Compare this data before connecting the appliance. If in any doubt, consult a qualified electrician.
- ▶ Do not connect the appliance to the electrical supply with a power bar or extension cord. These are a fire hazard and do not guarantee the required safety of the appliance.
- ▶ For safety reasons, the cooktop may only be used when it has been fully installed.

IMPORTANT SAFETY INSTRUCTIONS

- ▶ This cooktop must not be used at non-stationary installation sites (e.g., on a ship).
- ▶ Any contact with live connections or tampering with the electrical or mechanical components of the cooktop will endanger your safety and may lead to the cooktop malfunctioning.
Do not open the cooktop housing under any circumstances.
- ▶ Any repairs not performed by a Miele authorized service technician will void the warranty.
- ▶ It is recommended to replace faulty components with original Miele parts. If original Miele parts are installed correctly, Miele ensures full compliance with safety requirements and the warranty remains valid.
- ▶ The appliance is not intended for use with an external timer switch or a remote control system.
- ▶ The connection to the gas supply must be carried out by a qualified service technician in accordance with current local and national safety regulations (see “Installation – Gas connection”). If the plug has been removed or the power cord is not supplied with a plug, the cooktop must be connected to the power supply by a qualified service technician (see “Installation – Electrical connection”).
- ▶ If the power cord is damaged, it must only be replaced by a qualified service technician (see “Installation – Electrical connection”).
- ▶ During installation, maintenance, and repair work, the appliance must be completely disconnected from the household electricity supply. The gas supply must be shut off. Ensure that this is the case by:
 - removing the fuse
 - “tripping” the circuit breaker, or
 - unplugging the unit. Pull the plug not the cord.
 - Shut off the gas supply.
- ▶ Danger of electric shock.
If the cooktop is defective, immediately turn the appliance off and discontinue use. Disconnect it from the electricity and gas supply. Contact Technical Service.

IMPORTANT SAFETY INSTRUCTIONS

- ▶ If the cooktop is installed behind a cabinet (e.g., a door), do not close the cabinet door while the cooktop is in operation. Heat and moisture can build up behind the cabinet door when closed. This can result in damage to the cooktop, housing unit, and floor. Leave the cabinet door open until the cooktop has cooled down completely.
- ▶ Ask your installer to show you the location of your gas shutoff valve and fuses or circuit breaker panel in your apartment or home. Be sure that you know how and where to disconnect the gas and power supply to your cooktop.

IMPORTANT SAFETY INSTRUCTIONS

Correct use

▶ The cooktop gets hot when in use and remains hot for some time after being turned off. Do not touch the appliance if there is a possibility that it could still be hot.

WARNING

NEVER use this cooktop as a space heater to heat or warm the room. Doing so may result in carbon monoxide poisoning and overheating of the appliance.

- ▶ Never leave the appliance unattended at high heat settings – Boilover causes smoking and greasy spillovers that may ignite.
- ▶ Oil and fat can catch fire if overheated. Never leave the appliance unattended when cooking with oil and fat. If the oil or fat catches fire, do not attempt to put the flames out with water. Turn off the cooktop and smother the flames using a lid or a suitable fire blanket.
- ▶ Do Not Use Water on Grease Fires – Smother fire or flame or use dry chemical or foam-type extinguisher.
- ▶ The flames could set the grease filters of a ventilation hood on fire. Do not flambé under a ventilation hood.
- ▶ Spray canisters, aerosols and other inflammable substances can ignite when heated. Therefore do not store such items or substances in a drawer under the appliance. Cutlery inserts must be heat-resistant.
- ▶ Never heat empty cookware.
- ▶ Do not heat or can food in closed containers, such as tins or sealed jars, on the cooktop, as pressure will build up in the container and cause it to explode.
- ▶ If the cooktop is covered, there is a risk that the material of the cover will ignite, explode or melt if the cooktop is still hot or if turned on inadvertently. Never cover the cooktop with a board, cloth or protective sheet.
- ▶ When the appliance is turned on inadvertently or by mistake, or when there is residual heat present, there is a risk of the metal items heating up. Other materials can melt or catch fire when the appliance is switched on. Do not store items on the cooktop.

IMPORTANT SAFETY INSTRUCTIONS

- ▶ You can burn yourself on a hot cooktop. When cooking on the appliance, protect your hands by using heat-resistant pot holders or oven mitts. Only use dry pot holders or gloves. Wet or damp textiles conduct heat more effectively and produce steam, which poses a burn hazard. Be sure to keep all textiles away from the gas flames. Do not use oversized cloths, dish towels or other similar materials.
- ▶ When using an electrical appliance (e.g., a hand mixer) near the cooktop, make sure that the power cord does not come into contact with the hot cooktop. The cord's insulation could become damaged.
- ▶ Cookware made of plastic or aluminum foil will melt at high temperatures. Do not use any plastic or aluminum foil cookware.
- ▶ Pressing the knob generates a spark on the ignitor. Do not press the knob while you are cleaning or touching the cooktop or a burner in the vicinity of an ignitor.
- ▶ A ventilation hood installed above the cooktop can become damaged or catch fire as a result of intense heat. Do not use the burners without cookware.
- ▶ Only light the burners after all burner parts have been properly assembled.
- ▶ If the cookware is too small, it will not sit properly on the burner grate. If the cookware is too large, heat emitted from the bottom of the cookware may damage the countertop, walls with poor heat-resistance (e.g. paneled walls) or portions of the cooktop.
- ▶ Make sure that the burner flames do not extend beyond the bottom of the cookware and rise up its sides.
- ▶ Only use cookware with a thick enough bottom. Failure to do so may result in damage to the cooktop.
- ▶ Always use the burner grates supplied with the cooktop. Never place cookware directly on the burner.
- ▶ Install the burner grates in an upright position to avoid scratching the cooktop.
- ▶ Storage in or on the appliance: Flammable materials should not be stored in an oven or in the vicinity of the appliance.
- ▶ Remove all grease splatters and other flammable (food) residues on the cooktop. They are a fire hazard.
- ▶ Avoid allowing liquids or foods containing salt to spill onto the cooktop. If salty foods or liquids do get on the cooktop, they should be removed as soon as possible to avoid the risk of corrosion.

IMPORTANT SAFETY INSTRUCTIONS

- ▶ Using of a gas cooktop causes heat, moisture and products of combustion to build up in the room in which it is installed. Make sure that your kitchen is well ventilated, especially when the appliance is in use: keep any natural means of ventilation open or install a mechanical ventilation system (e.g. a ventilation hood).
- ▶ If the cooktop is used for very long periods of time, additional ventilation of the room may be necessary, e.g. by opening windows or doors, or running the ventilation on the highest setting.
- ▶ Do not use pots or pans that are large enough to cover several burners. The resulting heat buildup can damage the appliance.
- ▶ If the cooktop has not been used for a long period of time, be sure to thoroughly clean it and have it inspected by an authorized technician before using it again.
- ▶ Ensure that the igniters are clean and dry to allow the burners to ignite and burn properly.
- ▶ Fire hazard! Loose-fitting or hanging garments can catch fire. Be sure to wear appropriately fitting clothing when cooking. Never allow loose clothing or flammable materials to come into contact with the burners while the burners are in use.
- ▶ When you have finished cooking, make sure that the burners are turned off by checking the position of the knobs.
- ▶ The grates, burner cap, bottom parts of the burner, and any other parts located near the burner flame, can still be very hot after cooking and cause burns. Do not touch these components when using the cooktop.
- ▶ Wind can blow curtains over the cooktop, causing them to catch fire. If the cooktop is installed near a window, do not use long curtains.
- ▶ Only certain types of glass, ceramic or other enamel cookware can be used on a gas cooktop without breaking as a result of sudden temperature changes.
- ▶ Wet sponges or cloths can cause burns due to hot steam if they are used to wipe spilled food off a hot cooktop. Some cleansers can emit hazardous vapors if they are applied to a hot surface. Be careful when cleaning the cooktop.

IMPORTANT SAFETY INSTRUCTIONS

Cleaning and maintenance

▶ The steam from a steam cleaner could reach live electrical components and cause a short circuit.

Do not use a steam cleaner to clean the cooktop.

SAVE THESE INSTRUCTIONS AND REVIEW THEM PERIODICALLY

Caring for the environment

Disposal of the packing material

The cardboard box and packing materials protect the appliance during shipping. They have been designed to be biodegradable and recyclable.

Ensure that any plastic wrappings, bags, etc. are disposed of safely and kept out of the reach of children. Danger of suffocation!

Disposal of your old appliance

Electrical and electronic appliances contain valuable materials. They also contain certain substances, compounds and components which were essential for the proper functioning and safe use of the equipment. Handling these materials improperly by disposing of them in your household waste can be harmful to your health and the environment. Therefore, please do not dispose of your old appliance with regular household waste and follow local regulations on proper disposal.



Consult with local authorities, dealers or Miele in order to dispose of and recycle electrical and electronic appliances. Miele assumes no responsibility for deleting any personal data left on the appliance being disposed. Please ensure that your old appliance is kept away from children until removal. Observe safety requirements for appliances that may tip over or pose an entrapment hazard.

Your cooktop

KM 2012

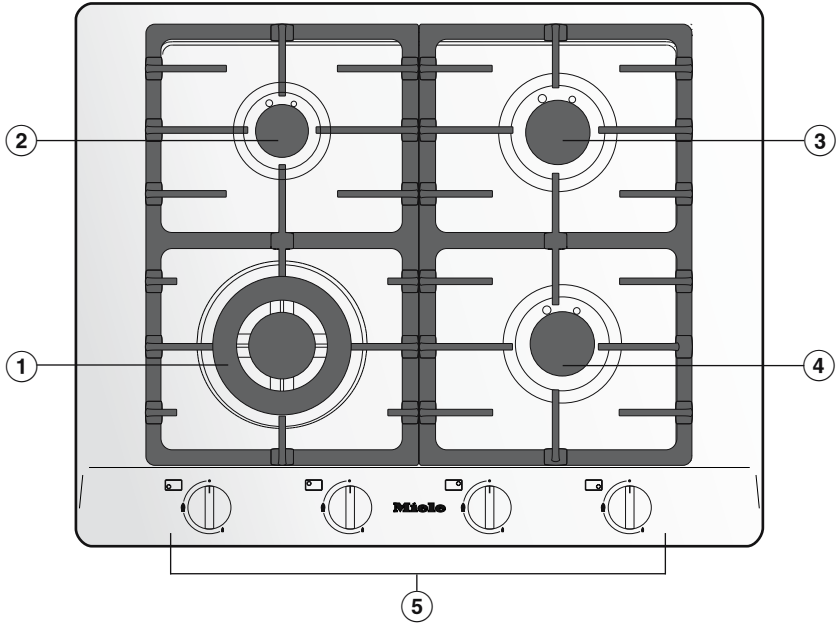

- ① Wok burner
- ② Economy burner
- ③ Normal burner
- ④ Normal burner

Knobs for the cooking zones

- ⑤ Front right
- ⑥ Back right
- ⑦ Back left
- ⑧ Front left

- ⑨ Wok burner
- ⑩ Economy burner
- ⑪ Normal burner
- ⑫ Normal burner
- ⑬ Knobs for burners

Overview

KM 2032

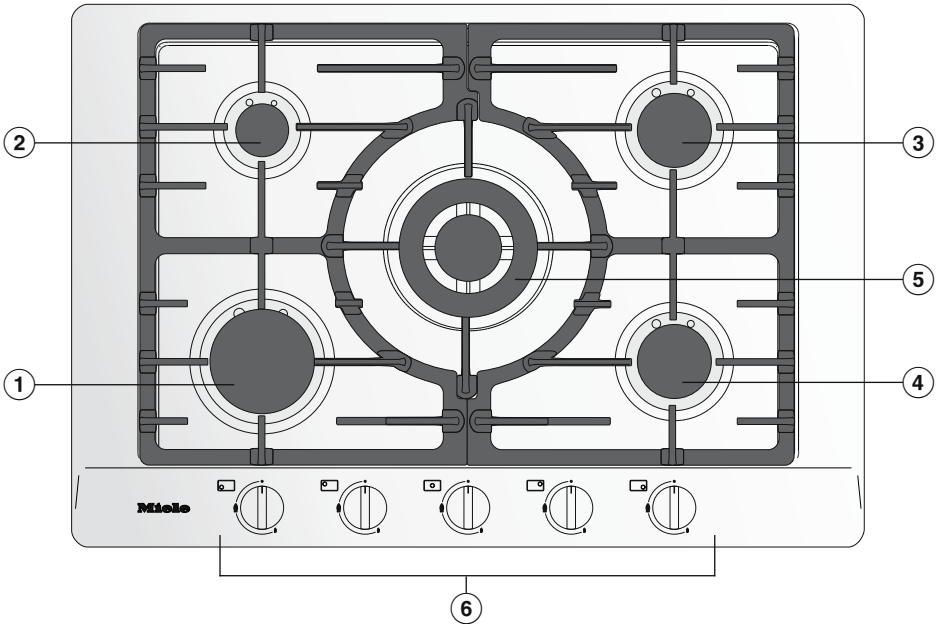

- ① Power burner
- ② Economy burner
- ③ Normal burner
- ④ Normal burner
- ⑤ Wok burner

Knobs for the cooking zones

- ⑥ Front right
- ⑦ Back right
- ⑧ Middle
- ⑨ Back left
- ⑩ Front left

- ⑪ Power burner
- ⑫ Economy burner
- ⑬ Normal burner
- ⑭ Normal burner
- ⑮ Wok burner
- ⑯ Knobs for burners

Control knobs

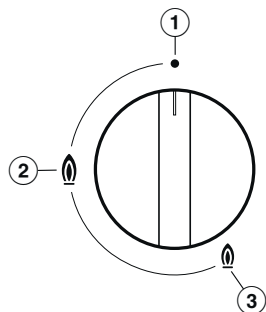

- ① • Burner off
The gas supply is turned off
- ② 🔥 Strong flame
The burner is on the highest setting
- ③ 🔥 Weak flame
The burner is on the lowest setting

Overview

Burner

Wok burner

Wok burner

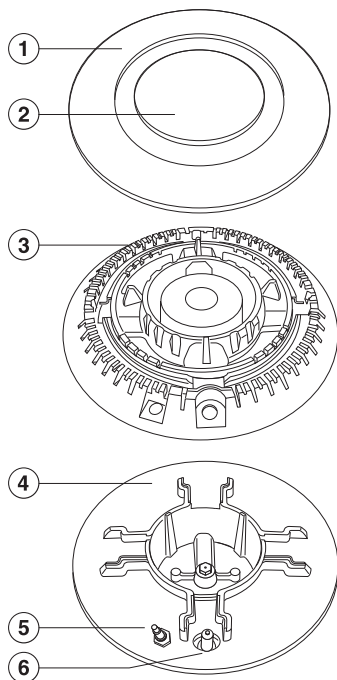

- ① Outer burner cap
- ② Inner burner cap
- ③ Burner head
- ④ Burner base
- ⑤ Thermocouple
- ⑥ Ignitor

Economy, normal, and power burners

Economy, power and normal burners

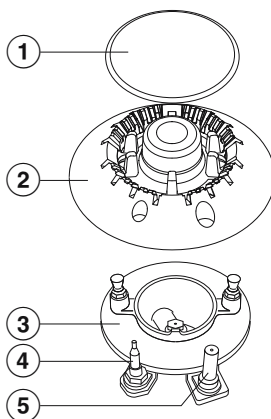

- ① Burner ring (wok burner)
- ② Burner cap
- ③ Burner head
- ④ Burner base
- ⑤ Thermocouple
- ⑥ Ignition electrode
- ⑦ Burner cap

Included accessories

The accessories supplied with your appliance, as well as a range of optional ones, are available to order from Miele (see “Optional accessories”).

Wok ring



The Wok ring supplied with your appliance can be used in instances where extra stability is required. It is particularly suitable for wok pans with rounded bases.

Initial commissioning

Cleaning the cooktop for the first time

- Before first use, wipe down the appliance with a damp cloth and dry it.
- Using a soft sponge, clean all removable burner parts with a solution of warm water and a small amount of liquid dish soap. Dry the parts thoroughly after cleaning and reassemble the burners (see “Cleaning and care”).

Turning on the cooktop for the first time

The metal components have a protective coating. When the cooktop is used for the first time, this causes a smell and possibly also vapor.

The smell and any vapors do not indicate a faulty connection or a defective appliance and are not harmful to your health.

- Select cookware that fits the size of the burner:
Large diameter = large burner
Small diameter = small burner
- A wok burner is particularly suitable for wok pans. Do not allow the base of the wok pan to come into contact with the burner. There must be a gap of at least 3/8" (1 cm) between the burner and the base of the pan.
- Unlike cookware that is used on an electric cooktop, the bottom of cookware used on a gas cooktop does not have to be flat to deliver effective cooking performance.
- When purchasing cookware, keep in mind that the diameter indicated is typically the top diameter, not the base diameter.
- All heat-resistant cookware is suitable for use.
- Cookware with a thick base is preferable, as it distributes heat more evenly. Cookware with a thin base may cause food to overheat in certain spots. To avoid this, stir the food frequently.
- Always place the cookware on the grates supplied. Do not place cookware directly on the burner.
- Position the cookware on the grates so that it cannot tip. Even when cookware is positioned correctly, there is always a possibility of a slight tilt.



- Do not use cookware with bases with pronounced edges.

Wok ring

- Use the wok ring supplied to give additional stability to cookware, especially to woks with a rounded base.
- Place the wok ring on the pan support so that it sits securely in position and cannot move (see diagram).

Energy saving tips

- Whenever possible, keep pots and pans covered while cooking. Doing so will prevent unnecessary heat loss.
- Wide, shallow cookware heats up faster and is therefore preferable to tall, narrow cookware.
- Cook with as little water as possible.
- Reduce the power setting once the water has come to a boil or the oil/fat is hot enough for frying.
- Use a pressure cooker to reduce the cooking time.



Fire hazard due to overheated food.

Unattended food can overheat and ignite.

Do not leave the cooktop unattended while it is being used.

Turning the appliance on

- Press in the knob and turn it counterclockwise to the large flame symbol. The ignitor “clicks” and ignites the gas.

When a knob is activated, a spark is automatically produced on all burners. This is normal and does not indicate a fault.

- When a flame is visible, keep the knob pressed in for 5–10 seconds, and then let it go.
- If the burner does not ignite, turn the knob to • burner off. Ventilate the room or wait for at least 1 minute before trying again. When making another ignition attempt, it may be necessary to press in the knob for longer.
- If the burner does not ignite the second time, turn the knob back to • burner off and see “Frequently asked questions”.

Switching on during a power outage

In case of a power outage, the flame can be ignited manually.

- Press in the relevant control knob and turn it counterclockwise to the large flame symbol.
- Hold the control knob pressed down and light the gas at the burner with a match.
- Keep the control knob pressed down for an additional 5–10 seconds and then release it.

Operation

Adjusting the flame

The burners can be variably adjusted between the lowest and highest flame settings.

Because the edges of the flame are much hotter than its center, the flame tips should stay beneath the bottom of the cookware. Flame tips which extend beyond the sides of the cookware emit unnecessary heat into the room and can also damage cookware handles, which increases the risk of injury.

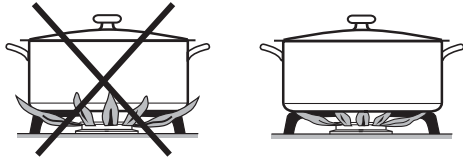

- Adjust the flame so that it never extends up the sides of the cookware.

Visual features of gas flames

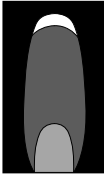
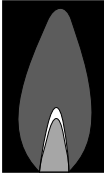
	Yellow flames Call Customer Service.
	Yellow tips on the outer cone Normal for LP gas
	Pale blue flames possibly with yellow tips on the inner cone Normal for natural gas

Switching off

- Turn the knob clockwise to • burner off.

This stops the flow of gas and the flame goes out.

Ignition safety

Your cooktop is equipped with an ignition safety control. If a gas flame is extinguished, e.g., by food boiling over or by a draft, the gas supply is switched off. This prevents the release of gas. If you turn the knob to • burner off, the burner is ready for use again.

The ignition safety control operates independently from the power supply. This means that it will still work if the cooktop is used during a power outage.

Cleaning and care

 Danger of burning due to hot surfaces.

The cooktop surface, grates, and burners will be hot after use.

Allow the cooktop to cool down before cleaning it.

 Risk of damage due to moisture ingress.

The steam from a steam cleaning appliance could reach electrical components and cause a short circuit.

Do not use a steam cleaner to clean the cooktop.

All surfaces could be discolored or damaged if unsuitable cleaning agents are used. All surfaces are susceptible to scratching.

Remove all cleaning agent residues immediately.

Do not clean with any abrasive or sharp pointed objects.

Food boiling over can cause discoloration of the burner components.

Remove any soiling and salt and sugar splashes immediately.

Pressing the knob generates a spark on the ignitor. Do not press the knob while you are cleaning or touching the cooktop or a burner in the vicinity of an ignitor.

Unsuitable cleaning agents

To avoid damaging the surfaces of the appliance, do not use:

- cleaning agents containing soda, alkalines, ammonia, acids, or chlorides,
- cleaning agents containing lime scale remover
- stain or rust removers
- abrasive cleaning agents, such as scouring powder, scouring liquid, or pumice stones
- cleaning agents containing solvents
- dishwasher cleaner
- grill and oven sprays
- glass cleaners
- hard, abrasive brushes or sponges (e.g., pot scourers), or sponges which have been previously used and still contain abrasive cleaning agents
- eraser sponges

- The entire cooktop should be cleaned after each use.
- Soften any stubborn soiling beforehand.
- Dry the cooktop after using water to clean it. This helps prevent lime deposits.

Cleaning the stainless-steel cooktop

 Risk of damage caused by pointed objects.
The seal between the cooktop and the countertop could be damaged. Do not use pointed objects for cleaning.

 Damage due to soiling.
Soiling, particularly salty food or liquid and olive oil, can cause damage if left on the printed surfaces for a long time.
Remove such soiling immediately.

 Damage due to incorrect cleaning.
Stainless-steel cleaners rub off the printed symbols.
Do not use stainless-steel cleaners on printed symbols.

- Clean the stainless-steel cooktop with a solution of warm water and a little liquid dish soap applied with a soft sponge. Soften any stubborn soiling beforehand. If necessary, the rough side of a kitchen sponge can be used.
- Finally, dry with a clean soft cloth.

Cleaning and care

Cleaning the grates

- Remove the grates.
- Clean the grates in a dishwasher or with a solution of warm water and a little liquid dish soap applied with a soft sponge. Soften any stubborn soiling beforehand.
- Dry the the grates thoroughly with a clean cloth.

Cleaning the knobs

The knobs are not dishwasher-safe. The knobs should only be cleaned by hand.

The knobs may become discolored if they are not cleaned regularly. Clean the knobs after each use.

- Clean the knobs with a soft sponge, warm water, and a small amount of liquid dish soap.

Cleaning the burner

Do not clean any parts of the burner in a dishwasher.

The surface of the burner cap will become more matte with time. This is quite normal and does not indicate damage to the burner cap.

- The burner should be dismantled and then cleaned only by hand using a solution of warm water and a small amount of liquid dish soap applied with a soft sponge.
- Clean any soiling from the flame openings.

 Risk of explosion.

Blocked flame openings can cause a dangerous build-up of gas in the base of the cooktop which could ignite and cause an explosion. This can lead to damage to the appliance and injury. Ensure the flame openings are kept clean at all times.

- Parts of the burner that cannot be removed should be wiped clean with a damp cloth only.
- The ignitor and thermocouple should be very carefully wiped clean using a well wrung out cloth.

Do not let the ignitor get wet. If it gets wet, it will not spark.

- Finally dry everything thoroughly with a clean cloth. Make sure that the flame openings are completely dry.

Cleaning and care

Assembling the burner

Assembling the economy, normal, and power burners

Assembling the economy, normal and power burners

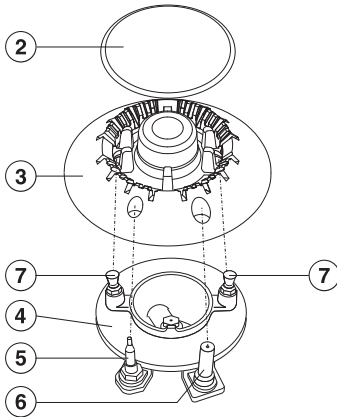

- Place the burner head ③ onto the burner base ④ so that the thermocouple ⑤, the ignitor ⑥ and the retaining pins ⑦ fit into their respective holes in the burner head.
- Position the burner cap ② onto the burner head ③ so that the retaining pins fit into their respective recesses. Gently twist the burner cap clockwise or anti-clockwise until it locks into position. When correctly positioned, the burner cap will not slide about.

Ensure that all parts of the burner are reassembled in the correct order.

Assembling the wok burner

Wok burner

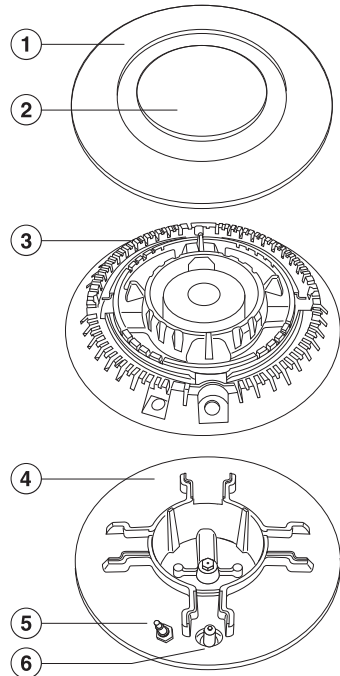

Checking burning properties

- Ignite all burners to check that they are operating correctly:
 - The flame must not go out on the lowest setting, or when the knob is turned quickly from the highest to the lowest setting.
 - On the highest setting, the flame must have a distinctive and visible core.

Frequently asked questions

Many malfunctions and faults that can occur in daily operation can be easily remedied. You can save time and money in many cases, as you do not need to contact Miele Customer Service.

Information to help you rectify faults yourself can be found at www.miele.com/service.

The following tables are designed to help you to find the cause of a malfunction or fault and resolve it.

Problem	Possible cause and solution
The burners do not ignite when the cooktop is being used for the first time or after it has been out of use for a longer period.	There may be air in the gas line. ■ Try to light the burner again, making several attempts if necessary.
The burner does not light after several attempts.	There is a technical fault. ■ Turn all the knobs clockwise to • burner off and disconnect cooktop from the power supply for a few seconds.
	The burner is not properly assembled. ■ Assemble the burner correctly.
	The gas shut-off valve is closed. ■ Open the gas shut-off valve.
	The burner is wet and/or dirty. ■ Clean and dry the burner.
	The flame holes are clogged and/or wet. ■ Clean and dry the flame holes.
The gas flame goes out after being lit.	The flames do not touch the thermocouple and the burner does not get hot enough: The burner parts are not positioned correctly. ■ Assemble the burner components correctly.
	The ignition safety device is dirty. ■ Remove any dirt or grime.
The shape/color of the gas flame changes.	The burner parts are not in the proper position. ■ Position the burner parts correctly.
	The burner cap itself or the holes in the burner cap are dirty. ■ Remove any dirt or grime.

Frequently asked questions

Problem	Possible cause and solution
The gas flame goes out during use.	The burner parts are not in the proper position. ■ Assemble the burner components correctly.
The ignitor does not function properly.	The circuit breaker in the building's wiring system was tripped. ■ If necessary, contact a qualified service technician or Technical Service for assistance.
	There is food residue stuck between the ignitor and the burner cap. The thermocouple is dirty. ■ Remove any soiling (See "Cleaning and care").

Optional accessories

Miele offers a range of useful accessories, as well as cleaning and conditioning products for your appliance.

These products can be easily ordered from the Miele webshop.

Ceramic and stainless steel cleaner 250 mL

Removes heavy soiling, lime scale, and aluminum residue.

Contact in the event of a fault

In the event of a fault which you cannot remedy yourself, please contact your Miele dealer or Miele Customer Service.

You can book a Miele Service Call online at www.miele.com/service.

Contact information for Miele Customer Service can be found at the end of this document.

Please quote the model identifier and serial number of your appliance (SN) when contacting Miele Customer Service. Both pieces of information can be found on the data plate.

Appliance warranty and product registration

You can register your product and/or view the manufacturer's warranty terms and conditions for Miele appliances and vacuum cleaners at www.mieleusa.com.

Installation

IMPORTANT SAFETY INSTRUCTIONS - INSTALLATION



Risk of damage caused by incorrect installation.

Incorrect installation can damage the cooktop.

The cooktop must only be installed by a qualified specialist.



Damage from falling objects.

Take care not to damage the cooktop when installing cabinetry or a ventilation hood above it.

Install the cabinetry and ventilation hood before installing the cooktop.

- ▶ The room in which the cooktop is installed must conform to all relevant local and national building regulations and safety regulations.
- ▶ The countertop must be heat-resistant (up to 212°F / 100°C), so that it does not become deformed or the veneer detached. The wall strips must be heat-resistant as well.
- ▶ The cooktop must not be installed above refrigerators/freezers, dishwashers, or washer/dryers.
- ▶ A gas cooktop must not be installed directly next to a deep fat fryer as the gas flames could ignite the fat in the fryer. It is essential to maintain a distance of at least 12" (300 mm) between these two appliances.
- ▶ When installing the cooktop, make sure that the gas pipe and power cord cannot come into contact with hot appliance parts.
- ▶ The power cord and any flexible gas connection pipes must be installed in such a way so that they do not come into contact with any moving kitchen parts (e.g. a drawer), and cannot become trapped.
- ▶ Observe carefully the safety clearances listed on the following pages.

Safety distances

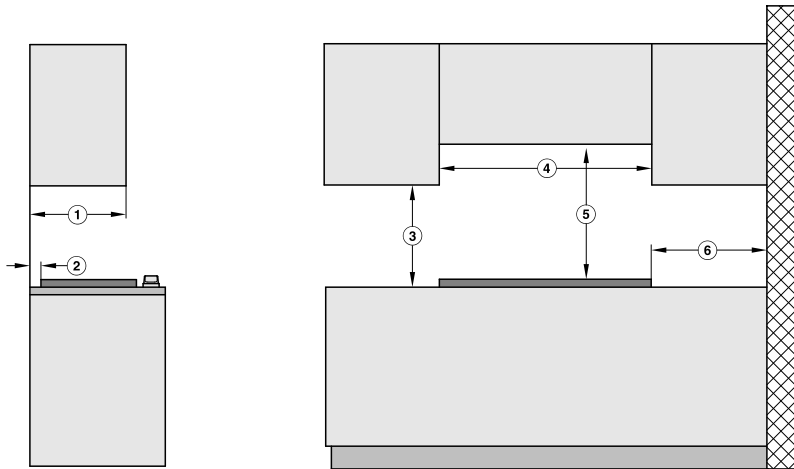

Position	Dimension	Description
①	13" (330 mm)	Maximum depth of wall cabinet
②	2" (50 mm)	Minimum distance to back wall
③	18" (457 mm)	Minimum safety distance to bottom edge of adjacent wall cabinet
④	≥ cooktop width	See "Installation – Installation dimensions"
⑤	30" (762 mm) ¹	Minimum safety distance between the top of the cooktop surface and the bottom of an unprotected combustible surface.
⑥	4" (100 mm)	Minimum distance to a side wall

¹ The minimum safety distance given by the hood manufacturer must be maintained between the cooktop and the hood above it. See the installation instructions of the hood for these safety measurements.

If there is more than one appliance beneath a hood (e.g., gas cooktop and electric cooktop), and they have different minimum safety distances always observe the greater distance.

Installation

Installation notes

Seal between cooktop and countertop

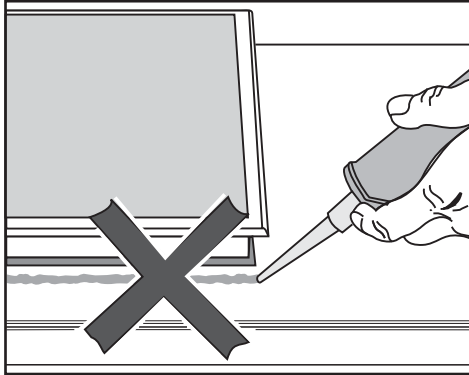

 Damage caused by incorrect installation.

Using sealant under the cooktop could result in damage to the cooktop and the countertop if the cooktop ever needs to be removed for servicing.

Do not use sealant between the cooktop and the countertop.

The sealing strip under the edge of the cooktop provides a sufficient seal for the countertop.

Sealing strip

Dismantling the cooktop for service purposes may damage the sealing strip underneath the edge of the cooktop.

Always replace the sealing strip before reinstalling the cooktop.

Tiled countertop

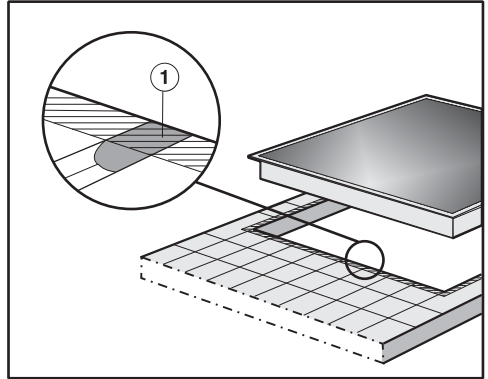

Grout lines ① and the shaded area under the cooktop frame must be smooth and even. If they are not, the cooktop will not sit flush with the countertop and the sealing strip underneath the cooktop will not provide a good seal between the cooktop and the countertop.

Installation dimensions

All dimensions in this instruction booklet are given in mm and inches.

KM 2012

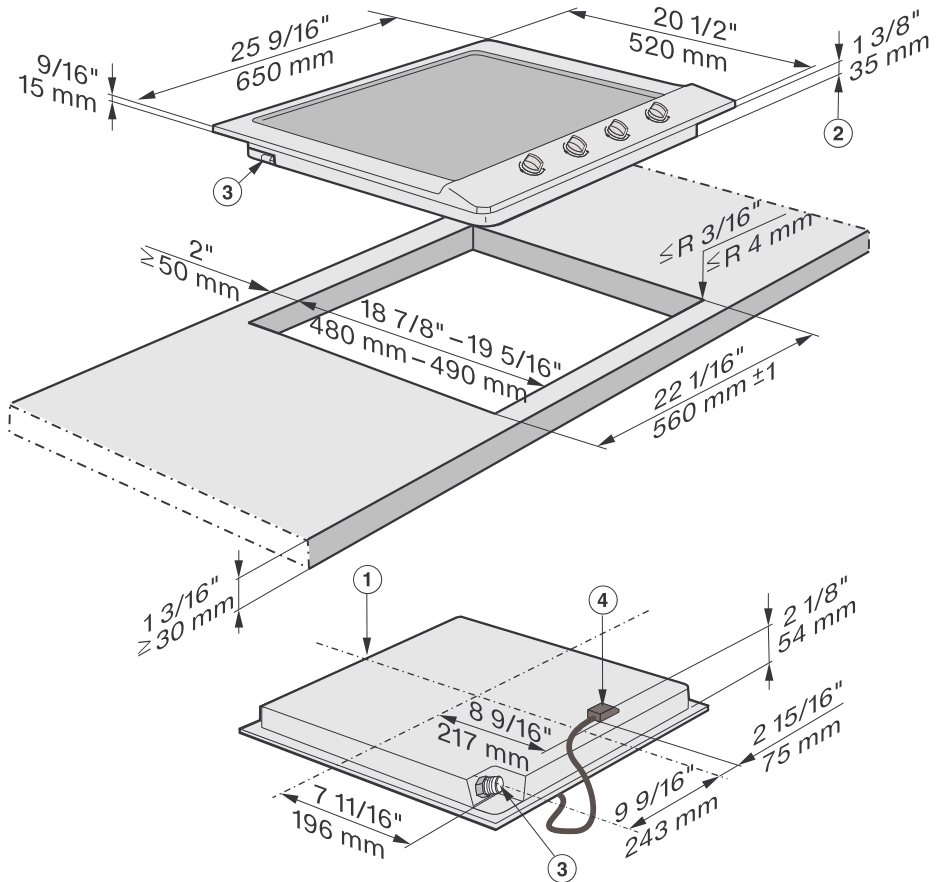

- ① Front
- ② Casing depth
- ③ Gas connection $R \frac{1}{2}''$ NPT
- ④ Electrical supply connection box with power cord, L = 4' (1,200 mm)
- ⑤ Front
- ⑥ Cooktop height

- ⑤ Front
- ⑥ Cooktop height
- ⑦ Gas connection R 1/2" - ISO 7-1 (DIN EN 10226)
- ⑧ Electrical supply connection box with power cord
Power cord L = 4' (1,200 mm)

Installation

Installation

Preparing the countertop

- Create the countertop cut-out. Remember to maintain the minimum safety distances (see “Installation” – “Safety distances”).
- Seal any cut surfaces on **wooden countertops** with a special varnish, silicone rubber, or resin to prevent the wood from swelling as a result of moisture. The sealant must be temperature-resistant.

Ensure that the sealant does not get on the top surface of the countertop.

The sealing strip ensures that the cooktop will sit securely in the cut-out without slipping. Any gap between the frame and countertop will become smaller over time.

Installing the cooktop

- Attach the sealing strip provided underneath the edge of the cooktop.
- Feed the cooktop power cord down through the countertop cut-out.
- Place the cooktop in the center of the cut-out. When doing this, make sure that the seal of the appliance sits flush with the countertop on all sides. This is important to ensure an effective seal all round.

If during installation the seal around the frame does not sit flush with the countertop in the corners, the corner radius ($\leq R4$) can be carefully filed down to fit.

Do not use any additional sealant (e.g., silicone) on the cooktop.

- Connect the cooktop to the power supply (see “Installation – Electrical connection”).
- Connect the cooktop to the gas supply (see “Installation – Gas connection”).

Securing the cooktop

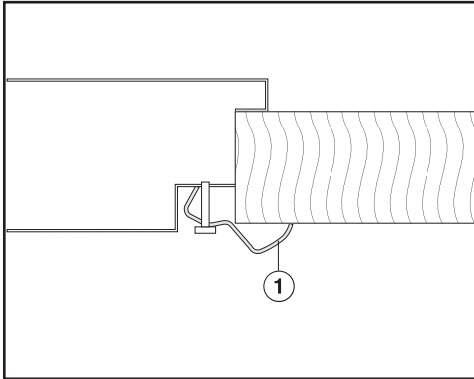

- Secure the cooktop using the brackets ① supplied.

Checking for proper function

- After installing the appliance, ignite all burners to check that they are operating correctly:
 - The flame must not go out on the lowest setting, or when the knob is turned quickly from the highest to the lowest setting.
 - On the highest setting, the flame must have a distinctive and visible core.

Installation

Gas connection

 Connection to the gas supply may only be performed by a duly authorized technician. This technician is responsible for proper function at the installation site.

In Massachusetts, the gas connection may be performed only by a certified gas installer.

The appliance must be connected with its own shut-off valve. The shut-off valve must be accessible and visible, after the opening of a cabinet door, if necessary.

The gas connection can be to natural gas or propane gas according to the model.

Ask your gas company what kind of gas is used and compare it with the specifications on the data plate.

The appliance is not connected to an exhaust vent.

During the setup and connection of the appliance, observe the applicable installation conditions, especially suitable ventilation measures.

Arrange the gas connections in such a way that they are not heated and damaged by the operation of the appliance.

In particular, make sure that the gas hose lines and connection fittings on the appliance do not come into contact with hot exhaust gases

The gas hose and power cord could be damaged by hot spots on the appliance.

Make sure that the gas hose and power cord do not come into contact with hot spots on the appliance.

Flexible connection lines can be damaged by incorrect routing.

Attach flexible connecting lines in such a way so that they do not come into contact with any moving kitchen parts (e.g., a drawer) and are not exposed to mechanical stress.

Disconnect the appliance and the shut-off valve from the gas supply before performing a gas pressure test at a pressure of more than ½ psi (3.5 kPa). Close the shut-off valve of the gas supply before performing a gas pressure test at a pressure of less than or equal to ½ psi (3.5 kPa).

Incorrectly sealed gas lines can lead to a gas leak and thus to an explosion.

Seal all gas lines with a suitable thread sealant.

Leak testing of the appliance shall be conducted according to the manufacturer's instructions.

The gas connection must be made in accordance with local codes or, in the absence of local codes, with:

National Fuel Gas Code
ANSI Z 223.1 / NFPA No. 54 for the United States or the current Natural Gas and Propane Installation Code, CSA B149.I. for Canada.

The gas pressure may not under-shoot or exceed certain values. Make sure that the maximum gas pressure upstream of the gas pressure controller does not amount to more than ½ psi (3.5 kPA) for natural and propane gas. Make sure that the minimum gas supply pressure amounts to 6" w.c. for natural gas and 11" w.c. for propane gas.

The gas connection of the appliance is designed for natural gas or propane gas according to the ordered model (see adhesive label on the appliance).

If the appliance is not equipped with the correct connection for the gas type in your household, contact your Miele dealer.

After conversion to a different type of gas, save the jets removed from the cooktop for future use.

Installation

Gas pressure regulator

The included pressure regulator corresponds with the gas type of the appliance. Verify before installing.

The adjusted pressure is:
Natural gas 4" w.c.
LP gas 10" w.c.

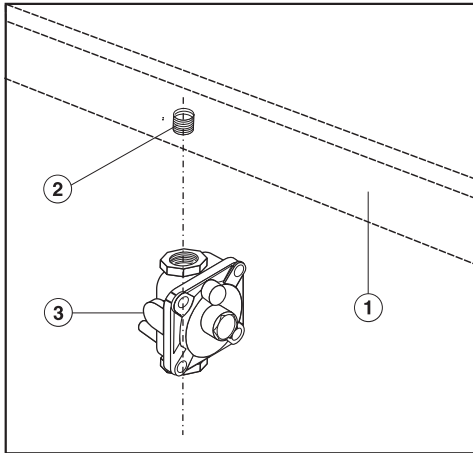

- ① Appliance
- ② 1/2" NPT gas connection
- ③ Regulator

The regulator must be installed as shown in the diagram when you connect the Miele appliance to your gas connection. The regulator has been adapted by Miele to meet all statutory safety requirements. The regulator must be easily accessible after the appliance has been installed.

A flexible steel hose approved by the AGA or CGA can be used between the gas connection and the regulator. This flexible hose enables the appliance to be lifted out of the cut-out for maintenance or repair work. Check to make sure that no drawers, doors, or similar come into contact with this flexible hose.

Gas leak due to unsuitable regulator. Only use the regulator supplied by Miele.

If you are in any doubt, contact Miele Customer Service.

Leakage test

Leak testing of the appliance shall be conducted according to the manufacturer's instructions.

- After connecting the appliance check all fittings for gas leaks e.g. with soapy water.

Burner ratings

Nominal ratings KM 2012

Burner	Gasart	kW	BTU/hr
Economy burner	Natural gas NG	1.11	3,800
	Liquid propane LP	1.11	3,800
Normal burner	Natural gas NG	1.61	5,500
	Liquid propane LP	1.61	5,500
Wok	Natural gas NG	3.31	11,300
	Liquid propane LP	3.31	11,300
Total	Natural gas NG	7.65	26,100
	Liquid propane LP	7.65	26,100

Nominal ratings KM 2032

Burner	Gasart	kW	BTU/hr
Economy burner	Natural gas NG	1.11	3,800
	Liquid propane LP	1.11	3,800
Normal burner	Natural gas NG	1.61	5,500
	Liquid propane LP	1.61	5,500
Power burner	Natural gas NG	2.52	8,600
	Liquid propane LP	2.52	9,500
Wok	Natural gas NG	3.31	11,300
	Liquid propane LP	3.31	11,300
Total	Natural gas NG	10.17	34,700
	Liquid propane LP	10.43	35,600

Installation

Electrical connection

ATTENTION:

During installation, maintenance and repair work, the appliance must be disconnected from the electricity supply. It is only completely isolated from the electricity supply if the plug fuses have been fully unscrewed (where applicable), the main circuit breaker has been tripped or the power cable has been unplugged from the wall outlet.

Do not cut off the plug on the power cord. If the plug does not fit in the outlet, have an electrician install an appropriate outlet.

The socket must be easily accessible after the appliance has been installed.

Work by unqualified persons can cause considerable danger to users. Miele cannot be held liable for any damage arising as a result of such work.

Installation, repair and maintenance work should only be performed by a Miele authorized service technician.

To avoid damaging the appliance, the information (voltage and frequency) on the data plate must correspond to the building's power supply.

Compare these informations before connecting the appliance. When in doubt, consult a qualified electrician.

The plug must be inserted into a suitable outlet that has been installed and grounded in compliance with all applicable local regulations.

To guarantee the electrical safety of this appliance, continuity must exist between the appliance and an effective grounding system. It is imperative that this basic safety requirement be met. If there is any doubt, have the electrical system of the house checked by a qualified electrician.

Installation, repair and maintenance work should only be performed by a Miele-authorized qualified electrician in compliance with local regulations and the ANSI National Electrical Code / NFPA 70 in the United States or the Canadian Electric Code, CSA C22.1-02. in Canada.

Power cord and plug

The appliance is equipped with a flexible power cord and a 3-prong grounding plug for your protection against shock hazard. The plug must be inserted into a properly grounded outlet.

- **Do not** cut or remove the grounding prong from this plug.

Total output

See data plate

Connection data

The connection data is given on the data plate. Please ensure these match the household electrical supply.

- Important – Save these instructions for the local electrical inspector's use.

Please have the model and serial number of your appliance available when contacting Customer Service.

U.S.A.

Miele, Inc.

National Headquarters

9 Independence Way
Princeton, NJ 08540
www.mieleusa.com

Customer Support

Phone: 888-99-MIELE (64353)
info@mieleusa.com

International Headquarters

Miele & Cie. KG
Carl-Miele-Straße 29
33332 Gütersloh
Germany

Canada

Importer
Miele Limited

Headquarters and Miele Centre

161 Four Valley Drive
Vaughan, ON L4K 4V8
www.miele.ca

Customer Care Centre

Phone: 1-800-565-6435
905-532-2272
contact@miele-support.ca

KM 2012, KM 2032

en-US, CA

M.-Nr. 10 810 470 / 05