



Installation plan Washer-dryer stack PDW 909 GB





Always read the operating instructions before setting up, installing and commissioning the machine. This prevents both personal injury and damage to the machine.

en-GB

Contents

Installation notes	3
Explanation of the safety notes and warnings on the machine	3
Installation requirements	3
Transportation and site access.....	3
General operating conditions	3
Installation.....	4
Levelling the machine	5
Electrical connection	5
Plumbing.....	6
Cold water connection.....	6
Hot water connection	7
Drain pump (depending on model)	7
Dispenser connection.....	8
Supply air and exhaust air management.....	9
Ventilation	9
Exhaust air management	9
Calculating the total ducting length	10
Exhaust air management with plug-in pipes.....	11
Exhaust air management with flexible aluminium hose.....	12
Shared exhaust air ducts	12
Optional accessories	14
Washing machine accessories	14
Tumble dryer accessories.....	15
Installation	16
Standard	16
Installation	18
Standard	18
Floor anchoring.....	19
Technical data	20
Voltage versions and electrical data	20
Plumbing.....	20
Cold water connection.....	20
Hot water connection	20
Drainage (DP).....	20
Air intake	20
Vented system	21
Equipotential bonding.....	21
Installation dimensions	21
Transport data, weight and floor load.....	21
Emissions data.....	21

Explanation of the safety notes and warnings on the machine

	Read the operating instructions
	Warning, hot surfaces
	Warning, voltage up to 1000 volts
	Protective earthing
	Equipotential bonding

Installation requirements

The washer-dryer stack may only be commissioned by the Customer Service Department or by a Miele specialist dealer.

The washing machine or tumble dryer must not be operated as individual machines.

- ▶ Suitable personal protective equipment must be worn during installation or maintenance.
- ▶ The washer-dryer stack must be installed in accordance with applicable regulations and standards. Local energy supplier and water authority regulations must also be observed.
- ▶ This washer-dryer stack must only be operated in a room that has sufficient ventilation and is frost-free.

This washer-dryer stack should not be installed or operated in any area where there is a risk of explosion.

Transportation and site access

The machine must not be moved without the transit bars in place. Keep the transit bars in a safe place. They must be refitted if the machine is to be moved again (e.g. when relocating the machine).

General operating conditions

This washer-dryer stack is intended only for use in a commercial environment and must only be operated indoors.

- Ambient temperature: 0-40 °C
- Relative humidity: non-condensing
- Maximum height above sea level of location site: 2000 m

Depending on the nature of the installation site, sound emissions and vibration may occur.

Tip: Have the installation site inspected and seek the advice of a specialist in instances where increased noise may cause a nuisance.

Installation notes

Installation

Transport the washing machine and the dryer in the washer-dryer stack to the installation site one at a time using a suitable pallet truck, and remove the transport packaging.

The washer-dryer stack must be installed by the Miele Customer Service Department or by an authorised dealer. Please observe the information on the installation plan.

This washer-dryer stack is only intended for items of laundry that have not been proofed with dangerous or inflammable substances.

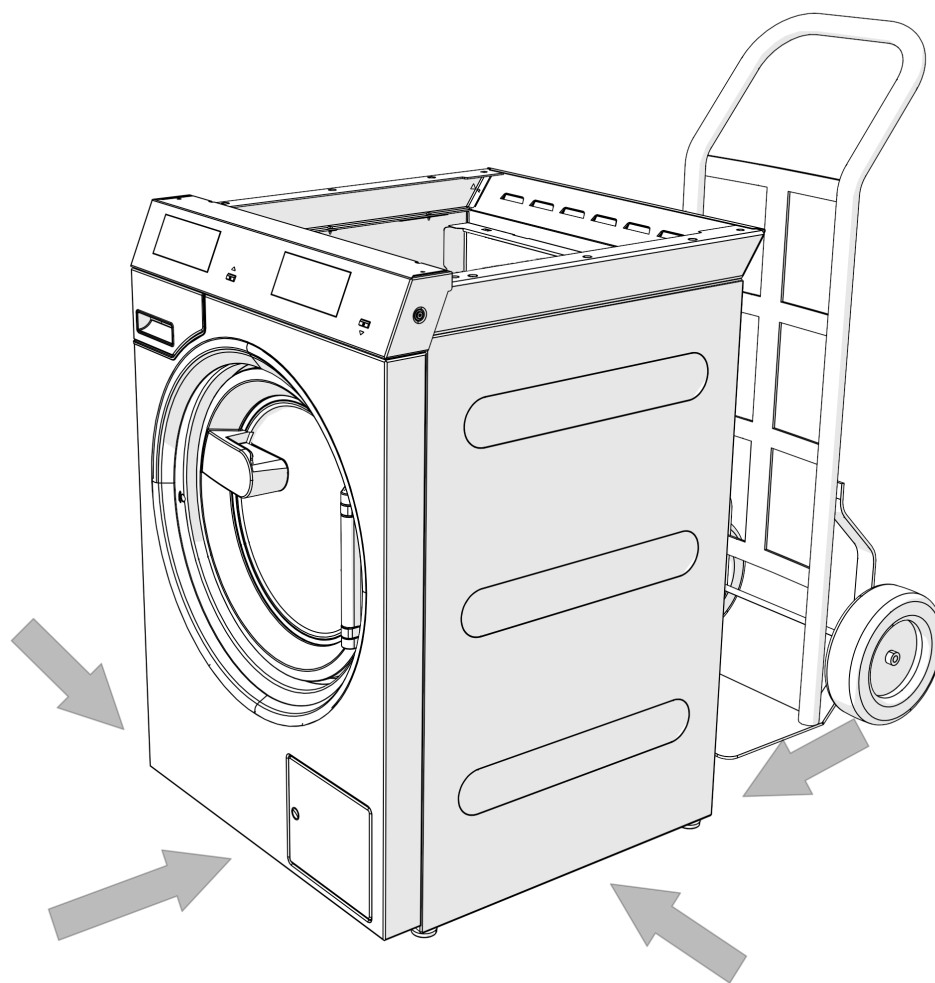

⚠ During transportation of the machines, ensure their stability.

⚠ Do not pick them up by the drum door.

The washer-dryer stack must be set up on a completely level, horizontal and firm surface with the minimum stated floor load capacity (see “Technical data”).

Tip: A concrete floor is the most suitable installation surface. It is far less prone to vibration during the spin cycle than wooden floorboards or a carpeted surface.

The floor load created by the washer-dryer stack is the load exerted by the area of the machine in contact with and transferred to the installation surface.

The washer-dryer stack requires a gap of at least 300 mm on each side to allow for movement during operation. Please ensure a minimum distance of 400 mm is maintained between the rear of the machine and the rear wall.

The washer-dryer stack must not be installed on a carpeted floor.

The feet of the washer-dryer stack must be secured to the fastening points on the floor using the fittings supplied.

The fittings included are for bolting the washer-dryer stack to a concrete floor. If other floor types are present at the installation site, the fastening material must be ordered by the customer.

Levelling the machine

- Align the washing machine vertically and horizontally using the adjustable feet and a spirit level.

The washing machine must stand evenly and horizontally on all four feet to ensure trouble-free and energy-efficient operation. Otherwise the water and energy consumption increases and the washing machine might move around.

- After aligning the machine, tighten the lock nuts by turning them in a counterclockwise direction with a spanner. This will prevent the feet from adjusting themselves.

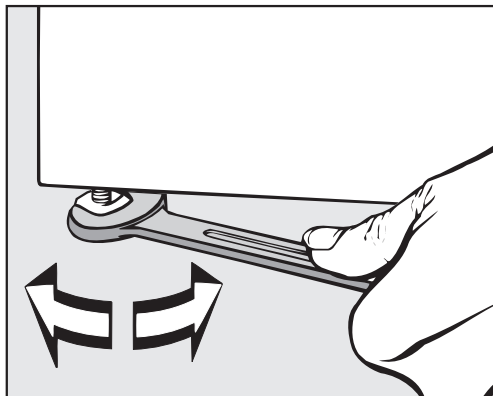

Electrical connection

The electrical connection must only be carried out by a qualified electrician who must ensure that all electrical work is carried out in accordance with applicable electrical regulations and standards (BS 7671 in the UK).

- This washer-dryer stack must be connected to an electrical mains supply that complies with local and national regulations. Please also observe your insurance and energy supplier's regulations as well as any health and safety at work regulations.

Installation notes

► The required voltage, power rating and fuse rating can be found on the data plate on the washer-dryer stack. Before connecting the washer-dryer stack to the power supply, please ensure that the mains supply voltage complies with the values given on the data plate.

Connection to a supply voltage other than the one quoted on the data plate can lead to functional faults and damage to the washer-dryer stack.

If more than one voltage is quoted on the data plate, the washer-dryer stack can be converted for connection to the voltages stated by the Miele Customer Service Department.

► Conversion to a different voltage must only be carried out by the Miele Customer Service Department or by an authorised dealer. The wiring instructions given on the wiring diagram must be followed. Depending on the models, the machines are delivered with a mains connection cable with/without a plug. References to cable cross-sections in the technical data refer only to the required mains connection cable. Please consult relevant local and national regulations when calculating any other wire gauges.

Tip: It is recommended to connect the washer-dryer stack to the power supply via a plug and socket so that it is easier to conduct electrical safety checks (e.g. during maintenance).

It is advisable to connect the product via a suitably rated plug and socket in accordance with IEC-60309, otherwise for a hardwired connection an all pole means of isolation must be installed at the site.

An isolation device is a switch which ensures a contact opening of more than 3 mm. These include circuit breakers, fuses and contactors (IEC/EN 60947).

The wall socket or isolator must remain accessible at all times once the machines have been installed. However, it is always recommended to make electrical connections via a suitable plug and socket so that electrical safety checks, e.g. during repair or maintenance work, can be carried out easily.

If the mains supply cannot be permanently disconnected, the isolator switch (including plug and socket) must be safeguarded against being switched on either unintentionally or without authorisation.

► If it is necessary to install a residual current device (RCD) in accordance with local regulations, a residual current device type B (sensitive to universal current) must be used.

An existing type A residual current device (RCD) must be exchanged for a type B RCD.

► If local and national installation specifications require equipotential bonding, good galvanic contact must be guaranteed. Equipotential bonding must have an earth current rating > 10 mA.

Plumbing

Cold water connection

For the cold water connection one stopcock each with a $\frac{3}{4}$ " screw thread is required.

If a water connection is not available, only a qualified installer may connect the washing machine to the mains water supply.

The water inlet hose for cold water is not suitable for connection to a hot water supply.

In the event that hot water is not available on site, a cold water supply must be used for the hot water connection.

The required amount of hot water should be added to the cold water volume.

Alternatively, the hot water connection should be blocked using the blind stopper supplied with the machine and the machine controls should be set to cold water intake by the service technician.

Hot water connection

The same connection requirements as for cold water also apply to hot water up to 60 °C.

A suitable connection hose with a threaded union is supplied with the machine.

The machine with hot water connection also requires a cold water connection.

In the event that hot water is not available on site the hot water connection should be blocked using the blind stopper and the machine controls should be set to cold water intake.

Alternatively a cold water supply can be used for the hot water connection.

The required amount of hot water should be added to the cold water volume.

Drain pump (depending on model)

In machines with drain pump, the suds are drained through a drain pump with a delivery head of max. 1 m.

The drain hose must be installed free of kinks for the suds to drain freely.

There are the following options for draining the machine:

- Drain hose connected to a plastic drain pipe with a rubber sleeve (there is no need to use a siphon)
- Drain hose connected securely to a sink with a plastic nipple

If required, the hose can be extended to a length of up to 5 m. The corresponding accessories are available from the Miele Customer Service Department or your Miele dealer.

For a drain height of more than 1 m, a replacement drain pump for a delivery head of max. 1.8 m is available from the Miele Customer Service Department or from your Miele dealer.

Water connection

For compliance to The Water Supply (Water Fittings) Regulations 1999, please fit the double check valves included in the scope of supply to the on-site water supply for every water inlet hose used. The double check valves prevent water from the inlet hoses flowing back into the on-site drinking supply. Non-return valves are included in the scope of supply.

Installation notes

The flow pressure must be a minimum of 100 kPa and must not exceed 1000 kPa. If the flow pressure is higher than 1000 kPa, a pressure reducing valve must be used. The machine must be connected to the water supply using the inlet hoses included in the scope of supply.



The connection points are subject to water supply pressure. Turn on the stopcock slowly and check for leaks. Correct the position of the seal and screw thread if appropriate.

Dispenser connection

The machine is equipped with an interface for external dispenser systems. Adapters for pre-mixed suds or liquid detergent from external dispenser systems for up to 6 connections should be obtained from the Miele Customer Service Department and connected.

A separate Connector Box is required for controlling the dispensing pumps electrically. This must be installed by your Miele dealer or the Miele Customer Service Department. It is particularly important to follow the manufacturer's instructions when using a combination of cleaning agents and special application products.

Supply air and exhaust air management

Ventilation

The air required for drying is taken from the room where the tumble dryer is installed.

Ensure sufficient room ventilation, e.g. by means of ventilation openings that cannot be closed in the exterior wall.

- It must not be possible to seal off ventilation openings.
- The room ventilation is only working properly if no low pressure occurs. Avoid low pressure, e.g. by means of ventilation openings in the exterior wall.
- For each tumble dryer, there must be a cross section of 339 cm² per ventilation opening.

The tumble dryer draws in air at the back. Therefore, there must be a sufficiently large gap between the back of the machine and the wall.

This would otherwise hinder a sufficient flow of air as well as the operational performance of the tumble dryer.

Observe the necessary spacing between the machine and the wall.

Do not reduce the gap between the bottom of the tumble dryer and the floor (e.g. plinth facings, deep pile carpet).

Exhaust air management

The tumble dryer must only be operated if the humid exhaust air generated during drying is led outside through an installed vent ducting.

Exceptions regarding the design of the exhaust air management system must be designed in accordance with the applicable local building regulations. Seek approval from the relevant building inspector.

The tumble dryer exhaust should be finished with a suitable terminal, we recommend a 90° downward facing elbow.

- While installing the ducting, keep the tumble dryer disconnected from the mains power supply.
- Make sure that the duct connections are fully sealed.
- Only use heat-resistant materials with a temperature resistance of at least 80 °C.
- Condensation will form in the exhaust air management system. A condensate drain must therefore be placed at the lowest point in the system.

The opening of the vent ducting (e.g. a wall pipe) must be arranged in such a way that the humid exhaust air:

- Does not flow back into the room where the tumble dryer is installed.
- Does not cause damage or unacceptable disturbance.

Installation notes

The air required for drying is taken from the room where the dryer is installed. You must therefore ensure that the room is sufficiently ventilated. Otherwise, there is a risk of suffocation due to exhaust gases being sucked back from other technical systems or fuel-burning installations, and the drying time will be much longer.

The following should be avoided:

- Long vent ducting
- Too many tight bends or elbows

This will help to stop a reduced dryer performance and excessive time and energy requirements.

Use:

- For the vent ducting: exhaust hose* or a plastic waste water pipe (e.g. HT piping systems) with a minimum diameter of 100 mm.
- *optional accessories

Calculating the total ducting length

The friction of the vent ducting with its bends and various components provides resistance to the flow of air. This friction resistance is expressed as a relative pipe length. The **relative pipe length** indicates how much greater the resistance of a bend is, for example, when compared to 1 metre of a straight plastic waste water pipe (table I).

Adding together the relative pipe lengths for all of the components gives the **total ducting length**. The total ducting length expresses the resistance of the entire exhaust air system.

As a larger **duct diameter** has a lower flow resistance, a longer duct requires a greater duct diameter (table II).

Procedure

1. Measure the length needed for the straight sections of ducting. Multiply this value by the corresponding relative pipe length from **table I**.
2. Calculate the number of bends and components needed. Use **Table I** to help you add together their relative pipe lengths.
3. Add together all of the relative pipe lengths calculated above in order to calculate the total ducting length.
4. Refer to **Table II** for the pipe diameter needed for the total ducting length.

Table I	
Components	Relative pipe length
Exhaust air hose (flexible aluminium)* / pipe (temperature resistance min. 80 °C)	
– 1 m laid straight or 1 m straight pipe	1.0 m
– 45° bend (radius of bend = 0.25 m)	0.6 m
– 90° bend (radius of bend = 0.25 m)	0.8 m
Non-return flap*	14.3 m
* optional accessories	

Table II	
Maximum permissible total ducting length	Required diameter
20 m	100 mm
40 m	125 mm
80 m	150 mm

Sample calculation

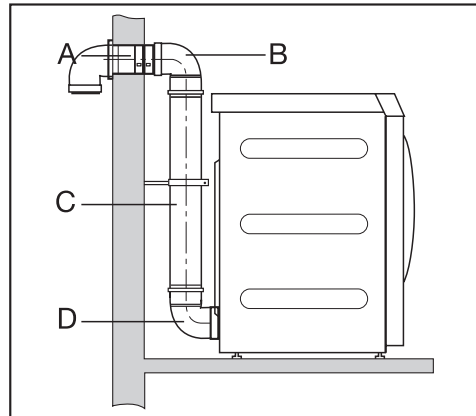

A	1 bend, 90° = 1 x 0.8 m relative pipe length	= 0.8 m
B/D	2 bends, 90° = 2 x 0.8 m relative pipe length	= 1.6 m
C	0.5 m pipe = 0.5 x 1 m relative pipe length	= 0.5 m
Total ducting length		= 2.9 m

Result: the total ducting length is less than 20 m (as per Table II). A pipe diameter of 100 mm will therefore suffice.

Exhaust air management with plug-in pipes

You will need

- the connector (supplied).
- pipes and connecting pieces from a suitable retailer.

Only use heat-resistant materials with a temperature resistance of at least 80 °C.

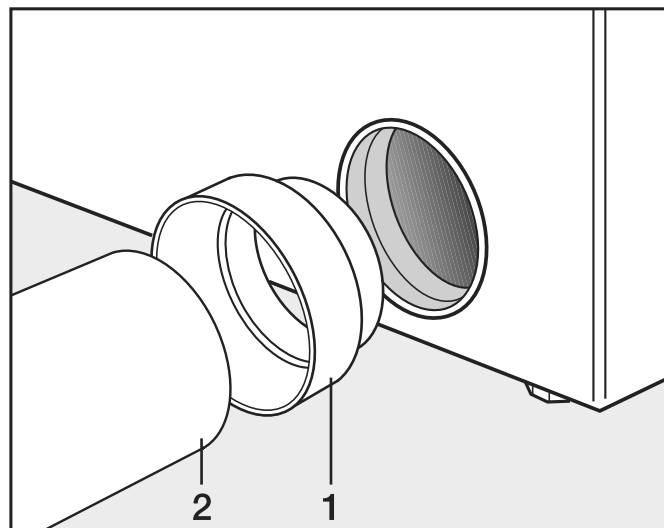

Installation notes

- Install the connector (1) and the pipe (2).

⚠ Wrap heat-resistant metallic tape around plug connections.

Exhaust air management with flexible aluminium hose

You will need

- the adapter (supplied).
- Flexible aluminium exhaust air hose (optional accessory).

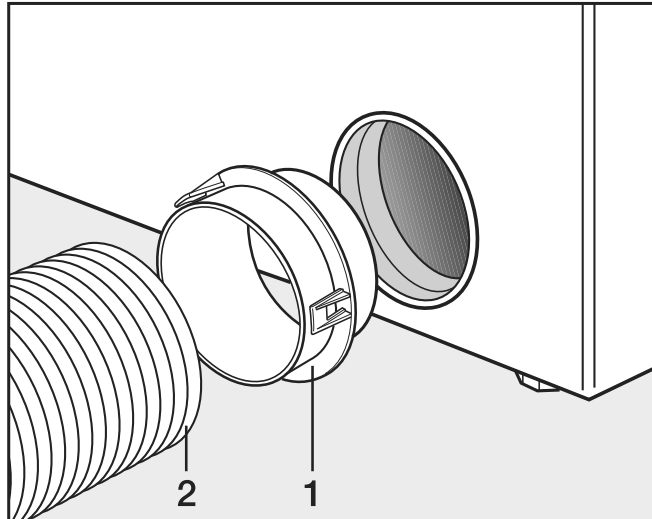

- Install the adapter (1) and the flexible aluminium exhaust air hose (2).

⚠ Wrap heat-resistant metallic tape around plug connections.

Shared exhaust air ducts

A shared exhaust air duct is only permitted in exceptional cases. The shared exhaust air duct must be approved by the relevant building inspector.

⚠ A non-return flap must be installed for each tumble dryer. Otherwise, the tumble dryers may be damaged by a backflow of condensation and their electrical safety could be affected.

If 3–5 tumble dryers are installed on one shared exhaust air duct, the pipe diameter **D** must be increased.

Number of tumble dryers	Factor for increasing the pipe diameters from Table II
3	1.25
4–5	1.5

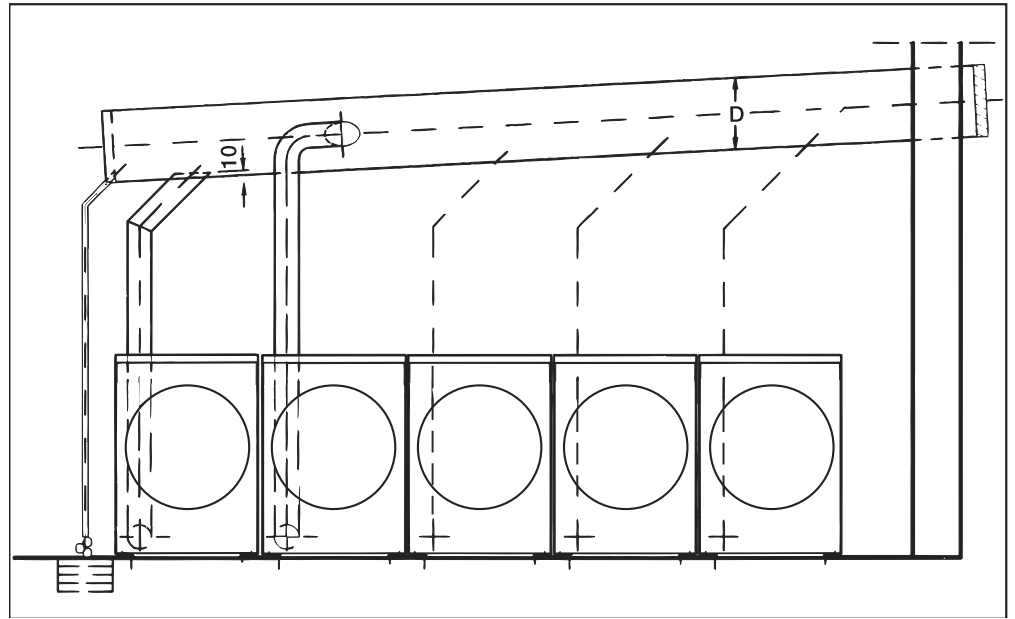

Installation notes

Optional accessories

Only use genuine Miele spare parts and accessories with this machine.

Using spare parts or accessories from other manufacturers will invalidate the warranty, and Miele cannot accept liability.

Washing machine accessories

Connector Box

The Connector Box allows external hardware from Miele and other suppliers to be connected to the Miele Professional washing machine. The Connector Box is supplied with mains voltage by the Miele Professional washing machine.

The separately available set consists of the Connector Box and fasteners for installation on the machine or on the wall.

Peak load / energy management

A peak-load or energy management system can be connected via the Connector Box.

The energy management system monitors the energy consumption of a system and deactivates individual pieces of equipment temporarily by means of the peak-load negotiation in order to ensure that certain total load limits are not exceeded.

When the peak-load function is activated, the heating is deactivated and the programme stopped. A message appears in the display to inform you of this.

The programme is resumed automatically when the peak-load function finishes.

Payment device

The washing machine can be fitted with a single-machine payment system as an optional accessory via the Connector Box.

The programming required for connecting a payment system can be carried out during the initial commissioning process. After initial commissioning, changes may only be carried out by your Miele dealer or the Miele Customer Service Department.

Please note that the status of the Connector Box must be set to “on” in the supervisor level as required. The payment system settings can be configured at the supervisor level.

The payment system is not activated via the supervisor level.

WiFi/LAN interface

The washing machine is equipped with a WiFi/LAN interface for exchanging data.

The data interface provided on the LAN connection complies with SELV (Safety Extra Low Voltage). The LAN connection uses a RJ45 connector in accordance with EIA/TIA 568-B.

Connected machines must also comply with SELV.

Tumble dryer accessories

Communication box	<p>The optional communication box allows external hardware from Miele and other suppliers to be connected to the Miele Professional machine.</p> <p>The communication box is supplied with mains voltage by the Miele Professional machine.</p> <p>The separately available set consists of the communication box and fasteners for installation on the machine or on the wall.</p>
Peak load / energy management	<p>A peak-load or energy management system can be connected via the Connector Box.</p> <div style="border: 1px solid black; padding: 5px;"><p>The energy management system monitors the energy consumption of a system and deactivates individual pieces of equipment temporarily by means of the peak-load negotiation in order to ensure that certain total load limits are not exceeded.</p></div> <p>When the peak-load function is activated, the heating is deactivated and the programme stopped. A message appears in the display to inform you of this.</p> <p>The programme is resumed automatically when the peak-load function finishes.</p>
Payment device	<p>Using the communication box, the tumble dryer can be fitted with an individual payment system as an optional accessory.</p> <p>The programming required for connecting a payment system can be carried out during the initial commissioning process. After initial commissioning, changes may only be carried out by your Miele dealer or the Miele Customer Service Department.</p>
APCL106	<p>The optional Miele communication module can be used to establish a data connection between a Miele Professional machine and a data processor in accordance with the Ethernet or WiFi standard.</p> <p>This communication module fits into the communication slot which is a standard feature on all machines. The communication module offers the option of intelligent app-based communication with external systems (such as central smart payment terminals or payment systems). In addition, it can display detailed machine and programme status information.</p> <p>This module forms the basis for wired communication with Miele MOVE.</p> <div style="border: 1px solid black; padding: 5px;"><p>It is not possible to integrate the machine into the “Miele@home” app for domestic installations.</p></div> <div style="border: 1px solid black; padding: 5px;"><p>The communication module is intended exclusively for commercial use and is supplied with mains voltage directly via the Miele Professional machine. No additional power connection is required. The Ethernet interface provided via the communication module complies with SELV (safety extra low voltage) requirements in accordance with EN 60950. Connected external machines must also comply with SELV.</p></div>

Installation

Standard

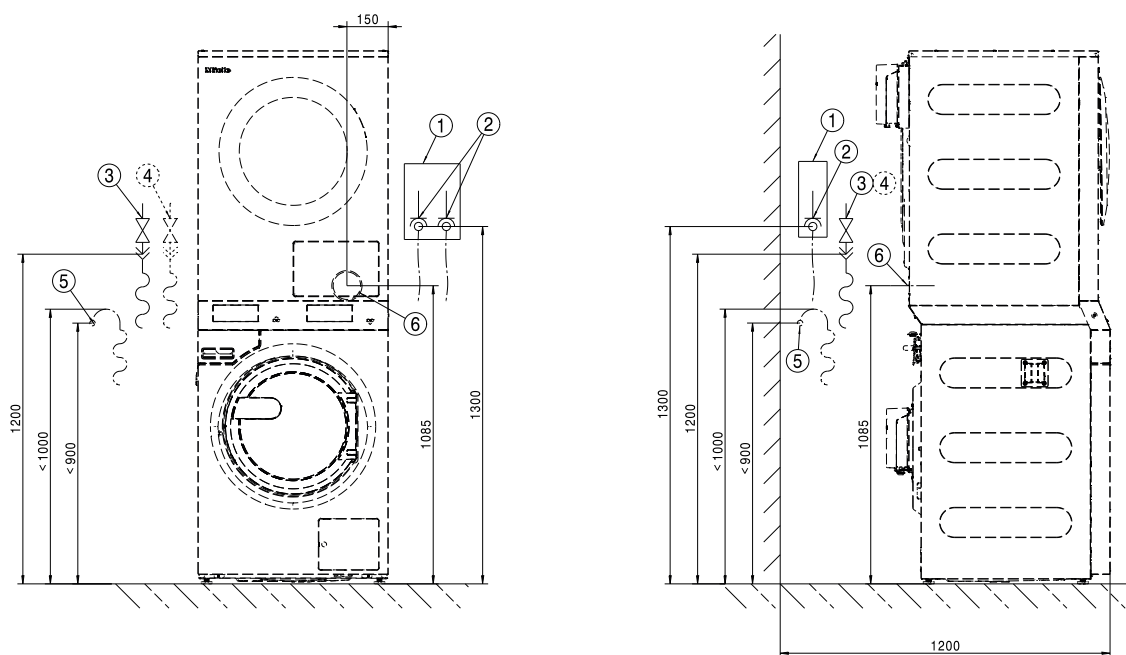

Dimensions in mm

- ① Isolator
- ② Electrical connection
- ③ Cold water connection
- ④ Hot water connection
- ⑤ Drain pump connection
- ⑥ Exhaust duct

Standard

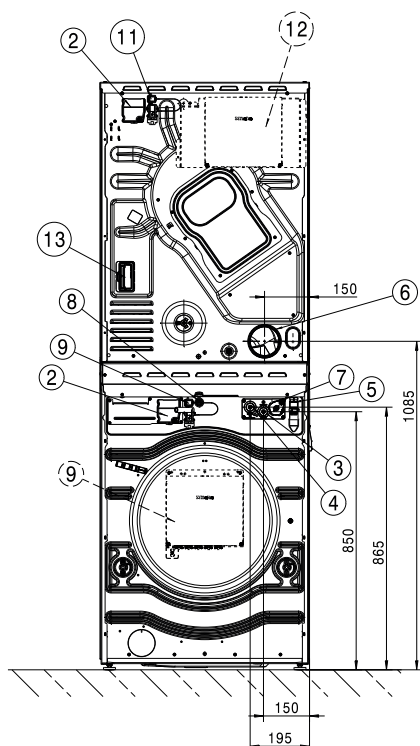

Dimensions in mm

- ① N/A
- ② Electrical connection
- ③ Cold water connection
- ④ Hot water connection
- ⑤ Drain pump connection
- ⑥ Exhaust duct
- ⑦ Dispenser pump connection
- ⑧ LAN connection
- ⑨ Connector Box connection
- ⑩ Connector Box (optional)
- ⑪ Connection for communication box
- ⑫ Communication box (optional)
For setting up a connection with external systems
- ⑬ Connection for communication module
The optional communication module can be used to establish a data connection in accordance with the Ethernet or WiFi standard.

Floor anchoring

Standard

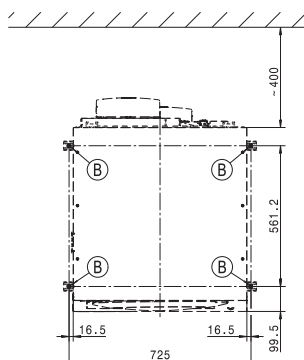
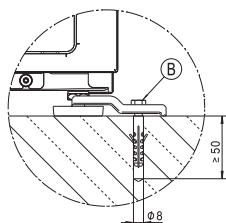

Dimensions in mm

ⓑ Screw/anchor point

Technical data

Voltage versions and electrical data

3N AC 400 V EL

	Washing machine	Tumble dryer
Supply voltage	3N AC 400 V	3N AC 400 V
Frequency	60 Hz	50/60 Hz
Required fuse rating (on site)	3 x 16 A	3x16 A
Circuit breaker trip characteristic	Type B	Type B
Power rating	8,2 kW	8,2 kW
Connection cable, min. cross-section	5 x 1,5 mm ²	1,5 mm ²

1N AC 230 V EL

	Washing machine	Tumble dryer
Supply voltage	1N AC 230 V	1N AC 230 V
Frequency	50 Hz	50/60 Hz
Required fuse rating (on site)	1 x 25 A	1x25 A
Circuit breaker trip characteristic	Type B	Type B
Power rating	5,5 kW	5,5 kW
Connection cable, min. cross-section	3 x 2,5 mm ²	2,5 mm ²

Plumbing

Cold water connection

Required flow pressure	100 - 1000 kPa (1 - 10 bar)
Maximum flow rate	10 l/min
Threaded union required (male thread, to be provided by customer in accordance with DIN 44991, flat sealing)	3/4"
Length of water inlet hose included in scope of supply	2000 mm

Hot water connection

Maximum permissible hot water temperature	60 °C
Required flow pressure	100 - 1000 kPa (1 - 10 bar)
Maximum flow rate	10 l/min
Threaded union required (male thread, in accordance with DIN 44991, flat sealing)	3/4"
Length of water inlet hose supplied	2000 mm

Drainage (DP)

Maximum waste water temperature	95 °C
Drain connection (on machine)	External diameter 22 (DN 22)
Maximum drainage rate	26 l/min

Air intake

Recommended free air intake cross-section into the room: (equivalent to 3 times the exhaust air cross-section of an appliance).	237 cm ²
--	---------------------

There must be sufficient air intake to the installation site to match the air outlet volume.

Vented system

Maximum nominal volume flow rate	320 m ³ /h
Maximum permitted pressure loss	420 Pa
Connector on machine side (external diameter)	100 mm
Connection pipe provided on site (internal diameter)	100 mm
Maximum exhaust air temperature	80 °C

As relative humidity inside the exhaust ducting can be as high as 100 %, suitable measures must be taken to prevent a backflow of condensate into the appliance.

Equipotential bonding

If local and national installation specifications require equipotential bonding, good galvanic contact must be guaranteed. Accessories for equipotential bonding are not supplied and need to be ordered separately.

Installation dimensions

Casing width (without add-on components)	692 mm
Casing height (without add-on components)	1012 mm
Casing depth (without add-on components)	718 mm
Overall machine width	700 mm
Overall machine height	1020 mm
Overall machine depth	730 mm
Minimum width of transport opening	800 mm
Minimum safety distance between wall and back of machine	400 mm
Diameter of door opening	370 mm
Door opening angle	180°

Standard

Required anchor points	4
DIN 571 wood screw (diameter x length)	12 mm x 90 mm
Rawl plugs (diameter x length)	14 mm x 80 mm

Transport data, weight and floor load

Packaging width	750 mm
Packaging height	1214 mm
Packaging depth	817 mm
Gross volume	744 l
Gross weight*	152 kg
Net weight*	140 kg
Maximum floor load in operation*	2421 N

*depending on equipment configuration

Emissions data

Workplace-related sound pressure level, washing	50 dB (A)
Sound power level, washing	59,2 dB (A)
Workplace-related sound pressure level, spinning	63 dB (A)
Sound power level, spinning	73 dB (A)
Average heat dissipation rate to installation room	3,9 MJ/h
Emission sound pressure level	63 dB (A) re 20 µPa

United Kingdom

Miele Co. Ltd., Fairacres, Marcham Road
Abingdon, Oxon, OX14 1TW
Professional Sales, Tel: 0845 365 6608
E-mail: professional@miele.co.uk
Internet: www.miele.co.uk/professional

Australia

Miele Australia Pty. Ltd.
ACN 005 635 398, ABN 96 005 635 398
Level 4, 141 Camberwell Road, Hawthorn East, VIC 3123
Tel: 1300 731 411
Internet: www.miele.com.au/professional
E-mail: professional.sales@miele.com.au

China Mainland

Miele Electrical Appliances Co. Ltd.
No. 82, Shimenyi Road, JingAn District,
Shanghai, China, P.R.C, Post Code: 200040
Phone: +86 21 6157 3500, Fax: +86 21 6157 3511
E-mail: info@miele.cn, Internet: www.miele.cn

Hong Kong, China

Miele (Hong Kong) Ltd.
41/F - 4101, Manhattan Place
23 Wang Tai Road, Kowloon Bay, Hong Kong
Tel: (852) 2610 1025, Fax: (852) 3579 1404
Email: customerservices@miele.com.hk
Website: www.miele.hk

India

Miele India Pvt. Ltd.
1st Floor, Copia Corporate Suites,
Commercial Plot 9, Mathura Road, Jasola,
New Delhi - 110025
E-mail: customercare@miele.in, Website: www.miele.in

Ireland

Miele Ireland Ltd.
2024 Bianconi Ave., Citywest Business Campus,
Dublin 24
Tel: (01) 461 07 10, Fax: (01) 461 07 97
E-Mail: info@miele.ie, Internet: www.miele.ie

Malaysia

Miele Sdn Bhd
Suite 12-2, Level 12
Menara Sapura Kencana Petroleum
Solaris Dutamas No. 1, Jalan Dutamas 1
50480 Kuala Lumpur, Malaysia
Phone: +603-6209-0288
Fax: +603-6205-3768

New Zealand

Miele New Zealand Limited
IRD 98 463 631
8 College Hill
Freemans Bay, Auckland 1011, NZ
Tel: 0800 464 353
Internet: www.miele.com.au/professional
E-mail: professional.sales@miele.com.au

Singapore

Miele Pte. Ltd.
29 Media Circle, #11-04 ALICE@Mediapolis
Singapore 138565
Tel: +65 6735 1191, Fax: +65 6735 1161
E-Mail: info@miele.com.sg
Internet: www.miele.sg

South Africa

Miele (Pty) Ltd
63 Peter Place, Bryanston 2194
P.O. Box 69434, Bryanston 2021
Tel: (011) 875 9000, Fax: (011) 875 9035
E-mail: info@miele.co.za
Internet: www.miele.co.za

United Arab Emirates

Miele Appliances Ltd.
Showroom 1, Eiffel 1 Building
Sheikh Zayed Road, Umm Al Sheif
P.O. Box 114782 - Dubai
Tel. +971 4 3044 999, Fax. +971 4 3418 852
800-MIELE (64353)
E-Mail: info@miele.ae
Website: www.miele.ae



Manufacturer: Miele & Cie. KG, Carl-Miele-Straße 29, 33332 Gütersloh, Germany