

Miele

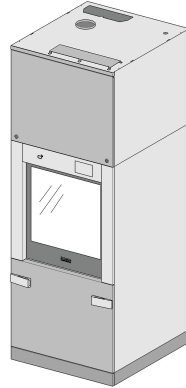

Installation plan

PLW 8615

en - US, CA

M.-Nr. 11 426 692

Contents

Information on the installation plan	3
Machine dimensions	4
Installation notes	6
Installation	6
Stand (FP).....	6
Mobile base (RP)	6
Top-box paneling (TC)	6
Paneling at the customer's site	6
Multiple side-by-side installation.....	6
Supply lines	7
Customer's installation area	7
Top-box paneling (TC) connections	8
Electrical connection	9
Clockwise rotation.....	9
Steam connection (optional).....	10
Compressed-air connection.....	10
Network connection	11
Network protocols.....	11
Water connection	12
Water inlet	12
Drainage	12
Exhaust duct	14
Steam condenser (optional)	15
Steam condenser (SC)	15
Connection module	16
Inputs.....	16
Potential-free outputs.....	17
Technical details	18
Dimensions.....	18
Weight	18
Electrical connection	18
Steam connection	19
Compressed-air connection.....	19
Exhaust air.....	19
Water inlet	20
Drainage	20
Cooling circuit* (optional)	21
Operating conditions.....	21
Storage and transportation conditions.....	21
Emission values.....	21
Heat dissipation.....	21
Sound pressure level	21

Information on the installation plan

For safe installation and commissioning of the laboratory glassware washer, please read the installation plan, the service documentation, the operating instructions, and the programming manual.

This installation plan includes the dimensions of the laboratory glassware washer, the technical data, and the requirements to be met by the customer for installation.

The laboratory glassware washer is generally referred to as “the machine” in these operating instructions.

The dimensions in the figures are given in inches (mm). Dimensions that deviate from this are labeled accordingly.

The machine features vary depending on the model and can be extended with additional options. The installation plan describes the maximum amount of possible features.

Individual connections are not required for each item of optional equipment, e.g., a steam connection or cold water for the steam condenser.

Optional extras

CT	Combi tank
DP	Drain pump
DU 900	Drying unit and top-box paneling
DU 900 RV	Drying unit and top-box paneling with air vents
EL	Electric heating
EL/S	Steam/electric heating
FP 900	Stand
RP 900	Mobile base
SC	Steam condenser
TC 900	Top-box paneling

Installation requirements

Installation and commissioning work should be performed by Miele Customer Service or a suitably authorized technician in accordance with local and national safety regulations.

Installation must comply with valid regulations, legal requirements, relevant standards, and accident prevention regulations.

Machine dimensions

Front view

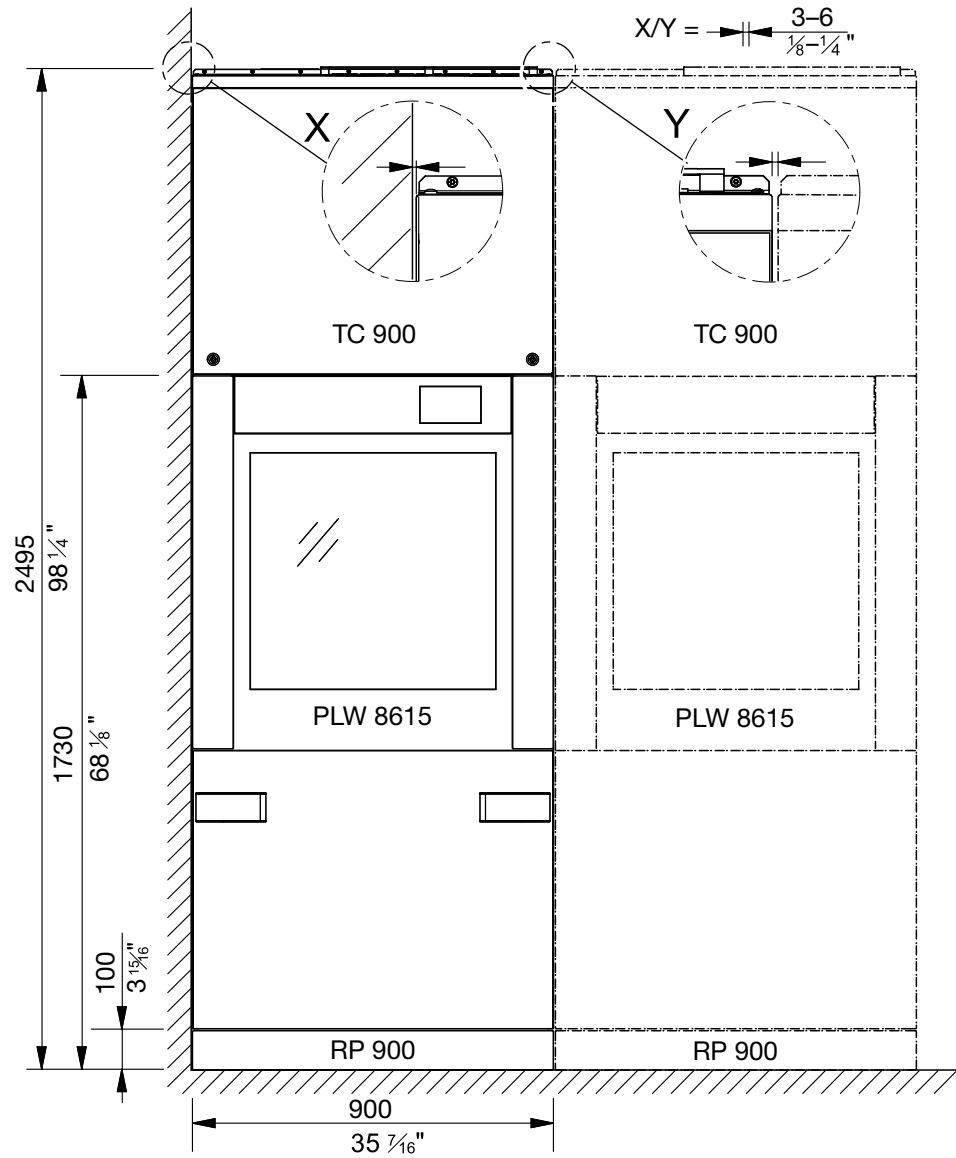

View from above - top-box paneling (TC)

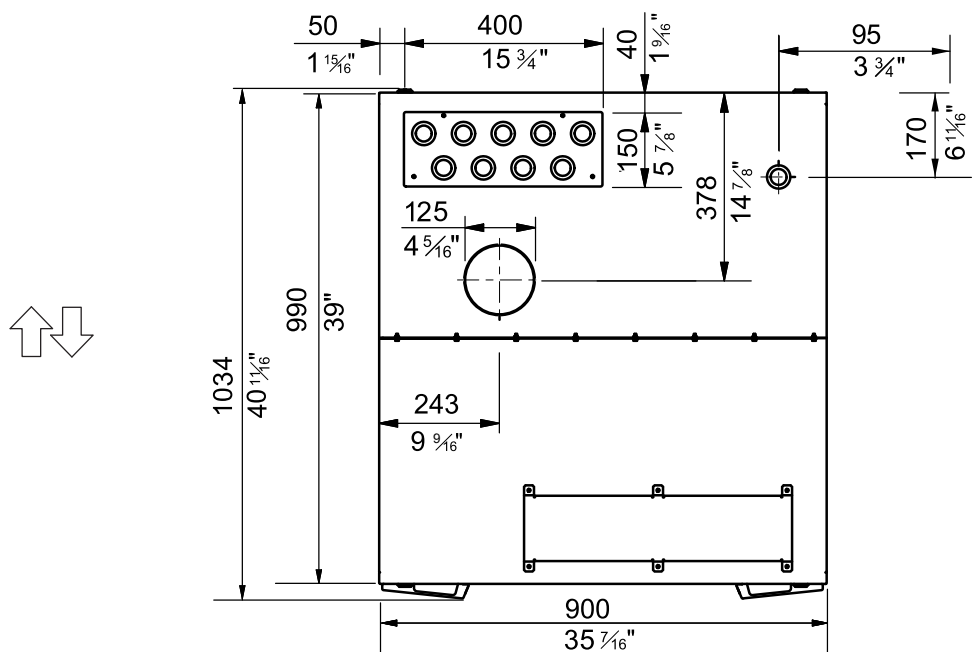

Machine dimensions

Side view

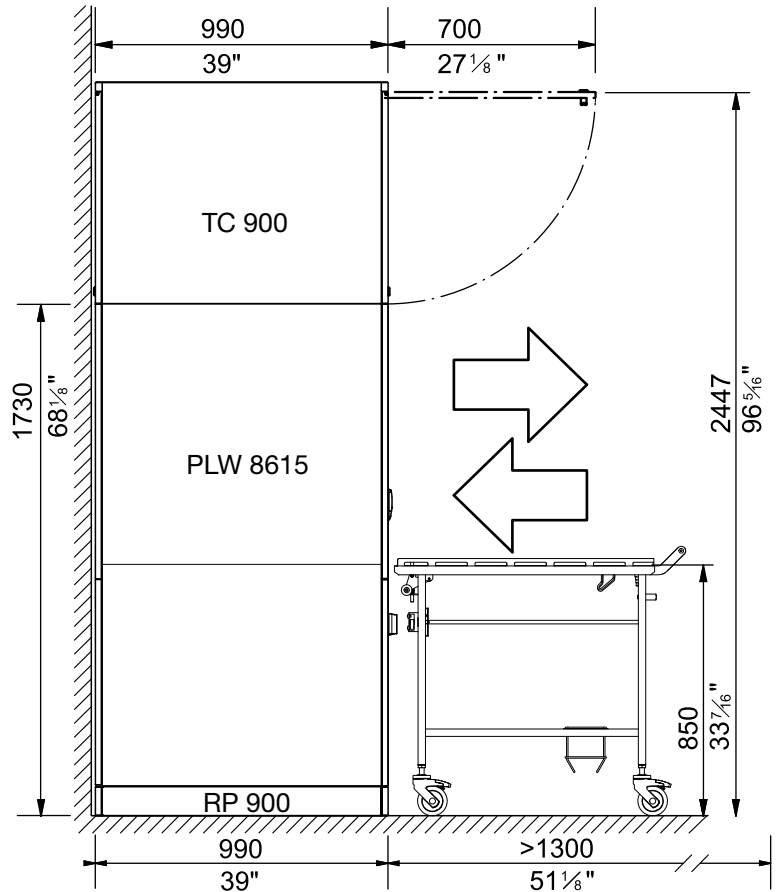

View from above plinth (FP)

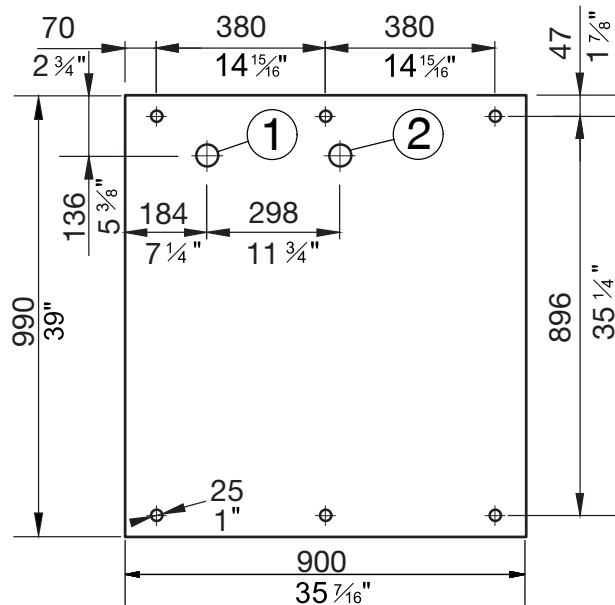

① Floor-tray drain



Loading/unloading direction

② Waste water

Installation notes

Installation

Stand (FP)

A stand is required to install the machine. The stand comes with height-adjustable feed and a drip tray, e.g., for condensation.

Mobile base (RP)

If the machine is installed with the rear side against a wall, a mobile base must be installed. This means that the machine can be moved away from the wall using the mobile base for maintenance and service work.

The machine must be equipped with a drain pump (optional) so that it can be moved with the mobile base.

Top-box paneling (TC)

The top-box paneling (TC) makes it possible to access the technical equipment above the wash cabinet, e.g., on drying units, for maintenance and service work. To enable the top-box paneling to be placed pre-assembled on the machine, a clear height of at least 8' 7" (2.62 m) is required. If the clear height is between 8' 2" (2.50 m) and 8' 7" (2.62 m), the top-box paneling must be removed. The individual parts are reassembled above the machine and then riveted again.

Mount the cover provided with watertight hose feed-throughs on the top-box paneling. If the shut-off valves or screw connections are leaky, the cover prevents water from getting into the machine.

Paneling at the customer's site

Install paneling with inspection flaps at the customer's site from the top-box paneling to the ceiling. The supply lines can be accessed from the outfeed of the machine.

Multiple side-by-side installation

Several machines can be installed next to one another in a row. A gap of 1/8"-1/4" (3–6 mm) is required between two machines or a machine and a partition wall.

The stands of the individual machines can be connected together.

Supply lines

The connections for the supply lines are on the machine above the top-box paneling.

The supply lines provided by the customer and the exhaust duct must end 8' 8" (2,650 mm) above the top edge of the finished floor so that the top-box paneling (TC) can be installed on the machine. For the supply lines in the second row of the installation area, a height of 9' 2" (2,800 mm) is recommended as this will mean that the shut-off valves are more easily accessible.

Customer's installation area

The customer's supply line must be above the machine. The installation area must be at least 18 7/8" x 5 7/8" (480 x 150 mm):

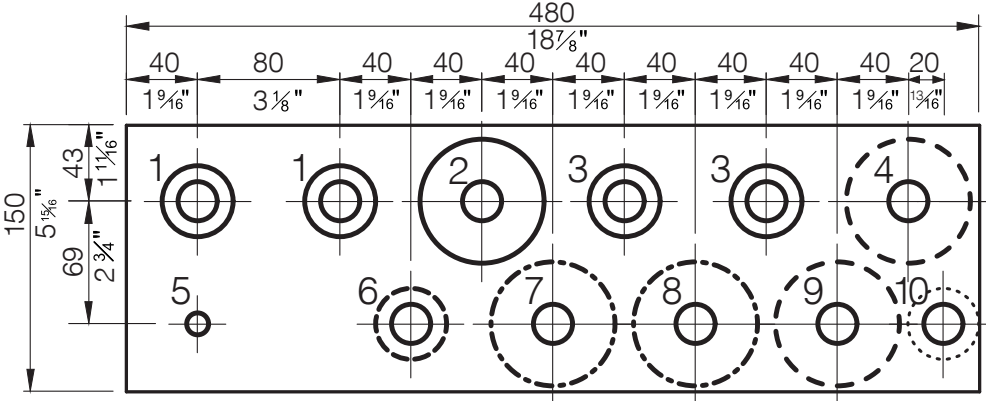

- ① 2 x DI water
- ② 1 x hot water
- ③ 2 x cold water
- ④ Cooling circuit, feed line (optional)
- ⑤ Compressed air, technical grade
- ⑥ Cold-water inlet, steam condenser (optional)
- ⑦ Supply line, steam (optional)
- ⑧ Condensate line, steam (optional)
- ⑨ Cooling circuit, return (optional)
- ⑩ Waste-water disposal line, drain pump (optional)

Installation notes

Top-box paneling (TC) connections The following lines are routed outside the installation area through the cover of the machine:

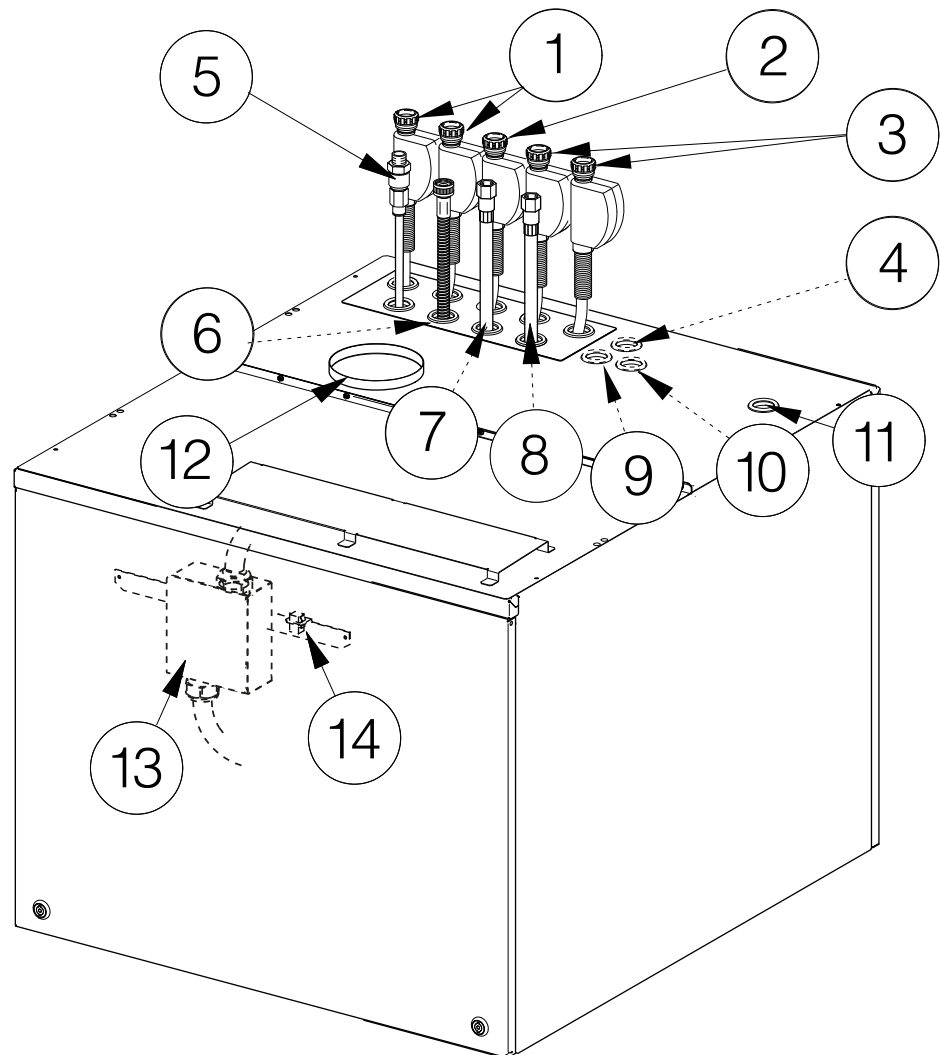

- ⑪ Implementation for:
 - Power cord
 - Data line
 - Equipotential bonding and grounding (optional)
 - External voltage for potential-free contacts on the connection module (optional)
 - Lines to the potential-free contacts on the connection module (optional)
- ⑫ Vent ducting
- ⑬ Power-cord connection box
- ⑭ Ethernet plug, data line

- ① to ⑩; see “Customer’s installation area”

Electrical connection

All work on the electrical connection must be carried out by Miele Customer Service or a qualified electrician.

The machine installation must comply with measurement category CAT II in accordance with IEC 61010-1.

The machine is connected to the electrical supply from above. You will need power cord at least 4' 11" (1,500 mm) long inside the top-box paneling.

The voltage may deviate from the rated voltage by max. $\pm 10\%$.

Power connection The connection box for the electrical connection is inside the top-box paneling. The power cord must be connected to the terminal block in the connection box at the customer's site.

Install a power switch capable of disconnecting the machine at all poles at the customer's site. This power switch must have a contact gap of at least 1/8" (3 mm).

The power switch must be accessible after the machine has been installed. This is to enable an electrical safety test to be carried out after installation and after any servicing work.
The power cord must be laid protected from the risk of thermal damage.

Residual current device (RCD) For added safety, each machine should be protected by a type B residual current device with a trip current of 30 mA.
The residual current device must be installed so that it is easily accessible.

Clockwise rotation Machine phases must be connected in the correct sequence (clockwise rotating field). The clockwise rotating field determines the direction of rotation of the machine's motorized drives.

Equipotential bonding and grounding The machine has been set up for equipotential bonding and grounding. The connection screw (M8) is on the infeed side above the lifting door.
Equipotential bonding and grounding should be carried out if possible on site.

Installation notes

Steam connection (optional)

Dual-heated machines with steam and electric heating (EL/S) must be connected to a dry industrial-steam supply. The hoses for steam and condensate can protrude from the top-box paneling by approx. 12" (300 mm).

A shut-off valve, a dirt trap, and drainage must be installed in the steam line.

To avoid impacts in the cold condensate lines when starting up the machine, install a non-return valve directly downstream of the condensate trap at the customer's site.

The customer's connections require the following outer threads, which seal the surface at the end:

- Supply line, steam 3/4"
- Drainage line, condensate 1/2"

Install shut-off valves for the steam and condensate lines at the customer's site.

The shut-off valves must be accessible after the machine has been installed.

Compressed-air connection

Oil-free, technical-grade compressed air is required to operate the machine door.

In machines with a steam connection, the technical-grade compressed air is also required to control the steam valves.

A shut-off valve and a coupling socket with 1/2" female quick lock is required at the customer's site for connection purposes.

The compressed-air hoses can protrude from the top-box paneling by approx. 3 ft (900 mm).

Network connection

The machine has an Ethernet interface. The RJ45 network connection is inside the top-box paneling above the wash cabinet.

A network connection is required above the machine at the customer's site. If the network cable and electrical connection are laid in parallel, you will need a 5 ft (1,500 mm) cable inside the top-box paneling. Use a CAT 5 network cable or better.

 Unauthorized access poses a health risk.

Settings in the machine, e.g., parameters for disinfection or dispensing process chemicals, may be changed as a result of unauthorized access via the network.

Under no circumstances should it be possible to access the machine via the Internet or other public or unsecured networks, either directly or indirectly (e.g., using port forwarding)!

The IP addresses from 192.168.10.1 to 192.168.10.255 are reserved for Miele Customer Service. They must never be set in the internal network.

1. The machine should be operated only in a separate network segment which meets one of the following requirements:
 - It is physically separated from other network segments
 - Access to the segment is restricted by a firewall or a router which has been configured accordingly
2. Limit access to this separate network segment to persons requiring access in the course of their work.
3. Use strong passwords to protect access to systems that are connected to the machine.
4. Configure the Ethernet interface.

The network connections and the connected machines must comply with IEC 62368-1.

Network protocols

The machine supports communication via the following network protocols:

Network protocols	Description	Port
DHCPv4	Assignment of dynamic IPv4 addresses	68/UDP
DHCPv6	Assignment of dynamic IPv6 addresses	546/UDP
HTTPS	Web interface for configuring the machine parameters	443/TCP

The ICMPv4 and ICMPv6 protocols are also supported.

Installation notes

Water connection

Water inlet

The machine must only be connected to fully vented pipework. A brief increase in the water pressure can damage components of the machine.

The quality of the incoming water must correspond to the drinking water specification of the country in which the machine is being operated.

The machine must be connected to hot, cold, and DI water. The water-inlet hoses can protrude from the top-box paneling by approx. 3 ft (900 mm). The customer's connections require a 3/4" outer thread, which seals the surface at the end. Install shut-off valves for the water-inlet hoses at the customer's site.

The shut-off valves must be accessible after the machine has been installed.

Drainage

The waste water must be received by a suitably dimensioned manifold \geq DN 100 with incline.

The drain lines must be heat resistant to at least 200°F (94°C). Install an odor trap at the customer's site.

If several machines are installed in a row, the manifold must be able to take the corresponding amount of waste water. If the waste water drains too slowly, you can increase the drainage time during the program sequence in the machine's controls. Also install a flow restrictor on the drain valve, e.g., a reducer or drain orifice.

Drain pump (DP)

The machine has a drain pump. The drain pump pumps the waste water to a floor drain or a drain line on the ceiling. The maximum delivery head is 9' 10" (3,000 mm).

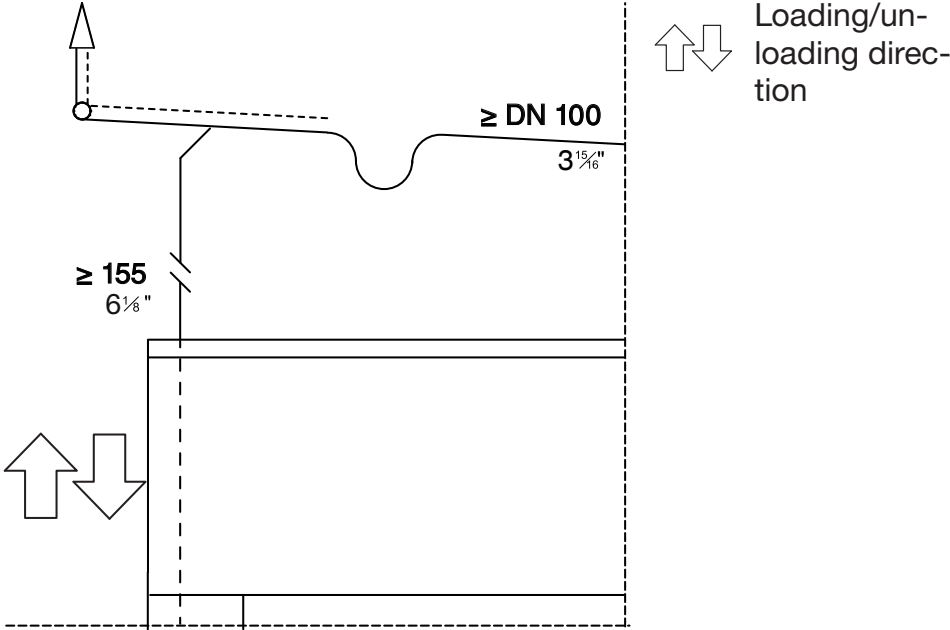

Detailed front view – top-box paneling

Drain line on the ceiling:
The drain hose is on the left-hand side of the machine viewed from the infeed side. The drain hose can protrude from the top-box paneling by approx. 2 ft (600 mm).

Floor drain:
The drain hose must be laid in a curve inside the machine so that the waste water cannot run back. The minimum delivery head is 8" (200 mm), measured above the non-return valve in the machine.

Installation notes

Exhaust duct

The machine must be connected to a ventilation or air-conditioning system. During operation, a permanent flow rate of 350 m³/h is required for the exhaust duct for each machine. There must be sufficient air intake via the ventilation system above the top-box paneling (TC) to match the air outlet volume. If there is no air-intake line, the top-box paneling must have vents on the infeed side.

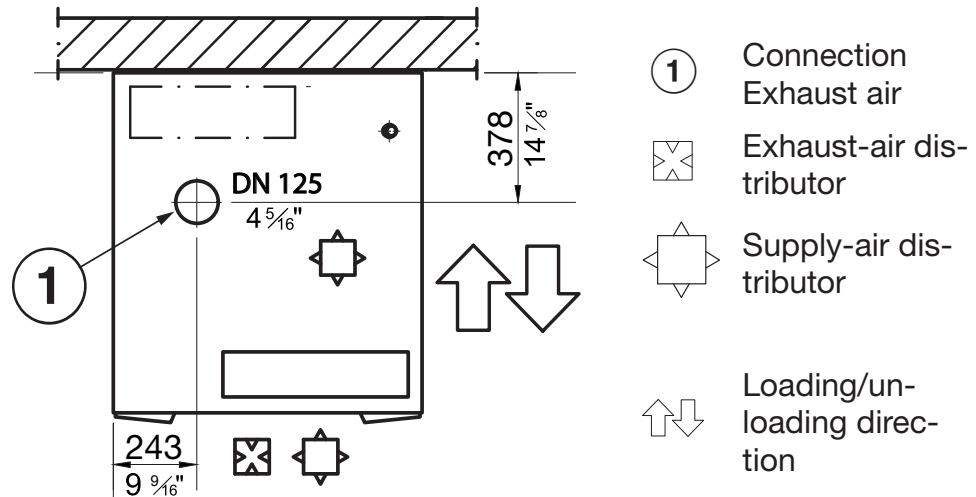

View from above – top-box paneling (TC)

If connected to an air-conditioning system, a steam condenser must be connected upstream to dehumidify the exhaust air.

If the machine is connected to an extraction system that is vented into the open air, you do not need a steam condenser.

Install the vent ducting sloping toward the exhaust airflow so that the condensate cannot run back into the machine. Drain the condensate line at the lowest point.

Install separate vent ducting for each machine if possible.

If the vent ducting for several machines need to be laid together, the output of the exhaust-air system on-site must be calculated and planned in line with the flow rate.

The heat dissipated during operation must be discharged via the ventilation system.

Steam condenser (optional)

If the machine's vent ducting is connected to an air-conditioning system, a steam condenser must be connected upstream to dehumidify the exhaust air.

The steam condenser must be operated together with a drying unit.

Install shut-off valves in the water inlet for the steam condenser at the customer's site.

The shut-off valves must be accessible after the machine has been installed.
--

Steam condenser (SC)

The steam condenser (SC) can be connected to the cold water or a cooling circuit at the customer's site.

Connection to cold water

You will need a cold-water connection at the customer's site for the steam-condenser water inlet. The connection hose has an internal diameter of 1/2" (13 mm).

The water is routed from the steam condenser into the machine's drain via a free-flowing section.

Connection to a cooling circuit

To connect the steam condenser to the cooling circuit, you will need a 3/4" regulating valve and a conversion kit with two connection hoses (optional accessories). The connection hoses have an internal diameter of 1/2" (13 mm) and are 78 3/4" (2,000 mm) long.

The solenoid valves supplied with the machine and the free-flowing section are not used.

Installation notes

Connection module

The machine is equipped with a connection module. Its potential-free inputs and outputs can be used to query operating statuses and control external components. The connection module has 3 plugs: plug 5 (yellow) with 4 inputs, plug 6 (green) with 5 outputs, and plug 7 (red) with 4 outputs.

The assignment of the inputs is fixed. The voltage at the inputs must be 200–240 V AC.

The assignment of the outputs can be set; see “Possible assignment of the potential-free outputs” table. The voltage at the outputs of a plug can be either 12–24 V DC or 200–240 V AC.

The same voltage must always be used at the outputs within a plug.

Damage to the relay contacts

The outputs on the connection module may only be loaded with max. 1 A to prevent damage to the relay contacts.

Attach external connector relays or contactors if higher ratings are switched at the connection-module outputs.

Inputs

- Peak-load negotiation of the electric heating
- Fill-level monitor for the external dispenser canister
- Flow control for the external dispenser pumps
- External message

Potential-free outputs

Parameter	The contact is activated ...
Off	–
Active drying	if the drying unit is active
Program running	while a program is running
Operation	when the machine is switched on
Fault	if a fault is present
Door status - Loading side	when the door is open on the infeed side
Unloading side status	when the door is open on the outfeed side
Program finished	between the end of the program and the door being opened
Pause with rinse	if the water intake is active in the pause program stage
Drainage Standard	if standard drainage is active in the program sequence
Drainage Recycling	if recycling drainage is active in the program sequence
Cold valve	during water intake through the set valve
Valve hot	
DI cold	
DI hot	
Cold valve delayed	during water intake through the set valve, a. delayed by the set “Water intake start delay” b. upstream by the set “Water intake stop delay”
Valve hot delayed	
DI cold delayed	
DI hot delayed	
DOS 7 external	as a signal for external dispenser pump 7
DOS 8 external	as a signal for external dispenser pump 8
DOS 9 external	as a signal for external dispenser pump 9
DOS 10 external	as a signal for external dispenser pump 10
DOS 1 control	when dispenser pump 1 is active
DOS 2 control	when dispenser pump 2 is active
DOS 3 control	when dispenser pump 3 is active
DOS 4 control	when dispenser pump 4 is active
DOS 5 control	when dispenser pump 5 is active
DOS 6 control	when dispenser pump 6 is active
External drainage contact	if the “External drainage contact” parameter is active during drainage

Technical details

Dimensions

Height incl. stand	69 11/16"	1770 mm
Height incl. stand and top-box paneling	98 1/4"	2495 mm
Width	35 7/16"	900 mm
Depth	39"	990 mm

Weight

Option	PLW 8615 EL	PLW 8615 EL
Net weight incl. stand and top-box paneling	996	452 kg
Net weight plus EL/S, DU, SC, CT	1376	624 kg
Max. operating weight	1764	800 kg
Max. individual load (foot 5 cm ²)	1308 N	1308 N
Max. distributed load (load-bearing capacity)	8.8 kN/m ²	8.8 kN/m ²
Optional extras		
Steam/electric heating (EL/S)	11 lbs	5 kg
Drying unit (DU)	254 lbs	115 kg
Steam condenser (SC)	115 lbs	52 kg
Combi tank (CT)	30 lbs	13.5 kg

Electrical connection

Voltage	3 AC 208 V	3 AC 208 V
Frequency	60 Hz	60 Hz
Fuse rating	3 x 60 A	3 x 60 A
Heater rating	18 kW	18 kW
Total rated load	21 kW	21 kW
Power cord cross-section	6/4 AWG	6/4 AWG
Customer's power cord, length within TC	59 1/16"	5 7/8 m
Connection	Mains junction box	Mains junction box

Dual-heated machines in "steam" heating mode (optional)

Fuse rating	3 x 30 A	3 x 30 A
Total rated load	10 kW	10 kW

Steam connection

Quality	Industrial steam, dry	Industrial steam, dry
Steam pressure (overpressure)	36–145 psi	250–1,000 kPa
Peak capacity for steam and condensate line	110 lbs/h	50 kg/h
Steam line at customer's site with shut-off valve, outer thread that seals the surface	3/4" GHT	3/4"
Condensate line at customer's site with shut-off valve, outer thread that seals the surface	1/2"	1/2"

Compressed-air connection

Compressed air, technical grade	ISO 8573-1: class 4	ISO 8573-1: class 4
Pressure	87–116 psi	600–800 kPa
Peak capacity	1.32 gpm	5 l/min
Connection at customer's site with shut-off valve and coupling socket with quick lock ♀	1/2"	1/2"

Exhaust air

Exhaust duct	DN 125	DN 125
Flow rate during operation	1,589 ft ³ /s	350 m ³ /h *
Temperature with steam condenser without steam condenser	113–118.4°F 158–203°F	45–48°C 70–95°C
Relative humidity with steam condenser without steam condenser	65–100% 80–100%	65–100% 80–100%

* The corresponding air intake must be routed inside the top-box paneling via the ventilation system; alternatively, if there is no air-intake line, top-box paneling with vents on the infeed side is available

Technical details

Water inlet

Water connections		
- Cold water	2	2
- Hot water	1	1
- DI water	2	2
Water temperature		
- Cold water	41–68°F	5–20°C
- Hot water	41–149°F	5–65°C
- DI water	41–149°F	5–65°C
Connection at customer's site with shut-off valve	3/4"	3/4"
Outer thread that seals the surface	Male garden-hose thread	
Water connection pressure	29–145 psi	200–1000 kPa
Flow rate	3.7 g/min	14 l/min
Max. water hardness	0.710 mmol/l 4 gpg	0.710 mmol/l 4°dH
DI water		
Recommended conductivity	<15 µS/cm	<15 µS/cm
Chloride content	<100 mg/l	<100 mg/l
pH value	5–8	5–8

Drainage

Drain pump (DP)

Max. water temperature	201°F	94°C
Max. transient flow rate	43 gpm	162 l/min
Min. delivery head	7 7/8"	200 mm
Max. delivery head	118 1/8"	3,000 mm
Hose inner diameter (Ø)	7/8"	22 mm
Drain line	≥ DN 100	≥ DN 100

Cooling circuit* (optional)

Cooling capacity	3.5 kW	3.5 kW
Spread	43/54°F	6/12°C
Max. connection pressure	800 kPa	800 kPa
Pressure loss in steam condenser	25 kPa	25 kPa

* In conjunction with a steam condenser

Operating conditions

Ambient temperature	41–104°F	5–40°C
Relative humidity:		
Minimum	10%	10%
Maximum for temperatures up to 201°F (31°C)	80%	80%
	50%	50%
Decreasing linearly for temperatures up to 104°F (40°C)		
Max. altitude above sea level up to	4,921'	1,500 m

Storage and transportation conditions

Ambient temperature	-4 to +140°F	-20 to +60°C
Relative humidity	10–85%	10–85%
Air pressure	500–1,060 hPa	500–1,060 hPa
Maximum floor load, transport route	6 kN	6 kN

Site-access dimensions including transport pallet

Height	77 3/16"	1960 mm
Width	39 3/8"	1000 mm
Depth	44 1/2"	1130 mm

Emission values

Heat dissipation

Infeed/outfeed side	600 W
Wash items after unloading	1,400 W

Sound pressure level

Sound pressure level LpA during cleaning and drying	<65 dB(A) re 20 µPa
---	---------------------



Please have the model and serial number of your machine available when contacting Technical Service.

Veuillez indiquer le modèle et le numéro de série de votre appareil lorsque vous contactez le service à la clientèle.

U.S.A.
Miele, Inc.

National Headquarters

9 Independence Way
Princeton, NJ 08540
Phone: 800-991-9380
www.mieleusa.com/professional
prosales@mieleusa.com

Technical Service & Support

Phone: 800-991-9380
proservice@mieleusa.com

Canada
Importer | Importateur
Miele Limited | Limitée

Professional Division

161 Four Valley Drive
Vaughan, ON L4K 4V8
Phone | Tél. : 1-888-325-3957
www.mieleprofessional.ca
professional@miele.ca

Miele Professional Technical Service | Service Technique

Phone | Tél. : 1-888-325-3957
serviceprofessional@miele.ca



Manufacturer | Fabricant : Miele & Cie. KG
Carl-Miele-Straße 29, 33332 Gütersloh, Germany | Allemagne