

Operating and installation instructions Induction hobs



It is **essential** to read the operating and installation instructions before setup, installation, and commissioning. This prevents both personal injury and damage to the appliance.

Warnings and safety notes	v		
Sustainability and environmental protection	1A		
Installation	Γ.		
Safety notes for installation	Γ.		
Additional safety notes for extraction mode	Γ1	Installing a surface-mounted hob with extraction and guided recirculation mode.....	38
Additional safety notes for Plug & Play mode	ΓΓ	Preparing the worktop for surface-mounted installation in extraction and guided recirculation mode	38
Additional safety notes for surface-mounted installation	ΓΕ	Installing a surface-mounted hob with extraction and guided recirculation mode.....	38
Additional safety notes for flush-fit installation	ΓΕ	Installing a surface-mounted hob with Plug & Play	38
Safety distances	Γ0	Preparing the worktop for surface-mounted installation with Plug & Play	38
Operating options.....	ΓA	Installing a surface-mounted hob with Plug & Play	39
Installation examples	ΓA	Installing a flush-fit hob with extraction and guided recirculation mode	39
Plug & Play adapter dimensions (KMDA 7676 FL-U only)	3.	Preparing the worktop for flush-fit installation in extraction and guided recirculation mode.....	39
Installation dimensions for surface-mounted installation	31	Installing a flush-fit hob with extraction and guided recirculation mode...	4.
KMDA 7676 FL-A, KMDA 7676 FL-U	31	Installing a flush-fit hob with Plug & Play	4.
Extraction and guided recirculation mode	3Γ	Preparing the worktop for flush-fit installation with Plug & Play	4.
Plug&Play mode	33	Installing a flush-fit hob with Plug & Play	41
Installation dimensions for flush-fit installation	3Ε	Rear wall cut-out without drilling template	43
KMDA 7676 FL-A, KMDA 7676 FL-U	3Ε	Creating the rear panel cut-out with surface-mounted installation and an installation distance (vertical)	
Extraction and guided recirculation mode	30	between the top of the appliance and the lowest point of the Plug &	
Plug&Play mode	3Γ	Play adapter of 238 mm	43
Connection to window contact, if required	3V		

Contents

Creating the rear panel cut-out with flush-fit installation and an installation distance (vertical) between the top of the appliance and the lowest point of the Plug & Play adapter of 238 mm .	ΕΕ	Special functions	0Λ
Creating the rear panel cut-out with surface-mounted installation and an installation distance (vertical) between the top of the appliance and the lowest point of the Plug & Play adapter of 248 mm	Ε0	Permanent pan recognition.....	0Λ
Creating the rear panel cut-out with flush-fit installation and an installation distance (vertical) between the top of the appliance and the lowest point of the Plug & Play adapter of 248 mm .	Ε1	Pan size recognition	0Λ
Electrical connection	ΕV	PowerFlex XL cooking area	0Λ
Familiarisation	Ε9	Hob power levels.....	0Λ
Your hob	Ε9	Hob Booster.....	0Λ
Features	01	Stop&Go	0Λ
Scope of delivery	01	Auto heat-up	0Λ
Optional accessories.....	0Γ	Timers	0Λ
Controls and indicators	0Ψ	System lock	0Λ
Cooking zone data.....	00	Lock.....	09
Power management	01	Recall.....	09
Operation.....	01	Keeping warm	09
Components	0V	Wipe protection.....	09
Grease filter	0V	Con@ctivity	09
Charcoal filter.....	0V	Guided recirculation mode.....	09
Networking.....	0V	Plug & Play mode.....	09
		Cooker hood power levels.....	09
		Cooker hood Booster function.....	09
		Run-on.....	09
		Operating hours counter.....	09
		Settings.....	1.
		Demo mode	1.
		Residual heat indicator	1.
		Safety switch-off.....	1.
		Overheating protection	11
		Model identifier and serial number	11
		Software version.....	11

Commissioning	1F	Changing the minute minder duration.....	1V
Unpacking the hob	1F	Deleting the minute minder duration .	1V
Cleaning the hob for the first time	1F	Setting the switch-off time.....	1V
Switching on the hob for the first time..	1F	Changing the switch-off time of a	
Using the vapour extractor for the first	1F	cooking process.....	1V
time.....		Deleting the switch-off time for a	
Networking.....	1F	cooking process.....	1A
Connecting to a network via the app	1F	Setting the switch-off time for further	
Connecting to a network via WPS....	1F	cooking processes	1A
Operation	1E	Displaying the switch-off time of a	
Safety notes for operation.....	1E	cooking process.....	1A
Switching the hob on.....	1E	Using both timer functions at the	
Switching the hob/a cooking zone off...	1E	same time	1A
Hob power levels.....	10	System lock	1A
Setting the power level.....	10	Activating the system lock	1A
Setting the power level – intermedi-		Deactivating the system lock	1A
ate levels.....	10	Lock	19
Changing the power level.....	10	Activating the safety lock.....	19
Booster	10	Deactivating the safety lock	19
Activating the Booster.....	10	Activating the Recall function.....	19
Deactivating the Booster.....	10	Activating/deactivating the Keep-	
Stop&Go	11	ing warm function.....	19
Activating Stop&Go.....	11	Wipe protection	19
Deactivating Stop&Go.....	11	Activating wipe protection	19
Auto heat-up	11	Deactivating wipe protection	19
Activating auto heat-up.....	11	Vapour extraction	19
Deactivating auto heat-up.....	11	Manually setting the cooker hood	
Timers	1V	power level.....	19
Setting the time.....	1V	Manually switching off the cooker	
Setting the minute minder	1V	hood	V·

Contents

Activating the Booster	V.	Cleaning the cover grille in the dish-	
Deactivating the Booster	V.	washer	ΛΕ
Deactivating Con@ctivity temporarily	V.	Grease filter	Λ0
Run-on	V.	Removing the grease filter	Λ0
Activating/deactivating demo mode	V.	Cleaning the grease filter by hand.....	Λ0
Setting ranges for the hob power		Cleaning the grease filter in the dish-	
levels	VΓ	washer	Λ0
Notes for test institutes	VΓ	Fitting the grease filters.....	Λ0
Good to know	VΕ	Replacing the grease filter	Λ0
Your hob	VΕ	Resetting the grease filter operating	
How induction hobs work	VΕ	hours counter	Λ0
Noises	VΕ	Charcoal filter (only KMDA 7676 FL-U)	Λ1
Cookware	VΕ	Replacing the charcoal filter (only	
Your cooker hood	V1	KMDA 7676 FL-U)	Λ1
How the cooker hood works	V1	Resetting the charcoal filter operat-	
Air extraction tips	V1	ing hours counter (only KMDA 7676	
Adjusting settings	VΛ	FL-U)	Λ1
Displaying the model identifier/serial		Cleaning the cooker hood drip tray.....	Λ1
number.....	ΛΓ	Cleaning inside the cooker hood casing	Λ1
Displaying the software version	ΛΓ	Cleaning the inside of the fan unit	ΛV
Cleaning and care	ΛΡ	Troubleshooting	ΛΛ
Safety notes on cleaning and care	ΛΡ	Messages in the display	ΛΛ
When to clean.....	ΛΡ	Unexpected behaviour.....	Λ9
Cleaning the ceramic glass surfaces	ΛΡ	Unsatisfactory results.....	9.
Unsuitable cleaning agents.....	ΛΕ	General problems or technical faults.....	91
Parts suitable for dishwashers	ΛΕ	Customer Service	9Ρ
Cover grille.....	ΛΕ	Contact in the event of a fault	9Ρ
Removing the cover grille.....	ΛΕ	Data plate	9Ρ
Cleaning the cover grille by hand	ΛΕ	Warranty	9Ρ

Technical data	၅၉
Technical data	၅၉
Product data sheets	၅၉
EU Conformity declaration.....	၅၀
UK Conformity declaration	၅၀

Warnings and safety notes

This hob complies with all relevant local and national safety requirements. Inappropriate use can, however, lead to personal injury and material damage.

Read the operating and installation instructions carefully before using the hob. They contain important information on safety, installation, use and maintenance. This prevents both personal injury and damage to the hob.

In accordance with standard IEC 60335-1, Miele expressly and strongly advises that you read and follow the instructions in the chapter on installing the hob as well as the warnings and safety notes.

Miele cannot be held liable for injury or damage caused by non-compliance with these instructions.

Keep the operating and installation instructions in a safe place and pass them on to any future owner.

Correct application

- ② This hob is intended for domestic use and use in other similar environments.
- ② This hob is not intended for outdoor use.
- ② It is intended for domestic use only to cook food and keep it warm. Any other use is not supported by the manufacturer and could be dangerous.
- ② This hob is not intended for use by people with reduced physical, sensory or mental capabilities or lack of experience and knowledge, unless they have been given supervision and instruction concerning its use by a person responsible for their safety. They may only use the hob unsupervised if they have been shown how to use it in a safe way. They must be able to recognise and understand the dangers of misuse.

Safety with children

- ② Children under 8 years of age must be kept away from the hob unless they are constantly supervised.
- ② Children over 8 years of age may use the hob without supervision if its operation has been clearly explained to them and they are able to use it safely. Children must be able to understand and recognise the possible dangers caused by incorrect operation.
- ② Children must not be allowed to clean the hob unsupervised.
- ② Children should be supervised in the vicinity of the hob. Never allow children to play with the hob.
- ② The hob gets hot when in use and remains hot for a while after being switched off. Keep children well away from the hob until it has cooled down and there is no danger of burning.
- ② Danger of burning. Do not store anything which might arouse a child's interest in storage areas above or behind the hob. Otherwise they could be tempted to climb onto the hob.
- ② Risk of burning and scalding. Place pots and pans on the cooking zone in such a way that children cannot pull them down and burn themselves.
- ② Danger of suffocation! Whilst playing, children may become entangled in packaging material (such as plastic wrapping) or pull it over their head with the risk of suffocation. Keep packaging material away from children.
- ② Activate the system lock to ensure that children cannot switch on the hob inadvertently. Use the safety lock when the hob is in use to prevent children from altering the settings selected.

Warnings and safety notes

Technical safety

- Ⓢ Unauthorized installation, maintenance or repairs could result in unforeseen dangers for the user, for which the manufacturer cannot accept liability. Installation, maintenance or repairs must only be carried out by a qualified specialist or Miele Customer Service.
- Ⓢ Damage to the hob can compromise your safety. Check the hob for visible signs of damage. Do not use the hob if it is damaged.
- Ⓢ Temporary or permanent operation on an autonomous power supply system or a power supply system that is not synchronised with the mains power supply (e.g. island networks, back-up systems) is possible. A prerequisite for operation is that the power supply system complies with the specifications of EN 50160 or an equivalent standard. The function and operation of the protective measures provided in the domestic electrical installation and in this Miele product must also be maintained in isolated operation or in operation that is not synchronised with the mains power supply, or these measures must be replaced by equivalent measures in the installation. As described, for example, in the current version of BS OHSAS 18001–2 ISO 45001.
- Ⓢ The electrical safety of this hob can only be guaranteed when correctly earthed. It is essential that this basic safety requirement is fulfilled. If in doubt, the electrical installation should be checked by a qualified electrician.
- Ⓢ The connection data (voltage and frequency) on the data plate of the hob must match the mains power supply in order to avoid the risk of damage to the hob.
Compare this data before connecting the appliance. If in any doubt, consult a qualified electrician.

Warnings and safety notes

- ⓘ Do not connect the hob to the mains electrical supply by a multi-socket adapter or extension lead. These are a fire hazard and do not guarantee the required safety of the appliance.
- ⓘ For safety reasons, this hob may only be used after it has been built in.
- ⓘ This hob must not be used in a non-stationary location (e.g. on a ship).
- ⓘ Any contact with live connections or tampering with the electrical or mechanical components of the hob will endanger your safety and may lead to the hob malfunctioning.
Do not open the hob housing under any circumstances.
- ⓘ The manufacturer's warranty will be invalidated if the hob is not repaired by a qualified specialist or by Miele Customer Service.
- ⓘ We recommend replacing defective components with original spare parts. Miele can only guarantee the safety of the appliance when genuine Miele replacement parts are used.
- ⓘ The hob is not intended for use with an external timer switch or a remote control system.
- ⓘ The hob must be connected to the mains power supply by a qualified electrician.
- ⓘ If the mains connection cable is damaged, it must be replaced with a special mains connection cable by a qualified specialist or Miele Customer Service.

Warnings and safety notes

- ⚠ During installation, maintenance and repair work, the hob must be completely disconnected from the electricity supply. It is only completely isolated from the electricity supply when:
- The mains fuse has been disconnected or
 - The screw-out fuses have been fully unscrewed or
 - The mains plug (if present) is removed from the socket. To do this, pull the mains plug and not the mains connection cable.
- ⚠ Risk of electric shock. Do not use the hob if it is faulty, or if the ceramic surface is cracked, chipped or damaged in any way. Switch it off immediately. Disconnect the hob from the mains power supply. Contact a qualified specialist or Miele Customer Service.
- ⚠ If the hob is installed behind a furniture front, do not close the door while the hob is in use. Heat and moisture can build up behind the furniture front when closed. This can result in damage to the hob, the housing unit and the floor. Do not close the furniture front until the residual heat indicators go out.
- ⚠ In areas which may be subject to infestation by cockroaches or other vermin, pay particular attention to keeping the appliance and its surroundings clean at all times. Any damage caused by cockroaches or other vermin will not be covered by the warranty.

Using at the same time as other heating appliances that depend on the air from the room

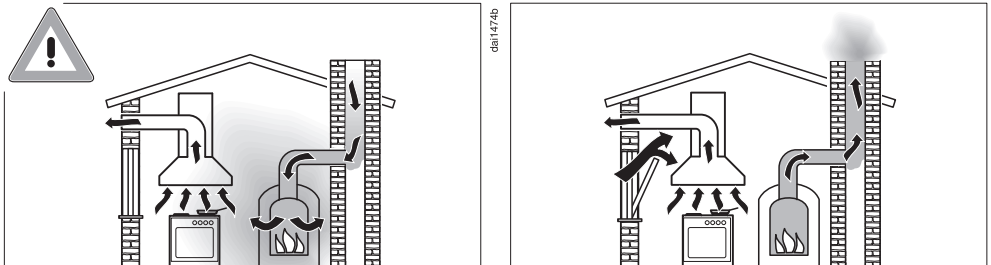

Warnings and safety notes

Danger of toxic fumes!

Great care should be taken when using the cooker hood in the same room or the same area of the house as another heating appliance that depends on the air from the room.

Such heating appliances draw in air from the room and duct exhaust gases out through a chimney or extraction ducting. They include gas, oil, wood and coal-fired boilers and heaters, continuous flow or other water heaters, gas hobs and ovens.

The cooker hood draws in air from the kitchen and from neighbouring rooms. This applies to the following modes of operation:

- extraction mode,
- recirculation mode with a recirculation box installed outside the room.

If there is insufficient air, an underpressure will occur. The heating appliance may be starved of oxygen. This impairs combustion. Harmful gases could be drawn from the chimney or extraction ducting back into the room, with potentially fatal consequences. Risk of death!

In order to ensure safe operation and to prevent gases given off by the heating appliance from being drawn back into the room, when the cooker hood and the heater are both operated simultaneously, an underpressure in the room of 0.04 mbar (4 Pa) is the maximum permissible.

Sufficient ventilation can be maintained by air inlets which cannot be blocked, e.g. in windows, doors and outside wall vents. The diameter of the inlet openings must enable sufficient ventilation. A ventilation brick alone is not generally sufficient to ensure safe ventilation.

The overall ventilation condition of the dwelling must be taken into account. If in any doubt, the advice of a competent builder, or for gas, a qualified gas fitter should be sought.

If the cooker hood is being operated in recirculation mode, where the air is passed back into the room in which the extractor is installed, the above restrictions do not apply.

Warnings and safety notes

Correct use

⊗ The hob gets hot when in use and remains hot for quite a while after being switched off. There is a risk of burning until the residual heat indicators go out.

⊗ Oil and fat can overheat and catch fire. Do not leave the hob unattended when cooking with oil and fat. If it does ignite do not attempt to put the flames out with water.

Disconnect the hob from the mains and use a suitable fire blanket, saucepan lid, damp towel or similar to smother the flames.

⊗ Do not leave the hob unattended whilst it is being used. It should be continually monitored whilst boiling and flash frying.

⊗ Open flames are a fire hazard.

Do not flambé food. When switched on, the cooker hood could draw flames into the filter. Kitchen grease deposits could ignite.

⊗ Spray canisters, aerosols and other inflammable substances can ignite when heated. Therefore do not store such items or substances in a drawer under the hob. Cutlery inserts must be heat-resistant.

⊗ Do not heat an empty pan.

⊗ Do not heat up food in closed containers e.g. tins or sealed jars on the hob, as pressure can build up in the container, causing it to explode.

⊗ Do not cover the hob, e.g. with a hob cover, a cloth or protective foil. The material could catch fire, shatter or melt if the hob is switched on by mistake or if residual heat is still present.

Warnings and safety notes

- ⓘ When the hob is switched on either deliberately or by mistake, or when there is residual heat present, there is the risk of metal items placed on the hob heating up. Other materials can melt or catch fire. Damp pan lids might adhere to the ceramic surface and be difficult to dislodge. Do not use the hob as a resting place for anything. Always switch the cooking zones off after use.
- ⓘ Switch the hob off after use. Do not wait until the hob switches off automatically because there is no longer any cookware on it. This can cause food to catch fire.
- ⓘ You could burn yourself on the hot hob. Protect your hands with heat-resistant pot holders or gloves when working on the hot hob. Do not let them get wet or damp. Heat transfers through damp and wet material more quickly with the risk of scalding or burning yourself.
- ⓘ Hot cooking vapours during cooking can cause the cooker hood to get hot.
Do not touch the casing or the grease filters until the cooker hood has cooled down.
- ⓘ When using an electrical appliance (e.g. a hand mixer) near the hob, ensure that the cable of the electrical appliance cannot come into contact with the hot hob. The cable's insulation could become damaged.
- ⓘ Grains of salt, sugar, or sand (e.g. from cleaning vegetables) can cause scratches if they get under the cookware. Make sure the ceramic glass surface and the underside of the cookware are clean before placing down the cookware.
- ⓘ Even a light object can cause damage in certain circumstances. Do not drop anything on the ceramic surface.
- ⓘ Hot items placed down on the sensor controls and displays can damage the electronic modules underneath. Never place hot pots or pans on the sensor controls and displays.

Warnings and safety notes

- ⓘ Do not allow solid or liquid sugar, or pieces of plastic or aluminium foil to get onto the hob when it is hot, as they can damage the ceramic surface when it cools down. If this should occur, turn off the hob immediately and scrape off all the sugar, plastic or aluminium residues while still hot, using a shielded scraper blade. Wear oven gloves when doing this. Allow the ceramic surface to cool down and then clean it with a suitable ceramic glass cleaner.
- ⓘ Do not heat empty pans on the hob as this can damage the ceramic glass and/or the cookware. Never leave the hob unattended during use!
- ⓘ Rough bases can scratch the ceramic glass. Use only pots and pans with smooth bases.
- ⓘ Always lift cookware to move it. This will help prevent scratching.
- ⓘ Because induction heating works so quickly, the base of the cookware could, under certain circumstances, heat up to the temperature at which oil or fat self-ignites within a very short time. Never leave the hob unattended during use!
- ⓘ Heat oil or fat for a maximum of one minute. Never use the Booster function to heat oil or fat.
- ⓘ For people fitted with a heart pacemaker: please note that the area immediately surrounding the hob is electromagnetically charged when it is switched on. It is very unlikely to affect a pacemaker. However, if in any doubt, consult the manufacturer of the pacemaker or your doctor.
- ⓘ When switched on, the electromagnetic field of the hob can impair the function of magnetisable objects. Do not leave credit cards, digital storage devices, pocket calculators, etc. in the immediate vicinity of the hob.
- ⓘ Metal utensils stored in a drawer under the hob can become hot if the appliance is used intensively for a long time.

Warnings and safety notes

- ② The hob is fitted with a cooling fan. If a drawer is fitted directly underneath the hob, ensure that there is sufficient space between the drawer and its contents and the underside of the hob in order to ensure sufficient ventilation for the hob.
- ② If a drawer is fitted directly underneath the hob, do not store any pointed or small items, paper, serviettes, etc. in the drawer. They could get in through the ventilation slots or be sucked into the casing by the fan and damage the fan or impair cooling.
- ② Never use two items of cookware on a cooking zone or PowerFlex cooking area at the same time.
- ② If the cookware only partially covers a cooking zone or extended zone, the handle could become very hot.
Always place cookware in the middle of a cooking or extended zone!
- ② Only use the PowerFlex cooking area for rectangular or oval oven dishes.
- ② Deposits of grease and dirt will prevent the cooker hood from working properly.
Do not use the cooker hood without the grease filters in place. Otherwise cooking vapours will not be cleaned.
- ② There is a risk of fire if cleaning is not carried out as described in these operating instructions.
- ② Do not cover the vapour extraction cover grille when in use.
- ② Do not place hot cookware on the vapour extraction cover grille. This will impair the function of the vapour extraction and may damage the cover grille.
- ② Liquids can damage the cooker hood if they get into it. Keep liquids away from the cooker hood.

Warnings and safety notes

ⓘ Light objects can be drawn into the cooker hood and impair its operation. Do not place any light objects (e.g. paper towels) within close proximity of the cooker hood.

ⓘ The induction generators could be damaged or even destroyed if you use an induction adapter plate for cookware. Do not use induction adapter plates.

Cleaning and care

ⓘ The steam from a steam cleaner could reach live electrical components and cause a short circuit.

Do not use a steam cleaner to clean the hob.

ⓘ If the hob is installed above a pyrolytic oven or cooker, do not use the hob during a pyrolytic cleaning programme as this could trigger the overheating protection mechanism on the hob.

Accessories

ⓘ We recommend using original Miele accessories. If other parts are used, warranty, performance and/or product liability claims will be invalidated.

ⓘ Miele original spare parts are kept in stock for at least 10 years and up to 15 years after discontinuation of your hob.

Energy saving tips when cooking

- Cook in covered pots and pans if possible. This prevents heat escaping unnecessarily.
- Cook with as little water as possible.
- Once food has come to the boil or the pan is hot for frying, reduce the heat to a lower power level.
- Use a pressure cooker to reduce cooking durations.

Energy saving tips when operating the cooker hood

- It is important to ensure that the kitchen is well ventilated during operation. In extraction mode if there is insufficient air flow, the cooker hood cannot operate efficiently and this causes increased operating noise levels.
- Always cook with the lowest possible setting. This produces fewer cooking vapours, so you can use a lower power level on the cooker hood and therefore benefit from reduced energy consumption.
- Check the power level on the cooker hood. A low power level is usually sufficient. Only use the Booster level when necessary.
- When a large volume of cooking vapours are being produced, switch to a high power level in good time. This is more efficient than operating the cooker hood for longer to try to capture cooking vapours which have already been distributed throughout the kitchen.
- Switch the cooker hood off after cooking.
- Clean or replace the filters at regular intervals. Heavily soiled filters reduce performance, increase the risk of fire and are unhygienic.

Disposing of the packaging material

The packaging material is used for handling and protects the appliance from transport damage. The packaging material used is selected from materials which are environmentally friendly for disposal and can generally be recycled.

Recycling the packaging material reduces the use of raw materials. Use material-specific collection points for valuable materials and take advantage of return options. Your Miele dealer will take the packaging material away.

Disposing of your old appliance

Electrical and electronic appliances contain many valuable materials. They also contain certain materials, compounds and components which were essential for their correct functioning and safety. These could be hazardous to human health and to the environment if disposed of with household waste or if handled incorrectly. Please do not, therefore, dispose of your old appliance with household waste.



Instead, please make use of officially designated collection and disposal points to dispose of and recycle electrical and electronic appliances in your local community, with your dealer or with Miele, free of charge. By law, you are solely responsible for deleting any personal data from the old appliance prior to

Sustainability and environmental protection

disposal. You are legally obliged to remove any old batteries which are not securely enclosed by the appliance and to remove any lamps without destroying them, where this is possible. These must be taken to a suitable collection point where they can be handed in free of charge. Please ensure that your old appliance poses no risk to children while being stored for disposal.

Safety notes for installation

 Risk of damage from incorrect installation.

Incorrect installation can cause damage to the hob.

The hob must only be installed by a qualified specialist.

 Risk of electric shock from mains voltage.

Incorrect connection to the mains supply may result in an electric shock.

The hob must be connected to the electrical supply by a qualified electrician only.

 Damage from falling objects.

Take care not to damage the hob when fitting wall units or a cooker hood above it.

Fit the wall units and the cooker hood before the hob.

Dismantling the hob for service purposes may damage the sealing strip underneath the edge of the hob.

Always replace the sealing strip before reinstalling.

 The hob must not be installed over refrigeration appliances, dishwashers, washing machines, washer-dryers or tumble dryers.

 This hob may only be installed above a cooker or oven if they have a built-in cooling fan.

 A gas hob must not be installed next to this hob.

 Ensure that the mains connection cable cannot be touched after the hob has been installed.

 After installation, the mains connection cable of the hob must not come into contact with any moving kitchen components (such as a drawer) or be subject to mechanical loads.

 The veneers or laminate coatings of worktops must be treated with 100 °C heat-resistant adhesive so they do not come loose or warp. Any wall strips must be of heat-resistant material.

 The crossbeams in front of the top area of the housing unit rear wall must be removed for installation.

 The hob must be installed such that the drip tray and the cleaning flap are easily accessible and can be removed for cleaning.

Installation

② The air duct is laid behind the housing unit rear wall. The rear wall must be removable for maintenance purposes.

② The minimum plinth height of the KMDA 7676 FL-U is:

- Extraction mode: no minimum plinth height required
- Guided recirculation mode: 100 mm
- Plug&Play mode: 25 mm

② The minimum plinth height is:

- Extraction mode: no minimum plinth height required
- Guided recirculation mode: 100 mm
- Plug & Play mode: 25 mm

② The exhaust air drawn into the vapour extraction may only be routed through the base unit and back into the room in Plug&Play mode. In extraction mode and in guided recirculation mode, the exhaust air must be routed outside through ducting (extraction mode) or back into the room through the recirculation box (guided recirculation mode).

② Remember to maintain the minimum safety distances.

Additional safety notes for extraction mode

② The appliance must not be connected to a chimney or flue which is in use. Neither should it be connected to ducting which ventilates rooms with fireplaces.

② If exhaust air is to be extracted into a chimney or ventilation duct no longer used for other purposes, seek professional advice.

② Exhaust ducting must be of non-inflammable material. Suitable material is available from Miele specialist dealers or the Miele Spares Dept.

Additional safety notes for Plug & Play mode

U value

Plug&Play operation is possible in younger or renovated buildings. If the adjacent wall or the floor is in contact with the ground or the outside air, it must have a heat transfer coefficient (U value) of $\leq 0.5 \text{ W}/(\text{m}^2\text{K})$.

Material	Material thickness	U value _(as of 1995)
Solid wall <small>(vertical coring brick, floating brick or comparable porous or highly perforated materials)</small>	$\geq 30 \text{ cm}$	0.5
Solid timber wall <small>(e.g. log cabin/prefabricated house). Timber frame or timber panel wall with insulating filling</small>	—	0.4
Passive house <small>(KfW 55, 40, 40 Plus)</small>	—	0.15–0.2

The U values for other materials can be found on the websites of the German Federal Ministry for Economic Affairs and Climate Action and the German Federal Ministry of the Interior and Community.

If you have any other questions about your building, please contact a construction expert or energy adviser.

② The cross-section of the ventilation opening must be at least 425 cm^2 .

If ventilation grilles are to be inserted into the ventilation gaps, the ventilation gaps must be larger than 425 cm^2 . The unobstructed airflow of 425 cm^2 is calculated by adding up the total area of ventilation openings in the grilles.

The ventilation gaps must not be covered or blocked in any way. They must also be regularly dusted.

② The Plug&Play adapter included with the hob is required for operation in Plug&Play mode.

② A template is required when installing the hob.

Installation

 Risk of damage to the refrigeration appliance caused by vapours.

Vapours from the hob behind the refrigeration appliance can damage the refrigeration appliance.

Do not install appliances that discharge air or vapours directly behind the refrigeration appliance. Provide a separate air guide or install a partition wall between the appliances.

Additional safety notes for surface-mounted installation

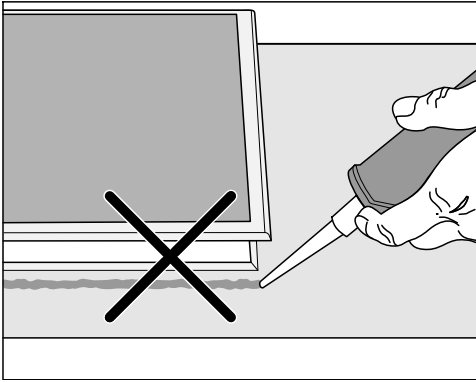

⚠ Damage caused by incorrect installation.

Using sealant under the hob could result in damage to the hob and the worktop if the hob ever needs to be removed.

Do not use sealant between the hob and the worktop. The sealing strip under the edge of the hob provides a sufficient seal for the worktop.

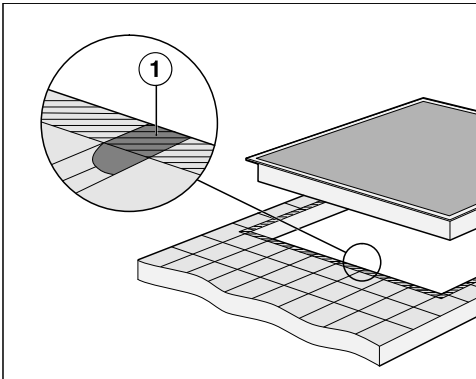

② Grout lines ① and the hatched area underneath the hob frame must be smooth and even. If they are not, the hob will not sit flush with the worktop and the sealing strip underneath the hob will not provide a good seal between the hob and the worktop.

Additional safety notes for flush-fit installation

⚠ Damage caused by using an unsuitable sealant.

Unsuitable sealant can damage natural stone.

For natural stone worktops and natural stone tiles, only use silicone sealant that is temperature-resistant (min. 160 °C) and specially formulated for natural stone. Follow the manufacturer's instructions.

② The internal width of the base unit underneath the appliance must be at least as wide as the inner worktop cut-out so that the hob is easily accessible from below after installation and the casing can be removed for maintenance. If the underside of the hob is not freely accessible after installation, any sealant must be removed to enable the hob to be lifted out.

Installation

❓ A flush-fit hob is suitable only for installation in natural stone (granite, marble), solid wood and tiled worktops. When using a worktop made from any other material, please check first with the worktop manufacturer that the material is suitable for installing a flush-fit hob.

- Natural stone worktops: the hob is set directly in the cut-out.
- Solid wood worktops, tiled worktops: the hob is secured inside the cut-out with wooden battens. The battens must be provided on site and are not included in the scope of delivery.

- The safety distance specified by the manufacturer of the cooker hood must be maintained.
- When two or more appliances which have different safety distances are installed together below a cooker hood, the greatest specified safety distance must be maintained.

If combustible objects are installed above the hob (e.g. cabinets, utensil rail, etc.), a minimum safety distance of 500 mm must be maintained.

Safety distances

Safety distance above the hob

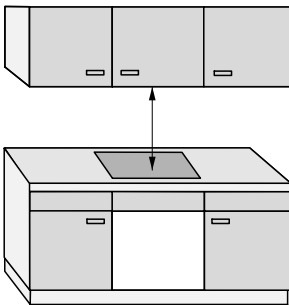

The following must be ensured between the hob and the cooker hood above it:

Safety distance behind and to the side of the hob

The minimum safety distances shown below must be maintained between the appliance and a tall unit or wall:

- Between the **back** ① of the worktop cut-out and the rear edge of the worktop:

50 mm

and

- On the **right side** ② between the worktop cut-out and the closest adjacent piece of furniture (e.g. tall unit) or a room wall:

50 mm and on the opposite side a minimum safety distance of 200 mm

or

- On the **left side** ③ between the worktop cut-out and the closest adjacent piece of furniture (e.g. tall unit) or a room wall:

50 mm and on the opposite side a minimum safety distance of 200 mm

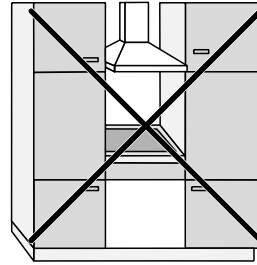

Not permitted

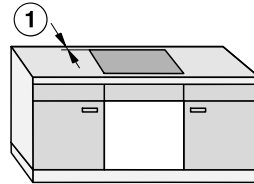
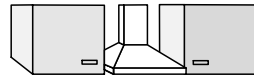

Highly recommended

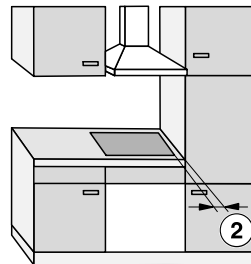

Not recommended

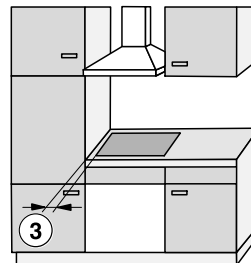

Not recommended

Installation

Minimum safety distance from the niche cladding

If niche cladding is installed, a minimum safety distance must be maintained between the worktop cut-out and the cladding. High temperatures can alter or damage these materials.

Flush-fit installation

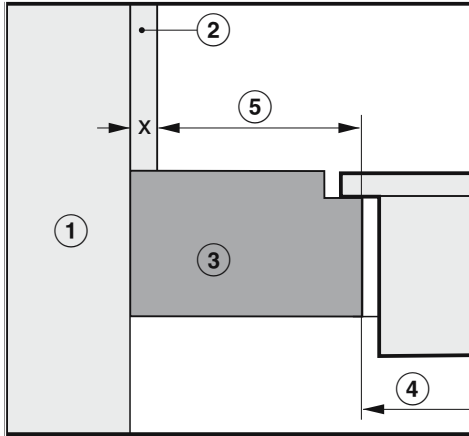

Surface-mounted installation

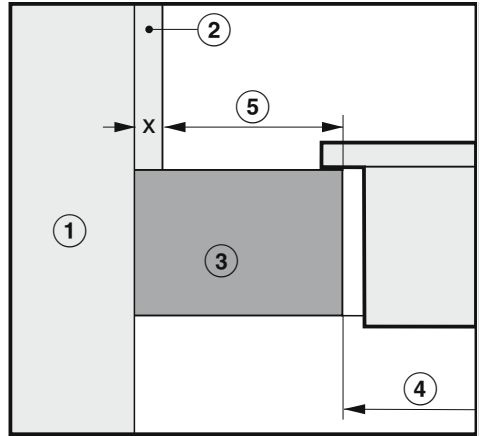

- ① Masonry
- ② Dimension x = thickness of the niche cladding material
- ③ Worktop
- ④ Worktop cut-out
- ⑤ Minimum safety distance to
 - combustible** materials (e.g. wood)
 - non-combustible** materials (e.g. metal, natural stone, ceramic tiles)

Material	Side		Opposite side	
	Combustible	Non-combustible	Combustible	Non-combustible
Back	50 mm	50 mm – dimension x	–	–
Right	50 mm	50 mm – dimension x	200 mm	200 mm – dimension x
Left	50 mm	50 mm – dimension x	200 mm	200 mm – dimension x

Example: 15 mm thick non-combustible niche cladding
50 mm minus 15 mm = minimum safety distance of 35 mm

Operating options

	Extraction mode	Guided recirculation mode	Plug & Play mode
KMDA 7676 FL-A	✓	●	●
KMDA 7676 FL-U	●	✓	✓✓

✓✓ Possible

✓ Possible – additional accessories required

● Setting has to be adjusted – additional accessories required

Installation examples

Guided recirculation mode

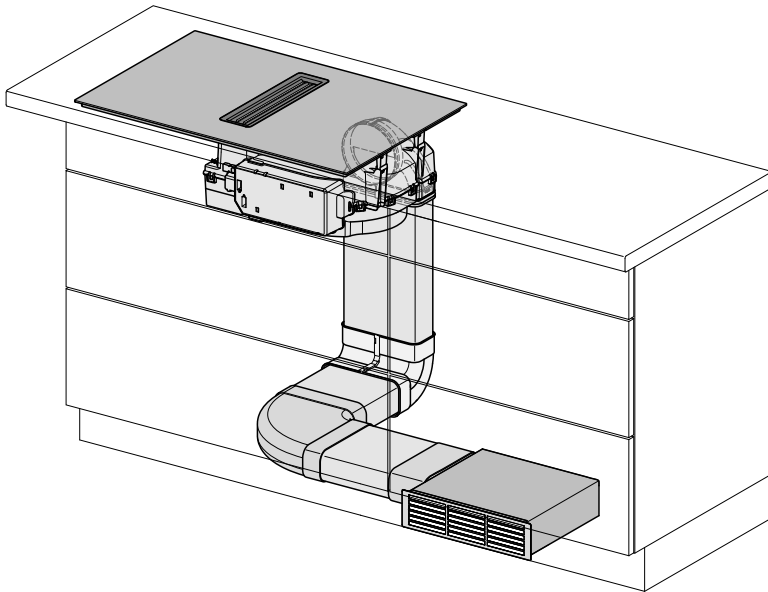

Installation

Extraction mode

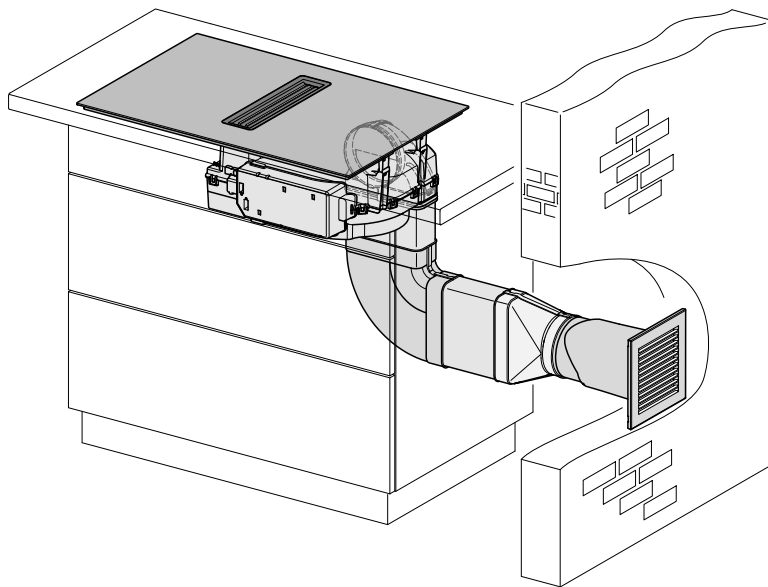

Plug & Play mode

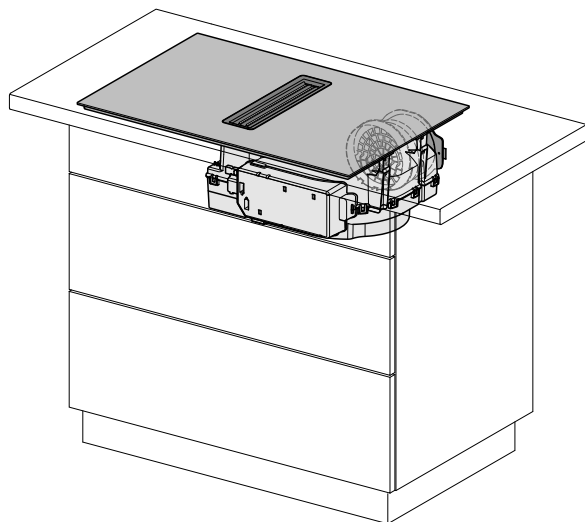

Plug & Play adapter dimensions (KMDA 7676 FL-U only)

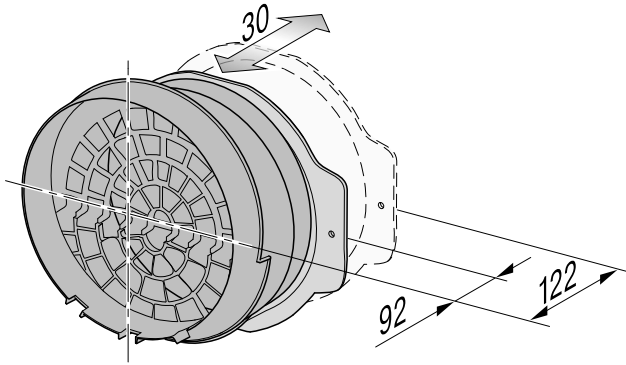

Extraction and guided recirculation mode

Worktop depth 600mm

KMDA 7676 FL-A, KMDA 7676 FL-U

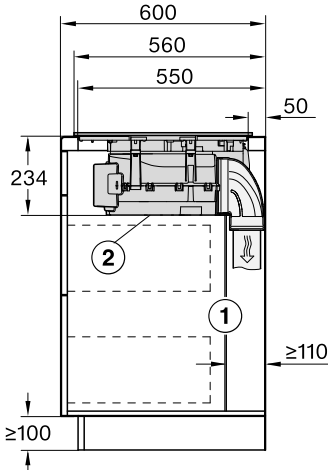

All dimensions are given in mm.

- ① For maintenance work it must be possible to remove the rear cabinet wall. The cabinet wall and an adjoining room wall or a piece of furniture must be at least 110 mm apart to ensure sufficient room for the ducting.
- ② The removable drip tray and the cleaning flap(s) must be accessible after installation.

Worktop depth greater than 600mm

KMDA 7676 FL-A, KMDA 7676 FL-U

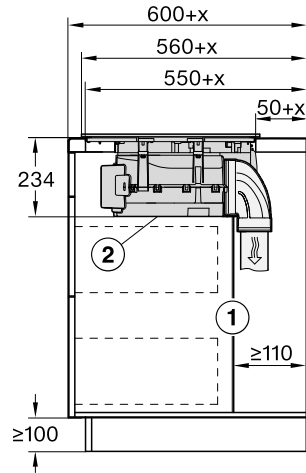

All dimensions are given in mm.

- ① For maintenance work it must be possible to remove the rear cabinet wall. The cabinet wall and an adjoining room wall or a piece of furniture must be at least 110 mm apart to ensure sufficient room for the ducting.
 - ② The removable drip tray and the cleaning flap(s) must be accessible after installation.
- x Dimension of which the worktop is deeper than 600 mm.

Installation

Plug&Play mode

Worktop depth 600mm

KMDA 7676 FL-U

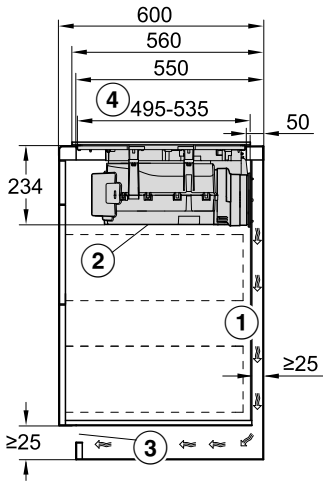

All dimensions are given in mm.

- ① The housing unit wall and an adjoining room wall or a piece of furniture must be at least 25 mm apart to ensure sufficient room for the exhaust air ducting.
- ② The removable drip tray and the cleaning flap(s) must be accessible after installation.
- ③ The cross-section of the ventilation opening must be at least 425 cm².
- ④ Distance from front of casing to end of Plug & Play adapter

Worktop depth greater than 600mm

KMDA 7676 FL-U

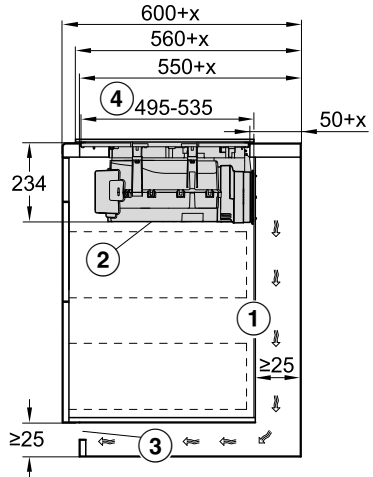

All dimensions are given in mm.

- ① The housing unit wall and an adjoining room wall or a piece of furniture must be at least 25 mm apart to ensure sufficient room for the exhaust air ducting. If the housing unit rear wall is > 555 mm away from the front of the worktop, the Plug&Play adapter must be combined with an expansion set from Miele.
 - ② The removable drip tray and the cleaning flap(s) must be accessible after installation.
 - ③ The cross-section of the ventilation opening must be at least 425 cm².
 - ④ Distance from front of casing to end of Plug & Play adapter
- x Dimension of which the worktop is deeper than 600 mm.

Installation dimensions for flush-fit installation

KMDA 7676 FL-A, KMDA 7676 FL-U

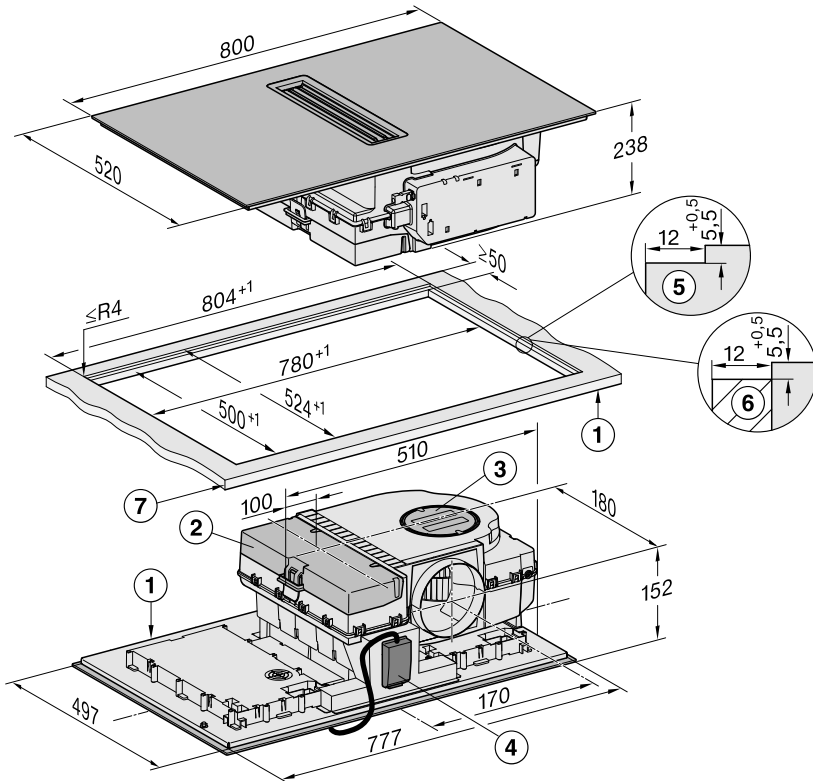

All dimensions are given in mm.

- ① Front
- ② Removable drip tray
- ③ Cleaning flap
- ④ Mains connection box with mains connection cable
Mains connection cable L = 1440 mm
- ⑤ Stepped cut-out, natural stone worktop
- ⑥ Wooden batten 12 mm (accessories not included)
- ⑦ Worktop thickness
Extraction and guided recirculation mode: ≥ 10 mm
Plug&Play mode: ≥ 10 mm– ≤ 40 mm

Installation

Extraction and guided recirculation mode

Worktop depth 600mm

KMDA 7676 FL-A, KMDA 7676 FL-U

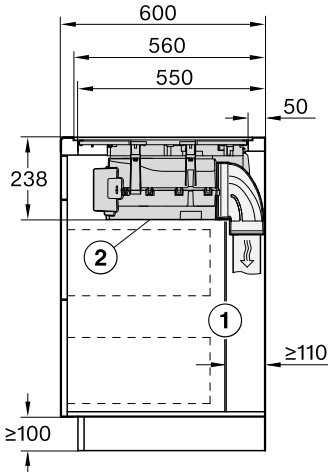

All dimensions are given in mm.

- ① For maintenance work it must be possible to remove the rear cabinet wall. The cabinet wall and an adjoining room wall or a piece of furniture must be at least 110 mm apart to ensure sufficient room for the ducting.
- ② The removable drip tray and the cleaning flap(s) must be accessible after installation.

Worktop depth greater than 600mm

KMDA 7676 FL-A, KMDA 7676 FL-U

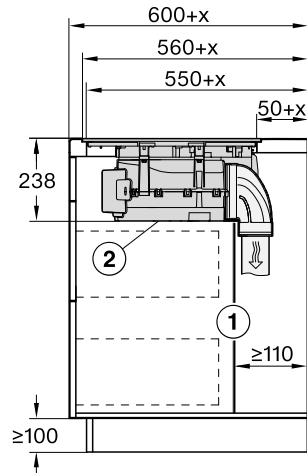

All dimensions are given in mm.

- ① For maintenance work it must be possible to remove the rear cabinet wall. The cabinet wall and an adjoining room wall or a piece of furniture must be at least 110 mm apart to ensure sufficient room for the ducting.
 - ② The removable drip tray and the cleaning flap(s) must be accessible after installation.
- x Dimension of which the worktop is deeper than 600 mm.

Plug&Play mode

Worktop depth 600mm

KMDA 7676 FL-U

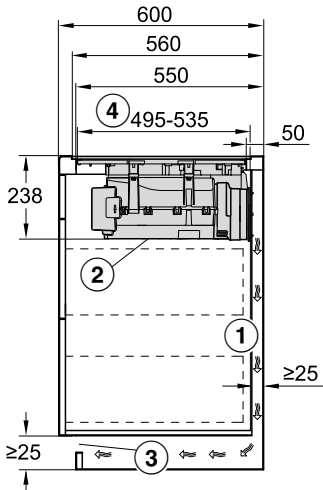

All dimensions are given in mm.

- ① The housing unit wall and an adjoining room wall or a piece of furniture must be at least 25 mm apart to ensure sufficient room for the exhaust air ducting.
- ② The removable drip tray and the cleaning flap(s) must be accessible after installation.
- ③ The cross-section of the ventilation opening must be at least 425 cm².
- ④ Distance from front of casing to end of Plug & Play adapter

Worktop depth greater than 600mm

KMDA 7676 FL-U

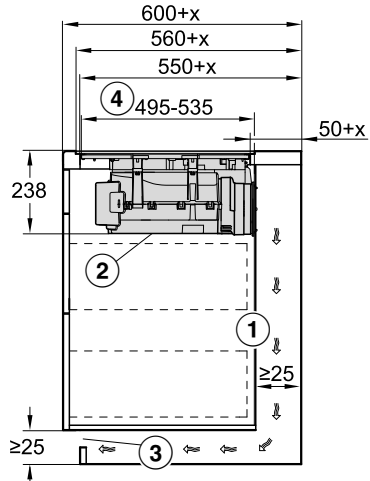

All dimensions are given in mm.

- ① The housing unit wall and an adjoining room wall or a piece of furniture must be at least 25 mm apart to ensure sufficient room for the exhaust air ducting. If the housing unit rear wall is > 555 mm away from the front of the worktop, the Plug&Play adapter must be combined with an expansion set from Miele.
- ② The removable drip tray and the cleaning flap(s) must be accessible after installation.
- ③ The cross-section of the ventilation opening must be at least 425 cm².
- ④ Distance from front of casing to end of Plug & Play adapter
- x Dimension of which the worktop is deeper than 600 mm.

Installation

Connection to window contact, if required

 The window contact connection is live.

Danger of electric shock.

Disconnect the hob from the mains power supply before connecting the switching system.

The mains connection cable for the switching system must only be connected by a suitably qualified electrician.

The mains connection cable for the switching system must comply with type H03VV-F 2 x 0.75 mm² and must not exceed 2.0 m in length.

The switching system must be equipped with a potential-free contact suitable for 230 V, 1 A. The cooker hood is switched off when the switch is open.

Only use DIBt-approved and tested radio switching systems (e.g. window contact switches, pressure switches) and have them approved by authorised specialists (e.g. building regulations inspector).

You will need the appropriate external switching system documents to safely connect and operate the switch.

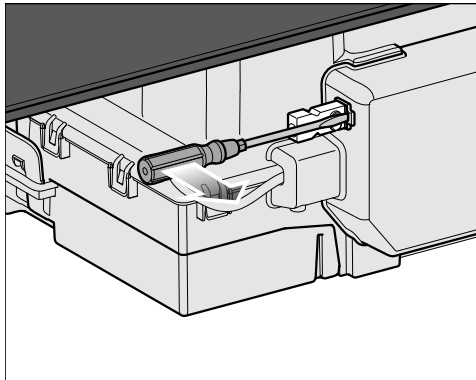

- Loosen the retainer and pull the plug out.

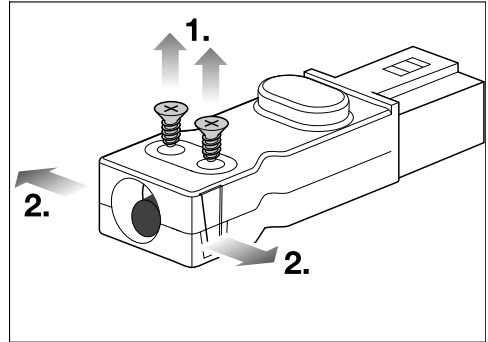

- Loosen the strain relief screws ① and unlock the casing on both sides ②.
- Open the casing.
- Remove the stopper.

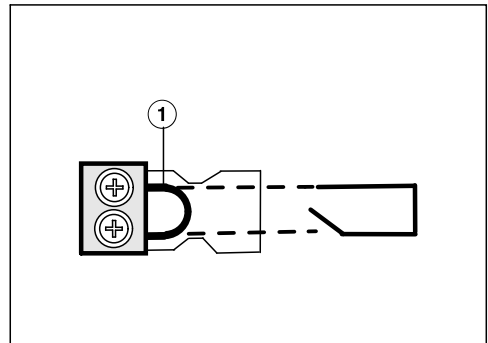

- Exchange the bridge ① for the mains connection cable of the switching system.
- Close the casing.
- Tighten the strain relief screw.
- Reinsert the plug.

Installing a surface-mounted hob with extraction and guided recirculation mode

Preparing the worktop for surface-mounted installation in extraction and guided recirculation mode

- Remember to maintain the minimum safety distances.
- Create the worktop cut-out.
- Wooden worktops:
Seal any cut surfaces with a special varnish, silicone sealant or resin to prevent the wood from swelling as a result of moisture ingress. The sealant must be heat-resistant.

Make sure that the sealant does not come into contact with the surface of the worktop.

Installing a surface-mounted hob with extraction and guided recirculation mode

- Attach the sealing strip provided underneath the edge of the hob. Do not apply the sealing strip under tension.
- Feed the mains connection cable for the hob down through the worktop cut-out.
- Place the hob centrally in the cut-out. When doing this, make sure that the seal of the appliance sits flush with the worktop on all sides. This is important to ensure effective sealing all round.
- If the seal does not sit flush with the worktop in the corners, the corner radius ($\leq R4$) can be carefully cut to fit using a jigsaw.
- Connect the hob to the mains power supply.
- Check that the hob is working.

Installing a surface-mounted hob with Plug & Play

Preparing the worktop for surface-mounted installation with Plug & Play

- Remember to maintain the minimum safety distances.
- Create the worktop cut-out.
- Cut the top of the drilling template to the thickness of your worktop. Depending on the installation depth, place the correct drilling template on top of the housing unit rear wall. Use the drilling template to create a cut-out for the Plug & Play adapter.

Installation

Drilling template number	Adapter position	Installation distance (vertical) between the top of the appliance and the lowest point of the Plug & Play adapter
2	2	238 mm ¹
3a	3	248 mm ²

¹ The template is supplied with the appliance.

² The templates can be found on the Miele homepage.

- If you do not have a drilling template, see “Installation – Rear panel cut-out without drilling template”.
- **Wooden worktops:**
Seal any cut surfaces with a special varnish, silicone sealant or resin to prevent the wood from swelling as a result of moisture ingress. The sealant must be heat-resistant.

Make sure that the sealant does not come into contact with the surface of the worktop.

Installing a surface-mounted hob with Plug & Play

- Attach the sealing strip provided underneath the edge of the hob. Do not apply the sealing strip under tension.

The Plug & Play adapter may break off.
When placing the hob on the worktop, make sure that it is not placed on top of the Plug & Play adapter.

- Connect the Plug & Play adapter to the hob and set the adapter position.
- Feed the mains connection cable for the hob down through the worktop cut-out.
- Remove the protective foil from the adhesive tape at the end of the Plug & Play adapter.
- Place the hob centrally in the cut-out. When doing this, make sure that the seal of the appliance sits flush with the worktop on all sides. This is important to ensure effective sealing all round.
- If the seal does not sit flush with the worktop in the corners, the corner radius ($\leq R4$) can be carefully cut to fit using a jigsaw.
- Align the Plug & Play adapter with the predrilled hole. Press the adapter onto the rear panel until it sticks in place.
- Connect the hob to the mains power supply.
- Check that the hob is working.

Installing a flush-fit hob with extraction and guided recirculation mode

Preparing the worktop for flush-fit installation in extraction and guided recirculation mode

- Remember to maintain the minimum safety distances.

- Create the worktop cut-out.
- Solid wood and tiled worktops:

Secure the wooden frame 5,5 mm below the top edge of the worktop.

Installing a flush-fit hob with extraction and guided recirculation mode

- Attach the sealing strip provided underneath the edge of the hob. Do not apply the sealing strip under tension.
- Feed the mains connection cable for the hob down through the worktop cut-out.

The gap between the ceramic surface and the worktop must be at least 2 mm wide. This is required so that the hob can be sealed.

- Centre the hob in the cut-out.
- Connect the hob to the mains power supply.
- Check that the hob is working.
- Seal the gap between the hob and worktop with a silicone sealant that is heat-resistant to at least 160 °C.

Installing a flush-fit hob with Plug & Play

Preparing the worktop for flush-fit installation with Plug & Play

- Remember to maintain the minimum safety distances.
- Create the worktop cut-out.
- Cut the top of the drilling template to the thickness of your worktop. Depending on the installation depth, place the correct drilling template on top of the housing unit rear wall. Use the drilling template to create a cut-out for the Plug & Play adapter.

Drilling template number	Adapter position	Installation distance (vertical) between the top of the appliance and the lowest point of the Plug & Play adapter
1	1	238 mm ¹
3b	3	248 mm ²

¹ The template is supplied with the appliance.

² The templates can be found on the Miele homepage.

- If you do not have a drilling template, see “Installation – Rear panel cut-out without drilling template”.
- Solid wood and tiled worktops:

Secure the wooden frame 5,5 mm below the top edge of the worktop.

Installation

Installing a flush-fit hob with Plug & Play

- Attach the sealing strip provided underneath the edge of the hob. Do not apply the sealing strip under tension.

The Plug & Play adapter may break off.
When placing the hob on the worktop, make sure that it is not placed on top of the Plug & Play adapter.

- Connect the Plug & Play adapter to the hob and set the adapter position.
- Feed the mains connection cable for the hob down through the worktop cut-out.
- Plug & Play mode: remove the protective foil from the adhesive tape at the end of the Plug & Play adapter.
- Centre the hob in the cut-out.

The gap between the ceramic glass surface and the worktop must be at least 2 mm wide.
This is required so that the hob can be sealed.

- Align the Plug & Play adapter with the predrilled hole. Press the adapter onto the rear panel until it sticks in place.
- Connect the hob to the mains power supply.
- Check that the hob is working.
- Seal the gap between the hob and worktop with a silicone sealant that is heat-resistant to at least 160 °C.

Installing exhaust ducting

 If the vapour extraction is used at the same time as a heating appliance that relies on oxygen from the same room, there is a risk of toxic fumes. It is essential that the “Warnings and safety notes” are observed. The vapour extraction should be installed according to local and national building regulations. Seek approval from the building regulations inspector where necessary.

Remember that any constriction of the air flow will reduce air throughput and increase operating noise.

The vapour extraction has an exhaust duct with the following dimensions: \varnothing 150 mm.

- Only use smooth pipes or flexible exhaust hoses made from non-flammable materials for exhaust ducting.
- To achieve the most efficient air throughput with the lowest noise levels, please note the following:
 - The cross-section of the exhaust ducting must not be smaller than the cross-section of the exhaust duct (see the appliance dimensions).
 - The ducting should be as short and straight as possible.
 - Only use wide radius bends.
 - The exhaust ducting must not be kinked or compressed.
 - Ensure that all connections are strong and airtight.

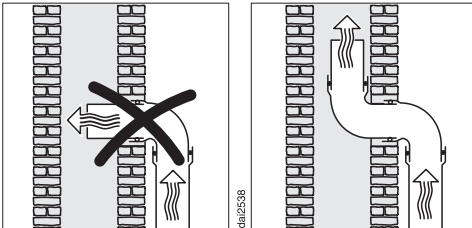

- If the exhaust air is to be ducted into a flue, the ducting must be directed in the flow direction of the flue.

- If ducting is to be laid horizontally it must be laid with a downwards sloping gradient. This is to ensure that condensate cannot drain back into the fan.
- If the ducting is to run through cool rooms, ceiling space, etc., there may be great variations in temperature between the different areas. The problem of condensation will need to be addressed. The ducting will need to be suitably insulated.

Installation

Rear wall cut-out without drilling template

Creating the rear panel cut-out with surface-mounted installation and an installation distance (vertical) between the top of the appliance and the lowest point of the Plug & Play adapter of 238mm

Ideally, the drilling template supplied with the appliance should be used. The following instructions should only be used if the drilling template is not available.

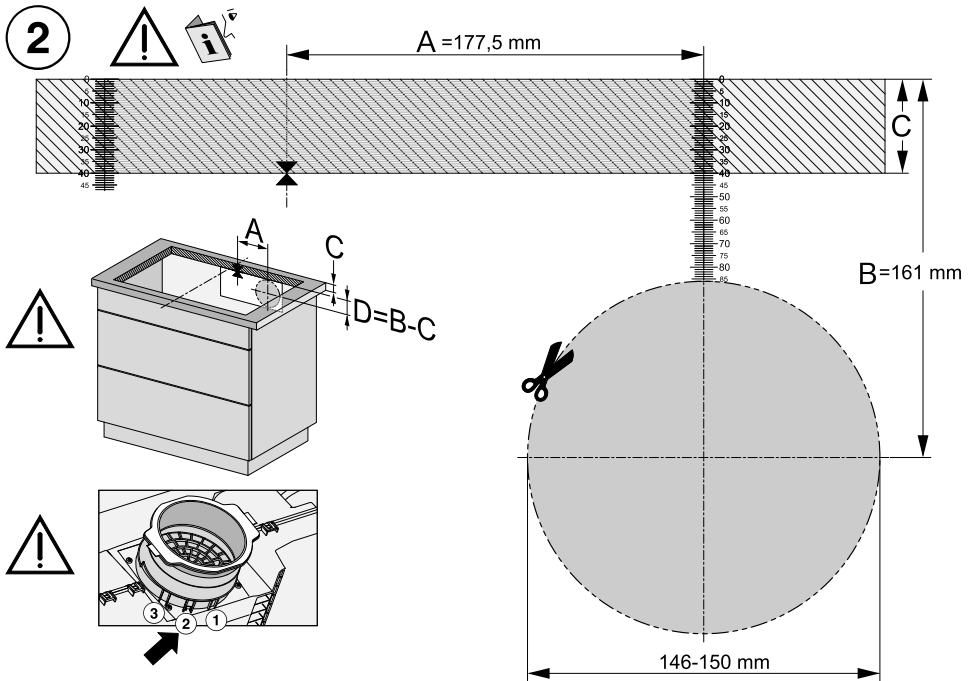

Image of drilling template, side 2. Not to scale.

- Measure the thickness of the worktop (C).
- Locate the centre of the long axis of the cut-out.
- Mark the point that is 177,5 mm (A) to the right of the midpoint.
- Mark the point (D) that is $(B [161 \text{ mm}] - C [\text{thickness of the worktop}])$ below the right end of distance A.
- Create a cut-out around the area using the following measurements: $\text{Ø } 146-150 \text{ mm}$.
- Plug & Play mode only: engage the Plug & Play adapter in position 2.

Creating the rear panel cut-out with flush-fit installation and an installation distance (vertical) between the top of the appliance and the lowest point of the Plug & Play adapter of 238mm

Ideally, the drilling template supplied with the appliance should be used. The following instructions should only be used if the drilling template is not available.

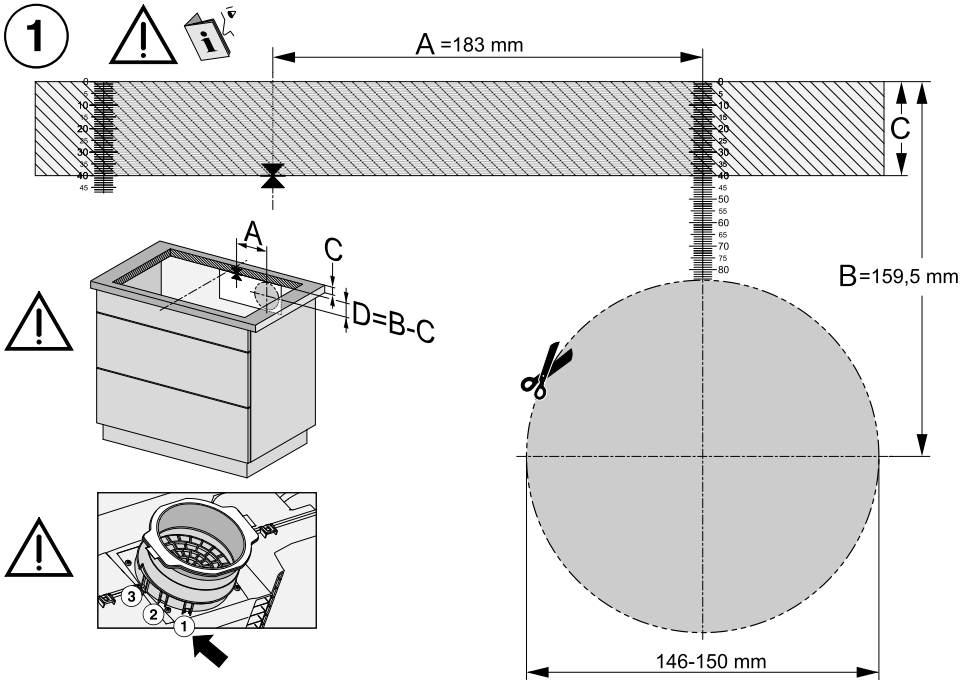

Image of drilling template, side 1. Not to scale.

- Measure the thickness of the worktop (C).
- Locate the centre of the long axis of the cut-out.
- Mark the point that is 183 mm (A) to the right of the midpoint.
- Mark the point (D) that is $(B [159,5 \text{ mm}] - C [\text{thickness of the worktop}])$ below the right end of distance A.
- Create a cut-out around the area using the following measurements: $\varnothing 146-150 \text{ mm}$.
- Plug & Play mode only: engage the Plug & Play adapter in position 1.

Installation

Creating the rear panel cut-out with surface-mounted installation and an installation distance (vertical) between the top of the appliance and the lowest point of the Plug & Play adapter of 248mm

Ideally, the drilling template supplied with the appliance should be used. The following instructions should only be used if the drilling template is not available.

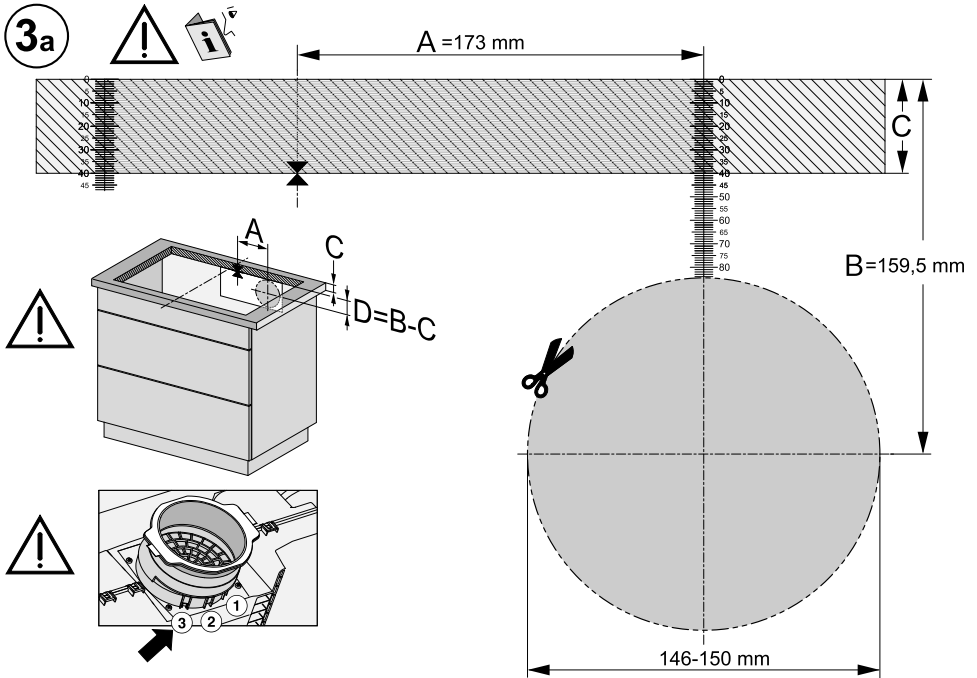

View of the drilling template side 3a. Not to scale.

- Measure the thickness of the worktop (C).
- Locate the centre of the long axis of the cut-out.
- Mark the point that is 173 mm (A) to the right of the midpoint.
- Mark the point (D) that is $(B [159,5 \text{ mm}] - C [\text{thickness of the worktop}])$ below the right end of distance A.
- Create a cut-out around the area using the following measurements: $\varnothing 146\text{--}150 \text{ mm}$.
- Plug & Play mode only: engage the Plug & Play adapter in position 3.

Creating the rear panel cut-out with flush-fit installation and an installation distance (vertical) between the top of the appliance and the lowest point of the Plug & Play adapter of 248mm

Ideally, the drilling template supplied with the appliance should be used. The following instructions should only be used if the drilling template is not available.

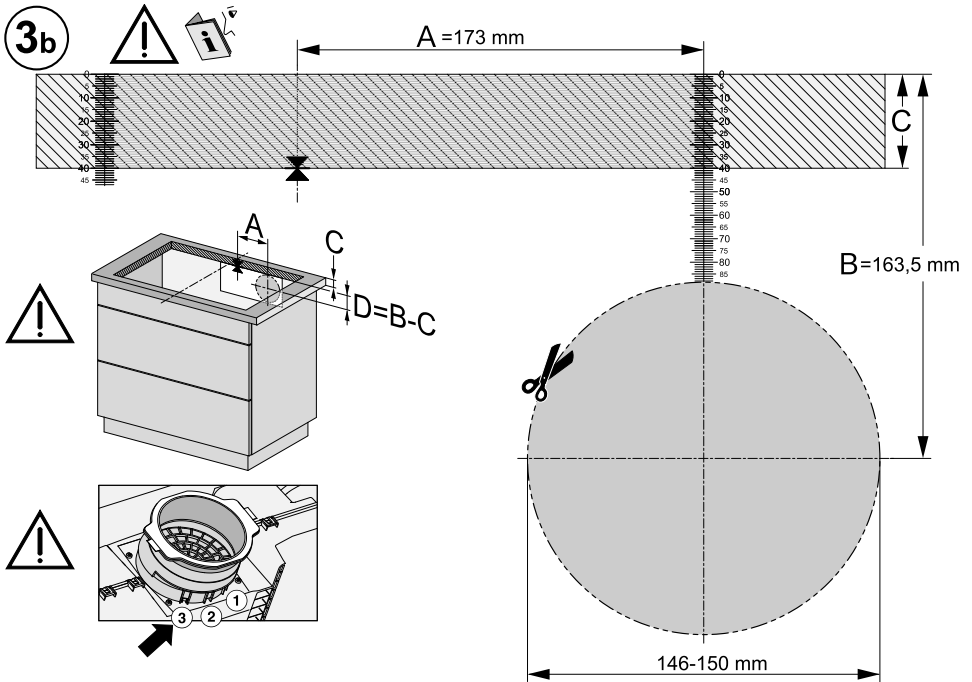

View of the drilling template side 3b. Not to scale.

- Measure the thickness of the worktop (C).
- Locate the centre of the long axis of the cut-out.
- Mark the point that is 173 mm (A) to the right of the midpoint.
- Mark the point (D) that is $(B [163,5 \text{ mm}] - C [\text{thickness of the worktop}])$ below the right end of distance A.
- Create a cut-out around the area using the following measurements: $\varnothing 146-150 \text{ mm}$.
- Plug & Play mode only: engage the Plug & Play adapter in position 3.

Installation

Electrical connection



Risk of damage from incorrect connection.

Unauthorised installation, maintenance and repairs can cause considerable danger for the user.

Miele cannot be held liable for damage or injury caused by unauthorised installation, maintenance or repair work, or by an inadequate or faulty on-site earthing system (e.g. electric shock).

This hob must be connected to the mains power supply by a qualified electrician.

The qualified electrician must be familiar with and comply with the national regulations and any additional regulations of the local electricity provider.

After installation, ensure that all electrical components are shielded and cannot be accessed by users.

Total power rating

See data plate

Connection data

The connection data is quoted on the data plate. Please ensure these match the household mains supply.

Please see wiring diagrams for connection. (N.B. This appliance is supplied single phase only in the UK / AUS / NZ).

Residual current device

For extra safety, it is advisable to protect the hob with a suitable residual current device (RCD) with a trip range of 30 mA.

Disconnecting devices

It must be possible to disconnect the hob from the mains at all poles using disconnecting devices. A contact distance of at least 3 mm must be observed in the switched-off state. The disconnecting devices include over-current protection devices and residual current protection devices.

Disconnecting from the mains



Risk of electric shock from mains voltage.

There is a risk of electric shock if the appliance is reconnected to the mains voltage supply during repair or service work.

After disconnection, ensure the appliance cannot be switched back on by mistake.

To disconnect the appliance from the mains power supply, do one of the following depending on installation:

Fine-wire fuses

- Completely remove the fuse links from the screw caps.

Automatic circuit breakers

- Press the test button (red) until the middle button (black) springs out.

Built-in circuit breakers

- For circuit breakers of at least type B or C, switch the lever from 1 (on) to 0 (off).

Residual current device

- Residual current device: switch the main switch from 1 (on) to 0 (off) or press the test button.

Mains connection cable

The hob must be connected to the electrical supply with a special connection cable, type H 05 VV-F (PVC insulated) with a suitable diameter.

Please see wiring diagrams for connection.

See the data plate on the hob for the correct voltage and rated load.

Replacing the mains connection cable

 Risk of electric shock. Incorrect connection to the power supply may result in an electric shock. The mains cable must only be replaced by a qualified electrician.

When replacing the mains cable only use cable type H 05 VV-F (PVC insulated) with a suitable cross section. A suitable connection cable is available to order from Miele.

Wiring diagram

Some connection methods are not permitted in all installation locations. Ensure compliance with national regulations and any additional regulations issued by the local electricity provider.

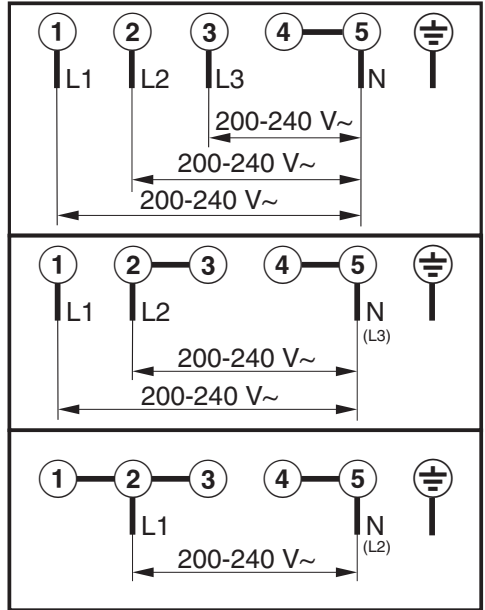

Familiarisation

Your hob

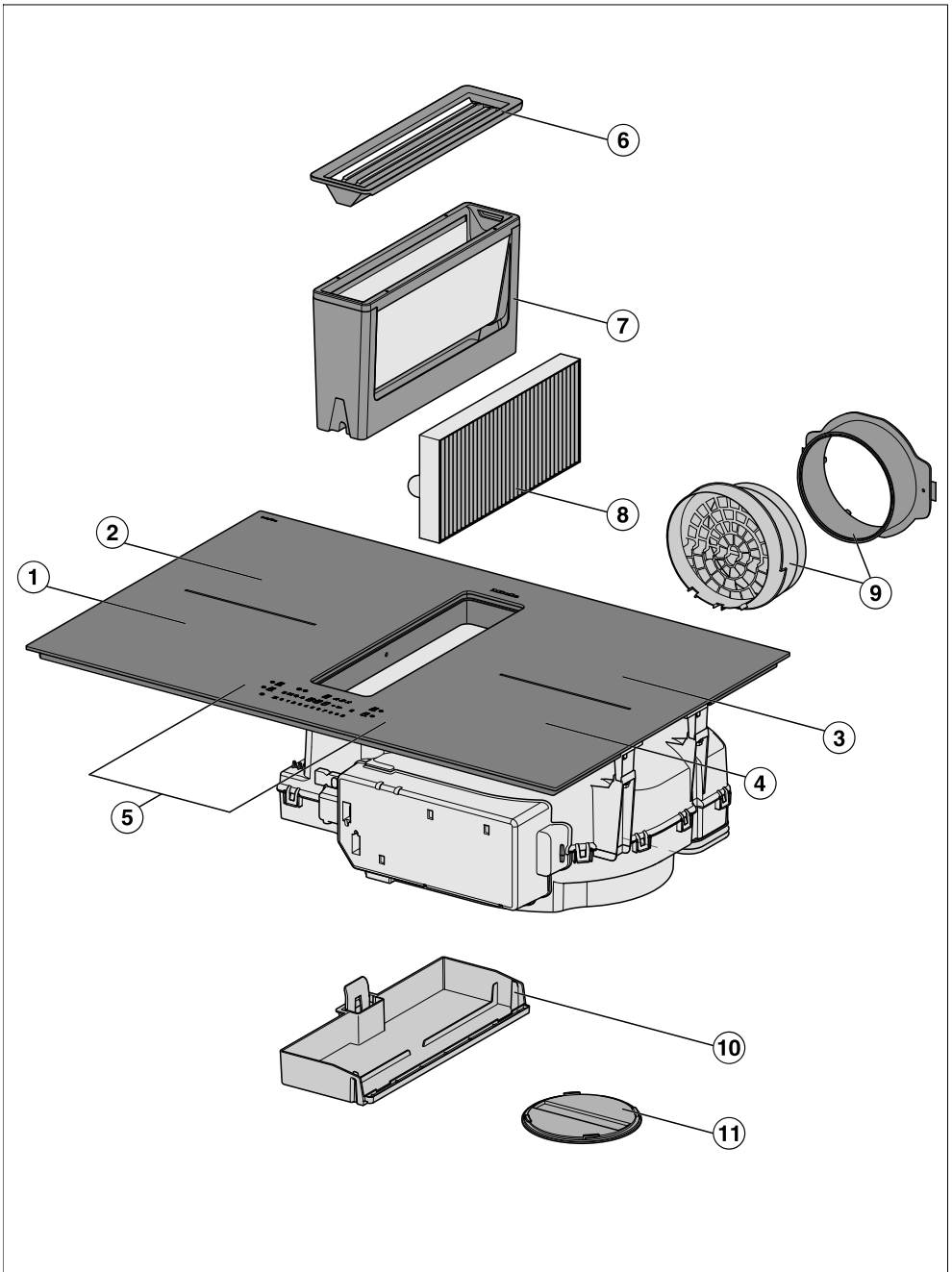

① PowerFlex cooking zone with TwinBooster

Familiarisation

- ② PowerFlex cooking zone with TwinBooster
can be combined with PowerFlex cooking zone ① to form PowerFlex XL cooking area
- ③ PowerFlex cooking zone with TwinBooster
can be combined with PowerFlex cooking zone ④ to form PowerFlex XL cooking area
- ④ PowerFlex cooking zone with TwinBooster
- ⑤ Controls and indicators
- ⑥ Cover grille
- ⑦ Grease filter
- ⑧ Charcoal filter
KMDA 7676 FL-U only
- ⑨ Plug&Play adapter
KMDA 7676 FL-U only
- ⑩ Removable drip tray
- ⑪ Cleaning flap

Features

Features will vary depending on model.

Scope of delivery

- Drilling template (only KMDA 7676 FL-U)
- Charcoal filter (only KMDA 7676 FL-U)
- Plug & Play adapter (only KMDA 7676 FL-U)
- Operating and installation instructions
- Mains connection cable
- Further accessories (depending on the model)

Drilling template

This accessory is supplied ex works with the following KMDAs:

KMDA 7676 FL-U

Drilling template printed on both sides, used to create the cut-out for the Plug & Play adapter with an installation distance (vertical) between the top of the appliance and the lowest point of the Plug & Play adapter of 238 mm.

Drilling templates for creating a cut-out for the Plug & Play adapter with an installation distance (vertical) between the top of the appliance and the lowest point of the Plug & Play adapter of 248 mm can be found on the Miele homepage.

Charcoal filter

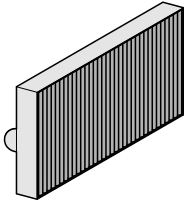

The charcoal filter DKF 35-P is included 1 times with the following KMDAs:
KMDA 7676 FL-U

Plug & Play adapter

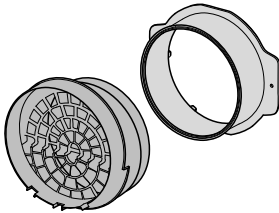

This accessory is supplied ex works with the following KMDAs:
KMDA 7676 FL-U

Optional accessories

Products specially tailored to your hob – such as cookware and cleaning agents – are available from the Miele online shop, Miele Customer Service or your Miele specialist dealer.

You can access the Miele online shop via the following QR code:





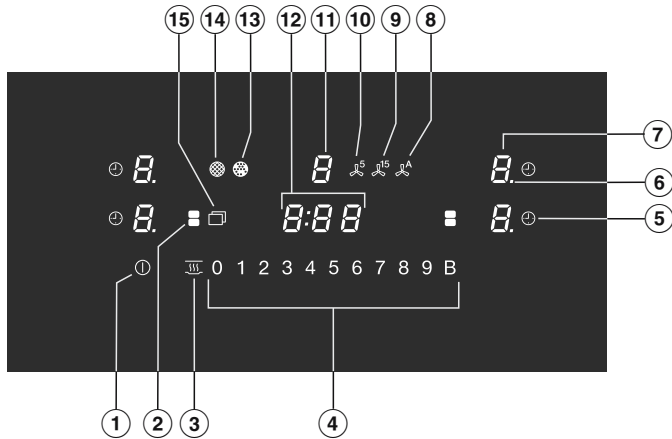

Controls and indicators



- ① On/Off ① sensor control
- ② PowerFlex XL ② sensor control
To link/unlink PowerFlex XL cooking zones manually
- ③ Keeping warm ③ sensor control
To activate/deactivate the Keeping warm special function
- ④ Numerical display
 - To set the power level
 - To set the times
- ⑤ Auto switch off ⑤ sensor control
Switches the cooking zones off automatically after a set period of time
Measures the time a cooking process takes
- ⑥ Power level display – intermediate levels
- ⑦ Cooking zone display

0	Cooking zone is ready for operation
1 to 9	Power level
⊞	Residual heat
⌘	Auto heat-up
⊘	Cookware missing or unsuitable
,	TwinBooster level 1
„	TwinBooster level 2
h	Keeping warm

- ⑧ *Con@ctivity*  sensor control
For activating/deactivating the Con@ctivity function of the built-in cooker hood
- ⑨ *15 minute run-on*  sensor control
- ⑩ *5 minute run-on*  sensor control
- ⑪ Vapour extraction display

 The cooker hood is ready for operation

 Power level
(can be changed to 9 levels)

 Booster is activated

- ⑫ Timer display

 Time

 System lock/safety lock is activated.

 Demo mode is active.

- ⑬ *Charcoal filter indicator* 
Charcoal filter(s) must be replaced

- ⑭ *Grease filter indicator* 
Grease filter must be cleaned

- ⑮ *Menu*  sensor control to display the following sensor controls:

 *Wipe protection* sensor control to lock the control elements and indicators for 20 seconds

 *Minute minder* sensor control: an alarm for activities that are independent of the hob

 *Input* sensor control
– To adjust the settings
– To adjust the times

 *Stop&Go*
sensor control to stop/start a cooking process in progress

Familiarisation

Cooking zone data

Cooking zone	Size in cm ¹		Max. rating in watts for 230V ²	Linked cooking zone ³	
	∅				
①	15–23	15 x 15 – 23 x 23	Normal TwinBooster, level 1 TwinBooster, level 2	2100 3000 3650	③
②	15–23	15 x 15 – 23 x 23	Normal TwinBooster, level 1 TwinBooster, level 2	2100 3000 3650	④
③	15–23	15 x 15 – 23 x 23	Normal TwinBooster, level 1 TwinBooster, level 2	2100 3000 3650	①
④	15–23	15 x 15 – 23 x 23	Normal TwinBooster, level 1 TwinBooster, level 2	2100 3000 3650	②
① + ② ③ + ④	–	15 x 25 – 23 x 46	Normal TwinBooster, level 1 TwinBooster, level 2	3400 4800 7300	-
			Total	7300	

¹ Cookware with a base diameter or surface (width x depth) within the given range may be used.

² The rating given may vary depending on the size and material of the cookware used.

³ The cooking zone is linked to this cooking zone electrically so that the rating can be increased.

Power management

Total permitted power consumption

The hob has a maximum total permitted power consumption which cannot be exceeded for safety reasons. You can reduce the maximum total permitted power consumption.

The higher the total permitted power consumption of the hob, the more power levels/special functions can be used on all cooking zones at the same time.

If the set power levels/special functions require more power than can be provided in accordance with the total permitted power consumption, the hob will distribute the maximum permitted power between the cooking zones.

Effects of power distribution

If a cooking zone gives power to another zone, this can have the following effects on the zone giving the power:

- The power level is reduced.
- Auto heat-up is deactivated. Cooking continues at the set level. If the power is not sufficient, the power level will be reduced again.
- The Booster function is deactivated.
- The cooking zone is switched off.

When the cooking zone stops transferring power to another zone, the power level can be increased again.

Tip: If you wish to cook a large quantity of food on one cooking zone, switch the other cooking zones to lower power levels.

Operation

Hob when switched off

Only the printed symbol for the On/Off ① *On/Off* sensor control is visible when the hob is switched off. More sensor controls light up when the hob is switched on.

Controls

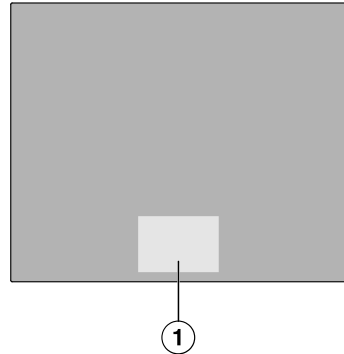

- ① Area for sensor controls and displays

This ceramic glass hob is equipped with sensor controls which react to finger contact. Each time a sensor control is activated, a buzzer sounds.

For safety reasons, the On/Off ① *On/Off* sensor control needs to be touched for a little longer than the other sensors in order to switch the appliance on.

Selecting a cooking zone

If you want to configure settings for a cooking zone, the cooking zone must be selected first. To select a cooking zone, touch the corresponding cooking zone display. After you touch the cooking zone display, it lights up brightly. When the cooking zone display appears bright, the cooking zone is selected and you

Familiarisation

can configure settings for the cooking zone. If cookware is detected on the other cooking zones, the other cooking zone indicators light up dimly. **Exception:** if only one of the cooking zones is in operation, you can configure settings without selecting the cooking zone.

Kitchen ventilation

Ensure that the kitchen is well ventilated when operating the cooker hood.

In extraction mode, the efficiency of the cooker hood is improved by the incoming air.

In recirculation mode, the moisture produced during cooking remains in the kitchen. Ventilation helps to dissipate moisture.

Components

Grease filter

The re-usable metal grease filters in the appliance remove solid particles (grease, dust, etc.) from the kitchen vapours, preventing soiling of the cooker hood.

Charcoal filter

With recirculation mode and Plug & Play recirculation mode, a charcoal filter must be fitted in addition to the grease filters. The charcoal filter is designed to absorb cooking odours.

A charcoal filter (DKF 35-P) is supplied as standard with the following KMDAs: KMDA 7676 FL-U

Charcoal filters are available as optional accessories. There are charcoal filters available

- that need to be replaced at the end of their operating time
- and others that can be reactivated.

Networking

Your hob is equipped with an integrated WiFi module. The hob can be connected to your home network or just to your Miele cooker hood. The WiFi module enables the Miele app to be used on a mobile device.

Once your hob has been connected via WiFi, the connection is automatically re-established every time it is switched on.

Make sure that your WiFi network signal is strong enough in the place where you intend to install your hob.

Connecting your hob to your WiFi network will increase energy consumption, even when the hob is switched off.

Smart Extras via the Miele app*

Networking via the Miele app gives you access to numerous Smart Extras, including:

- Access status information.
- Use additional helpful functions.
- Keep your hob up to date with the latest Miele developments via software updates (only possible via WiFi connection).

You can find more detailed information about Smart Extras on the Miele website, in the Apple App Store® or in the Google Play Store™.

*This is a separate digital offer from Miele & Cie. KG. The range of functions can vary depending on the model and the country. Acceptance of the Terms and Conditions and Privacy Policy for Miele digital products & services in the Miele app required. Miele reserves the right to change or discontinue the digital offer at any time.

Special functions

Permanent pan recognition

When you place cookware on a cooking zone, the numerical display for the cooking zone is activated automatically.

Pan size recognition

The size of the cookware is detected within a cooking zone. The release of energy is adapted to the size of the pan.

PowerFlexXL cooking area

A PowerFlex XL cooking area links together 2 PowerFlex cooking zones, making it possible to use larger cookware.

The PowerFlex cooking zones link automatically to form a PowerFlex XL cooking area when you place sufficiently large items of cookware on them. The PowerFlex cooking zones can also be linked manually.

Hob power levels

You can set the power for the cookware in levels from 1 to 9.

If you wish to fine-tune the power levels, you can activate intermediate levels via the settings.

Hob Booster

When the Booster function is activated, the power is boosted so that large quantities can be heated up quickly, e.g. when boiling water for cooking pasta.

Stop&Go

When Stop&Go is activated, all power levels are reduced to 1.

When the function is deactivated, the appliance switches back to the power level that was set last.

Tip: Use this special function if there is a danger of food boiling over.

Auto heat-up

When auto heat-up has been activated, the cooking zone switches on automatically at the highest setting (heat-up boost) and then switches to the power level (continued cooking setting) which you have previously selected.

Timers

The timer can be used for the following two functions:

- For setting the minute minder
- For automatically switching a cooking zone off

You can use the functions simultaneously.

Minute minder

You can set an alarm for activities that are independent of the hob.

Auto switch off

You can set a time after which a cooking zone will switch off automatically. This function can be used for all cooking zones at the same time.

System lock

If the system lock is activated, then the hob cannot be switched on.

Familiarisation

Lock

The safety lock is activated when the hob is switched on. When the lock is activated, the hob can be operated only under certain conditions.

Recall

If the hob is switched off by mistake during use, this function can be used to restore all settings. The hob must be switched on again within 10 seconds of being switched off.

Keeping warm

This special function enables food to be kept warm after it has finished cooking.

The maximum duration for keeping food warm is 2 hours.

Wipe protection

The hob sensor controls can be locked for 20 seconds to remove soiling, for example.

① *On/Off* is not locked.

Con@ctivity

The vapour extraction will switch itself on automatically if there is an item of cookware on the cooking zone and a power level has been set for that zone. The power level for vapour extraction is set to suit the power level of the cooking zone. After switching off the cooking zones, the cooker hood is gradually reduced and finally switched off.

You can deactivate Con@ctivity temporarily or permanently.

Extraction mode

The air is drawn in and cleaned by the grease filter and directed outside.

Guided recirculation mode

The air is drawn in and cleaned by the grease filter. The air is then also cleaned by a charcoal filter. The air is then circulated back into the kitchen via an air duct.

Plug & Play mode

Without an air duct, the air flows into the base unit and back into the kitchen through openings. Please follow the instructions in "Installation".

Cooker hood power levels

Select power levels **1** to **3** for light to heavy cooking vapours, odours or heat.

The power levels can be adjusted from 1 to 9. Increase the power level as the level of vapours, odours or heat increases.

Cooker hood Booster function

For short periods of cooking food with intensive vapours, odours or heat, e.g. when searing meat, select Booster level **B**.

Run-on

The run-on function enables the cooker hood to continue running for a pre-determined time before switching itself off automatically.

This helps to remove any lingering vapours and odours from the air after cooking. It also reduces the risk of residues accumulating in the cooker hood and any resultant odours.

Operating hours counter

The number of hours that the cooker hood has been used for is stored in memory.

When the  *Grease filter indicator* sensor control lights up, the grease filter must be cleaned.

When the  *Charcoal filter indicator* sensor control lights up, the charcoal filter must be replaced or reactivated (if suitable for reactivating).

You can set the operating hours counter intervals to suit the type of cooking you do.

The operating hours counter for the charcoal filter is deactivated in extraction mode.

Settings

You can adapt the settings of the hob to your personal needs.

Demo mode

This special function enables the hob to be demonstrated in dealer showrooms without heating up.

Residual heat indicator

If a cooking zone is still hot, the residual heat indicator will light up after all cooking zones have been switched off.

The bars of the residual heat indicator go out one after the other as the cooking zone cools down. The last bar only goes out when the cooking zone is safe to touch.

Safety switch-off

Sensor controls are covered

Your hob will switch off automatically if one or several of the sensor controls remain covered for longer than 10 seconds; for example, by finger contact, food boiling over or by an object.  will flash briefly in the timer display and

a buzzer will sound.  will go out once you have removed the obstruction and/or soiling and the hob will be ready to use again.

Excessive operating time

The safety switch-off is triggered automatically if a cooking zone is heated for an unusually long period of time. This time depends on the power level selected. If the time has been exceeded, the cooking zone switches off and the residual heat indicator appears on the hob. If you switch the cooking zone off and on again, it is ready for operation again.

You can adjust the safety switch-off by changing the safety setting.

Power level ¹	Maximum operating time [h:min]		
	Safety setting		
	0 ²	1	2
1	10:00	8:00	5:00
1.	10:00	7:00	4:00
2/2.	5:00	4:00	3:00
3/3.	5:00	3:30	2:00
4/4.	4:00	2:00	1:30
5/5.	4:00	1:30	1:00
6/6.	4:00	1:00	00:30
7/7.	4:00	00:42	00:24
8	4:00	00:30	00:20
8.	4:00	00:30	00:18
9	1:00	00:24	00:10

¹ The power levels with a dot are intermediate levels.

² Factory default setting

Familiarisation

Overheating protection

In order to prevent the hob from being damaged by excessive temperatures, the overheating protection mechanism intervenes in one of the following ways:

Overheating protection measures

- If the Booster function is switched on, it will stop.
- The set power level will be reduced.
- A cooking zone will switch off. *Err* flashes alternately with *044* in the timer display.
- All cooking zones will switch off.

Triggering the overheating protection mechanism

The overheating protection mechanism may be activated under the following circumstances:

- The cookware being heated is empty.
- Fat or oil is being heated on a high power level.
- Insufficient ventilation to the underside of the hob.
- A hot cooking zone is switched back on after an interruption to the power supply.

Model identifier and serial number

Your hob can display the model identifier and serial number.

Software version

Your hob can display its software status.

Unpacking the hob

- Please stick the data plate for the appliance, supplied with this documentation, in the space provided in the “After sales service” section of this booklet.
- Remove any protective foil and stickers.

Cleaning the hob for the first time

- Before using for the first time, clean the hob with a damp cloth.
- Wipe the hob dry.

Switching on the hob for the first time

The metal components have a protective coating. When the hob is used for the first time, this causes a smell and possibly also vapour. The heating of the induction coils also causes odours in the first few hours of operation. With each subsequent use, the odour is reduced until it disappears completely.

The odour and any vapours given off do not indicate a faulty connection or appliance and they are not hazardous to health.

Using the vapour extractor for the first time

Only: KMDA 7676 FL-U

- Fit the charcoal filter.

Networking

The WiFi connection shares a frequency range with other appliances (including microwave ovens and remote control toys). This can give

rise to sporadic or even complete connection failures. Therefore, the availability of featured functions cannot be guaranteed.

Connecting to a network via the app

- A home WiFi network is available.
- The signal of your WiFi network is sufficiently strong in the place where your hob is installed.
- There is no direct WiFi connection between the hob and a Miele cooker hood.



- Scan the QR code.

If you have installed the Miele app and have a user account, you will be taken directly to the networking steps.

If you have not yet installed the Miele app, you will be taken to the Apple App Store® or the Google Play Store™.

- Install the Miele app and set up a user account.
- Scan the QR code again.

The Miele app will guide you through the setup process.

Connecting to a network via WPS

- A home WiFi network is available.
- The signal of your WiFi network is sufficiently strong in the place where your hob is installed.
- There is no direct WiFi connection between the hob and a Miele cooker hood (Con@ctivity).
- You must have a WPS (WiFi protected setup) compatible router.

- Touch any cooking zone indicator.

Commissioning

- Touch the 0 and 6 sensor controls at the same time for 6 seconds.

The seconds can be seen counting down in the timer display. After the time has elapsed, a progress light appears in the timer display during the connection attempt (for max. 120 seconds).

The WPS login is active during these 120 seconds.

- Activate the WPS function on your WiFi router.

If the connection was successful, the code **C:02** will appear on the timer display. If the connection could not be established, the timer display will show the code **C:01**. You have probably not activated WPS on your router quickly enough. Repeat the steps above.

- Install the Miele app.
- Follow the user navigation in the app.

You can use all Miele app functions.

Tip: If your WiFi router does not support WPS, please connect via the Miele app.

Cancelling the process

- Touch any sensor.

Resetting settings

Reset the settings if you are disposing of your hob, selling it or putting a used hob into operation. This is the only way to ensure that all personal data has been removed and the previous owner will no longer be able to access the hob.

Resetting is not required when replacing the router.

- Switch the hob on.
- Touch any cooking zone indicator.

- Touch the 0 and 9 sensor controls at the same time for 6 seconds.

The seconds can be seen counting down in the timer display.

When the timer expires, the timer display shows the code **C:00** for 10 seconds.

Safety notes for operation

 Risk of fire due to over-heated food.

Unattended food can overheat and catch alight.

Do not leave the hob unattended whilst it is being used.

 Risk of burning due to hot cooking zones.

The cooking zones will be hot after use.

Do not touch the cooking zones while the residual heat indicators are on.

 Risk of burning due to hot items.

When the hob is switched on either deliberately or by mistake, or when there is residual heat present, there is the risk of metal items placed on the hob heating up.

Do not use the hob as a resting place for anything.

After use, switch the hob off with the  sensor control.

 Placing hot cookware on the sensor controls and displays can damage the electronic module underneath.

The sensor controls do not respond.

They may be switched on or off unintentionally.

The hob switches itself off.

Do not place hot cookware over the sensor controls or displays.

Switching the hob on

- Touch  *On/Off*.

Other sensor controls light up.

If no further entry is made, the hob will switch itself off after a few seconds for safety reasons.

Switching the hob/a cooking zone off

Switching the hob off

- To switch off the hob and all the cooking zones, touch  *On/Off*.

Switching a cooking zone off

- To switch off a cooking zone, touch the relevant cooking zone indicator.

The cooking zone display lights up brightly.

The other cooking zone displays light up dimly.

- Touch *0* on the numerical display.

Operation

Hob power levels

Setting the power level

Permanent pan recognition is activated as standard. When the hob is switched on and you place an item of cookware on a cooking zone, the cooking zone indicator starts to flash.

- Place the cookware on the cooking zone you want to use.
- Touch the appropriate sensor control for the power level you want on the numerical display.

Setting the power level – intermediate levels

The intermediate levels are activated.

- Press the numerical display between the sensor controls.

The hob display shows a dot next to the power level.

The sensor controls in front of the intermediate level are brightly lit. The other sensor controls light up dimly.

Example:

If you have set power level 7., the cooking zone display will show 7..

Number 7 lights up brightly on the numerical display. The other sensor controls light up dimly.

Changing the power level

- Touch the relevant cooking zone indicator.

The cooking zone display lights up brightly. The other sensor controls light up dimly.

- Touch the appropriate sensor control for the power level you want on the numerical display.

Linking/unlinking PowerFlex cooking zones manually

At least one PowerFlex cooking zone is selected.

- To manually link or unlink the PowerFlex cooking zones, touch the  *PowerFlex XL*.

Booster

Activating the Booster

When the Booster is activated, the settings for the linked cooking zone may be changed.

You can use the Booster:

- On any cooking zone on either side
or
- On both cooking zones on one side
or
- On a PowerFlex XL cooking area

The Booster function is active for a maximum of 15 minutes.

TwinBooster level 1

- Place the cookware on the cooking zone you want to use.
- Select a power level if necessary.
- Touch **B *Booster***.

The cooking zone display shows *.*

TwinBooster level 2

- Place the cookware on the cooking zone you want to use.
- Select a power level if necessary.
- Touch **B *Booster 2*** times.

The cooking zone display shows *..*

Deactivating the Booster

- Touch **B *Booster***.

or

- Set another power level.

If you deactivate the Booster function or the Booster time comes to an end and

- no power level was selected before activating the Booster, the cooking zone will revert automatically to level 9.
- a power level was selected before activating the Booster, the cooking zone will revert automatically to the previously selected level.

Stop&Go

Activating Stop&Go

All timer functions, booster times and heat-up boost times continue to run. The timer settings cannot be changed. The hob can only be switched off.

If the special function is not deactivated within 1 hour, the hob will switch off.

- Touch  *Menu*.
- Touch **II** ▶ *Stop&Go*.

Deactivating Stop&Go

- Touch **II** ▶ *Stop&Go*.

Auto heat-up

The heat-up time depends on which continued cooking setting has been chosen:

Continued cooking level ¹	Heat-up time [min:sec]
1	Approx. 00:15
1.	Approx. 00:15
2	Approx. 00:15
2.	Approx. 00:15
3	Approx. 00:25
3.	Approx. 00:25
4	Approx. 00:50
4.	Approx. 00:50
5	Approx. 2:00
5.	Approx. 5:50
6	Approx. 5:50
6.	Approx. 2:50
7	Approx. 2:50
7.	Approx. 2:50
8	Approx. 2:50
8.	Approx. 2:50
9	—

¹ The power levels with a dot are intermediate levels.

Activating auto heat-up

No timer functions can be set during the heat-up time.

- Touch the cooking zone indicator for the required cooking zone.
- Touch the sensor control for the continued cooking level you want until a tone sounds and the cooking zone display shows *H*.

The power level flashes alternately with *H* while the heat-up boost (power level 9) is running.

Deactivating auto heat-up

- Touch the cooking zone indicator for the required cooking zone.

Operation

- Touch the continued cooking setting you have set until the *R* switches off.

or

- Set another power level.

Timers

Setting the time

A time of between 1 minute (0:01) and 9 hours 59 minutes (9:59) can be set.

Times of up to 59 minutes are shown in minutes (00:59) and times of more than 60 minutes are shown in hours and minutes.

The time is entered using the numerical display and can be adjusted using the + *Input*.

- Enter the duration in the order of hours, followed by minutes in tens and then units.

Example:

59 minutes = 00:59 hours,

Enter: 5-9

80 minutes = 1:20 hours,

Enter: 1-2-0

After the first number has been entered the timer display will light up constantly. After the second number has been entered, the first number will move to the left. After the third number has been entered, the first and second numbers will move to the left.

Setting the minute minder

- Touch  *Menu*.
- Touch  *Minute minder*.

The timer display starts flashing.

- Set the required time.

Touch  *Minute minder* or wait 10 seconds to start the timer.

Changing the minute minder duration

- Touch  *Minute minder*.

The timer display starts flashing.

- Set the required time.

Touch  *Minute minder* or wait 10 seconds to start the timer.

Deleting the minute minder duration

- Touch  *Minute minder*.
- Touch 0 on the numerical display.

Setting the switch-off time

A cooking zone will switch off when the maximum operating time has elapsed, regardless of the switch-off time that has been set.

A power level is set for the desired cooking zone.

- Touch  *Auto switch off* next to the relevant cooking zone indicator.

The timer display starts flashing.

- Set the required time.

Touch  *Auto switch off* or wait 10 seconds to start the switch-off time.

The switch-off time for the cooking process will count down and the cooking zone  *Auto switch off* will light up constantly.

Changing the switch-off time of a cooking process

- Touch the required cooking zone indicator.
- Touch  *Auto switch off* next to the relevant cooking zone indicator.

The timer display starts flashing.

- Set the required time.

Touch \ominus *Auto switch off* or wait 10 seconds to start the switch-off time.

The switch-off time for the cooking process will count down and the cooking zone \ominus *Auto switch off* will light up constantly.

Deleting the switch-off time for a cooking process

- Touch the required cooking zone indicator.
- Hold down \ominus *Auto switch off* for the cooking zone you want to use until the timer display shows 0:00.

or

- Touch \ominus *Auto switch off* next to the relevant cooking zone indicator.

The timer display starts flashing.

- Touch 0 on the numerical display.

Setting the switch-off time for further cooking processes

- To set a switch-off time for a further cooking process, follow the same steps as described under “Operation – Setting the switch-off time for a cooking process”.

If a switch-off time is set for further cooking processes, the time left for the selected cooking zone is displayed. \ominus *Auto switch off* lights up brightly next to the corresponding cooking zone display. The other sensor controls light up dimly.

Displaying the switch-off time of a cooking process

- If you want to show the time left which is counting down in the background, touch the \ominus *Auto switch off* for the required cooking zone.

The **rounded up** time left is displayed for the required cooking zone.

Using both timer functions at the same time

If you use both functions at the same time, the time of the last selected function is always displayed.

- Touch \triangle *Minute minder* or the relevant cooking zone indicator if you want to show the times left counting down in the background.

System lock

Activating the system lock

All sensor controls are locked. A set timer will continue to count down.

- Touch and hold \ominus *On/Off* for 6 seconds.

The seconds can be seen counting down in the timer display. When the timer expires, the timer display shows *LDC*. The system lock is activated.

If a disallowed sensor control is touched while the system lock is activated, the timer display will show *LDC* for a few seconds and a tone will sound.

The settings can be adjusted so that the system lock is activated automatically 5 minutes after the hob has been switched off.

Deactivating the system lock

- Touch and hold \ominus *On/Off* for 6 seconds.



The timer display briefly shows *LDC*, then the seconds can be seen counting down in the timer display. The system lock is deactivated once the time has elapsed.

Operation

Lock

Activating the safety lock

When the safety lock is activated:

- The cooking zones, the hob and the cooker hood can only be switched off.
- A set minute minder time can be modified.
-  *Menu* can be activated.
- Touch  *Menu*.
- Touch **II** *Stop&Go* and  *Minute minder* at the same time for 6 seconds.

The seconds can be seen counting down in the timer display. When the timer expires, the timer display shows *LDC*. The safety lock is activated.

If a disallowed sensor control is touched while the safety lock is activated, the timer display will show *LDC* for a few seconds and a tone will sound.

Deactivating the safety lock

- Touch **II** *Stop&Go* and  *Minute minder* at the same time for 6 seconds.

The timer display briefly shows *LDC*, then the seconds can be seen counting down in the timer display. Once the time has elapsed, the safety lock function is deactivated.

Activating the Recall function

- Switch the hob on again.
- Immediately after switching the hob on, touch one of the flashing cooking zone indicators.

All settings are restored.

Activating/deactivating the Keeping warm function

The Keeping warm function cannot be used to reheat food that has gone cold.

- Touch the cooking zone indicator for the required cooking zone.

The cooking zone display lights up brightly.

The other sensor controls light up dimly.

- Touch  *Keeping warm*.



The corresponding cooking zone display shows *h*.

Tips for keeping food warm

- Only use cookware (pots/pans) for keeping food warm. Cover the cookware with a lid.
- Stir firm or viscous food (mashed potatoes, stew) occasionally.
- Nutrients are lost when food is cooked, and continue to diminish when food is kept warm. The longer food is kept warm, the greater the loss of nutrients. Try to ensure that food is kept warm for as short a time as possible.

Wipe protection

Activating wipe protection

- Touch  *Menu*.
- Touch  *Wipe protection*.

The time counts down in the timer display.

Deactivating wipe protection

- Touch the  *Wipe protection* until the timer display goes out.

Vapour extraction

Manually setting the cooker hood power level

If the cooker hood is not switched off manually, it will switch itself off automatically 12 hours after last being used.

If the cooker hood starts at power level 1, the power is automatically increased to level 2 for 20 seconds.

The increase in power is necessary in order to ensure that the flap opens in extraction mode. If you are using the cooker hood in recirculation mode, you can deactivate this automatic function.

- Touch the vapour extraction display.
- Touch the appropriate sensor control for the power level you want.

Manually switching off the cooker hood

- Touch the vapour extraction display.
- Touch **0** on the numerical display.

Activating the Booster

The Booster function is active for a maximum of 10 minutes.

- Touch the vapour extraction display.
- Touch **B Booster**.

Deactivating the Booster

- Touch the vapour extraction display.
- Set another power level.

Deactivating Con@ctivity temporarily

If you want to deactivate Con@ctivity permanently, you will need to change the Con@ctivity programming. If Con@ctivity is permanently deactivated,  Con@ctivity will no longer be visible.

- You can deactivate Con@ctivity in various ways:
 - Touch  Con@ctivity
 - Touch **0** on the numerical display.
 - Select a different power level
- Set the power level you want.

Depending on the programming, Con@ctivity will be reactivated when you switch the hob off and back on again.

Run-on





If recirculation mode is set, the cooker hood runs at level 1.

Depending on the last active power level, run-on lasts between 2 and 30 minutes.

Do not cancel the run-on function prematurely. Especially in Plug & Play mode, the run-on ensures that the base unit is dried.

In extraction mode without Con@ctivity, manually activate the run-on.

Manually activating run-on

- After you have finished cooking, touch the sensor control with the cooker hood switched on:
 - : The cooker hood switches off after 5 minutes.
 - : The cooker hood switches off after 15 minutes.
-  5 minute run-on or  15 minute run-on lights up brightly. The other sensor controls light up dimly.

Deactivating run-on

If you switch the hob off with  On/Off, the run-on period will continue through to the end.

- Touch **0** on the numerical display.

Activating/deactivating demo mode

There is cookware on the hob.

- Switch the hob on.

Operation

- Touch the 0 and 2 sensor controls on the numerical display at the same time for 6 seconds.

The timer display flashes for a few seconds:

- dE alternating with On (demo mode activated)
- or
- dE alternating with OFF (demo mode deactivated)

Setting ranges for the hob power levels

The hob is programmed with 9 power levels without intermediate levels at the factory. If you wish to fine-tune the power levels, you can activate intermediate levels via the settings.

	Setting range	
	Factory setting 9 levels without intermediate levels	fine 9 levels with intermediate levels
Melting butter Melting chocolate Dissolving gelatine	1–2	1–2.
Warming up small quantities of liquid Keeping warm food which sticks easily Cooking rice or porridge Defrosting vegetables frozen in a block	2–4	2–3.
Warming up liquid and semi-solid food Steaming fruit Simmering potatoes (cookware with lids)	4–6	3.–5.
Making omelettes or lightly fried eggs Gently frying meat patties Steaming fish and vegetables Cooking dumplings and dried pulses Defrosting and reheating frozen food Thickening sauces, e.g. Hollandaise Pancakes	5–7	4.–7.
Gently frying (without overheating the fat) fish, escalopes, sausages, fried eggs, etc.	6–8	6–7.
Cooking hash browns, pancakes, etc.	7–8	7–8.
Frying, e.g. chips	9	8.–9
Boiling large quantities of water Bringing to the boil Searing large quantities of meat	9–Booster	8.–Booster

These settings should only be taken as a guide. The power of the induction coils will vary depending on the size and material of the cookware. For this reason, the power levels may need to be adjusted slightly to suit your cookware. As you use the hob, you will get to know which settings suit your cookware best. When using new cookware that you are not familiar with, set the power level to one level below the one specified.

Notes for test institutes

Test food acc. to EN60350-2

9 power levels without intermediate levels are programmed at the factory.

For testing in accordance with the above standard, programme the hob to 9 power levels with intermediate levels (see “Adjusting settings”).

Setting ranges for the hob power levels

Test food	Ø Pan base (mm)	Lid	Setting range	
			Pre-heat	Cook
Heating oil up	150	No	–	1–2
Pancakes	180 (Sandwich base)	No	9	5.–7.
Frying deep frozen chips	According to the standard	No	9	9

Your hob

How induction hobs work

An induction coil is located under each induction cooking zone. The coil creates a magnetic field that reacts directly with the base of the cookware and heats it up. The cooking zone itself is heated up indirectly by the heat given off by the cookware.

An induction cooking zone only works when cookware with a magnetic base is placed on it. The hob automatically detects the size of the cookware.

Noises

When using induction cooking zones, the following noises can occur in the cookware, depending on what it is made of and how it has been constructed:

Buzzing on the higher power levels. This will decrease or cease altogether when the power level is reduced.

If the cookware base is made of layers of different materials (e.g. in a sandwiched base), it might emit a crackling sound.

Whistling might occur if linked cooking zones are being used at the same time and the cookware also has a base made of layers of different materials (e.g. sandwich base).

You might hear a clicking sound from the electronic switches, especially at lower power levels.

A whirring sound, when the cooling fan comes on. This switches on to protect the electronic module when the hob is being used intensively. The cooling fan may continue to run after the hob has been switched off.

Cookware

Suitable cookware

- Stainless steel cookware with a magnetic base
- Enamelled steel cookware
- Cast iron

Please be aware that the properties of the cookware base can affect the evenness with which the food heats up (e.g. when making pancakes). The base of the cookware must be able to distribute the heat evenly. Cookware with a base made from multilayer material (sandwich or encapsulated base) is ideal in this case.

Unsuitable cookware

- Stainless steel cookware without a magnetic base
- Aluminium or copper cookware
- Glass, ceramic or earthenware cookware

Testing cookware

To test whether a pot or pan is induction-compatible, hold a magnet to the base. If the magnet sticks, the pan is generally suitable.

Cookware tips

- Position the cookware as centrally as possible on the relevant cooking zone/cooking area.
- To make optimum use of the cooking zones, choose cookware with a suitable base diameter. If a pan is too small, it will not be detected.
- Use only pots and pans with smooth bases. Rough bases can scratch the ceramic surface.

Good to know

- When cooking zones are joined together, we recommend using cookware which more or less covers the entire cooking area (e.g. an oven dish).
- Always lift cookware to move it. This will help prevent scratching. If any scratches do appear as a result of cookware being pushed around, this will not affect the function of the hob. These scratches are normal signs of use and are not grounds for making a complaint.
- Please note that the cookware diameter quoted by manufacturers often refers to the maximum diameter or diameter of the top rim. The diameter of the base (generally smaller) is more important.

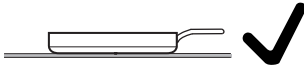

- Where possible, use cookware with vertically straight sides. If an item of cookware has angular sides, induction also acts on the sides of the item of cookware. The sides of the item of cookware may discolour or the coating may peel off.

Your cooker hood

How the cooker hood works

What happens to the air after extraction varies depending on the type of operation selected:

Air guidance	Grease filter	Duct	Charcoal filter	Out of the building	Back into the kitchen
Extraction mode	x	x	-	x	-
Guided recirculation mode	x	x	x	-	x
Plug & Play mode	x	-	x	-	x

A summary of the operating options and the KMDA variants that offer them can be found in “Installation – Operating options”.

Air extraction tips

Tip: For light to heavy cooking vapours and odours, select power levels **1** to **3** (9 if the power level settings for the cooker hood have been modified). For short periods of very strong vapours and odours, e.g. whilst searing meat, select the Booster setting **B**.

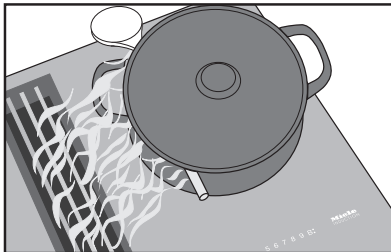
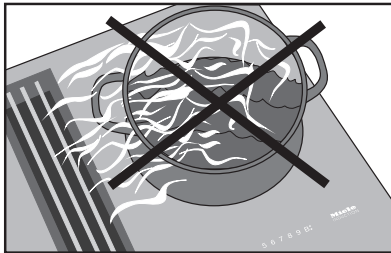

Tip: To help extract air effectively with pans over 15 cm high, place a wooden spoon between the lid and the pan.

Good to know

Tip: Cookware with an optimised outlet for the vapours can be found in “Familiarisation – Optional accessories”.

Accessing the Settings menu

The hob is switched off.

- Touch $\text{\textcircled{1}}$ *On/Off* and $\overline{\text{III}}$ *Keeping warm* at the same time until + *Input* lights up and the timer display shows *PC*.

After a few seconds, *P:01* (programme 01) will flash alternately with *C:01* (code) on the timer display.

Setting parameters

For a two-digit parameter number you need to first set the tens position.

- While a parameter (e.g. *P:01*) is visible in the display, press + *Input* repeatedly until the number for the parameter you want appears in the timer display or touch the appropriate number on the numerical display.

Setting the code

- While a code (e.g. *C:00*) is visible in the display, press + *Input* repeatedly until the number for the code you want appears in the timer display or touch the appropriate number on the numerical display.

Saving the settings

- While a parameter is showing in the display (e.g. *P:01*) touch $\text{\textcircled{1}}$ *On/Off* until the indicators go out.

To avoid saving the settings

- While the code is showing in the display (e.g. *C:01*) touch the $\text{\textcircled{1}}$ *On/Off* sensor until the indicators go out.

Adjusting settings

Parameter ¹		Code	Settings ²
P:01	Demo mode	C:00	Demo mode off
		C:01	Demo mode on ³
P:02	Power management ⁴	C:00	Off
		C:01	3680 W
		C:02	3000 W
		C:03	2000 W
		C:04	1000 W
P:03	Factory default	C:00	Do not restore factory default settings
		C:01	Restore factory default settings ⁵
P:04	Hob power level setting range	C:00	9 power levels without intermediate levels + Booster
		C:01	9 power levels with intermediate levels + Booster ⁶
P:06	Keypad tone when a sensor control is touched	C:00	Off ⁷
		C:01	Quiet
		C:02	Medium
		C:03	Loud
P:07	Timer buzzer	C:00	Off
		C:01	Quiet
		C:02	Medium
		C:03	Loud
		C:04	Maximum volume

Adjusting settings

Parameter ¹		Code	Settings ²
P:08	System lock	C:00	System lock can only be activated manually
		C:01	System lock activated automatically
P:09	Maximum operating time	C:00	Safety setting 0
		C:01	Safety setting 1
		C:02	Safety setting 2
P:10	WiFi registration	C:00	Not active/deactivated
		C:01	Active but not configured
		C:02	Active and configured (cannot be selected; displays whether connection was successful)
		C:03	Connection possible via WPS push button
		C:04	WiFi reset to default (C:00)
		C:05	Direct WiFi connection of hob and external cooker hood without Miele app (Con@ctivity)
P:12	Sensor control reaction speed	C:00	Slow
		C:01	Normal
		C:02	Fast
P:15	Permanent pan recognition	C:00	Permanent pan recognition off
		C:01	Permanent pan recognition on
P:16	Con@ctivity of the integrated extractor	C:00	Con@ctivity off ⁸
		C:01	Con@ctivity on

Adjusting settings

Parameter ¹		Code	Settings ²
P:17	Operating mode of the integrated extractor	C:00 ⁹	Recirculation mode
		C:01 ⁹	Extraction mode
P:18	Start settings of Con@ctivity ¹⁰	C:00	Always start with Con@ctivity deactivated
		C:01	Always start with Con@ctivity activated
		C:02	Start with the most recently set Con@ctivity state
P:19	Number of vapour extraction power levels	C:00	3 power levels + Booster
		C:01	9 power levels + Booster

¹ Programmes not shown here have no allocation.

² The factory default setting is shown in bold.

³ After turning on the hob, the timer display shows *dE* for a few seconds.

⁴ The total hob power may be reduced in order to meet the local power supply provider's requirements.

⁵ The settings for the P:17 operating mode of the vapour extractor will not be reset to the factory default settings.

⁶ In the text and charts, the intermediate levels are shown with a dot after the number for better understanding.

⁷ The keypad tone of ① *On/Off* cannot be switched off.

⁸ Plug & Play mode: Con@ctivity is required for correct operation.

⁹ Factory-set code:

KMDA 7676 FL-U: C:00

KMDA 7676 FL-A: C:01

¹⁰ The settings only take effect if Con@ctivity has been activated in the P:16 programme.

Displaying the model identifier/ serial number

There is cookware on the hob.

- Switch the hob on.
- Touch the 0 and 4 sensor controls on the numerical display at the same time for 6 seconds.

Numbers will appear in the timer display one after another, separated by a dash.

Example: *12 34* (model identifier KMDA 1234) – *1 23 45 67 89* (serial number)

Displaying the software ver- sion

There is cookware on the hob.

- Switch the hob on.
- Touch the 0 and 3 sensor controls on the numerical display at the same time for 6 seconds.

The timer display shows 3 digits:

Example: *123* = software version 1.23.

Safety notes on cleaning and care

 Risk of burning due to hot surfaces.

All parts of the hob may be hot after use.

Switch the hob off.

Allow the hob to cool down before cleaning it.

All surfaces could be discoloured or damaged if unsuitable cleaning agents are used or if residues from suitable cleaning agents are heated on the hob. All surfaces are susceptible to scratching.

Allow the surfaces to cool down before cleaning the hob.

Remove all cleaning agent residues immediately.

Never use abrasive sponges or cleaning agents.

 Risk of fire due to soiled grease filter.

Grease collected in the grease filter can ignite.

Clean the grease filter regularly.

 Risk of injury due to the fan motor.

The fan motor rotates while the vapour extraction is active.

Switch the hob off.

Wait until the run-on cycle is finished, if applicable.

 Do not use a steam cleaner to clean the hob.

 Do not use pointed objects for cleaning.

When to clean

- Before each use:
Clean the entire hob and the base of the cookware.
- After every use:
Clean the entire hob.
- Once a week:
To prevent cleaning agent residue being burned on, clean the ceramic surface with the Miele ceramic and stainless steel cleaner or with a proprietary ceramic glass cleaner. Please follow the cleaning agent manufacturer's instructions.

Cleaning the ceramic glass surfaces

Removing light soiling

- Clean the entire ceramic surface of the hob with a damp, soft cloth and a solution of water and a little washing-up liquid. Please follow the cleaning agent manufacturer's instructions.

Removing stubborn soiling

- Remove any coarse soiling with a damp cleaning cloth and more stubborn soiling with a glass scraper.
- Clean the ceramic surface with the Miele ceramic and stainless steel cleaner or with a proprietary ceramic glass cleaner. Please follow the cleaning agent manufacturer's instructions.

Finishing the cleaning process

- Remove all cleaning agent residues with a damp cleaning cloth.

- Dry the ceramic surface of the hob after cleaning.

Unsuitable cleaning agents

To avoid damaging the surfaces of the appliance, do not use:

- Cleaning agents containing soda, alkalines, ammonia, acids or chlorides
- Stain and rust removers
- Abrasive cleaning agents, e.g. powder cleaners and cream cleaners
- Cleaning agents containing solvents
- Dishwasher cleaning agents
- Grill and oven sprays
- Hard, abrasive brushes
- Eraser stain remover blocks
- Sponges

Parts suitable for dishwashers

You can clean the removable components of your hob as follows:

	Automatic	By hand
Cover grille	X	X
Grease filter	X	X
Drip tray	X	X
Cleaning flap	X	X

Cover grille

Removing the cover grille

The cover grille could be damaged. Pull the cover grille vertically out of the top of the KMDA.

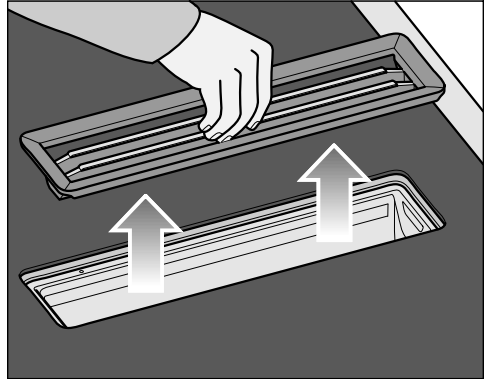

- Take hold of the cover grille in the centre of the bars.
- Pull the cover grille vertically upwards.

Cleaning the cover grille by hand

- Clean the cover grille with a soft nylon brush in a mild solution of hot water and a little washing-up liquid. Do not use concentrated washing-up liquid.

Cleaning the cover grille in the dishwasher

- Place the cover grille upright in the lower basket.
- Use a standard household dishwasher detergent.
- Select a dishwasher programme with a maximum wash temperature of 55 °C.

Cleaning and care

Grease filter

Removing the grease filter

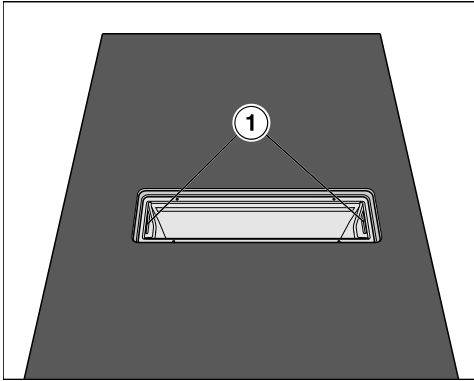

- Remove the cover grille.
- Carefully remove the grease filter using the recessed grips (1). Ensure that you do not tilt the grease filter.
- Pour out any liquid which has collected at the bottom of the grease filter.

Cleaning the grease filter by hand

- Clean the grease filter with a soft nylon brush in a mild solution of hot water and a little washing-up liquid. Do not use concentrated washing-up liquid.

Important information on cleaning in a dishwasher

Excessively high temperatures can render the grease filter unusable (e.g. due to being warped out of shape). Select a programme that does not exceed the recommended temperature.

Also follow the information provided in the operating instructions for the dishwasher.

Depending on the cleaning agent used, the internal filter surfaces may become discoloured. However, this will not affect the functioning of the grease filter in any way.

Cleaning the grease filter in the dishwasher

- Place the grease filter with its base facing upwards in the lower basket. Ensure the spray arm is not obstructed.
- Use a standard household dishwasher detergent.
- Select a dishwasher programme with a maximum wash temperature of 65 °C.

Fitting the grease filters

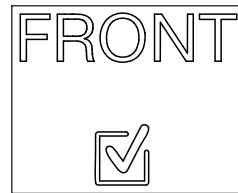

The grease filter has a symbol on the front.

- Insert the grease filter so that the symbol is pointing towards the front of the worktop.

Replacing the grease filter

Regular usage and cleaning can cause the filter surfaces to become worn.

If you identify any damage, replace the grease filter.

Grease filters are available to order via the Miele Customer Service Department (see end of these operating instructions for contact details) or from your Miele dealer.

Resetting the grease filter operating hours counter

After cleaning the grease filter, the operating hours counter needs to be reset.

- Touch and hold  *Grease filter indicator* for 3 seconds.

The sensor control goes out.

Charcoal filter (only KMDA 7676 FL-U)

Replacing the charcoal filter (only KMDA 7676 FL-U)

The charcoal filter must be replaced after 120 operating hours.  *Charcoal filter indicator* is illuminated.

The charcoal filters listed here are suitable for the KMDA variants covered by these operating instructions:

- DKF 35-P
- DKF 35-S
- Remove the cover grille.
- Remove the grease filter.

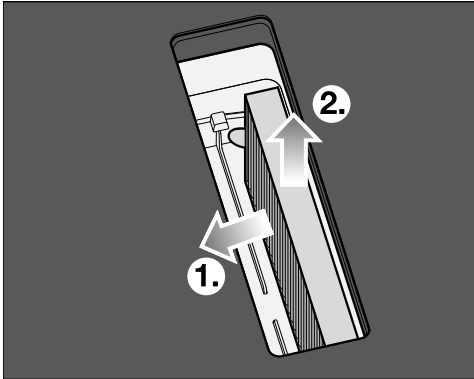

- Remove the charcoal filter.

Resetting the charcoal filter operating hours counter (only KMDA 7676 FL-U)

The operating and installation instructions supplied with the recirculation box state that the operating hours counter for the charcoal filter needs to be activated. This is not necessary here.

 *Charcoal filter indicator* is also illuminated when the vapour extractor is operated using extraction mode.

- Touch and hold  *Charcoal filter indicator* for 3 seconds.



The sensor control goes out.

Cleaning the cooker hood drip tray

Clean the drip tray if liquid from food being spilled or boiling over has got into the cooker hood.

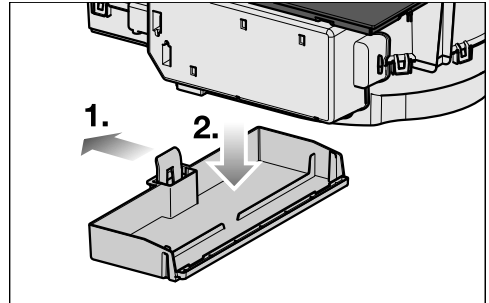
- Remove and clean the grease filter as described in “Cleaning and care – Grease filter”.



- Push the plastic bracket to the left  until the drip tray can be pulled downwards .
- Pour out the liquid.
- Clean and dry the drip tray.
- Also clean and dry accessible areas inside of the cooker hood.
- Fasten the drip tray back onto the casing.
- Replace the grease filter and refit the cover grille.

Cleaning inside the cooker hood casing

- Remove the grease filter.
- Clean off any accessible oil or fat build-up from the casing.

Cleaning the inside of the fan unit

Clean the inside of the fan unit if liquid from food being spilled or boiling over has got into the cooker hood.

- Clean the cooker hood drip tray.
- Place a container under the cleaning flap to catch the liquid.

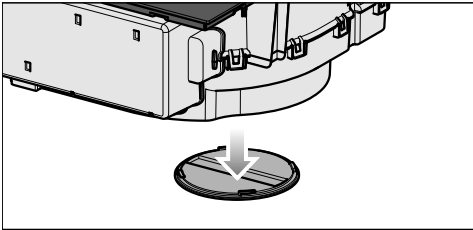

- Turn the cleaning flap to the left.
- Let the liquid run out.
- Turn the cleaning flap to the right as far as it will go.

Many malfunctions and faults can be easily remedied. You can save time and money in many cases, as you do not need to contact Customer Service.



More information to help you remedy faults yourself can be found at www.miele.de/support/customer-assistance.



Messages in the display

Problem	Cause and remedy
<p>Err flashes alternately with 30 in the timer display and a buzzer will sound.</p>	<p>The hob is incorrectly connected.</p> <ul style="list-style-type: none"> ■ Disconnect the hob from the mains power supply. ■ Contact the Customer Service Department. The hob must be connected to the mains according to the wiring diagram.
<p>On a cooking zone display, \cup lights up or flashes alternately with the selected power level or β.</p>	<p>No cookware is present on the cooking zone.</p> <p>Unsuitable cookware is present on the cooking zone.</p> <p>The diameter of the base of the cookware is too small.</p> <p>Suitable crockery has been removed from the cooking zone.</p> <p>If no cookware or unsuitable cookware is placed on the cooking zone, the cooking zone will switch off automatically after 3 minutes.</p> <ul style="list-style-type: none"> ■ Place a suitable item of cookware on the cooking zone within 3 minutes. <p>\cup goes out. The cooking process starts/continues with the previously selected settings.</p> <ul style="list-style-type: none"> ■ If you are using a different item of cookware and/or food, adjust the settings.
<p>After turning on the hob or touching a sensor, the timer display shows L0C for a few seconds.</p>	<p>The system lock is activated.</p> <ul style="list-style-type: none"> ■ Deactivate the system lock. <p>The safety lock is activated.</p> <ul style="list-style-type: none"> ■ Deactivate the safety lock.
<p>After turning on the hob, the timer display briefly shows dE. The cooking zones do not heat up.</p>	<p>The hob is in demo mode.</p> <p>There is cookware on the hob.</p> <ul style="list-style-type: none"> ■ Switching the hob on ■ Then touch 0 and 2 at the same time on the numerical display until dE flashes alternately with OFF in the timer display.

Troubleshooting

Problem	Cause and remedy
The hob has switched off automatically. When the hob is turned back on, ξ appears above $\textcircled{1}$ On/Off.	One or more of the sensor controls are covered, e.g. by finger contact, food boiling over or an object. <ul style="list-style-type: none"> ■ Remove the soiling and/or the object.
 Charcoal filter indicator lights up	The charcoal filter must be replaced. <ul style="list-style-type: none"> ■ Replace the charcoal filter. ■ Reset the operating hours counter.
 Grease filter indicator lights up	The grease filter must be cleaned. <ul style="list-style-type: none"> ■ Clean the grease filter.
 Con@ctivity is not lit	The Con@ctivity function of the cooker hood is permanently deactivated. <ul style="list-style-type: none"> ■ Activate the Con@ctivity function of the cooker hood in the programming.
A message not listed in this table is appearing in the timer display.	There is an electronic module fault. <ul style="list-style-type: none"> ■ Disconnect the power supply to the hob for approx. 1 minute. ■ If the problem persists after the power supply has been restored, please contact the Customer Service Department.

Unexpected behaviour

Problem	Cause and remedy
Power level 9 is automatically reduced if you also set power level 9 for the connected cooking zone.	Operating both zones at power level 9 exceeds the permitted maximum power for the two zones. <ul style="list-style-type: none"> ■ Use a different cooking zone.
A cooking zone or the whole hob switches off automatically.	It has been operated for too long. <ul style="list-style-type: none"> ■ Switch the hob or cooking zone on again.
	The overheating protection mechanism has been activated. <ul style="list-style-type: none"> ■ Allow the hob to cool down. ■ Rectify the causes of the overheating. ■ Check that the hob is working. ■ If the problem occurs again, contact the Customer Service Department.

Troubleshooting

Problem	Cause and remedy
The cooking zone is not working in the usual way with the set power level.	<p>The overheating protection mechanism has been activated.</p> <ul style="list-style-type: none">■ Allow the hob to cool down.■ Rectify the causes of the overheating.■ Check that the hob is working.■ If the problem occurs again, contact the Customer Service Department.
The Booster level has deactivated early automatically.	<p>The overheating protection mechanism has been activated.</p> <ul style="list-style-type: none">■ Allow the hob to cool down.■ Rectify the causes of the overheating.■ Check that the hob is working.■ If the problem occurs again, contact the Customer Service Department.

Unsatisfactory results

Problem	Cause and remedy
The food in the cookware does not heat up when the auto heat-up is switched on.	<p>Large quantities of food are being cooked.</p> <ul style="list-style-type: none">■ Start cooking at the highest power level and then switch back manually.
	<p>The cookware is not conducting heat properly.</p> <ul style="list-style-type: none">■ Use different cookware that is able to better conduct heat.

General problems or technical faults

Problem	Cause and remedy
<p>The hob or cooking zones will not switch on.</p>	<p>There is no power to the hob.</p> <ul style="list-style-type: none"> ■ Check whether the circuit breaker has tripped. Contact a qualified electrician or the Miele Customer Service Department (for the minimum fuse rating, see data plate). <hr/> <p>There may be a technical fault.</p> <ul style="list-style-type: none"> ■ Disconnect the hob from the electricity supply for approx. 1 minute. To do this: <ul style="list-style-type: none"> – Trip the relevant mains fuse or screw the fine-wire fuse out completely, or – Switch off at the residual current device. ■ If the hob will still not turn on after resetting the trip switch in the fuse box or the residual current device, contact a qualified electrician or the Miele Customer Service Department.
<p>A smell and vapours are given off when the new hob is being used.</p>	<p>The metal components have a protective coating. When the hob is used for the first time, this causes a smell and possibly also vapour. The material from which the induction coils are made also gives off an odour in the first few hours of operation. With each subsequent use, the odour is reduced until it disappears completely. The odour and any vapours given off do not indicate a faulty connection or appliance and they are not hazardous to health.</p>
<p>An operating noise can be heard after the hob has been switched off.</p>	<p>The cooling fan runs until the hob has cooled down and then switches off automatically.</p>
<p>Liquid has got into the vapour extractor.</p>	<p>Due to boiling over or spillage, liquid has made its way through the cover grille into the cooker hood.</p> <p>The base of the grease filter and the drip tray can hold approx. 800 ml of liquid in total.</p> <ul style="list-style-type: none"> ■ Switch the vapour extractor off. ■ Clean the grease filter, the drip tray, the inside of the casing and the fan motor compartment. ■ KMDA 7676 FL-U only: replace the charcoal filter.

Troubleshooting

Problem	Cause and remedy
Extraction power has decreased. Extraction noise has increased.	<p>Objects (e.g. a cloth) have been drawn into the cooker hood.</p> <ul style="list-style-type: none">■ Switch the vapour extractor off.■ Remove the grease filter.■ Remove any objects from the grease filter.

Customer Service

Information to help you rectify faults yourself and about Miele spare parts can be found at www.miele.com/service.

Contact in the event of a fault

In the event of a fault which you cannot remedy yourself, please contact your Miele dealer or Miele Customer Service.

You can book a Miele Customer Service call-out online at www.miele.com/service.
Contact information for Miele Customer Service can be found at the end of this document.

Please quote the model identifier and serial number of your appliance (SN) when contacting Miele Customer Service. These can be found on the data plate or see “Operation – Hob data”.

Data plate

Stick the extra data plate supplied with the appliance here. Make sure that the model identifier matches the one specified on the back cover of this document.

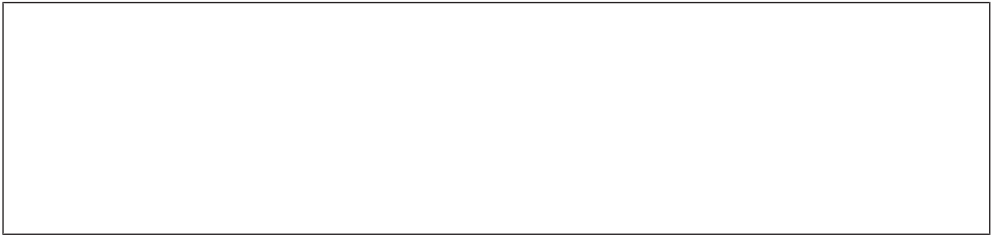

Warranty

For information on the appliance warranty specific to your country please contact Miele. See back cover for address.

In the UK, your appliance warranty is valid for 2 years from the date of purchase. However, you must activate your cover by calling 0330 160 6640 or registering online at www.miele.co.uk.

Technical data

Frequency range of the WiFi module	2,400 GHz – 2,4835 GHz
Transmission power of the WiFi module	≤ 100 mW
Power rating in off mode	≤ 0,5 W
Power rating in networked standby	≤ 2 W
Time until automatic switch to off mode	10 Min.
Time until automatic switch to networked standby	10 Min.

Product data sheets

The following product data sheets apply to the models described in these operating and installation instructions.

Information for domestic electric hobs

In acc. with regulation (EU) No. 66/2014

MIELE	
Model name/identifier	KMDA 7676 FL-A, KMDA 7676 FL-U
Number of cooking zones and/or areas	4
For circular cooking zones: diameter of useful surface area/cooking zone For non-circular cooking zones or areas: length and width of useful surface area per electric cooking zone or area	1. = 230x460 mm 2. = 230x460 mm 3. = 4. =
Energy consumption per cooking zone or area calculated per kg (EC _{electric cooking})	1. = 180,1 Wh/kg 2. = 180,7 Wh/kg
Energy consumption for the hob calculated per kg (EC _{electric hob})	180,4 Wh/kg

Data sheet for household cooker hoods

In acc. with delegated regulation (EU) No. 65/2014 and regulation (EU) No. 66/2014

MIELE	
Model name/identifier	KMDA 7676 FL-A
Annual Energy Consumption (AEC _{hood})	31,5 kWh/year
Energy efficiency class	A+
Energy efficiency index (EEI _{hood})	38,0
Fluid Dynamic Efficiency (FDE _{hood})	35,8
Fluid Dynamic Efficiency class	
A (most efficient) to G (least efficient)	A
Lighting Efficiency (LE _{hood})	0,0 lx/W
Lighting Efficiency class	

Technical data

A (most efficient) to G (least efficient)	NA
Grease Filtering Efficiency	95,1%
Grease Filtering Efficiency class	
A (most efficient) to G (least efficient)	A
Airflow at best efficiency point	321,0 m ³ /h
Air flow (min. speed)	195 m ³ /h
Air flow (max. speed)	538 m ³ /h
Air flow (intensive or boost setting)	615 m ³ /h
Max. air flow (Q _{max})	615,0 m ³ /h
Air pressure at best efficiency point	494 Pa
Airborne acoustical A-weighted sound power emissions (min. speed)	41 dB
Airborne acoustical A-weighted sound power emissions (max. speed)	64 dB
Airborne acoustical A-weighted sound power emissions (intensive or boost setting)	67 dB
Electrical power input at best efficiency point	123,1 W
Power consumption in standby mode (P _s)	0,25 W
Nominal power of lighting system	W
Average illumination of the lighting system on the cooking surface	lx
Time increase factor	0,7

EU Conformity declaration

Miele hereby declares that this ceramic induction hob complies with Directive 2014/53/EU.

The complete text of the EU declaration of conformity is available from one of the following internet addresses:

- Products, Download from www.miele.ie
- For service, information, operating instructions etc: go to <https://miele.ie/manuals> and enter the name of the product or the serial number

UK Conformity declaration

Miele hereby declares that this ceramic induction hob complies with UK Radio Equipment Regulations 2017, as amended.

The complete text of the UK declaration of conformity is available from one of the following internet addresses:

- Products, Download from www.miele.co.uk
- For service, information, operating instructions etc: go to <https://miele.co.uk/manuals> and enter the name of the product or the serial number

This **Statement of Compliance** confirms this Miele product fully complies with the **Product Security and Telecommunications Infrastructure (Security Requirements for Relevant Connectable Products) Regulations 2023**.

- 1) Household Appliance – *Induction hobs ICE07-01W*
- 2) Manufactured by: Miele & Cie KG,
Carl Miele Street 29, 33332 Gutersloh Germany
Imported by and contact point: Miele Company Ltd, Fairacres, Marcham Road,
Abingdon, Oxon, OX14 ITW Great Britain
- 3) The defined support period at the time of first supply is 10 years
- 4) To report vulnerabilities and cybersecurity issues please contact: psirt@miele.com
- 5) Signature 
Name: **Paul Wright**
Company Position: **Head of Technical Management**
Date of signature: **19th March 2024**
Place of signature: **Abingdon, Oxfordshire**

United Kingdom

Miele Co. Ltd., Fairacres, Marcham Road, Abingdon, Oxon, OX14 1TW
Tel: 0330 160 6600, Internet: www.miele.co.uk, E-mail: info@miele.co.uk

Australia

Miele Australia Pty. Ltd.
ACN 005 635 398
ABN 96 005 635 398
Level 4, 141 Camberwell Road
Hawthorn East, VIC 3123
Tel: 1300 464 353
E-mail: info@miele.com.au
Internet: www.miele.com.au

China Mainland

Miele Electrical Appliances Co. Ltd.
No. 82, Shimenyi Road, JingAn District
Shanghai, China, P.R.C
Post Code: 200040
Phone: +86 21 6157 3500
Fax: +86 21 6157 3511
E-mail: info@miele.cn
Internet: www.miele.cn

Hong Kong, China

Miele (Hong Kong) Ltd.
41/F - 4101, Manhattan Place
23 Wang Tai Road
Kowloon Bay, Hong Kong
Tel: (852) 2610 1025
Fax: (852) 3579 1404
E-mail:
customerservices@miele.com.hk
Website: www.miele.hk

India

Miele India Pvt. Ltd.
1st Floor, Copia Corporate Suites,
Commercial Plot 9, Mathura Road,
Jasola, New Delhi - 110025
E-mail: customercare@miele.in
Website: www.miele.in

Ireland

Miele Ireland Ltd.
2024 Bianconi Avenue
Citywest Business Campus
Dublin 24
Tel: (01) 461 07 10
Fax: (01) 461 07 97
E-mail: info@miele.ie
Internet: www.miele.ie

Malaysia

Miele Sdn Bhd
Suite 12-2, Level 12
Menara Sapura Kencana
Petroleum
Solaris Dutamas No. 1
Jalan Dutamas 1
50480 Kuala Lumpur, Malaysia
Phone: +603-6209-0288
Fax: +603-6205-3768

New Zealand

Miele New Zealand Limited
IRD 98 463 631
8 College Hill
Freemans Bay, Auckland 1011
Tel: 0800 464 353
E-mail: customercare@miele.co.nz
Internet: www.miele.co.nz

Singapore

Miele Pte. Ltd.
29 Media Circle
#11-04 ALICE@Mediapolis
Singapore 138565
Tel: +65 6735 1191
Fax: +65 6735 1161
E-mail: info@miele.com.sg
Internet: www.miele.sg

South Africa

Miele (Pty) Ltd.
63 Peter Place, Bryanston 2194
P.O. Box 69434, Bryanston 2021
Tel: (011) 875 9000
Fax: (011) 875 9035
E-mail: info@miele.co.za
Internet: www.miele.co.za

Thailand

Miele Appliances Ltd.
BHIRAJ TOWER at EmQuartier
43rd Floor Unit 4301-4303
689 Sukhumvit Road
North Klongton Sub-District
Vadhana District
Bangkok 10110, Thailand

United Arab Emirates

Miele Appliances Ltd.
Showroom 1, Eiffel 1 Building
Sheikh Zayed Road, Umm Al Sheif
P.O. Box 114782 - Dubai
Tel. +971 4 3044 999
Fax. +971 4 3418 852
800-MIELE (64353)
E-mail: info@miele.ae
Website: www.miele.ae

Manufacturer: Miele & Cie. KG, Carl-Miele-Straße 29, 33332 Gütersloh, Germany

KMDA 7676 FL-A, KMDA 7676 FL-U

en-GB

M.-Nr. 12 536 851 / 01 / 002