

Operating and installation instructions Gas hobs

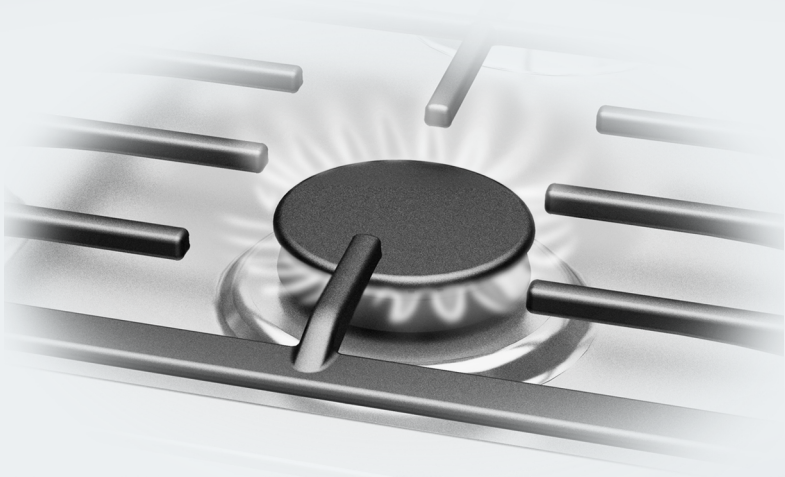

To avoid the risk of accidents or damage to the appliance it is **essential** to read these instructions before it is installed and used for the first time.

This appliance can be used in countries other than those specified on the appliance and in these operating and installation instructions. It is, however, set up for connection to the gas and electricity supplies in the countries specified. For trouble-free operation of the appliance, it is best to use it in the countries specified for use.

Safety precautions to take if you smell gas

- Turn off the gas emergency control valve immediately.
This is usually located near the gas meter.
- Eliminate all sources of ignition in a safe manner.
Do not smoke, light cigarette lighters or matches.
- Do not operate electrical lights or switches, i.e. do not switch them “On” or “Off”.
- Open all doors and windows to ventilate the area.
- If the smell of gas persists, evacuate the building.

Contents

Warning and Safety instructions	6
Caring for the environment	16
Guide to the appliance	17
Hob.....	17
KM 2010, KM 2011	17
KM 2012, KM 2013	18
KM 2030.....	19
KM 2032, KM 2033	20
KM 2050, KM 2051	21
Control knobs.....	22
Burner.....	23
Accessories supplied	24
Before using for the first time	25
Cleaning the hob for the first time.....	25
Switching on the hob for the first time	25
Pans	26
Tips on saving energy	28
Operation	29
Switching on.....	29
Adjusting the flame.....	30
Switching off.....	30
Safety features	31
Cleaning and care	32
Cleaning the stainless steel trough	33
Cleaning the trivets.....	34
Cleaning the control knobs	34
Cleaning the burners.....	35
Assembling the burners	36
Problem solving guide	37
Optional accessories	39
After sales service	40
Contact in case of malfunction	40
Data plate	40
Guarantee.....	40

Installation	41
Safety instructions for installation	41
Safety distances.....	42
Installation notes	45
Building-in dimensions	46
KM 2010, KM 2011, KM 2012, KM 2013	46
KM 2030.....	47
KM 2032, KM 2033	48
KM 2050, KM 2051	49
Installation	50
Gas connection	52
Burner ratings.....	54
Electrical connection.....	56
Converting to another gas type	57
Jet table.....	57
Changing the jets	57
Changing the small jets	59
Functional check	60

Warning and Safety instructions

This hob complies with all relevant local and national safety requirements. Inappropriate use can, however, lead to personal injury and material damage.

Read the operating and installation instructions carefully before using the hob. They contain important information on safety, installation, use and maintenance. This prevents both personal injury and damage to the hob.

Miele expressly and strongly advises that you read and follow the instructions in the chapter on installing the hob as well as the safety instructions and warnings.

Miele cannot be held liable for injury or damage caused by non-compliance with these instructions.

Keep these instructions in a safe place and pass them on to any future owner.

Correct application

- ▶ This hob is intended for domestic use and use in other similar environments.
- ▶ This hob is not intended for outdoor use.
- ▶ It is intended for domestic use only to cook food and keep it warm. Any other use is not supported by the manufacturer and could be dangerous.
- ▶ This hob is not intended for use by people with reduced physical, sensory or mental capabilities or lack of experience and knowledge, unless they have been given supervision and instruction concerning its use by a person responsible for their safety. They may only use the hob unsupervised if they have been shown how to use it in a safe way. They must be able to recognise and understand the dangers of misuse.

Warning and Safety instructions

Safety with children

- ▶ Children under 8 years of age must be kept away from the hob unless they are constantly supervised.
- ▶ Children over 8 years of age may use the hob without supervision if its operation has been clearly explained to them and they are able to use it safely. Children must be able to understand and recognise the possible dangers caused by incorrect operation.
- ▶ Children must not be allowed to clean the hob unsupervised.
- ▶ Please supervise children in the vicinity of the hob and do not let them play with it.
- ▶ The hob gets hot when in use and remains hot for a while after being switched off. Keep children well away from the hob until it has cooled down and there is no danger of burning.
- ▶ Danger of burning. Do not store anything which might arouse a child's interest in storage areas above or behind the hob. Otherwise they could be tempted to climb onto the hob.
- ▶ Risk of burning and scalding. Place pots and pans on the cooking zone in such a way that children cannot pull them down and burn themselves.
- ▶ Danger of suffocation. Packaging, e.g. plastic wrappings, must be kept out of the reach of babies and children. Whilst playing, children could become entangled in packaging or pull it over their head and suffocate.

Technical safety

- ▶ Unauthorised installation, maintenance and repairs can cause considerable danger for the user. Installation, maintenance and repairs must only be carried out by your Miele dealer.
- ▶ Damage to the hob can compromise your safety. Check the hob for visible signs of damage. Do not use the hob if it is damaged.
- ▶ Temporary or permanent operation on an autonomous power supply system or a power supply system that is not synchronised with the mains power supply (e.g. island networks, back-up systems) is possible. A prerequisite for operation is that the power supply system complies with the specifications of EN 50160 or an equivalent standard.

The function and operation of the protective measures provided in the domestic electrical installation and in this Miele product must also be maintained in isolated operation or in operation that is not synchronised with the mains power supply, or these measures must be replaced by equivalent measures in the installation. As described, for example, in the current version of BS OHSAS 18001–2 ISO 45001.

- ▶ The electrical safety of this hob can only be guaranteed when correctly earthed. It is essential that this standard safety requirement is met. If in any doubt please have the electrical installation tested by a qualified electrician.
- ▶ To avoid the risk of damage to the hob, make sure that the connection data on the data plate (voltage and frequency) match the mains electricity supply before connecting it to the mains. Consult a qualified electrician if in doubt.
- ▶ Do not connect the hob to the mains electrical supply by a multi-socket adapter or extension lead. These are a fire hazard and do not guarantee the required safety of the appliance.
- ▶ For safety reasons, this hob may only be used after it has been built in.

Warning and Safety instructions

- ▶ This hob must not be used in a non-stationary location (e.g. on a ship).
- ▶ Never open the casing of the hob.
Touching or tampering with electrical connections or components and mechanical parts is highly dangerous to the user and can cause operational faults.
- ▶ While the hob is under warranty, repairs should only be undertaken by your Miele dealer. Otherwise the warranty is invalidated.
- ▶ Miele can only guarantee the safety of the appliance when genuine original Miele replacement parts are used. Faulty components must only be replaced by Miele spare parts.
- ▶ The hob is not intended for use with an external timer switch or a remote control system.
- ▶ The connection to the gas supply must be carried out by a suitably qualified gas fitter (see “Installation – Gas connection”).
If the plug has been removed from the connection cable or the connection cable is not supplied with a plug, the hob must be connected to the electricity supply by a suitably qualified electrician (see “Installation – Electrical connection”).
- ▶ If the mains connection cable is damaged, it must be replaced with a special mains connection cable by a qualified electrician (see “Electrical connection” in the “Installation” chapter).

Warning and Safety instructions

▶ During installation, maintenance and repair work, the hob must be disconnected from the mains electricity supply. The gas supply must also be shut off. Depending on country this is done in one of several different ways:

- the mains fuse has been disconnected, or
- the screw-out fuse is removed (in countries where this is applicable), or
- switch off at the wall socket and withdraw the plug from the socket. Pull by the plug and not by the mains connection cable to disconnect from the mains electricity supply.
- the gas inlet valve is closed.

▶ Danger of electric shock!

Do not use the hob if it is damaged or if it suffers damage during use. Switch it off immediately. Disconnect it from the mains electricity and gas supply. Call your Miele dealer.

▶ If the hob is installed behind a cabinet door, do not close the door while the hob is in use. Heat and moisture can build up behind the closed door. This can result in damage to the hob, the housing unit and the floor. Leave the furniture door open until the hob has cooled down completely.

Warning and Safety instructions

Correct use

- ▶ The hob gets hot when in use and remains hot for some time after being switched off. Do not touch the hob if there is a possibility that it could still be hot.
- ▶ Due to the high temperatures radiated, objects left near the hob when it is in use could catch fire.
Do not use the hob to heat up the room.
- ▶ Oil and fat can overheat and catch fire. Do not leave the hob unattended when cooking with oil and fat. If it does ignite do not attempt to put the flames out with water.
Disconnect the hob from the mains and use a suitable fire blanket, saucepan lid, damp towel or similar to smother the flames.
- ▶ Do not leave the hob unattended whilst it is being used. It should be continually monitored whilst boiling and flash frying.
- ▶ Flames could set the grease filters of a cooker hood on fire. Do not flambé under a cooker hood.
- ▶ Spray canisters, aerosols and other inflammable substances can ignite when heated. Therefore do not store such items or substances in a drawer under the hob. Cutlery inserts must be heat-resistant.
- ▶ Do not heat an empty pan.
- ▶ Do not heat up food in closed containers e.g. tins or sealed jars on the hob, as pressure can build up in the container, causing it to explode.
- ▶ Do not cover the hob, e.g. with a hob cover, a cloth or protective foil. The material could catch fire, shatter or melt if the hob is switched on by mistake or if residual heat is still present.
- ▶ If the appliance is switched on by mistake, or if there is residual heat present, there is the risk of any metal items placed on the hob heating up. Other materials can melt or catch fire. Do not use the appliance as a resting place for anything.

Warning and Safety instructions

- ▶ You could burn yourself on the hot hob. Protect your hands with heat-resistant pot holders or gloves when handling hot pots and pans. Do not let them get wet or damp, as this causes heat to transfer through the material more quickly with the risk of scalding or burning yourself on steam. Be sure to keep all textiles away from the gas flames. Do not use oversized cloths, tea towels or other similar materials.
- ▶ When using an electrical appliance, e.g. a hand-held food blender, near the hob, ensure that the cable of the electrical appliance cannot come into contact with the hot hob. The insulation on the cable could become damaged.
- ▶ Plastic and aluminium foil containers melt at high temperatures. Do not use plastic or aluminium foil containers.
- ▶ When a control knob is pressed down, a spark is generated on the ignitor. Do not press down the control knob while you are cleaning or touching the hob or a burner in the vicinity of an ignitor.
- ▶ If a cooker hood is installed above the hob, ensure that the burners are always covered with a pan when in use. Otherwise flames could reach the cooker hood, parts of which could then be damaged or even set on fire.
- ▶ Only light the gas burners after all burner parts have been properly assembled.
- ▶ Pans must be the correct size for the burner they are used on (see “Pans”). A pan which is too small will be unstable on the pan support. If the pan diameter is too large, flames can spread out to the sides and damage or burn the worktop, wall claddings or surrounding units and also parts of the hob. Miele cannot be held liable for this type of damage.
- ▶ Ensure that the flames from the burner do not spread out beyond the base and up the sides of the pan.

Warning and Safety instructions

- ▶ Do not use pans with very thin bases on this hob, and never heat up empty pans as they could get damaged. This could also damage the appliance.
- ▶ The pan support supplied with the appliance must always be used. Never place a pan on the burner itself.
- ▶ Replace the pan supports carefully to avoid scratching the surface.
- ▶ Do not use or store flammable materials near this hob.
- ▶ Remove splashes of fat and other food debris from the surface of the hob as soon as possible. These are a fire hazard.
- ▶ Avoid allowing liquids or foods containing salt to spill onto the hob. If salty foods or liquids do get on the hob, they should be removed as soon as possible to avoid the risk of corrosion.
- ▶ Using the hob will cause a build-up of heat and moisture in the room in which it is installed. Ensure that the room has sufficient natural or mechanical means of ventilation, e.g. a cooker hood.
- ▶ If the hob is used for very long periods of time, additional ventilation of the room may be necessary, e.g. by opening windows or doors, or running the cooker hood on the highest setting.
- ▶ Do not use roasting dishes, pans or grilling stones that are large enough to cover more than one burner. The resulting build-up of heat could damage the hob.
- ▶ If the hob has not been used for a long period of time it should be thoroughly cleaned before it is used again. It is also advisable to have the appliance tested by a qualified person for safety.

Cleaning and care

- ▶ Do not use a steam cleaning appliance to clean this hob. The steam could reach electrical components and cause a short circuit.
- ▶ Miele will guarantee to supply functional spare parts for a minimum of 10 years and up to 15 years following the discontinuation of your hob.

Caring for the environment

Disposing of the packaging material

The packaging material is used for handling and protects the appliance from transport damage. The packaging material used is selected from materials which are environmentally friendly for disposal and can generally be recycled.

Recycling the packaging material reduces the use of raw materials. Use material-specific collection points for valuable materials and take advantage of return options. Your Miele dealer will take the packaging material away.

Disposal of your old appliance

Electrical and electronic appliances often contain valuable materials. They also contain materials which, if handled or disposed of incorrectly, could be potentially hazardous to human health and to the environment. They are, however, essential for the correct functioning of your appliance. Please do not therefore dispose of it with your household waste.

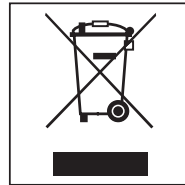

Please dispose of it at your local community waste collection / recycling centre or contact your Miele dealer for advice.

Ensure that it presents no danger to children while being stored for disposal.

Hob

KM 2010, KM 2011

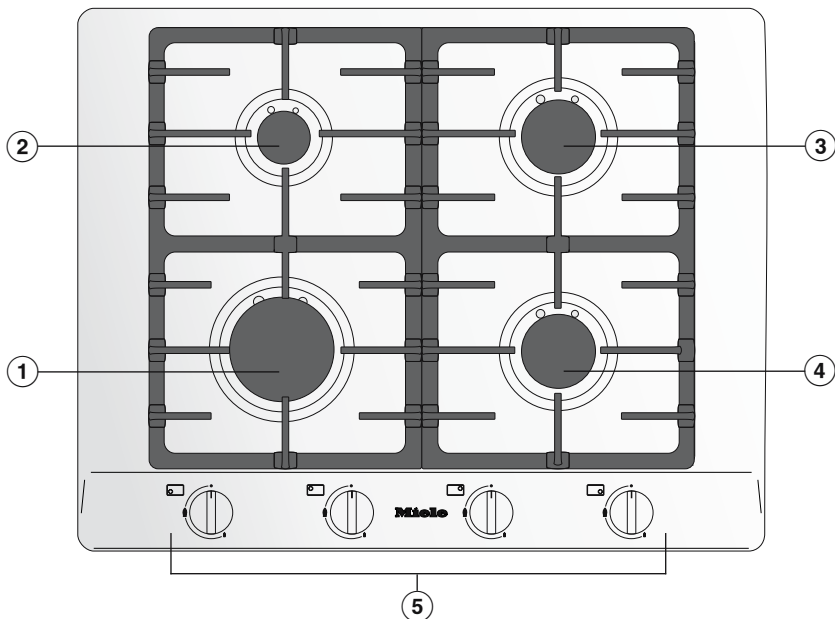

- ① Large burner
- ② Small burner
- ③ Medium burner
- ④ Medium burner
- ⑤ Rotary control for burners

Guide to the appliance

KM 2012, KM 2013

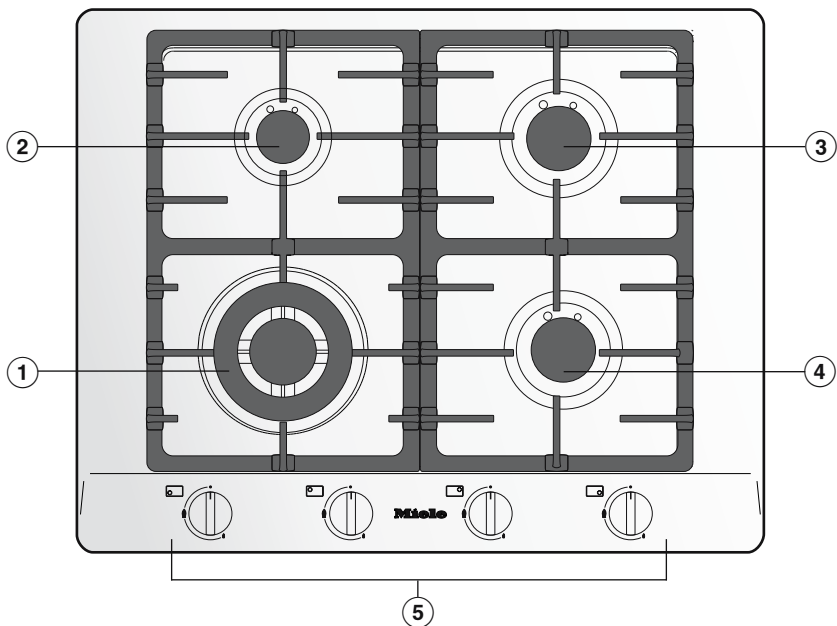

- ① Wok burner
- ② Small burner
- ③ Medium burner
- ④ Medium burner
- ⑤ Rotary control for burners

KM 2030

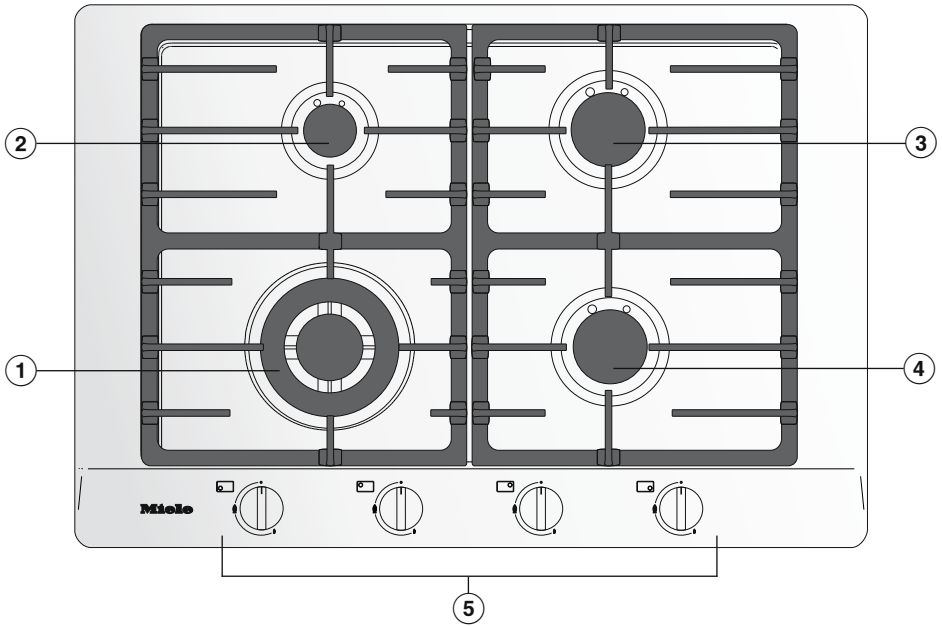

- ① Wok burner
- ② Small burner
- ③ Medium burner
- ④ Medium burner
- ⑤ Rotary control for burners

Guide to the appliance

KM 2032, KM 2033

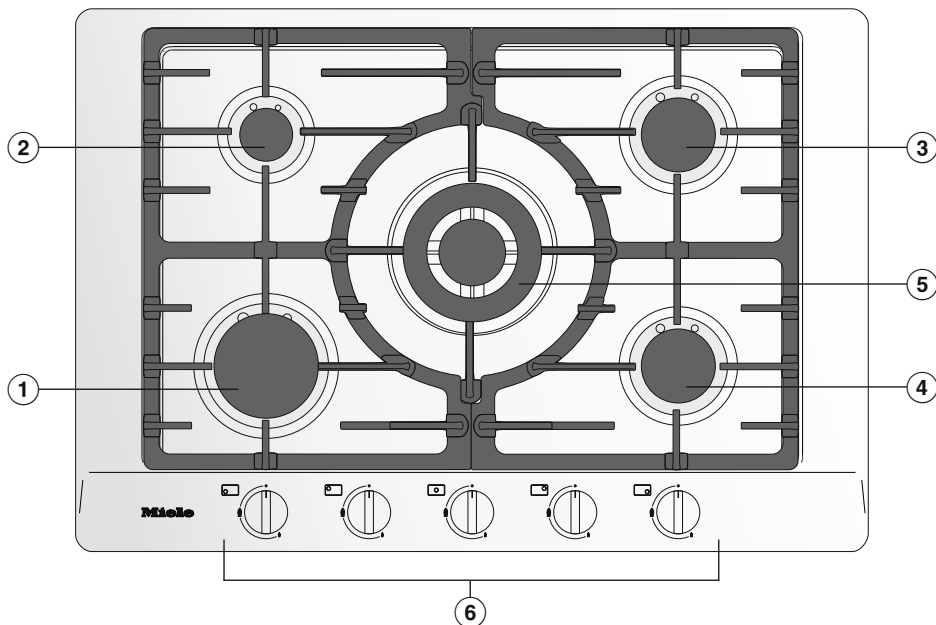

- ① Large burner
- ② Small burner
- ③ Medium burner
- ④ Medium burner
- ⑤ Wok burner
- ⑥ Rotary control for burners

KM 2050, KM 2051

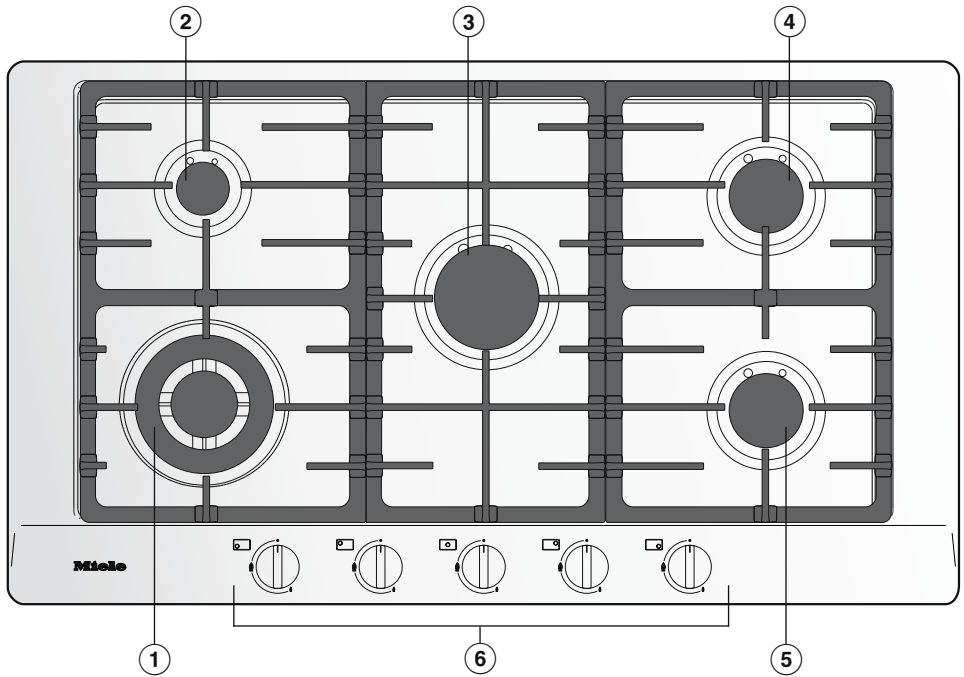

- ① Wok burner
- ② Small burner
- ③ Large burner
- ④ Medium burner
- ⑤ Medium burner
- ⑥ Rotary control for burners

Guide to the appliance

Control knobs

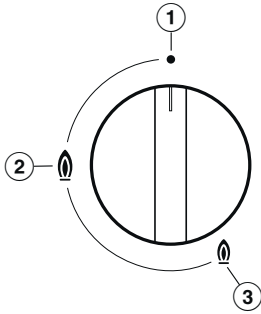

- ① • Burner off
The gas supply is turned off
- ② 🔥 Strong flame
The burner is on the highest setting
- ③ 🔥 Weak flame
The burner is on the lowest setting

Burner

Wok burner

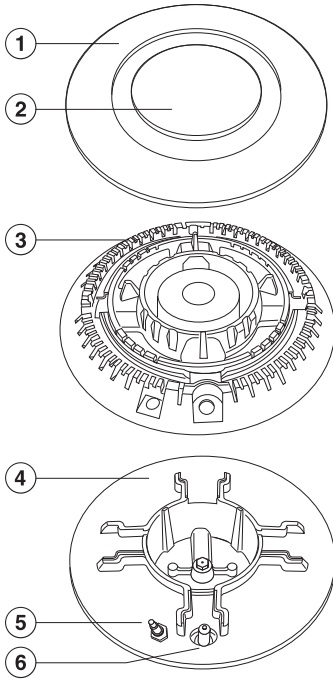

- ① Outer burner cap
- ② Inner burner cap
- ③ Burner head
- ④ Burner base
- ⑤ Thermocouple
- ⑥ Ignition electrode

Small, medium and large burners

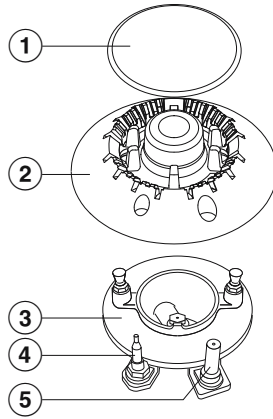

- ① Burner cap
- ② Burner head
- ③ Burner base
- ④ Thermocouple
- ⑤ Ignition electrode

Guide to the appliance

Accessories supplied

The accessories supplied with your appliance as well as a range of optional ones are available to order from your Miele dealer (see „Optional accessories“).

Wok ring



The wok ring supplied gives additional stability to the wok, especially to woks with a rounded base.

- Please stick the extra data plate for the appliance supplied with this documentation in the space provided in the “After sales service” section of this booklet.
- Remove any protective wrapping and stickers.

Cleaning the hob for the first time

- Before using for the first time, clean the hob with a damp cloth only and then wipe dry.
- Clean all removable parts of the burners with a solution of warm water and a small amount of washing-up liquid applied with a soft sponge. Dry all parts thoroughly after cleaning and then reassemble the burners (see “Cleaning and care”).

Switching on the hob for the first time

The metal components have a protective coating. When the hob is used for the first time, this causes a smell and possibly also vapour.

The smell and any vapours given off do not indicate a faulty connection or appliance and they are not hazardous to health.

Pans

Minimum cookware base diameter [cm]	
Small burner	10
Medium burner	12
Large burner	14
Wok burner	24

Maximum diameter at top of cookware [cm]	
Small burner	22
Medium burner	22
Large burner	24
Wok burner pots/pans	24
Wok burner wok pan	40

- Select the pan to suit the size of the burner:
large diameter = large burner
small diameter = small burner.
- Observe the dimensions given in the chart. Using pans that are too large can cause the flames to spread out and damage the surrounding worktop or other appliances. Using pans of the correct size improves efficiency. Pans that are smaller than the pot rests and pans that do not stand safely (without wobbling) on the pot rests are dangerous and should not be used.
- A wok burner is particularly suitable for wok pans. Make sure that the base of the wok pan does not touch the burner. A minimum distance of 1 cm should be maintained between the burner and the base of the wok pan above it.
- In contrast to pans for use on electric hobs, the bases of pans for use on gas hobs do not need to be flat to achieve good results.
- Remember when purchasing new pans that manufacturers usually refer to the diameter at the top of the pan in their documentation, and not to the base diameter.
- You can use any cookware that is heat-resistant.
- Cookware with a thick base is preferable as the heat is distributed evenly. With thinner based cookware, there is the risk that food will overheat in places. Therefore it should be stirred more frequently.

- Always place the cookware on the pot rests supplied. Do not place cookware directly on the burners.
- Place the cookware on the pot rests in such a way that it cannot tip over. A minor wobble can never be completely excluded.
- Do not use pots or pans with an edge-supported base.



Wok ring

- Use the wok ring supplied to give additional stability to pans, especially to woks with a rounded base.

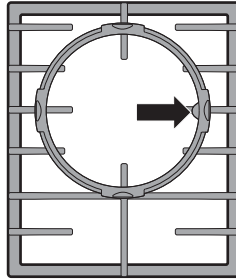

- Place the wok ring on the pan support so that it sits securely in position and cannot move (see diagram).

Tips on saving energy

- Use a pan lid whenever possible to minimize heat loss.

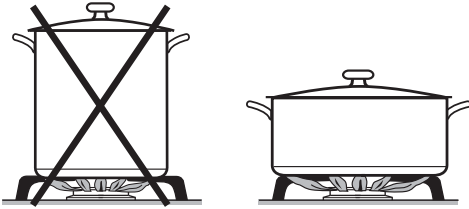

- Wide, shallow pans are preferable to tall, narrow ones. They will heat up faster.
- Cook with as little water as possible.
- Reduce the size of the flame once the water has come to the boil or the oil is hot enough to fry in.
- Use a pressure cooker to reduce cooking times.

 Risk of fire with overheated food. Unattended food can overheat and catch alight. Do not leave the hob unattended whilst it is being used.

Switching on

- Press in the relevant rotary control and turn it anti-clockwise to the large flame symbol. The ignition electrode will “click” and ignite the gas.

When the rotary control is operated, a spark is automatically produced on all burners. This is normal and does not indicate a fault.

- When a flame is visible, keep the rotary control pressed down for 5–10 seconds, and then let it go.
- If the burner does not ignite, turn the rotary control to • burner off. Ventilate the room or wait for at least 1 minute before trying again. When making another ignition attempt, it may be necessary to hold the rotary control for longer.
- If the burner does not ignite the second time, turn the rotary control back to • burner off and see “Problem solving guide”.

Switching on during a power outage

If there is an interruption to the electricity supply, the gas can be ignited manually, e.g. with a match.

- Press in the relevant control and turn it anti-clockwise to the large flame symbol.
- Hold the control pressed in and light the gas at the burner with a match.
- Keep the control pressed in for a further 5-10 seconds and then release it.

Operation

Adjusting the flame

The burners can be regulated at any level between the strongest and weakest flame.

As the outer part of the flame is much hotter than the centre, the tips of the flames should stay beneath the pan base. Flame tips which extend beyond the sides of the pan merely warm up the air in the room and can also damage pan handles and increase the danger of injury.

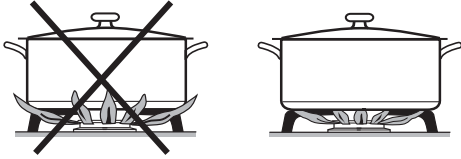

- Adjust the flame so that it does not spread out beyond the sides of the pan.

Switching off

- Turn the rotary control clockwise to
 - burner off.

The gas supply is cut off and the flame goes out.

Thermo-electric ignition safety device

Your hob is equipped with a thermo-electric ignition safety device. If a gas flame is extinguished, e.g. by food boiling over or by a draught, the gas supply is switched off. This prevents the release of gas. If you turn the rotary control to • burner off, the burner is ready for use again.

The thermo-electric ignition safety device operates independently from the electricity supply. This means that it will still work if the hob is used during a power cut.

Cleaning and care

 Danger of burning due to hot surfaces.

The hob surface, pan supports and burners will be hot after use.

Allow the hob to cool down before cleaning it.

 Risk of damage due to moisture ingress.

The steam from a steam cleaning appliance could reach live electrical components and cause a short circuit.

Do not use a steam cleaner to clean the hob.

All surfaces could be discoloured or damaged if unsuitable cleaning agents are used. All surfaces are susceptible to scratching.

Remove all cleaning agent residues immediately.

Never use abrasive sponges or cleaning agents.

Food boiling over can cause discoloration of the burner components.

Remove any soiling and salt and sugar splashes immediately.

When a control knob is pressed down, a spark is generated on the ignitor. Do not press down the control knob while you are cleaning or touching the hob or a burner in the vicinity of an ignitor.

Unsuitable cleaning agents

To avoid damaging the surfaces of the appliance, do not use:

- cleaning agents containing soda, alkalines, ammonia, acids or chlorides
- cleaning agents containing descaling agents
- stain and rust removers
- abrasive cleaning agents, e.g. powder cleaners and cream cleaners
- solvent-based cleaning agents
- dishwasher cleaner
- oven sprays
- glass cleaning agents
- hard, abrasive brushes or sponges (e.g. pot scourers), or sponges which have been previously used and still contain abrasive cleaning agents
- melamine eraser blocks

- The entire hob should be cleaned after each use.
- Soften any stubborn soiling beforehand.
- Dry the hob thoroughly after every damp cleaning to avoid limescale residue.

Cleaning the stainless steel trough

 Risk of damage by pointed objects.

The seal between the hob and the worktop could suffer damage.

Do not use pointed objects for cleaning.

 Damage caused by soiling.

Soiling, particularly salty food or liquid and olive oil, can cause damage if left on the printed surfaces for a long time.

Remove such soiling immediately.

 Damage caused by incorrect cleaning.

Stainless steel cleaning agents rub off the printed symbols.

Do not use stainless steel cleaning agents on printed symbols.

- Clean stainless steel surfaces using a solution of warm water and a little washing-up liquid applied with a soft sponge. Soften any stubborn soiling beforehand. If necessary, the rough side of a non-scouring sponge can be used.
- Finally, dry with a clean soft cloth.

Cleaning and care

Cleaning the trivets

- Remove the trivets.
- Clean the trivets in a dishwasher or with a solution of warm water and a little washing-up liquid applied with a soft sponge. Soften any stubborn soiling beforehand.
- Dry the trivets thoroughly with a clean cloth.

Cleaning the control knobs

The control knobs are not dishwasher-safe. The control knobs should only be cleaned by hand.

The rotary controls can become discoloured if they are not cleaned regularly. Clean the control knobs after each use.

- Clean the control knobs using a solution of warm water and a little washing-up liquid applied with a soft sponge.

Cleaning the burners

Do not clean any parts of the burners in a dishwasher.

The surface of the burner cap will become duller with time. This is completely normal and does not indicate material deterioration.

- The burner should be dismantled and then cleaned by hand using a solution of warm water and a little washing-up liquid applied with a soft sponge.
- Clean any soiling from the flame openings.



Danger of explosion.

Blocked flame openings can cause a dangerous build-up of gas in the base of the hob which could ignite and cause an explosion. This can lead to damage to the appliance and injury.

Ensure the flame openings are kept clean at all times.

- Parts of the burner that cannot be removed should be wiped clean with a damp cloth only.
- The ignitor and thermocouple should be very carefully wiped clean using a well wrung-out cloth.

The ignitor must not get wet, otherwise it will not spark.

- Finally dry everything thoroughly with a clean cloth. Make sure that the flame openings are completely dry.

The burner cap has a PerfectClean treated surface with excellent non-stick properties which make cleaning easier.

Cleaning and care

Assembling the burners

Assembling the small, medium and large burners

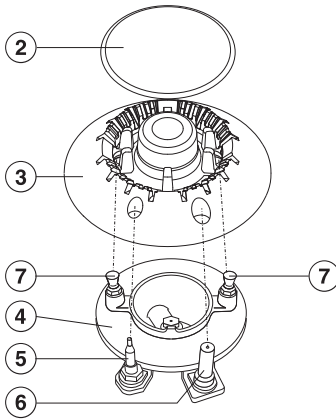

- Place the burner head ③ onto the burner base ④ so that the thermocouple ⑤, the ignitor ⑥ and the retaining pins ⑦ fit into their respective holes in the burner head.
- Position the burner cap ② onto the burner head ③ so that the retaining pins fit into their respective recesses. Gently twist the burner cap clockwise or anti-clockwise until it locks into position. When correctly positioned, the burner cap will not slide about.

Ensure parts are reassembled in the correct order.

Assembling the wok burner

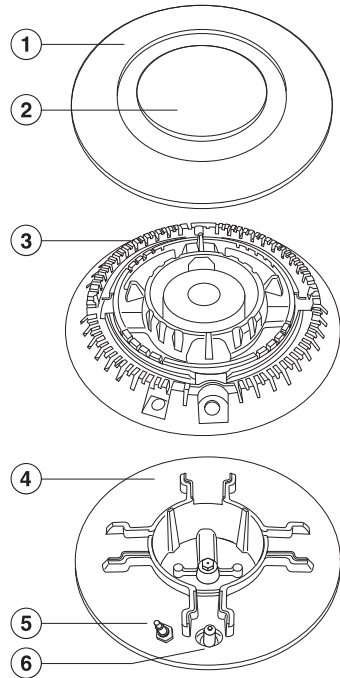

Functional check

- Ignite all burners to check that they are burning correctly:
 - The flame must not go out on the lowest setting, or when the control is turned quickly from the highest to the lowest setting.
 - On the highest setting, the flame must have a distinctive and visible core.

Problem solving guide

Many malfunctions and faults that can occur in daily operation can be easily remedied. You can save time and money in many cases, as you do not need to call the the Miele Dealer.

The following tables are designed to help you to find the cause of a malfunction or a fault and to resolve it.

Issue	Cause and remedy
The burners do not ignite when the hob is being used for the first time or after it has been out of use for a longer period.	<p>There could be an air lock in the gas pipe.</p> <ul style="list-style-type: none"> ■ You may need to make several attempts before the burner ignites successfully.
The burner does not light after several attempts.	<p>There is a technical fault.</p> <ul style="list-style-type: none"> ■ Turn all of the rotary controls clockwise to • burner off and interrupt the power supply to the hob for a few seconds.
	<p>The burner is not correctly assembled.</p> <ul style="list-style-type: none"> ■ Assemble the burner correctly.
	<p>The gas shut-off device has not been opened.</p> <ul style="list-style-type: none"> ■ Open the gas shut-off device.
	<p>The burner is wet and/or dirty.</p> <ul style="list-style-type: none"> ■ Clean and dry the burner.
	<p>The flame openings are blocked and/or wet.</p> <ul style="list-style-type: none"> ■ Clean and dry the flame openings.
The gas flame goes out after ignition.	<p>The flames do not touch the thermocouple and the burner does not get hot enough: The burner parts are not positioned correctly.</p> <ul style="list-style-type: none"> ■ Assemble the burner components correctly.
	<p>The thermocouple is dirty.</p> <ul style="list-style-type: none"> ■ Remove any soiling.
The flame suddenly looks different.	<p>The burner parts are not positioned correctly.</p> <ul style="list-style-type: none"> ■ Position the burner parts correctly.
	<p>The burner head or the holes in the burner cap are dirty.</p> <ul style="list-style-type: none"> ■ Remove any soiling.

Problem solving guide

Issue	Cause and remedy
The gas flame goes out during use.	The burner parts are not positioned correctly. ■ Position the burner parts correctly.
The electronic ignition device on the burner is not working.	The mains fuse has tripped. ■ If necessary, contact your Miele dealer for assistance.
	There is food residue stuck between the ignitor and the burner cap. The thermocouple is dirty. ■ Remove any soiling (See “Cleaning and care”).

Miele offer a comprehensive range of useful accessories as well as cleaning and conditioning products for your Miele appliances.

These can be ordered from your Miele dealer (see end of this booklet for contact details).

Ceramic and stainless steel hob cleaner 250 ml

Removes heavy soiling, limescale deposits and aluminium residues.

Microfibre cloth

For removing finger marks and light soiling.

After sales service

Contact in case of malfunction

In the event of any faults which you cannot remedy yourself, please contact your Miele dealer.

Contact details for your Miele dealer are given at the end of this document.

Please note that telephone calls may be monitored and recorded for training purposes and that a call-out charge will be applied to service visits where the problem could have been resolved as described in this booklet.

Please quote the model and serial number of your appliance when contacting your Miele dealer. This information can be found on the data plate.

Data plate

Stick the extra data plate supplied with the appliance here. Make sure that the model number matches the one specified on the back cover of this document.



Guarantee

For information on the appliance guarantee specific to your country please contact your Miele dealer. See end of this booklet for contact details.

Safety instructions for installation

 Risk of damage from incorrect connection.
Incorrect installation can cause damage to the hob.
The hob must only be installed by a qualified person.

 Damage from falling objects.
Take care not to damage the hob when fitting wall units or a cooker hood above it.
Fit the wall units and the cooker hood before the hob.

- ▶ The room in which the hob is installed must conform to all relevant local and national building regulations and safety regulations.
- ▶ The veneer or laminate coatings of worktops (or adjacent kitchen units) must be treated with 100 °C heat-resistant adhesive which will not dissolve or distort. Any backmoulds must be of heat-resistant material.
- ▶ The hob must not be installed over a fridge, fridge-freezer, freezer, dishwasher, washing machine, washer-dryer or tumble dryer.
- ▶ A gas hob must not be installed directly next to a deep fat fryer as the gas flames could ignite the fat in the fryer. It is essential to maintain a distance of at least 300 mm between these two appliances.
- ▶ When installing the hob, make sure that the gas pipe and electrical connection cable cannot come into contact with hot appliance parts.
- ▶ The electrical cable and any flexible gas connection pipes must be installed in such a way so that they do not come into contact with any moving kitchen parts (e.g. a drawer), and cannot become trapped.
- ▶ Observe carefully the safety clearances listed on the following pages.

Installation

Safety distances

Safety distance above the hob

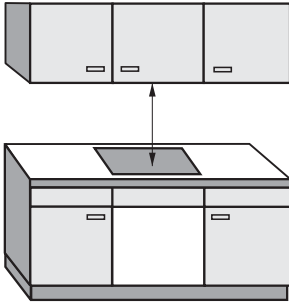

The safety distance specified by the manufacturer of the cooker hood must be maintained between the hob and the cooker hood above it.

If combustible objects are installed above the hob (e.g., cabinets, utensil rail, etc.), a minimum safety distance of 760 mm must be maintained.

When two or more appliances which have different safety distances are installed together below a cooker hood, you should observe the greatest specified safety distance.

Safety distances to the sides and back of the appliance

It is advisable to install the hob with plenty of space either side of it.

The minimum distance ① shown below must be maintained between the back of the hob and a tall unit or wall.

The minimum distance ②, ③ shown below must be maintained between a tall unit or a wall to the left or right of the hob with a minimum distance of 300 mm on the opposite side.

① Minimum distance between the **back** of the worktop cut-out and the rear edge of the worktop:
50 mm

② Minimum distance between the worktop cut-out and a wall or tall unit to the **right** of it:
100 mm.

③ Minimum distance between the worktop cut-out and a wall or tall unit to the **left** of it:
100 mm.

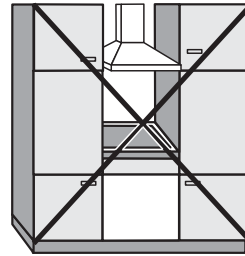

Not allowed

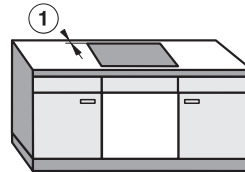
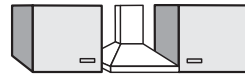

Highly recommended

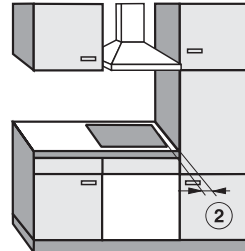

Not recommended

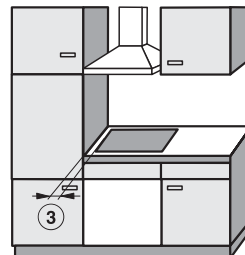

Not recommended

Installation

Safety distance to niche cladding

If niche cladding is installed, a minimum safety distance must be maintained between the worktop cut-out and the cladding, since high temperatures can alter or damage these materials.

If the niche cladding is made from a combustible material (e.g. wood), a minimum safety distance ⑤ of 50 mm must be maintained between the worktop cut-out and the cladding.

If the niche cladding is made from a non-combustible material (e.g. metal, natural stone, ceramic tiles), the minimum safety distance ⑤ between the worktop cut-out and the cladding will be 50 mm minus the thickness of the cladding.

Example: 15 mm thick niche cladding

50 mm – 15 mm = minimum safety distance of 35 mm

Flush-fit installation

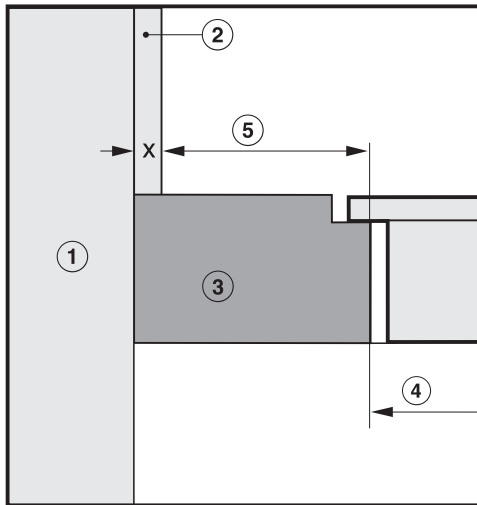

Surface-mounted installation

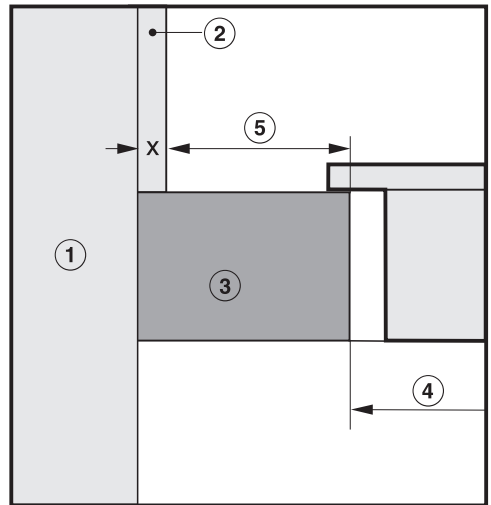

- ① Masonry
- ② Niche cladding dimension x = thickness of the niche cladding material
- ③ Worktop
- ④ Worktop cut-out
- ⑤ Minimum safety distance to
combustible materials 50 mm
non-combustible materials 50 mm – dimension x

Installation notes

Seal between the hob and the worktop

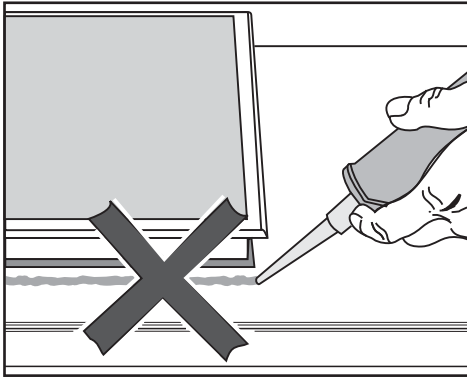

 Damage caused by incorrect installation.

Using sealant under the hob could result in damage to the hob and the worktop if the hob ever needs to be removed for servicing.

Do not use sealant between the hob and the worktop.

The sealing strip under the edge of the hob provides a sufficient seal for the worktop.

Sealing strip

Dismantling the hob for service purposes may damage the sealing strip underneath the edge of the hob.

Always replace the sealing strip before reinstalling the hob.

Tiled worktops

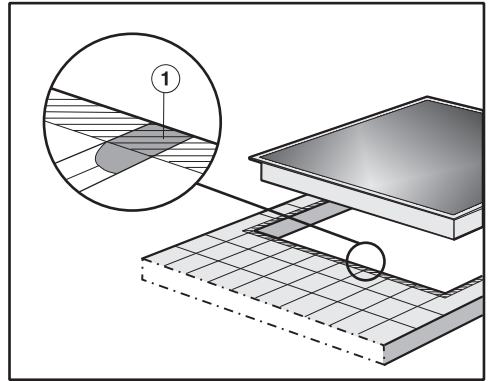

Grout lines ① and the hatched area underneath the hob frame must be smooth and even. If they are not the hob will not sit flush with the worktop and the sealing strip underneath the hob will not provide a good seal between the hob and the worktop.

KM 2030

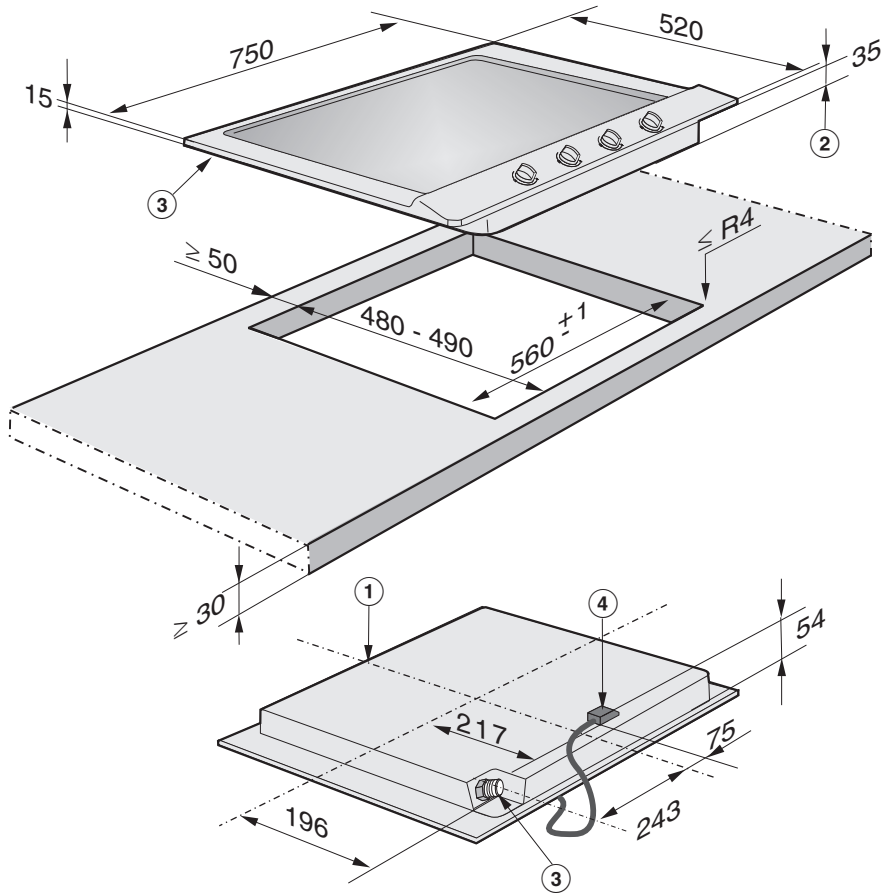

- ① Front
- ② Casing depth
- ③ Gas connection R 1/2" ISO 7-1 (DIN EN 10226)
- ④ Mains connection box with mains connection cable
Mains connection cable L = 2000 mm

Installation

Installation

Preparing the worktop

- Create the worktop cut-out. Remember to maintain the minimum safety distances (see “Installation – Safety distances”).
- Seal any cut surfaces on **wooden worktops** with a special varnish, silicone sealant or resin to prevent the wood from swelling as a result of moisture ingress. The sealant must be heat-resistant.

Make sure that the sealant does not come into contact with the top of the worktop.

The seal under the appliance ensures that the hob will sit securely in the cut-out without slipping. Any gap between the appliance frame and worktop will become smaller over time.

Installing the hob

- Stick the supplied sealing strip under the edge of the hob.
- Feed the power cable for the hob down through the worktop cut-out.
- Place the hob loosely in the cut-out. When doing this, make sure that the seal of the appliance sits flush with the worktop on all sides. This is important to ensure an effective seal all round.

If the seal does not sit flush with the worktop in the corners, the corner radius ($\leq R4$) can be carefully cut to fit using a jigsaw.

Do not use any additional sealant (e.g. silicone) on the hob.

- Connect the hob to the electricity supply (see “Installation – Electrical connection”).
- Connect the hob to the gas supply (see “Installation – Gas connection”).

Securing the hob

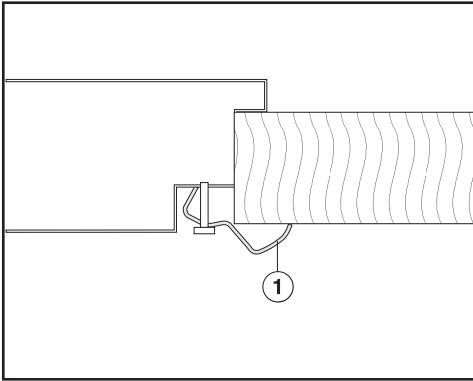

- Secure the hob using the brackets ① supplied.

Functional check

- After installing the hob, ignite all burners to check that they are operating correctly:
 - The flame must not go out on the lowest setting, or when the control is turned quickly from the highest to the lowest setting.
 - On the highest setting, the flame must have a distinctive and visible core.

Installation

Gas connection

 Risk of explosion due to an incorrect gas connection.

If the gas connection is carried out incorrectly, it may result in gas leakage.

Connection to the gas supply must only be undertaken by an approved and registered gas installer in strict accordance with current local and national safety and building regulations. The installer is responsible for ensuring that the appliance functions correctly when installed.

 Risk of explosion due to an incorrect conversion.

If the conversion to another type of gas is carried out incorrectly, it may result in gas leakage.

Conversion from one type of gas to another must only be undertaken by an approved and registered gas installer in strict accordance with current local and national safety and building regulations. The installer is responsible for ensuring that the appliance functions correctly when installed.

The gas connection must be installed so that connection can be made either from inside or outside the kitchen furniture unit. The isolating valve must be easily accessible and visible (by opening the cabinet door if necessary).

Check with your local gas supplier about the type of gas supplied and compare this information with the type of gas quoted on the appliance's data plate.

The hob is not connected to an exhaust flue.

When installing and connecting the appliance please observe all relevant installation instructions and ensure it has adequate ventilation once installed.

The gas connection must be made in accordance with national and local regulations.

Any special local conditions relating to gas installations as well as building regulations must also be observed.

 Risk of heat damage.

Gas connections, pipes and connection cables can suffer damage if exposed to heat from the hob.

After installation make sure that neither the gas pipe nor the mains cable can come into contact with hot parts of the appliance and that the gas pipe and connections on the hob cannot come into contact with hot gas exhaust.

⚠ Risk of explosion due to damaged gas pipes.
Gas can leak from damaged flexible gas pipes.
Attach flexible gas pipes in such a way so that they do not come into contact with any moving kitchen parts (e.g. a drawer) and are not exposed to mechanical stress.

Connect the hob to the gas supply in accordance with national and local regulations. Check the gas connection for any leaks.

Depending on country of destination this appliance is set up for connection to natural or liquid gas. See adhesive label on the appliance.

Depending on country of destination, jets are supplied for conversion to a different type of gas. If the appropriate jets have not been supplied with the appliance, you will need to contact your Miele dealer. Conversion to another type of gas is described in the section "Converting to another type of gas".

Connecting the hob

The hob is supplied with a conical $\frac{1}{2}$ " gas connection point. There are two connection options:

- Fixed connection
- Flexible connection, maximum length 2000 mm.

⚠ Risk of explosion due to gas leakage.
Unsuitable sealant will not ensure the required leak protection for connections.
Ensure that a suitable sealant is used.

Using a 90° angle

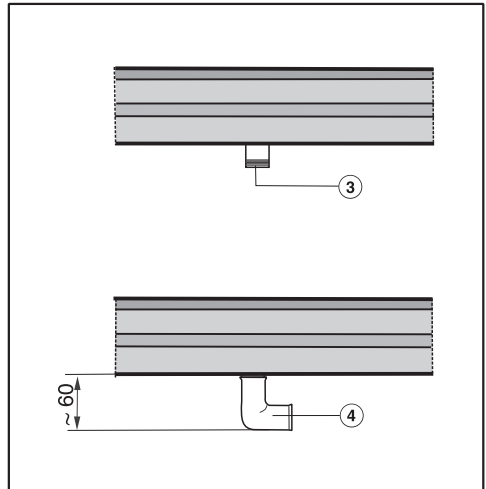

③ Connection R $\frac{1}{2}$ "

④ 90° elbow

The installation height in the area of the gas connection is increased by approx. 60 mm.

Installation

Burner ratings

Nominal ratings for KM 2010, KM 2011

Burner	Gas type	Highest setting		Lowest setting
		kW	g/h	kW
Small burner	Natural gas H	1.0	–	0.25
	Liquid gas	1.0	73	0.25
Medium burner	Natural gas H	1.75	–	0.35
	Liquid gas	1.75	127	0.35
Large burner	Natural gas H	2.6	–	0.5
	Liquid gas	2.6	189	0.6
Total	Natural gas H	7.1	–	
	Liquid gas	7.1	517	

Nominal ratings for KM 2012, KM 2013, KM 2030

Burner	Gas type	Highest setting		Lowest setting
		kW	g/h	kW
Small burner	Natural gas H	1.0	–	0.25
	Liquid gas	1.0	73	0.25
Medium burner	Natural gas H	1.75	–	0.35
	Liquid gas	1.75	127	0.35
Wok	Natural gas H	3.8	–	1.10
	Liquid gas	3.8	277	1.10
Total	Natural gas H	8.3	–	
	Liquid gas	8.3	604	

Nominal ratings for KM 2032, KM 2033, KM 2050, KM 2051

Burner	Gas type	Highest setting		Lowest setting
		kW	g/h	kW
Small burner	Natural gas H	1.0	–	0.25
	Liquid gas	1.0	73	0.25
Medium burner	Natural gas H	1.75	–	0.35
	Liquid gas	1.75	127	0.35
Large burner	Natural gas H	2.6	–	0.5
	Liquid gas	2.6	189	0.6
Wok	Natural gas H	3.8	–	1.10
	Liquid gas	3.8	277	1.10
Total	Natural gas H	11.3	–	
	Liquid gas	11.3	822	

Installation

Electrical connection

The hob is supplied with a mains cable with moulded plug ready for connection to a suitable earthed socket.

The socket must be easily accessible after the hob has been installed. If the socket is not easily accessible, ensure that a suitable means of disconnection is provided on the installation side for each pole.



Risk of fire from overheating.
Connecting the hob to multi-socket adapters or extension cables can overload the cables.
For safety reasons, do not use an extension cable or multi-socket adapter.

The electrical installation must comply with BS 1363 requirements.

For safety reasons, we recommend using a type  residual current device (RCD) in the relevant electrical installation for connecting the hob.

If the mains connection cable is damaged, it must only be replaced with a specific mains connection cable of the same type (available by your miele dealer). For safety reasons, such replacement may only be carried out by a qualified specialist or by your miele dealer.

These operating instructions and the data plate indicate the nominal power consumption and the appropriate fuse rating. Compare this information with the data of the on-site electrical connection.

If in any doubt, consult a qualified electrician.

Temporary or permanent operation on an autonomous power supply system or a power supply system that is not synchronised with the mains power supply (e.g. island networks, back-up systems) is possible. A prerequisite for operation is that the power supply system complies with the specifications of EN 50160 or an equivalent standard. The function and operation of the protective measures provided in the domestic electrical installation and in this Miele product must also be maintained in isolated operation or in operation that is not synchronised with the mains power supply, or these measures must be replaced by equivalent measures in the installation. As described, for example, in the current version of BS OHSAS 18001-2 ISO 45001.

Converting to another gas type

 Risk of explosion due to an incorrect conversion.

If the conversion to another type of gas is carried out incorrectly, it may result in gas leakage.

Conversion from one type of gas to another must only be undertaken by an approved and registered gas installer in strict accordance with current local and national safety and building regulations. The installer is responsible for ensuring that the appliance functions correctly when installed.

Changing the jets

- Disconnect the hob from the electricity supply and turn off the gas supply.

When converting to another type of gas, both the main **and** small jets need to be changed.

Jet table

The jet markings refer to a $\frac{1}{100}$ mm bore diameter.

Burner	Ø	
	Main jet	Small jet
Natural gas H		
Small	0.69	0.39
Medium	0.95	0.42
Large	1.10	0.54
Wok	1.35	0.80
Liquid gas		
Small	0.50	0.27
Medium	0.65	0.32
Large	0.78	0.40
Wok	0.98	0.54

Converting to another gas type

Small, medium and large burners

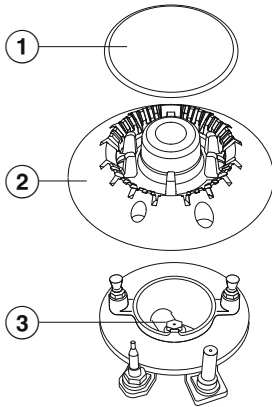

The burner cap ② is locked on these burners. You must turn it clockwise or anti-clockwise to remove it.

- Remove the pan support, burner cap ② and burner head ③.
- Using an M7 socket spanner, unscrew the main jet ⑧.
- Fit the correct jets securely (see jet table).
- Secure the jets against inadvertent loosening with sealing wax.

Converting to another gas type

Changing the small jets

To change the small jets, the burner fixing screws must first be loosened and the upper section of the appliance removed.

- Pull the control knobs off.
- Remove the burner components.
- Undo the screws.
- Lift the top of the appliance off.

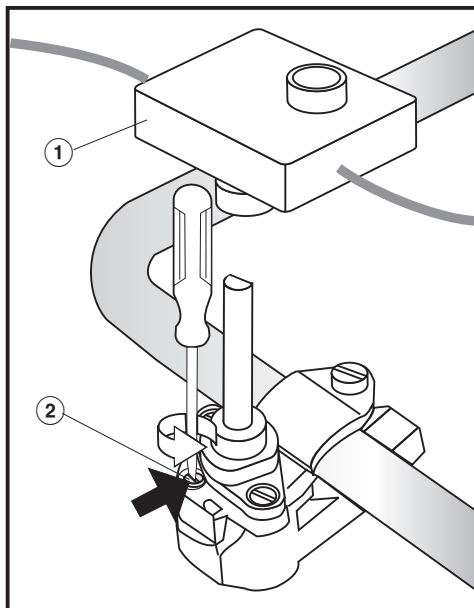

- Remove the ignition switch ①.
- Using a small screwdriver, unscrew the small jet ② in the gas fitting.
- Pull out the jet with a pair of pliers.
- Fit the correct jets securely (see jet table).
- Secure the jets against inadvertent loosening with sealing wax.

Converting to another gas type

Functional check

- Check all gas fittings for leaks.
- Reassemble the hob.
- Ignite all burners to check that they are operating correctly.
 - The flame must not go out on the lowest setting, or when the control is turned quickly from the highest to the lowest setting.
 - On the highest setting, the flame must have a distinctive and visible core.
- Adhere the label supplied with the jets, stating the type of gas being used.

Miele in Saudi Arabia:

Awad Badi Nahas Trading Co. Ltd.

Medina Road, P.O. Box 11529
Jeddah 21463
Kingdom of Saudi Arabia
Tel. +966 12 2560888
Hotline for customer care 920003240
(Sat – Thu; 8 am – 5 pm)
Fax +966 12 2560555
E-mail: info@awadnahas.com
Website: www.awadnahas.com

Miele in United Arab Emirates:

Miele Appliances Ltd.

Showroom 1 Eiffel 1 Building
Sheikh Zayed Road, Umm Al Sheif
P.O. Box 114782 - Dubai
United Arab Emirates
Tel. +971 4 3044 999
Fax +971 4 3418 852
800-MIELE (64353)
E-mail: info@miele.ae
Website: www.miele.ae
Webshop: shop.miele.ae

Miele in Kuwait:

Al Wazzan United Trading Co.

P. O. Box : 3379 Hawally 32034
Kuwait
Tel. 00965-22001010
Fax 00965-24838292
E-mail: mail@alwazzanunited.com
Website: www.alwazzanunited.com

Miele in Egypt:

B.Tech for Trade and Distribution

Ramses Extension, 6th Zone,
Nasr City - Cairo
Egypt
Tel. +202 23480700/15
Customer service contact: 15997
Fax +202 23426076
E-mail: info@btech.com
Website: www.mieleegypt.com

Manufacturer: Miele & Cie. KG, Carl-Miele-Straße 29, 33332 Gütersloh, Germany

