

Operating and installation instructions Induction hobs



To avoid the risk of accidents or damage to the appliance it is **essential** to read these instructions before it is installed and used for the first time.

Contents

Warning and Safety instructions	4
Caring for the environment	14
Guide to the appliance	15
Hob	15
Controls and display	16
Before using for the first time	17
Cleaning the hob for the first time	17
Switching on the hob for the first time	17
Miele@home	18
Con@ctivity	21
How it works	24
Pans	25
Tips on saving energy	27
Setting ranges	28
Operation	29
Using the appliance	29
Positioning cookware	30
Switching on the hob	32
Setting the power level	32
Switching the hob off	32
Residual heat indicator	32
Setting the power level – extended setting range	32
Auto heat-up	33
Booster function	34
Keeping warm	35
Timer	36
Minute minder	36
Auto switch off	37
Using both timer functions at the same time	38
Additional functions	39
Stop & Go	39
Recall	39
Wipe protection	40
Demo/showroom mode	40
Displaying hob data	41

Safety features	42
System lock/safety lock	42
Safety switch-off	43
Overheating protection.....	44
Programming	45
Cleaning and care	49
Problem solving guide	51
Messages in the display.....	51
Unexpected behaviour	53
Unsatisfactory results.....	54
General problems or technical faults.....	55
Optional accessories	56
After sales service	57
Contact in case of malfunction	57
Data plate	57
Guarantee.....	57
Installation	58
Safety instructions for installation	58
Safety distances.....	59
Installation notes – surface-mounted.....	63
Installation dimensions – Surface-mounted	64
KM 7678-2 FL, KM 7878-2 FL Diamond	64
KM 7897-2 FL Diamond.....	65
Surface-mounted installation	66
Installation notes – flush-fit	67
Installation dimensions – Flush-fit	68
KM 7678-2 FL, KM 7878-2 FL Diamond	68
KM 7897-2 FL Diamond.....	69
Flush-fit installation	70
Electrical connection	71

Warning and Safety instructions

This hob complies with all relevant local and national safety requirements. Inappropriate use can, however, lead to personal injury and material damage.

Read the operating and installation instructions carefully before using the hob. They contain important information on safety, installation, use and maintenance. This prevents both personal injury and damage to the hob.

Miele expressly and strongly advises that you read and follow the instructions in the chapter on installing the hob as well as the safety instructions and warnings.

Miele cannot be held liable for injury or damage caused by non-compliance with these instructions.

Keep these instructions in a safe place and pass them on to any future owner.

Correct application

- ▶ This hob is intended for domestic use and use in other similar environments.
- ▶ This hob is not intended for outdoor use.
- ▶ It is intended for domestic use only to cook food and keep it warm. Any other use is not supported by the manufacturer and could be dangerous.
- ▶ This hob is not intended for use by people with reduced physical, sensory or mental capabilities or lack of experience and knowledge, unless they have been given supervision and instruction concerning its use by a person responsible for their safety. They may only use the hob unsupervised if they have been shown how to use it in a safe way. They must be able to recognise and understand the dangers of misuse.

Warning and Safety instructions

Safety with children

- ▶ Children under 8 years of age must be kept away from the hob unless they are constantly supervised.
- ▶ Children over 8 years of age may use the hob without supervision if its operation has been clearly explained to them and they are able to use it safely. Children must be able to understand and recognise the possible dangers caused by incorrect operation.
- ▶ Children must not be allowed to clean the hob unsupervised.
- ▶ Please supervise children in the vicinity of the hob and do not let them play with it.
- ▶ The hob gets hot when in use and remains hot for a while after being switched off. Keep children well away from the hob until it has cooled down and there is no danger of burning.
- ▶ Danger of burning. Do not store anything which might arouse a child's interest in storage areas above or behind the hob. Otherwise they could be tempted to climb onto the hob.
- ▶ Risk of burning and scalding. Place pots and pans on the cooking zone in such a way that children cannot pull them down and burn themselves.
- ▶ Danger of suffocation. Packaging, e.g. plastic wrappings, must be kept out of the reach of babies and children. Whilst playing, children could become entangled in packaging or pull it over their head and suffocate.
- ▶ Activate the system lock to ensure that children cannot switch on the hob inadvertently. Use the safety lock when the hob is in use to prevent children from altering the settings selected.

Technical safety

- ▶ Unauthorised installation, maintenance and repairs can cause considerable danger for the user. Installation, maintenance and repairs must only be carried out by your Miele dealer.
- ▶ Damage to the hob can compromise your safety. Check the hob for visible signs of damage. Do not use the hob if it is damaged.
- ▶ Temporary or permanent operation on an autonomous power supply system or a power supply system that is not synchronised with the mains power supply (e.g. island networks, back-up systems) is possible. A prerequisite for operation is that the power supply system complies with the specifications of EN 50160 or an equivalent standard.

The function and operation of the protective measures provided in the domestic electrical installation and in this Miele product must also be maintained in isolated operation or in operation that is not synchronised with the mains power supply, or these measures must be replaced by equivalent measures in the installation. As described, for example, in the current version of BS OHSAS 18001–2 ISO 45001.

- ▶ The electrical safety of this hob can only be guaranteed when correctly earthed. It is essential that this standard safety requirement is met. If in any doubt please have the electrical installation tested by a qualified electrician.
- ▶ To avoid the risk of damage to the hob, make sure that the connection data on the data plate (voltage and frequency) match the mains electricity supply before connecting it to the mains. Consult a qualified electrician if in doubt.
- ▶ Do not connect the hob to the mains electrical supply by a multi-socket adapter or extension lead. These are a fire hazard and do not guarantee the required safety of the appliance.
- ▶ For safety reasons, this hob may only be used after it has been built in.

Warning and Safety instructions

- ▶ This hob must not be used in a non-stationary location (e.g. on a ship).
- ▶ Never open the casing of the hob.
Touching or tampering with electrical connections or components and mechanical parts is highly dangerous to the user and can cause operational faults.
- ▶ While the hob is under warranty, repairs should only be undertaken by your Miele dealer. Otherwise the warranty is invalidated.
- ▶ Miele can only guarantee the safety of the appliance when genuine original Miele replacement parts are used. Faulty components must only be replaced by Miele spare parts.
- ▶ The hob is not intended for use with an external timer switch or a remote control system.
- ▶ The hob must be connected to the electricity supply by a qualified electrician (see “Installation – Electrical connection”).
- ▶ If the mains connection cable is damaged, it must be replaced with a special mains connection cable by a qualified electrician (see “Electrical connection” in the “Installation” chapter).
- ▶ The hob must be disconnected from the mains electricity supply during installation, maintenance and repair work. Ensure that power is not supplied to the appliance until after it has been installed or until any maintenance or repair work has been carried out.
- ▶ Danger of electric shock. Do not use the hob if it is faulty, or if the ceramic surface is cracked, chipped or damaged in any way. Switch it off immediately, disconnect it from the mains electricity supply and contact your Miele dealer.

Warning and Safety instructions

- ▶ If the hob is installed behind a cabinet door, do not close the door while the hob is in use. Heat and moisture can build up behind the closed door. This can result in damage to the hob, the housing unit and the floor. Do not close the door until the residual heat indicators go out.
- ▶ In areas which may be subject to infestation by cockroaches or other vermin, pay particular attention to keeping the appliance and its surroundings clean at all times. Any damage caused by cockroaches or other vermin will not be covered by the warranty.

Warning and Safety instructions

Correct use

- ▶ The hob gets hot when in use and remains hot for a while after being switched off. There is a danger of burning until the residual heat indicators go out.
- ▶ Oil and fat can overheat and catch fire. Do not leave the hob unattended when cooking with oil and fat. If it does ignite do not attempt to put the flames out with water. Disconnect the hob from the mains and use a suitable fire blanket, saucepan lid, damp towel or similar to smother the flames.
- ▶ Do not leave the hob unattended whilst it is being used. It should be continually monitored whilst boiling and flash frying.
- ▶ Flames could set the grease filters of a cooker hood on fire. Do not flambé under a cooker hood.
- ▶ Spray canisters, aerosols and other inflammable substances can ignite when heated. Therefore do not store such items or substances in a drawer under the hob. Cutlery inserts must be heat-resistant.
- ▶ Do not heat an empty pan.
- ▶ Do not heat up food in closed containers e.g. tins or sealed jars on the hob, as pressure can build up in the container, causing it to explode.
- ▶ Do not cover the hob, e.g. with a hob cover, a cloth or protective foil. The material could catch fire, shatter or melt if the hob is switched on by mistake or if residual heat is still present.
- ▶ When the appliance is switched on either deliberately or by mistake, or when there is residual heat present, there is the risk of metal items placed on the hob heating up. Other materials can melt or catch fire. Damp pan lids might adhere to the ceramic surface and be difficult to dislodge. Do not use the hob as a resting place for anything. Switch the hob off after use.

Warning and Safety instructions

- ▶ You could burn yourself on the hot hob. Protect your hands with heat-resistant pot holders or gloves when handling hot pots and pans. Do not let them get wet or damp, as this causes heat to transfer through the material more quickly with the risk of scalding or burning yourself.
- ▶ When using an electrical appliance, e.g. a hand-held food blender, near the hob, ensure that the cable of the electrical appliance cannot come into contact with the hot hob. The insulation on the cable could become damaged.
- ▶ Grains of salt, sugar and sand (e.g. from cleaning vegetables) can cause scratches if they get under pan bases. Make sure that the ceramic surface is clean before placing pans on it.
- ▶ Even a light object can cause damage in certain circumstances. Do not drop anything on the ceramic surface.
- ▶ Placing hot pans on the sensors and indicators could damage the electronics underneath. Do not place hot pans on the sensors or indicators.
- ▶ Do not allow solid or liquid sugar, or pieces of plastic or aluminium foil to get onto the hob when it is hot, as they can damage the ceramic surface when it cools down. If this should occur, switch off the appliance and scrape off all the sugar, plastic or aluminium residues whilst still hot, using a shielded scraper blade suitable for use on glass. Wear oven gloves when doing this. Allow the ceramic surface to cool down and then clean it with a suitable ceramic hob cleaning agent.
- ▶ Pans which boil dry can cause damage to the ceramic glass. Do not leave the hob unattended whilst it is being used.
- ▶ Only use pots and pans with smooth bases. Rough bases will scratch the ceramic glass.
- ▶ Lift pans into position on the hob. Sliding them into place can cause scuffs and scratches.

Warning and Safety instructions

- ▶ Because induction heating works so quickly, the base of the pan could, under certain circumstances, heat up to the temperature at which oil or fat self-ignites within a very short time. Never leave the hob unattended during use!
- ▶ Heat oil or fat for a maximum of one minute. Never use the Booster function to heat oil or fat.
- ▶ For people fitted with a heart pacemaker: Please note that the area immediately surrounding the hob is electromagnetically charged. It is very unlikely to affect a pacemaker. However, if in any doubt, consult the manufacturer of the pacemaker or your doctor.
- ▶ To prevent damage to items which are susceptible to electromagnetic fields, e.g. credit cards, digital storage devices, pocket calculators, etc, do not leave them in the immediate vicinity of the hob.
- ▶ Metal utensils stored in a drawer under the hob can become hot if the appliance is used intensively for a long time.
- ▶ The hob is fitted with a cooling fan. If a drawer is fitted directly underneath the hob, ensure that there is sufficient space between the drawer and its contents and the underside of the hob in order to ensure sufficient ventilation for the hob.
- ▶ If a drawer is fitted directly underneath the hob, do not store any pointed or small items, paper, serviettes, etc. in the drawer. They could get in through the ventilation slots or be sucked into the casing by the fan and damage the fan or impair cooling.
- ▶ The induction generators could be damaged or even destroyed if you use an induction adapter plate for cookware. Do not use induction adapter plates.

Cleaning and care

- ▶ Do not use a steam cleaning appliance to clean this hob. The steam could reach electrical components and cause a short circuit.
- ▶ If the hob is built in over a pyrolytic oven, the hob should not be used whilst the pyrolytic process is being carried out, as this could trigger the overheating protection mechanism on the hob (see relevant section).
- ▶ Miele will guarantee to supply functional spare parts for a minimum of 10 years and up to 15 years following the discontinuation of your hob.

Caring for the environment

Disposing of the packaging material

The packaging material is used for handling and protects the appliance from transport damage. The packaging material used is selected from materials which are environmentally friendly for disposal and can generally be recycled.

Recycling the packaging material reduces the use of raw materials. Use material-specific collection points for valuable materials and take advantage of return options. Your Miele dealer will take the packaging material away.

Disposal of your old appliance

Electrical and electronic appliances often contain valuable materials. They also contain materials which, if handled or disposed of incorrectly, could be potentially hazardous to human health and to the environment. They are, however, essential for the correct functioning of your appliance. Please do not therefore dispose of it with your household waste.

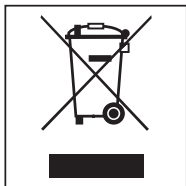

Please dispose of it at your local community waste collection / recycling centre or contact your Miele dealer for advice.

Ensure that it presents no danger to children while being stored for disposal.

Hob

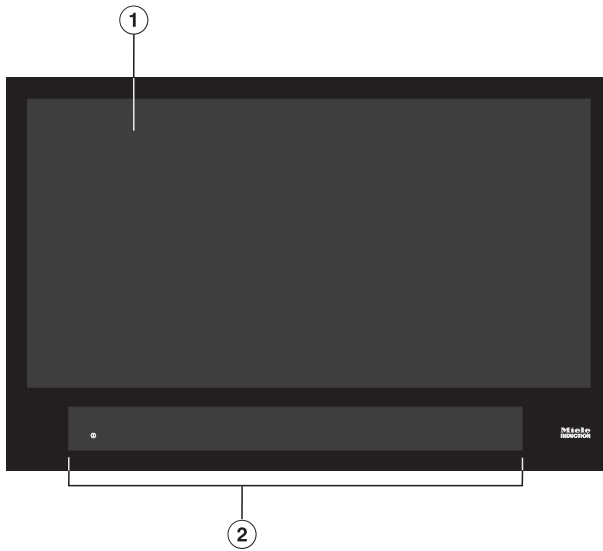

- ① Useable surface of the hob for a maximum of 6 pans
- ② Controls and indicators

Guide to the appliance

Controls and display

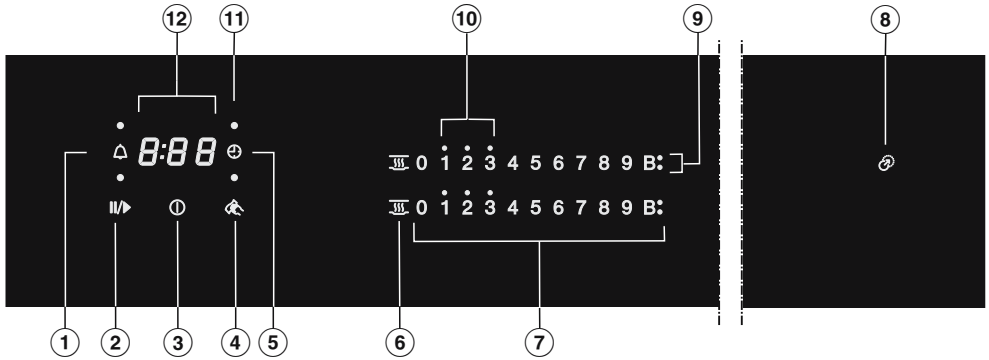

- ① Minute minder sensor control
- ② Stop&Go sensor control
To stop/start a cooking process in progress
- ③ Hob On/Off sensor control
- ④ Wipe protection sensor control
To lock the sensor controls
- ⑤ Auto switch off sensor control
Switches off the heating for an item of cookware
- ⑥ Keeping warm sensor control
To activate/deactivate the Keeping warm function
- ⑦ Numerical display sensor controls
 - To set the power level
 - To set the times
- ⑧ Positioning aid indicator light
- ⑨ Booster display
Booster function is activated
- ⑩ Residual heat indicator lights
- ⑪ Cookware allocation auto switch off indicator light
Auto switch off for the heating for an item of cookware is activated
- ⑫ Timer display

0:00 to 9:59 Time

LOC System lock/safety lock is activated

dE Demo mode is activated

Before using for the first time

- Please stick the extra data plate for the appliance supplied with this documentation in the space provided in the “After sales service” section of this booklet.
- Remove any protective wrapping and stickers.

Cleaning the hob for the first time

- Before using for the first time, clean the hob with a damp cloth only and then wipe dry.

Switching on the hob for the first time

The metal components have a protective coating which may give off a slight smell when heated up for the first time. The induction coils may also give off a slight smell for the first few hours of operation. This smell will be less noticeable with each subsequent use before dissipating completely.

The smell and any vapours given off do not indicate a faulty connection or appliance and they are not hazardous to health.

Please note that the heating up time on induction hobs is very much shorter than on conventional hobs.

Before using for the first time

Miele@home

Prerequisite: home WiFi network

Your hob is equipped with an integrated WiFi module. The hob can be connected to your home WiFi network.

If your Miele cooker hood is also connected to the home WiFi network, you can control the cooker hood automatically with the Con@ctivity function. Further information can be found in the operating and installation instructions for your cooker hood.

Make sure that the signal of your WiFi network is sufficiently strong in the place where your hob is installed.

There are a number of ways of connecting your hob to your WiFi network.

The hob requires max. 2 W in networked standby.

Availability of the WiFi connection

The WiFi connection shares a frequency range with other appliances (including microwave ovens and remote control toys). This can give rise to sporadic or even complete connection failures. Therefore, the availability of featured functions cannot be guaranteed.

Miele@home availability

The ability to use the Miele app depends on the availability of the Miele@home service in your country.

The Miele@home service is not available in every country.

For information about availability, please visit www.miele.com.

Miele App

The Miele App is available to download free of charge from the Apple App Store® or from the Google Play Store™.



After installing the Miele app on a mobile device, you can do the following:

- Call up information on the operating status of your hob
- Call up information on the programme sequence of your hob
- Set up a Miele@home network with other WiFi-enabled Miele appliances

Before using for the first time

Setting up Miele@home

Connecting via the app

The Miele app can be used to connect to your network.

- Install the Miele app on your mobile device.

To connect, you will need:

1. Your WiFi network password
2. The password for your hob

The password for your hob consists of the last 9 digits of the serial number. This can be found on the appliance's data plate.

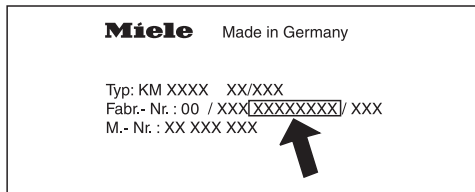

- Switch the hob on.
- Place an induction-compatible item of cookware on the hob.
- Start the Miele app.
- Touch and hold the 0 and 5 sensor controls on the numerical display at the same time for 6 seconds.

The seconds can be seen counting down in the timer display. After this time has elapsed, the code C:07 is displayed in the timer display for 10 seconds.

You now have 10 minutes to configure the WiFi.

- Follow the user navigation in the app.

Connecting via WPS

Prerequisite: you must have a WPS (WiFi protected setup) compatible router.

- Switch the hob on.
- Place an induction-compatible item of cookware on the hob.
- Touch and hold the 0 and 6 sensor controls on the numerical display at the same time for 6 seconds.

The seconds can be seen counting down in the timer display. After the time has elapsed, a progress light appears in the timer display during the connection attempt (for max. 120 seconds).

The WPS login is only active during these 120 seconds.

- Activate the WPS function on your WiFi router.

If the connection was successful, the code C:02 appears in the timer display. If the connection could not be established, the timer display will show the code C:07 . You have probably not activated WPS on your router quickly enough. Repeat the steps above.

Tip: If your WiFi router does not support WPS, please connect via the Miele app.

Before using for the first time

Canceling the process

- Touch any sensor control.

Resetting settings

Resetting is not required when replacing the router.

- Switch the hob on.
- Place an induction-compatible item of cookware on the hob.
- Touch and hold the 0 and 9 sensor controls on the numerical display at the same time for 6 seconds.

The seconds can be seen counting down in the timer display. After this time has elapsed, the code `C:00` is displayed in the timer display for 10 seconds.

Reset the settings if you are disposing of your hob, selling it or putting a used hob into operation. This is the only way to ensure that all personal data has been removed and the previous owner will no longer be able to access the hob.

Con@ctivity

Con@ctivity is the direct communication system between your hob and a Miele cooker hood. Con@ctivity enables the cooker hood to operate automatically depending on the operating status of a hob.

Further information can be found in the operating and installation instructions for your cooker hood.

The hob requires max. 2 W in networked standby.

Availability of the WiFi connection

The WiFi connection shares a frequency range with other appliances (including microwave ovens and remote control toys). This can give rise to sporadic or even complete connection failures. Therefore, the availability of featured functions cannot be guaranteed.

Setting up Con@ctivity

You can set up Con@ctivity between the hob and cooker hood using your home WiFi network or a direct WiFi connection.

Con@ctivity via the home WiFi network (Con@ctivity 3.0)

Requirements:

- Home WiFi network
- WiFi-enabled Miele cooker hood

- Connect the cooker hood and the hob to your home WiFi network (see “Before using for the first time – Miele@home”).

The Con@ctivity function will be activated automatically.

You can find the necessary information on connecting the cooker hood in the associated operating and installation instructions.

Before using for the first time

Con@ctivity via a direct WiFi connection (Con@ctivity 3.0)

Prerequisite: WiFi-enabled Miele cooker hood

You can find the necessary information on connecting the cooker hood in the associated operating and installation instructions.

With a direct WiFi connection, it is not possible to connect the hob and the cooker hood to a home network. If this is desired later, the direct WiFi connection between the hob and the cooker hood must first be reset (see “Initial commissioning – Con@ctivity” and “Disconnecting the WiFi” in the operating and installation instructions for the cooker hood).

- Switch the hob on.
- Place an induction-compatible item of cookware on the hob.
- Touch and hold the 0 and 7 sensor controls on the numerical display at the same time for 6 seconds.

The seconds can be seen counting down in the timer display. After the time has elapsed, a progress light appears in the timer display during the connection attempt. If the connection was successful, the code C:D2 appears in the timer display. If the connection could not be established, the timer display will show the code C:D1 . Repeat the steps above.

When successfully connected, displays **2** and **3** will light up constantly on the cooker hood.

- Quit connection mode on the cooker hood by pressing the run-on $\text{5} \text{↵}^{15}$ button.

Con@ctivity is now activated.

labelling="Section-Header">Cancelling the process

- Touch any sensor control.

labelling="Section-Header">Resetting settings

Resetting is not required when replacing the router.

- Switch the hob on.
- Place an induction-compatible item of cookware on the hob.
- Touch and hold the 0 and 9 sensor controls on the numerical display at the same time for 6 seconds.

The seconds can be seen counting down in the timer display. After this time has elapsed, the code `C:00` is displayed in the timer display for 10 seconds.

Reset the settings if you are disposing of your hob, selling it or putting a used hob into operation. This is the only way to ensure that all personal data has been removed and the previous owner will no longer be able to access the hob.

How it works

Induction coils are located under the ceramic surface. These coils create a magnetic field that reacts directly with the base of the cookware and heats it up. The ceramic surface itself is heated up indirectly by the heat given off by the cookware.

The position, size and shape of the cookware are recognised automatically by the induction hob.

An induction cooking zone only works when cookware with a magnetic base is placed on it (see “Cookware”).



Risk of burning due to hot items.

When the appliance is switched on either deliberately or by mistake, or when there is residual heat present, there is the risk of metal items placed on the hob heating up.

Do not use the appliance as a resting place for anything.

After use, switch the hob off with the  sensor control.

Noises

The following noises can occur in the cookware, depending on what it is made of and how it has been constructed:

Buzzing on the higher power levels. This will decrease or cease altogether when the power level is reduced.

If the cookware is made of layers of different materials (e.g. in a sandwiched base), it might emit a crackling sound.

You might hear a clicking sound from the electronic switches, especially at lower power levels.

A whirring sound, when the cooling fan comes on. This switches on to protect the electronics when the hob is being used intensively. The fan may continue to run after the appliance has been switched off.

Suitable cookware

- Stainless steel cookware with a magnetic base
- Enamelled steel cookware
- Cast iron

Please be aware that the properties of the cookware base can affect the evenness with which the food heats up (e.g. when making pancakes). The base of the pan must be able to distribute the heat evenly. Cookware with a base made from multilayer material (sandwich or encapsulated base) is ideal in this case.

The pan base material and the positions of the pans on the hob affect the power of the induction coils. This can affect the cooking behaviour.

Cookware size

Round cookware should preferably have a base diameter from 145 mm up to a maximum of 350 mm. Cookware with a base diameter between 100 mm and 145 mm will not be detected in every position on the hob.

Oval/square cookware must not exceed dimensions of 380 mm x 300 mm.

Unsuitable pans.

- stainless steel pans without a magnetic base
- aluminium or copper pans
- glass, ceramic or earthenware pots and pans

Testing pans

To test whether a pan is induction-compatible, hold a magnet to the base of the pan. If the magnet sticks, the pan is generally suitable.

Unsuitable pan indicator

When the hob is switched on and you place a pan on a cooking zone but the corresponding number display does not appear:

- the diameter of the base of the pan is too small or
- the pan is unsuitable

Pans

Tips

- Use only cookware with smooth bases. Rough bases can scratch the ceramic glass.
- Always lift cookware to move it. This will help prevent scratching. If any scratches do appear as a result of cookware being pushed around, this will not affect the function of the hob. These scratches are normal signs of use and are not grounds for making a complaint.
- Please note that the cookware diameter quoted by manufacturers often refers to the maximum diameter or diameter of the top rim. The diameter of the base (generally smaller) is more important.



- Where possible, use cookware with vertically straight sides. If an item of cookware has angular sides, induction also acts on the sides of the item of cookware. The sides of the item of cookware may discolour or the coating may peel off.

Tips on saving energy

- Cook in covered pots and pans if possible. This prevents heat escaping unnecessarily.
- Cook with as little water as possible.
- When you have brought the pan to the boil, switch to a lower power level as soon as possible.
- Use a pressure cooker to reduce cooking durations.

Setting ranges

The hob is programmed with 9 power levels at the factory. If you wish to fine-tune a setting, you can extend the power level range to 17 power levels (see “Programming”).

	Setting range	
	Factory setting (9 power levels)	Extended setting (17 power levels)
Melting butter Melting chocolate Dissolving gelatine	1–2	1–2.
Warming up small quantities of liquid Keeping warm food which sticks easily Cooking rice or porridge Defrosting vegetables frozen in a block	2–4	2–3.
Warming up liquid and semi-solid food Steaming fruit Simmering potatoes (cookware with lids)	4–6	3.–5.
Making omelettes or lightly fried eggs Gently frying meat patties Steaming fish and vegetables Cooking dumplings and dried pulses Defrosting and reheating frozen food Thickening sauces, e.g. Hollandaise	5–7	4.–7.
Gently frying fish, escalopes, sausages, fried eggs (without overheating the fat)	6–8	6–7.
Cooking potato fritters, pancakes, etc.	7–8	7–8.
Frying, e.g. chips	9	8.–9
Boiling large quantities of water Bringing to the boil Searing large quantities of meat	9–Booster	8.–Booster

These settings should only be taken as a guide. The power of the induction coils will vary depending on the cookware base size and material and the positions of the cookware on the hob. For this reason, it is possible that the power levels will need to be adjusted slightly to suit your cookware. As you use the hob, you will get to know which settings suit your cookware best. When using new cookware that you are not familiar with, set the power to one level below the one specified.

Using the appliance

This ceramic hob is equipped with electronic sensor controls which react to finger contact. For safety reasons, in order to switch the appliance on, the On/Off ① sensor needs to be touched for a little longer than the other sensors. Each time a sensor control is activated, an audible signal sounds.

Only the printed On/Off ① symbol is visible when the hob is switched off. More sensors light up when the hob is switched on.

 Malfunction due to dirty and/or covered sensor controls.

If the sensor controls are dirty or covered, this could cause them to fail to react, to activate a function or even to switch the appliance off automatically (see “Safety features – Safety switch-off”). Placing hot cookware on the sensor controls/ indicators can damage the electronic unit underneath.

Keep the sensor controls and indicators clean.

Do not place anything over the sensor controls or indicators.

Do not place hot cookware over the sensor controls or indicators.



① Sensor controls and indicators

Operation

Positioning cookware

You can use a maximum of 6 pans at the same time on this hob.

Tips

- You can position the pans anywhere on the useable surface of the hob.
- We recommend switching the hob on first and then placing the pans on it. If you do this, the pans will be detected more quickly by the hob.
- If you are using several pans at once, position them as far apart as possible. This will enable the hob to recognise each of them individually.
- Move pans on the hob one after the other, not all at the same time.
- When you move a pan on the hob, the associated numerical keybank lights up. The set power level “goes along” with it.
- Pans with a base diameter between 100 and 145 mm will not be detected in every position on the hob.

Possible faults

You place a pan on the hob and the associated numerical keybank does not appear.

The pan cannot be detected in this position because it is very small.

- Re-position the pan. If it is still not detected, use a different pan.

There are several pans on the hob. You place another pan on the hob and the  symbol lights up.

The pans are too close together.

- Re-position the pans.

Move pans on the hob one after the other, not all at the same time.

You re-position a pan and the set power level starts to flash.

The pan cannot be detected.

- Touch the flashing power level.
- If the power level continues to flash, re-position the pan.

You re-position a pan, the set power level goes out and **0** lights up.

- Reset the power level.

Operation

 Risk of fire with overheated food. Unattended food can overheat and catch alight. Do not leave the hob unattended whilst it is being used.

Please note that the heating up time on induction hobs is very much shorter than on conventional hobs.

Switching on the hob

- Touch the ① sensor.

Other sensors will light up.

If no further entry is made, the hob will switch itself off after a few seconds for safety reasons.

Setting the power level

- Place the pans in the required position on the hob.

The corresponding numerical keybank lights up.

- Touch the appropriate sensor control on the numerical keybank for the power level you want.

If you do not set a power level within approx. 10 seconds, the numerical keybank will go out.

Switching the hob off

- Touch the ① sensor control.

Residual heat indicator

If the an area of the ceramic surface is hot, the residual heat indicator will light up after the hob has been switched off. Depending on the temperature, a dot will appear above power levels 1, 2 and 3.

The dots of the residual heat indicator go out one after the other as the ceramic surface cools down. The last dot only goes out when the ceramic surface is safe to touch.

 Risk of burning due to hot ceramic surface. The ceramic surface will be hot after use. Do not touch the ceramic surface while the residual heat indicators are on.

Setting the power level – extended setting range

- Touch the numerical display in between two number sensors.

The numbers to the left and right of the interim level light up brighter than the other sensor controls.

Example:
if you have set power level 7. the numbers 7 and 8 will be brighter than the other numbers.

Auto heat-up

When Auto heat-up has been activated, the cooking zone switches on automatically at the highest setting and then switches to the continued cooking setting which you have previously selected. The heat-up time depends on which continued cooking setting has been chosen (see chart).

Activating Auto heat-up

- Touch the sensor for the continued cooking setting you want until a tone sounds and the sensor starts to pulsate.

During the heat-up time (see chart), the continued cooking level set will pulsate. With extended power levels (see “Programming”), the sensors for the power levels in front of and after the interim power level will pulsate if an extended power level setting has been selected.

Altering the continued cooking setting will deactivate Auto heat-up.

Deactivating Auto heat-up

- Touch the sensor for the continued cooking setting.
- or
- Set another power level.

Continued cooking setting*	Heat-up time [min:sec]
1	Approx. 0:15
1.	Approx. 0:15
2	Approx. 0:15
2.	Approx. 0:15
3	Approx. 0:25
3.	Approx. 0:25
4	Approx. 0:50
4.	Approx. 0:50
5	Approx. 2:00
5.	Approx. 5:50
6	Approx. 5:50
6.	Approx. 2:50
7	Approx. 2:50
7.	Approx. 2:50
8	Approx. 2:50
8.	Approx. 2:50
9	–

* The continued cooking settings with a dot after the number are only available if the power level range has been extended (see “Programming”).

Operation

Booster function

When the Booster function is activated, the power is boosted so that large quantities can be heated up quickly, e.g. when boiling water for cooking pasta. The boost in power is active for a maximum of 15 minutes.

You can use the Booster function for a maximum of 3 items of cookware at the same time: 1 on the right-hand side of the hob, 1 in the centre and 1 on the left-hand side.

If the Booster function is switched on when

- no power level has been selected, the cooking zone will revert automatically to level 9 at the end of the Booster time or if the Booster function is switched off before this.
- a power level has been selected, the cooking zone will revert automatically to the power level selected at the end of the Booster time or if the Booster function is switched off before this.

While the Booster is in operation, some of the power is taken away from the other induction coils. If an induction coil gives power to another coil, this can have the following effects:

- Auto heat-up is deactivated.
- The power level is reduced.
- The heating is switched off.

Activating TwinBooster

Level 1

- Place the pans in the required position on the hob.
- Select a power level if necessary.
- Touch the **B** sensor control.

The indicator ● for TwinBooster level 1 lights up.

Level 2

- Place the pans in the required position on the hob.
- Select a power level if necessary.
- Touch the **B** sensor control twice.

The indicator ●● for TwinBooster level 2 lights up.

Deactivating TwinBooster

- Touch the **B** sensor control repeatedly until the indicator lights go out.

or

- Set another power level.

Keeping warm

This function is for keeping food warm which has just been cooked and is still hot. It is not for reheating food that has gone cold.

The maximum duration for keeping food warm is 2 hours.

- Only use pans for keeping food warm. Cover the pan with a lid.
- Stir firm or viscous food (mashed potatoes, stew) occasionally.
- Nutrients are lost when food is cooked, and continue to diminish when food is kept warm. The longer food is kept warm, the greater the loss of nutrients. Try to ensure that food is kept warm for as short a time as possible.

Activating/deactivating the keeping warm function

- Touch the  sensor control on the corresponding numerical keybank.

Keeping-warm temperatures

A keeping-warm temperature of 75 °C is set as standard. You can change the keeping-warm temperature (see “Programming”).

Use	Temperature °C
Melting chocolate	50–55
Keeping solid food and thick liquids warm	65–75
Keeping clear soups warm	80–90

The cooking result can be negatively affected if food is kept warm at excessively high temperatures. Food can change colour and even spoil.

Timer

The hob has to be switched on if you want to use the timer.

The timer can be used for the following 2 functions:

- For setting the minute minder
- For automatically switching off the heat for an item of cookware

You can use the functions simultaneously.

A duration of between 1 minute (0:01) and 9 hours 59 minutes (9:59) can be set.

Durations of up to 59 minutes are shown in minutes (00:59) and durations of more than 60 minutes are shown in hours and minutes. Durations are entered in the order of hours, followed by minutes in tens and then units.

Example:

59 minutes = 00:59 hours,

Enter: 5-9

80 minutes = 1:20 hours,

Enter: 1-2-0

After the first number has been entered, the timer display will light up constantly.

After the second number has been entered, the first number will move to the left. After the third number has been entered, the first and second numbers will move to the left.

Minute minder

The minute minder is set using the numerical display for the left or front left cooking zone (depending on model).

Setting the minute minder

- Touch the  sensor control.

The timer display flashes.

- Set the required duration.

Touch the  sensor control or wait 10 seconds to start the minute minder.

Changing the minute minder duration

- Touch the  sensor control.

The timer display flashes.

- Set the required duration.

Deleting the minute minder duration

- Touch the  sensor control.

- Touch  on the numerical display.

Auto switch off

You can set a time after which the heat for an item of cookware will switch off automatically. This function can be used for all cookware at the same time.

If the time programmed is longer than the maximum operating time allowed, the heating of the cookware will be switched off by the safety switch-off function (see "Safety features – Safety switch-off").

The switch-off time is set on the numerical display for each item of cookware you want to switch off automatically.

If you re-position an item of cookware and reset the power level, the switch-off time will be deleted. You must then reset the switch-off time.

Setting the switch-off time

- Set a power level for the required item of cookware.
- Touch the ⌚ sensor control.

The timer display flashes.

- Set the required duration.

Touch the ⌚ sensor control or wait 10 seconds to start the switch-off time.

The cookware allocation auto switch off indicator light pulsates.

- To set a switch-off time for another item of cookware, follow the same steps as described above.

If more than one switch-off time is programmed, the shortest time left will be displayed, and the corresponding indicator light will pulsate. The other indicator lights will light up constantly.

- If you want to show the time left for another item of cookware which is counting down in the background, touch the ⌚ sensor control until the indicator light for the desired item of cookware pulsates.

Changing the switch-off time

- Touch the ⌚ sensor control repeatedly until the indicator light for the item of cookware you require pulsates.

The timer display flashes.

- Set the required duration.

Deleting the switch-off time

- Touch the ⌚ sensor control repeatedly until the indicator light for the item of cookware you require pulsates.



The timer display flashes.

- Touch the ⌚ sensor control on the numerical display.

Timer

Using both timer functions at the same time

If you use both functions simultaneously, the shortest time is always displayed. The  sensor control (minute minder) or the indicator light for the item of cookware with the shortest time pulsates.

- If you want to show the times left counting down in the background, touch the  or  sensor control.
- If one switch-off time has been programmed for several items of cookware, touch the  sensor control repeatedly until the indicator light for the required item of cookware pulsates.

Stop & Go

When Stop & Go is activated, all power levels are reduced to 1.

The power levels and the timer settings cannot be altered; the hob can only be switched off. The minute minder, switch-off, Booster and AutoBoost times continue to run.

When the function is deactivated, the appliance switches back to the power level that was set last.

If the function is not deactivated within 1 hour, the hob will switch off.

Activating/Deactivating

- Touch the II/▶ sensor control.

Use this function if there is a danger of food boiling over.

Recall

If the hob is switched off by mistake during use, this function can be used to reset all settings. For this to work, the hob must be switched on again within 10 seconds of being switched off.

- Switch the hob on again.

The previously set power levels flash.

- Press one of the flashing power level indicators immediately.

All settings are restored.

Additional functions

Wipe protection

The hob sensors can be locked for 20 s in order, for example, to remove soiling. The ① is not locked.

Activating

- Touch the  sensor.

The time will count down in the timer display.

Deactivating

- Touch the  sensor until the timer display goes out.

Demo/showroom mode

These functions enable the hob to be demonstrated in dealer showrooms without heating up.

Activating/deactivating demo mode

When this mode is set, the hob can be operated as normal.

- Switch the hob on.
- Place an induction-compatible item of cookware on the hob.
- Touch and hold the 0 and 2 sensor controls on the numerical display at the same time for 6 seconds.

In the timer display, *dE* flashes alternately with *On* (demo mode activated) or *OFF* (demo mode deactivated) for a few seconds.

Activating/deactivating showroom mode

In showroom mode, cooking processes are simulated in an infinite loop. The sequence of the individual steps is repeated after 1 minute. When you touch a sensor control or place cookware on the hob, it switches to demo mode.

- Switch the hob on.
- Place an induction-compatible item of cookware on the hob.
- Touch and hold the 0 and 8 sensor controls on the numerical display at the same time for 6 seconds.

In the timer display, *dE* flashes alternately with *On* (showroom mode activated) or *OFF* (showroom mode deactivated) for a few seconds.

Displaying hob data

The model identifier and software version of the hob can be displayed.

Model identifier/serial number

- Switch the hob on.
- Place an induction-compatible item of cookware on the hob.
- Touch and hold the 0 and 4 sensor controls on the numerical display at the same time.

Numbers will appear in the timer display one after another, separated by a dash.

Example: *12 34* (model identifier KM 1234) – *1 23 45 67 89* (serial number)

Software version

- Switch the hob on.
- Place an induction-compatible item of cookware on the hob.
- Touch and hold the 0 and 3 sensor controls on the numerical display at the same time.

Numbers appear in the timer display:

Example: *2:00* = software version 2.00

Safety features

System lock/safety lock

Your hob is equipped with a system lock and a safety lock to prevent it being switched on or any settings being altered by mistake.

The **system lock** is activated when the hob is switched off. If the system lock is activated, the hob cannot be switched on and the timer cannot be used. A set minute minder time continues to count down. The hob is programmed so that the system lock must be activated manually. The system lock can be programmed to be activated automatically 5 minutes after the hob has been switched off (see “Programming”).

The **safety lock** is activated when the hob is switched on. When the safety lock is activated, the hob can be operated only under certain conditions:

- The hob can only be switched off.
- Selected power levels **cannot** be changed.
- A set minute minder time can be modified.

If an unavailable sensor control is touched whilst the system lock or safety lock is activated, *LDC* will appear in the timer display for a few seconds and a tone will sound.

Activating the system lock

- Touch the ① sensor control for 6 seconds.

The seconds can be seen counting down in the timer display. When this time has elapsed, *LDC* will appear in the timer display. The system lock is activated.

Deactivating the system lock

- Touch the ① sensor control for 6 seconds.

LDC will appear briefly in the timer display and then the seconds will count down. The system lock is deactivated once the time has elapsed.

Activating the safety lock

- Touch and hold the ⊕ and II/► sensors at the same time for 6 seconds.

The seconds can be seen counting down in the timer display. When this time has elapsed *LDC* will appear in the timer display. The safety lock is activated.

Deactivating the safety lock

- Touch and hold the ⊕ and II/► sensors at the same time for 6 seconds.

LDC will appear briefly in the timer display and then the seconds will be seen counting down. Once the time has elapsed, the lock function is deactivated.

Safety switch-off

Sensor controls are covered

Your hob will turn off automatically if one or several of the sensors remain covered for longer than 10 seconds, for example, by finger contact, food boiling over or by an object such as an oven glove or tea towel. ① flashes briefly above the \mathcal{L} sensor control and a tone will sound.

\mathcal{L} will go out once you have removed the object and/or cleaned the hob and the hob will be ready to use again.

Excessive operating time

The safety shut-off is triggered automatically if a zone is heated for an unusually long period of time. This time depends on the power level selected. If it has been exceeded, the heat switches off and the residual heat indicator appears. A power level can be selected in the usual way.

The hob is programmed to safety setting 0 at the factory. If required you can set a higher safety setting with a shorter maximum operating time (see chart).

Power level*	Maximum operating time [h:min]		
	Safety setting		
	0**	1	2
1	10:00	8:00	5:00
1.	10:00	7:00	4:00
2/2.	5:00	4:00	3:00
3/3.	5:00	3:30	2:00
4/4.	4:00	2:00	1:30
5/5.	4:00	1:30	1:00
6/6.	4:00	1:00	0:30
7/7.	4:00	0:42	0:24
8	4:00	0:30	0:20
8.	4:00	0:30	0:18
9	1:00	0:24	0:10

* The power levels with a dot after the number are only available if the power level range has been extended (see “Setting ranges”).

** Factory default setting

Safety features

Overheating protection

All the induction coils and heat sinks for the electronic module are fitted with an overheating protection mechanism.

Before the induction coils or heat sinks get too hot, the overheating protection mechanism intervenes in one of the following ways:

Induction coils

- Any Booster function in operation will be switched off.
- The set power level will be reduced.
- The heating switches off automatically. *Err* will flash alternately with *044* in the timer display.

You can use the zone again as usual when the fault message has gone out.

Heat sink

- Any Booster function in operation will be switched off.
- The set power level will be reduced.
- The heating switches off automatically.

The affected zones can only be used again as usual once the heat sink has cooled down to a safe level.

The overheating protection may be activated under the following circumstances:

- The cookware being heated is empty.
- Fat or oil is being heated on a high power level.
- There is insufficient ventilation to the underside of the hob.
- A hot zone is switched on after an interruption to the power supply.

If, despite removing the cause, the overheating protection mechanism triggers again, contact your Miele Dealer.

You can adapt the programming of the hob to your personal needs. Several settings can be altered in succession.

After accessing programming mode, the ☺ symbol appears and *PC* will appear in the timer display. After a few seconds *P:01* (Programme 01) will flash alternately with *C:01* (Code) in the timer display.

Change programming

Accessing programming mode

The II/▶ sensor is located approx. 1 cm (index finger width) to the left of the ① sensor.

- **With the hob switched off**, touch the ① and II/▶ sensors at the same time until the ☺ symbol and *PC* appear in the timer display.

Setting a programme

For a two digit programme number you need to first set the tens position.

- Whilst the programme is visible in the display (e.g. *P:01*), touch the ☺ sensor repeatedly until the number for the programme you want appears in the display or touch the appropriate number on the numerical keybank.

Setting the code

- Whilst the code is visible in the display (e.g. *C:01*), touch the ☺ sensor repeatedly until the number for the code you want appears in the display or touch the appropriate number on the numerical keybank.

To save the settings

- While the programme is showing in the display (e. g. *P:01*) touch the ① sensor until the indicators go out.

To avoid saving the settings

- While the code is showing in the display (e. g. *C:01*) touch the ① sensor until the indicators go out.

Programming

Programme ¹		Code ²	Settings
P:01	Demo/showroom mode	C:00	Demo mode off
		C:01	Demo mode on ³
		C:02	Showroom mode on ³
P:02	Power management ⁴	C:00	Off
		C:01	3680 W
		C:02	3000 W
		C:03	2000 W
		C:04	1000 W
P:03	Factory default settings	C:00	Do not restore factory default settings
		C:01	Restore factory default settings
P:04	Number of power levels for cookware	C:00	9 power levels + Booster
		C:01	17 power levels + Booster ⁵
P:06	Audible tone when a sensor control is touched	C:00	Off ⁶
		C:01	Quiet
		C:02	Medium
		C:03	Loud
P:07	Timer buzzer	C:00	Off
		C:01	Quiet
		C:02	Medium
		C:03	Loud
P:08	System lock	C:00	System lock can only be activated manually
		C:01	System lock activated automatically
P:09	Maximum operating time	C:00	Safety setting 0
		C:01	Safety setting 1
		C:02	Safety setting 2

Programming

Programme ¹		Code ²	Settings
P:10	WiFi registration	C:00	Not active/deactivated
		C:01	Active but not configured
		C:02	Active and configured (cannot be selected; displays whether connection was successful)
		C:03	Connection possible via WPS push button
		C:04	WiFi reset to default (C:00)
		C:05	Direct WiFi connection of hob and cooker hood without Miele app (Con@ctivity 3.0)
P:12	Sensor controls reaction speed	C:00	Slow
		C:01	Normal
		C:02	Fast
P:14	Confirmation of power level when position of pan is changed	C:00	Confirmation necessary
		C:01	Confirmation not necessary

Programming

Programme ¹		Code ²	Settings
P:25	Keeping warm temperature	C:00	50 °C
		C:01	55 °C
		C:02	60 °C
		C:03	65 °C
		C:04	70 °C
		C:05	75 °C
		C:06	80 °C
		C:07	85 °C
		C:08	90 °C

¹ Programmes not shown here have no allocation.

² The factory default setting is shown in bold.

³ After the hob has been switched on, dE appears in the timer display for a few seconds.

⁴ The total output of the hob may be reduced in order to meet the local network provider's requirements.

⁵ In the text and tables, the extended power levels are shown with a dot after the number.

⁶ The confirmation tone of the On/Off sensor control cannot be switched off.

Safety notes on cleaning and care

 Risk of burns due to hot surfaces.

All parts of the hob may be hot after use.

Switch the hob off.

Allow the hob to cool down before cleaning it.

All surfaces could be discoloured or damaged if unsuitable cleaning agents are used or if residues from suitable cleaning agents are heated on the hob.

Allow the surfaces to cool down before cleaning the hob.

Remove all cleaning agent residues immediately.

Never use abrasive sponges or cleaning agents.

- ▶ Do not use a steam cleaner to clean the hob.
- ▶ Do not use pointed objects for cleaning.

Cleaning and care

When to clean

- Clean the hob after every use.

Removing light soiling

- Clean the entire ceramic surface of the hob with a damp, soft cloth and a solution of water and a little washing-up liquid. Please follow the cleaning agent manufacturer's instructions.

Removing stubborn soiling

- Remove any coarse soiling with a damp cloth and more stubborn soiling with a scraper suitable for use on glass.
- Clean the glass ceramic surface with the Miele ceramic and stainless steel cleaner (see "Optional accessories – Cleaning and care products") or with a proprietary ceramic glass cleaner. Please follow the cleaning agent manufacturer's instructions.

Finishing the cleaning process

- Remove all cleaning agent residues with a damp cleaning cloth.
- Dry the ceramic surface of the hob after cleaning.

Unsuitable cleaning agents

To avoid damaging the surfaces of the appliance, do not use:

- Cleaning agents containing soda, alkalines, ammonia, acids or chlorides
- Stain and rust removers
- Abrasive cleaning agents, e.g. powder cleaners and cream cleaners
- Cleaning agents containing solvents
- Dishwasher cleaning agents
- Oven sprays
- Hard, abrasive brushes
- Eraser stain remover blocks
- Sponges

Many malfunctions and faults that can occur in daily operation can be easily remedied. You can save time and money in many cases, as you do not need to call the the Miele Dealer.

The following tables are designed to help you to find the cause of a malfunction or a fault and to resolve it.

Messages in the display

Issue	Cause and remedy
<i>Err</i> is flashing alternately with 30 in the timer display and the buzzer is sounding.	The hob is incorrectly connected. <ul style="list-style-type: none"> ■ Disconnect the hob from the mains electricity supply. ■ Contact your Miele dealer. The hob must be connected to the mains according to the wiring diagram.
After the hob has been switched on, or after touching a sensor control, <i>L0C</i> appears in the timer display for a few seconds.	The system lock or safety lock is activated. <ul style="list-style-type: none"> ■ Deactivate the system lock or safety lock (see “Safety features – System lock/Safety lock”).
After the hob has been switched on, <i>dE</i> appears briefly in the timer display. The hob does not heat.	The hob is in demo mode. <ul style="list-style-type: none"> ■ Touch the 0 sensor control on any of the numerical displays. ■ Then touch the 0 and 2 sensor controls at the same time until <i>dE</i> flashes alternately with <i>0FF</i> in the timer display.
The hob has switched off automatically. When the hob is switched back on, <i>L</i> appears above the On/Off sensor control ①.	One or more of the sensor controls are covered, e.g. by finger contact, food boiling over or an object. <ul style="list-style-type: none"> ■ Clean off any dirt and/or remove the object (see “Safety features – Safety switch-off”).
<i>Err</i> will flash alternately with 044 in the timer display.	The overheating protection mechanism has been activated. <ul style="list-style-type: none"> ■ See “Safety features – Overheating protection”.

Problem solving guide

Issue	Cause and remedy
Err will flash alternately with <i>047, 048</i> or <i>049</i> in the timer display.	The fan is blocked or defective. <ul style="list-style-type: none">■ Make sure it has not been blocked by an object.■ Remove the obstruction.■ If this fault message continues to appear in the display, contact your Miele dealer.
In the timer display, E-digit, e.g. E-0, flashes alternately with <i>120, 121, 122, 123, 124, 125, 126, or 127.</i>	The fan is blocked or defective. <ul style="list-style-type: none">■ Make sure it has not been blocked by an object.■ Remove the obstruction.■ If this fault message continues to appear in the display, contact your Miele dealer.
A message not listed in this table is appearing in the timer display.	There is an electronic module fault. <ul style="list-style-type: none">■ Disconnect the power supply to the hob for approx. 1 minute.■ If the problem persists after power has been restored, please contact your Miele dealer.

Unexpected behaviour

Issue	Cause and remedy
<p>When you place a pot or a pan on the hob the corresponding numerical keybank does not appear.</p>	<p>The pan cannot be detected in this position because it is very small.</p> <ul style="list-style-type: none"> ■ Re-position the pan. If it is still not detected, use a different pan.
	<p>The pan is unsuitable.</p> <ul style="list-style-type: none"> ■ Use suitable pans (see “pans” in the “Induction” chapter).
<p>The  symbol lights up.</p>	<p>The pans are too close together.</p> <ul style="list-style-type: none"> ■ Re-position the pans. Move the pans one after the other, not all at the same time.
<p>You re-position a pan and the set power level starts to flash.</p>	<p>The pan cannot be detected.</p> <ul style="list-style-type: none"> ■ Touch the flashing power level. ■ If the power level continues to flash, re-position the pan.
<p>You re-position a pot or a pan, the set power level goes out and 0 lights up.</p>	<p>The pan cannot be detected.</p> <ul style="list-style-type: none"> ■ Reset the power level.
<p>A zone switches itself off automatically.</p>	<p>It has been operated for too long.</p> <ul style="list-style-type: none"> ■ Switch a power level back on again (see “Safety switch off” in the “Safety features” chapter).
<p>A zone is not working in the usual way on the power setting selected.</p>	<p>The overheating protection mechanism has been activated.</p> <ul style="list-style-type: none"> ■ See “Overheating protection” in the “Safety features” chapter.
<p>A zone or the whole hob switches off automatically.</p>	<p>The overheating protection mechanism has been activated.</p> <ul style="list-style-type: none"> ■ See “Overheating protection” in the “Safety features” chapter.
<p>The Booster has deactivated early automatically.</p>	<p>The overheating protection mechanism has been activated.</p> <ul style="list-style-type: none"> ■ See “Safety features”.

Problem solving guide

Unsatisfactory results

Issue	Cause and remedy
The food in the pan does not heat up when the Auto heat-up function is switched on.	A large amount of food is being heated up. ■ Start cooking at the highest power level and then turn down to a lower one manually later on.
	The pan is not conducting heat properly. ■ Use a different pot or pan which conducts heat properly.
In comparable cooking and frying processes there are slight differences in cooking durations and browning.	This is not a fault. The pan base material and the positions of the pans on the hob affect the power of the induction coils. This in turn affects the cooking behaviour.

General problems or technical faults

Issue	Cause and remedy
The hob cannot be switched on.	<p>There is no power to the hob.</p> <ul style="list-style-type: none">■ Check whether the fuse has tripped. Contact a qualified electrician or your Miele dealer (for the minimum fuse rating, see data plate). <p>There may be a technical fault.</p> <ul style="list-style-type: none">■ Disconnect the hob from the electricity supply for approx. 1 minute. To do this:<ul style="list-style-type: none">– trip the relevant fuse or screw the fuse out completely, or– switch off the residual current protection device■ If the appliance will still not turn on after resetting the trip switch in the fuse box or the residual current current device, contact your Miele dealer.
A smell and vapours are given off when the new appliance is being used.	<p>The metal components have a protective coating. When the appliance is used for the first time, this causes a smell and possibly also vapour. The material from which the induction coils are made also gives off a smell in the first few hours of operation. With each subsequent use, the odour is reduced until it disappears completely. The smell and any vapours given off do not indicate a faulty connection or appliance and they are not hazardous to health.</p>
An operating noise can be heard after the appliance has been switched off.	<p>The cooling fan runs until the hob has cooled down and then switches off automatically.</p>

Optional accessories

Miele offer a comprehensive range of useful accessories as well as cleaning and conditioning products for your Miele appliances.

These can be ordered from your Miele dealer (see end of this booklet for contact details).

Pans

Miele offer a wide range of cookware. These have all been optimised for Miele appliances in terms of functionality and dimensions. Please contact your Miele dealer for more details on individual products.

Cleaning and care products

Ceramic and stainless steel hob cleaner 250 ml

Removes heavy soiling, limescale deposits and aluminium residues.

Microfibre cloth

For removing finger marks and light soiling.

Information to help you rectify faults yourself and about Miele spare parts can be found at www.miele.com/service.

Contact in case of malfunction

In the event of any faults which you cannot remedy yourself, please contact your Miele dealer.

Contact details for your Miele dealer are given at the end of this document.

Please note that telephone calls may be monitored and recorded for training purposes and that a call-out charge will be applied to service visits where the problem could have been resolved as described in this booklet.

Please quote the model and serial number of your appliance when contacting your Miele dealer. This information can be found on the data plate.

Data plate

Stick the extra data plate supplied with the appliance here. Make sure that the model number matches the one specified on the back cover of this document.

Guarantee

For information on the appliance guarantee specific to your country please contact your Miele dealer. See end of this booklet for contact details.

Installation

Safety instructions for installation

 Risk of damage from incorrect connection.
Incorrect installation can cause damage to the hob.
The hob must only be installed by a qualified person.

 Risk of electric shock from mains voltage.
Incorrect connection to the mains supply may result in an electric shock.
The hob must be connected to the electrical supply by a qualified electrician only.

 Damage from falling objects.
Take care not to damage the hob when fitting wall units or a cooker hood above it.
Fit the wall units and the cooker hood before the hob.

- ▶ The veneer or laminate coatings of worktops (or adjacent kitchen units) must be treated with 100 °C heat-resistant adhesive which will not dissolve or distort. Any backmoulds must be of heat-resistant material.
- ▶ The hob must not be installed over a fridge, fridge-freezer, freezer, dishwasher, washing machine, washer-dryer or tumble dryer.
- ▶ This hob must not be installed above ovens or cookers unless these have a built-in cooling down fan.
- ▶ After installation, ensure that nothing can come into contact with the connection cable and that it is without hindrance.
- ▶ The electrical cable may not come into contact with any moving kitchen component (e.g. a drawer) or be subject to mechanical obstruction which could damage it.
- ▶ Observe carefully the safety clearances listed on the following pages.

Safety distances

Safety distance above the hob

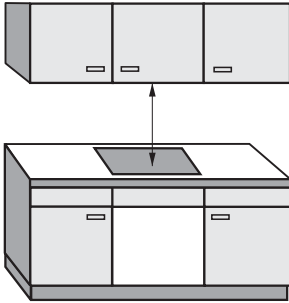

The safety distance specified by the manufacturer of the cooker hood must be maintained between the hob and the cooker hood above it.

If combustible objects are installed above the hob (e.g., cabinets, utensil rail, etc.), a minimum safety distance of 500 mm must be maintained.

When two or more appliances which have different safety distances are installed together below a cooker hood, you should observe the greatest specified safety distance.

Installation

Safety distances to the sides and back of the appliance

It is advisable to install the hob with plenty of space either side of it.

The minimum distance ① shown below must be maintained between the back of the hob and a tall unit or wall.

The minimum distance ②, ③ shown below must be maintained between a tall unit or a wall to the left or right of the hob with a minimum distance of 200 mm on the opposite side.

① Minimum distance between the **back** of the worktop cut-out and the rear edge of the worktop:
50 mm

② Minimum distance between the worktop cut-out and a wall or tall unit to the **right** of it:
50 mm.

③ Minimum distance between the worktop cut-out and a wall or tall unit to the **left** of it:
50 mm.

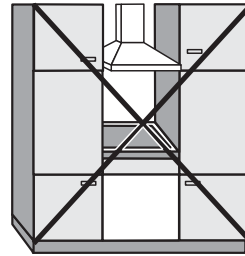

Not allowed

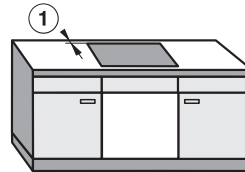
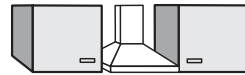

Highly recommended

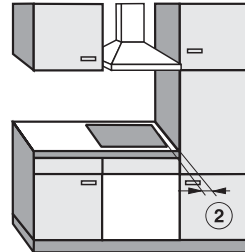

Not recommended

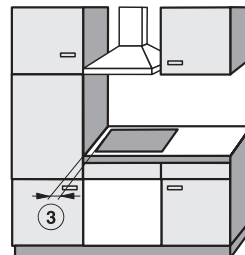

Not recommended

Minimum safety distance underneath the hob

To ensure sufficient ventilation to the hob, a minimum safety distance must be left between the underside of the hob and any oven, intermediate shelf or drawer.

The minimum safety distance between the underside¹ of the hob and

- Upper edge of oven: ≥ 8 mm
- Upper edge of intermediate shelf: ≥ 8 mm
- Upper edge of drawer: ≥ 8 mm
- Base of drawer: ≥ 75 mm

¹ The underside is the outside of the hob casing. Other items that are attached lower down, such as connection boxes and shims, do not count as the lowest point and are not relevant when calculating the minimum safety distance.

Intermediate shelf

It is not necessary to fit an intermediate shelf underneath the hob, but one may be fitted if you wish.

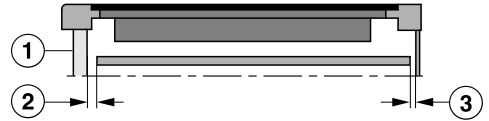

Side view

- ① Front
- ② Gap, front
- ③ Gap, back

A gap ② of 20 mm is recommended at the front between the cabinet and intermediate shelf for better **ventilation** of the hob.

Leave a gap ③ of 30 mm at the back between the cabinet and the intermediate shelf to **accommodate the mains connection cable**.

Installation

Safety distance to niche cladding

If niche cladding is installed, a minimum safety distance must be maintained between the worktop cut-out and the cladding, since high temperatures can alter or damage these materials.

If the niche cladding is made from a combustible material (e.g. wood), a minimum safety distance ⑤ of 50 mm must be maintained between the worktop cut-out and the cladding.

If the niche cladding is made from a non-combustible material (e.g. metal, natural stone, ceramic tiles), the minimum safety distance ⑤ between the worktop cut-out and the cladding will be 50 mm minus the thickness of the cladding.

Example: 15 mm thick niche cladding

50 mm – 15 mm = minimum safety distance of 35 mm

Flush-fit installation

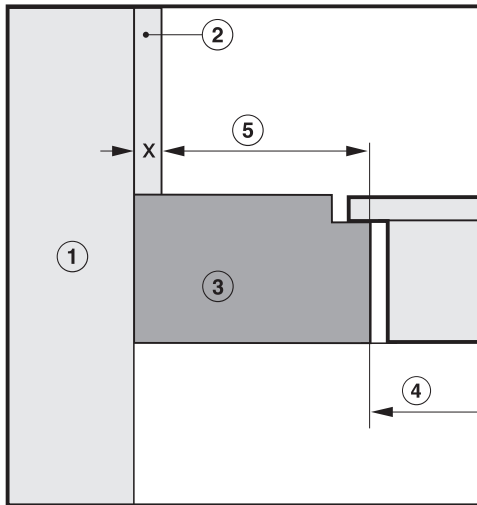

Surface-mounted installation

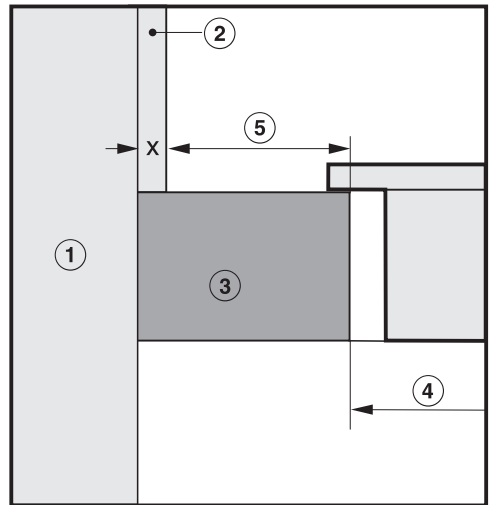

- ① Masonry
- ② Niche cladding dimension x = thickness of the niche cladding material
- ③ Worktop
- ④ Worktop cut-out
- ⑤ Minimum safety distance to
combustible materials 50 mm
non-combustible materials 50 mm – dimension x

Installation notes – surface-mounted

Seal between the hob and the worktop

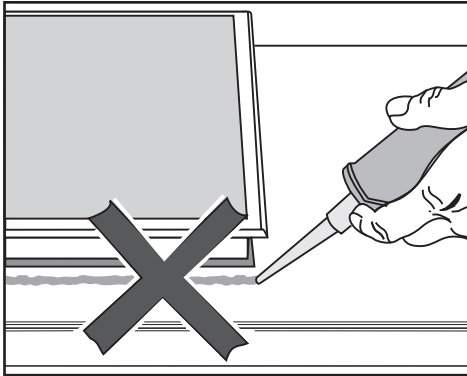

 Damage caused by incorrect installation.

Using sealant under the hob could result in damage to the hob and the worktop if the hob ever needs to be removed for servicing.

Do not use sealant between the hob and the worktop.

The sealing strip under the edge of the hob provides a sufficient seal for the worktop.

Sealing strip

Dismantling the hob for service purposes may damage the sealing strip underneath the edge of the hob.

Always replace the sealing strip before reinstalling the hob.

Tiled worktops

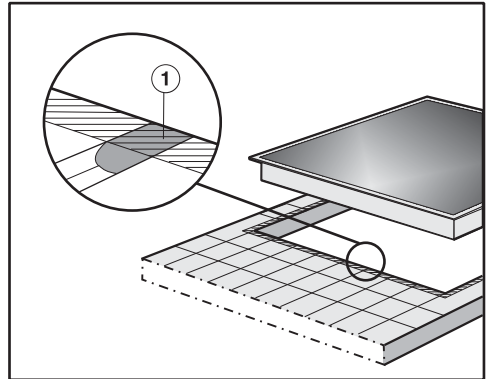

Grout lines ① and the hatched area underneath the hob frame must be smooth and even. If they are not the hob will not sit flush with the worktop and the sealing strip underneath the hob will not provide a good seal between the hob and the worktop.

Do not install DiamondFinish hobs in front of a window

The installation of DiamondFinish models in front of a window is not recommended.

Direct sunlight causes the surface to reflect more intensely and makes the displays harder to see.

Installation

Installation dimensions – Surface-mounted

All dimensions are given in mm.

KM 7678-2 FL, KM 7878-2 FL Diamond

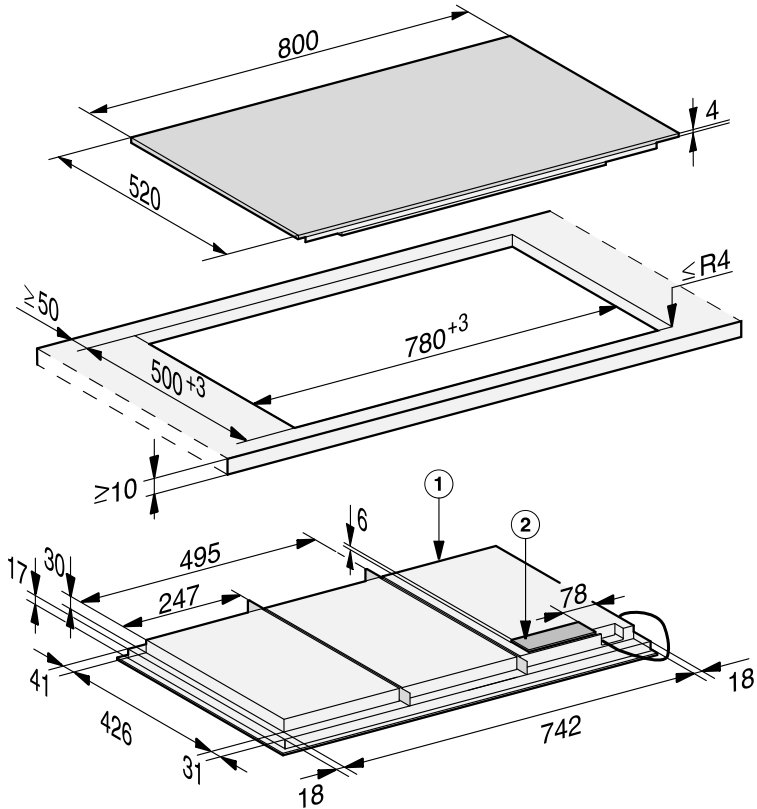

① Front

② Mains connection box

The mains connection cable (L = 1440 mm) is supplied loose

KM 7897-2 FL Diamond

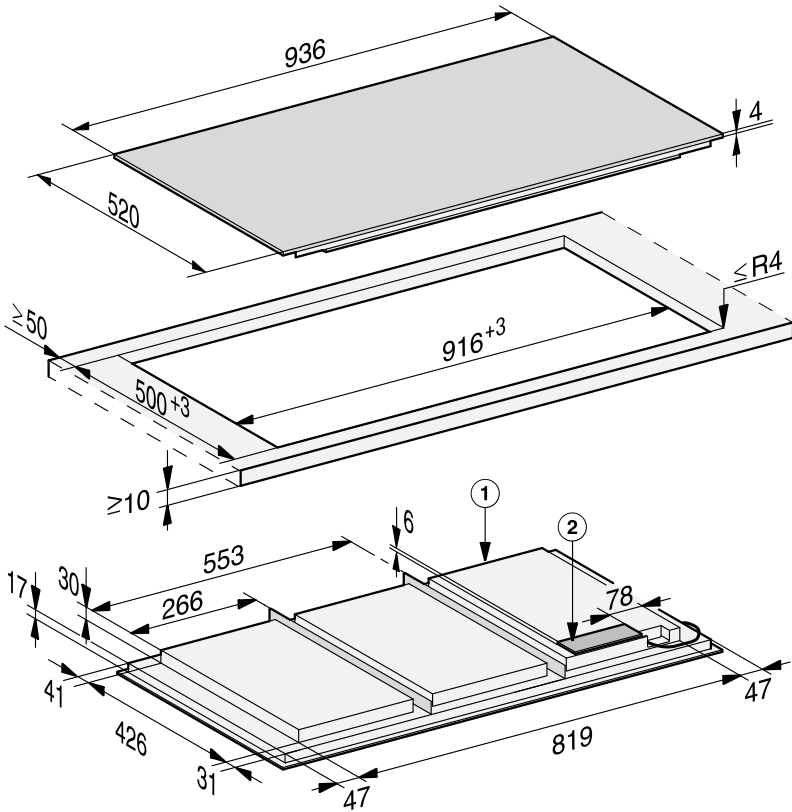

① Front

② Mains connection box

The mains connection cable (L = 1440 mm) is supplied loose

Installation

Surface-mounted installation

- Create the worktop cut-out.
Remember to maintain the minimum safety distances (see “Installation – Safety distances”).
- Seal any cut surfaces on **wooden worktops** with a special varnish, silicone sealant or resin to prevent the wood from swelling as a result of moisture ingress. The sealant must be heat-resistant.

Make sure that the sealant does not come into contact with the top of the worktop.

- Stick the supplied sealing strip under the edge of the hob. Do not apply the sealing strip under tension.



Risk of damage from incorrect connection.

The hob electronics may be damaged if a short-circuit occurs.

The power cable must be connected to the hob by a qualified electrician.

- Connect the power cable by following the instructions in the wiring diagram on the hob (see “Installation – Electrical connection”).
- Feed the power cable for the hob down through the worktop cut-out.
- Place the hob centrally in the cut-out. When doing this, make sure that the seal of the appliance sits flush with the worktop on all sides. This is important to ensure an effective seal all round.

If the seal does not sit flush with the worktop in the corners, the corner radius ($\leq R4$) can be carefully cut to fit using a jigsaw.

- Connect the hob to the electricity supply (see “Installation – Electrical connection”).
- Check that the hob works.

Installation notes – flush-fit

A flush-fit hob is suitable only for installation in natural stone (granite, marble), solid wood and tiled worktops. Certain models are also suitable for building into glass worktops – these are marked with an appropriate note in “Installation – Installation dimensions – flush-fit”. When using a worktop made from any other material, please check first with the worktop manufacturer that it is suitable for installing a flush-fit hob.

The internal width of the base unit underneath the appliance must be at least as wide as the inner worktop cut-out (see “Installation – Installation dimensions – flush fit”), so that the hob is easily accessible from underneath after installation and the casing can be removed for maintenance. If the underside of the hob is not freely accessible after installation, any sealant used must be removed to enable the hob to be lifted out of the cut-out should this be necessary.

Natural stone worktops

The hob is set directly in the cut-out.

Solid wood worktops, tiled worktops, glass worktops

The hob is secured inside the cut-out with wooden battens. The battens must be provided on site, and are not supplied with the appliance.

Sealing strip

Dismantling the hob for service purposes may damage the sealing strip underneath the edge of the hob. Always replace the sealing strip before reinstalling the hob.

Do not install DiamondFinish hobs in front of a window

The installation of DiamondFinish models in front of a window is not recommended. Direct sunlight causes the surface to reflect more intensely and makes the displays harder to see.

Installation

Flush-fit installation

- Create the worktop cut-out.
Remember to maintain the minimum safety distances (see “Safety distances”).
- Solid wood, tiled and glass worktops:
Fix a wooden frame 5,5 mm below the top edge of the worktop.

 Risk of damage from incorrect connection.

The hob electronic module may be damaged if a short-circuit occurs.
The mains connection cable must be connected to the hob by a qualified electrician.

- Connect the electrical connection cable by following the instructions in the wiring diagram on the hob (see “Wiring diagram” in the “Electrical connection” chapter).
- Stick the supplied sealing strip under the edge of the hob. Do not apply the sealing strip under tension.
- Feed the mains connection cable for the hob down through the worktop cut-out.
- Centre the hob in the cut-out.

The gap between the ceramic glass surface and the worktop must be at least 2 mm wide. This is required so that the hob can be sealed.

- Connect the hob to the electricity supply (see “Electrical connection”).
- Check that the hob works.

- Seal the gap between the hob and worktop with a silicone sealant that is heat-resistant to at least 160 °C.

 Damage from unsuitable sealant.
Unsuitable sealant can damage natural stone.
For natural stone worktops and natural stone tiles, only use silicone sealant that is specially formulated for natural stone. Follow the manufacturer’s instructions.

Electrical connection

 Risk of damage from incorrect connection.

Unauthorised installation, maintenance and repairs can cause considerable danger for the user.

Miele cannot be held liable for damage or injury caused by unauthorised installation, maintenance or repair work, or by an inadequate or faulty on-site earthing system (e.g. electric shock).

This hob must be connected to the electrical supply by a qualified electrician.

The electrician must be familiar with and comply with the national regulations and any additional regulations of the local electricity provider.

After installation, ensure that all electrical components are shielded and cannot be accessed by users.

Total power rating

See data plate

Connection data

The connection data is quoted on the data plate. Please ensure these match the household mains supply.

Please see wiring diagrams for connection.

Disconnecting devices

It must be possible to disconnect the hob from the mains at all poles using disconnecting devices. A contact distance of at least 3 mm must be observed in the switched-off state. The disconnecting devices are overcurrent protection devices and residual current protection devices.

Installation

Disconnecting from the mains



Risk of electric shock.

There is a risk of electric shock if the appliance is connected to the mains supply during repair or service work.

After disconnection, ensure the appliance cannot be switched back on by mistake.

To disconnect the appliance from the mains power supply, do one of the following depending on installation:

Safety fuses

- Completely remove fuses.

Automatic circuit breakers

- Press the (red) test button until the middle (black) button springs out.

Built-in circuit breakers

- Circuit breakers at least type B or C:
Switch the lever from 1 (on) to 0 (off).

Residual current device (RCD)

- Switch the main switch from 1 (on) to 0 (off) or press the test button.

Mains connection cable

The hob must be connected to the electrical supply with a special connection cable, type H 07 RN-F with a suitable diameter.

Please see wiring diagrams for connection. (N.B. This appliance is supplied single phase only in the UK / AUS / NZ).

See the data plate on the hob for the correct voltage and rated load.

Replacing the mains connection cable



Risk of electric shock.

Incorrect connection to the power supply may result in an electric shock.

The mains cable must only be replaced by a qualified electrician.

When replacing the mains cable only use cable type H 07 RN-F with a suitable cross section. A suitable connection cable is available from your Miele dealer.

Wiring diagram

Some connection methods are not permitted in all installation locations. Ensure compliance with national regulations and any additional regulations issued by the local electricity provider.

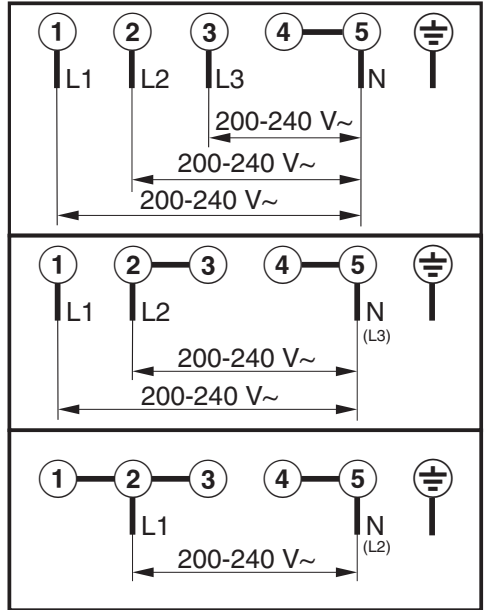

Miele in Saudi Arabia:

Awad Badi Nahas Trading Co. Ltd.

Medina Road, P.O. Box 11529
Jeddah 21463
Kingdom of Saudi Arabia
Tel. +966 12 2560888
Hotline for customer care 920003240
(Sat – Thu; 8 am – 5 pm)
Fax +966 12 2560555
E-mail: info@awadnahas.com
Website: www.awadnahas.com

Miele in United Arab Emirates:

Miele Appliances Ltd.

Showroom 1 Eiffel 1 Building
Sheikh Zayed Road, Umm Al Sheif
P.O. Box 114782 - Dubai
United Arab Emirates
Tel. +971 4 3044 999
Fax +971 4 3418 852
800-MIELE (64353)
E-mail: info@miele.ae
Website: www.miele.ae
Webshop: shop.miele.ae

Miele in Kuwait:

Al Wazzan United Trading Co.

P. O. Box : 3379 Hawally 32034
Kuwait
Tel. 00965-22001010
Fax 00965-24838292
E-mail: mail@alwazzanunited.com
Website: www.alwazzanunited.com

Miele in Egypt:

B.Tech for Trade and Distribution

Ramses Extension, 6th Zone,
Nasr City - Cairo
Egypt
Tel. +202 23480700/15
Customer service contact: 15997
Fax +202 23426076
E-mail: info@btech.com
Website: www.mieleegypt.com

Manufacturer: Miele & Cie. KG, Carl-Miele-Straße 29, 33332 Gütersloh, Germany

KM 7678-2 FL, KM 7878-2 FL Diamond,
KM 7897-2 FL Diamond