

Operating instructions Coffee maker



To avoid the risk of accidents or damage to the appliance, it is **essential** to read these instructions before it is installed and used for the first time.

Caring for the environment

Disposal of the packing material

The packaging material protects the appliance from transport damage. The packaging materials used are selected from materials which are environmentally friendly for disposal and should be recycled.

Recycling the packaging reduces the use of raw materials in the manufacturing process and also reduces the amount of waste in landfill sites. Ensure that any plastic wrappings, bags etc. are disposed of safely and kept out of the reach of babies and young children. Danger of suffocation!

Saving energy

The following tips can help you save energy and money as well as care for the environment:

- Operate the coffee machine in Eco mode (default setting).
- Select a low display brightness.
- Switch off the lighting switch-off time when the appliance is switched off.
- Switch off the time of day display.
- Change the setting for the Switch off after timer to 20 minutes. The coffee machine will then switch itself off 20 minutes after the last drink was made or a sensor was touched. If you increase the setting for the Switch off after timer, the energy consumption of the coffee machine will increase.
- Some changes to the factory default settings may increase the energy consumption of the coffee machine. Pay particular attention to the following message in the display: This setting uses more energy

- If you only want to pre-heat your cups occasionally, you can switch the cup heating surface off.
- Switch the coffee machine off with the On/Off Ⓛ sensor if it is not going to be used for a while.

Disposing of your old appliance

Electrical and electronic appliances often contain valuable materials. They also contain specific materials, compounds and components, which were essential for their correct function and safety. These could be hazardous to human health and to the environment if disposed of with your domestic waste or if handled incorrectly. Please do not, therefore, dispose of your old appliance with your household waste.



Please dispose of it at your local community waste collection / recycling centre for electrical and electronic appliances. You are also responsible for deleting any personal data that may be stored on the appliance prior to disposal. Please ensure that your old appliance poses no risk to children while being stored prior to disposal.

| | |
|--|-----------|
| Caring for the environment | 2 |
| Saving energy..... | 2 |
| Warning and Safety instructions | 7 |
| Guide to the appliance | 16 |
| Appliance front..... | 16 |
| Rear of machine..... | 17 |
| Central spout in detail | 18 |
| Milk flask and milk siphon | 18 |
| Milk flask in detail..... | 18 |
| Connecting piece for milk siphon and milk flask..... | 18 |
| Symbols in the display..... | 19 |
| Operating principles | 21 |
| Touch display..... | 21 |
| Operating actions | 21 |
| Miele@home | 23 |
| Unpacking and installing | 24 |
| Unpacking the coffee machine..... | 24 |
| Accessories supplied | 24 |
| Installing and connecting the coffee machine | 24 |
| Before using for the first time | 26 |
| Fitting the descaling cartridge | 26 |
| Setting the water hardness level..... | 27 |
| Confirming connectivity of the appliance | 27 |
| Setting up the bean system..... | 27 |
| Bean system | 29 |
| Changing bean system settings (Type of beans)..... | 29 |
| Renaming type of beans | 29 |
| Changing bean type allocation..... | 30 |
| Filling the water container | 31 |
| Switching on and off | 32 |
| Switching the coffee machine on..... | 32 |
| Switching the coffee machine off | 32 |
| Preparing for an extended period of inactivity | 32 |
| Central spout with cup rim sensor | 33 |
| Moving the central spout into the maintenance position | 33 |
| Switching the spout adjustment on and off | 33 |
| Cup heating | 34 |
| Pre-heating cups | 34 |

Contents

| | |
|---|-----------|
| Making drinks | 35 |
| Coffee..... | 35 |
| Coffee drinks in detail | 35 |
| Milk and milk alternatives..... | 35 |
| Using a milk carton with the milk siphon | 37 |
| Making a coffee drink..... | 38 |
| Cancelling preparation | 38 |
| DoubleShot..... | 38 |
| Making two portions ☐..... | 38 |
| Coffee pot: making several cups of coffee one after the other..... | 39 |
| Making drinks with ready ground coffee | 39 |
| Tea | 40 |
| TeaTimer..... | 41 |
| Making tea | 41 |
| Cancelling tea preparation..... | 42 |
| Teapot: making several cups of tea one after the other | 42 |
| Preparing hot water..... | 42 |
| Parameters | 43 |
| Amount of coffee | 43 |
| Brewing temperature for coffee drinks..... | 43 |
| Pre-brewing ground coffee | 43 |
| Bean type..... | 43 |
| Grinder setting | 44 |
| Identifying the correct grinder setting..... | 44 |
| Adjusting the grinder setting | 44 |
| Portion size | 45 |
| Changing the portion size | 45 |
| Resetting drink settings | 46 |
| User profiles | 47 |
| Creating a profile | 47 |
| Calling up a profile..... | 47 |
| Editing a profile | 47 |
| Creating a drink in a profile | 48 |
| Changing a drink: Changing the portion size(s), drink parameters and names..... | 48 |
| Making a drink from a profile | 48 |
| Expert mode | 49 |
| Settings | 50 |
| Opening the "Settings" menu..... | 50 |
| Changing and saving settings..... | 50 |
| Language..... | 50 |

| | |
|---|-----------|
| Time of day | 50 |
| Timer | 51 |
| Switch on at | 51 |
| Switch off at | 51 |
| Switch off after | 51 |
| Allocating days of the week | 51 |
| Eco mode | 52 |
| Lighting | 52 |
| Water hardness | 52 |
| Info (display information) | 52 |
| System lock  | 52 |
| Miele@home | 53 |
| Display brightness | 53 |
| Volume | 53 |
| Service | 53 |
| Evaporating the coffee machine | 53 |
| Demo mode | 53 |
| Factory default settings | 53 |
| Appliance settings | 54 |
| Network configuration | 54 |
| Network | 55 |
| Setting up the network (Miele@home) | 55 |
| Setting up the network again | 55 |
| Remote control | 55 |
| Preparing MobileStart | 56 |
| Switching MobileStart on and off | 56 |
| RemoteUpdate | 57 |
| Cleaning and care | 58 |
| Cleaning intervals - Quick guide | 58 |
| Cleaning by hand or in the dishwasher | 59 |
| Unsuitable cleaning agents | 60 |
| Cleaning the drip tray and waste container | 60 |
| Cleaning the drip tray cover | 61 |
| Cleaning the water container | 62 |
| Removing and cleaning the water container filter | 62 |
| Cleaning the central spout | 63 |
| Cleaning the steam jet | 64 |
| Cleaning the cup rim sensor | 64 |
| Cleaning the milk siphon | 65 |
| Cleaning the milk flask | 65 |
| Cleaning the milk pipework manually or using the maintenance programme | 66 |
| Cleaning the bean system | 66 |

Contents

| | |
|---|-----------|
| Cleaning the ground coffee drawer..... | 67 |
| Vacuuming out the ground coffee chute..... | 67 |
| Cleaning the housing..... | 68 |
| Maintenance programmes..... | 68 |
| Opening the “Maintenance” menu..... | 68 |
| Rinsing the appliance..... | 68 |
| Rinsing the milk pipework..... | 69 |
| Cleaning the milk pipework..... | 69 |
| Degreasing the brew unit..... | 70 |
| Descaling the appliance..... | 72 |
| Automatic descaling..... | 75 |
| Please note before and during automatic descaling:..... | 75 |
| The Miele descaling cartridge..... | 76 |
| Removing the descaling cartridge..... | 77 |
| When not using a descaling cartridge..... | 78 |
| Start time for automatic descaling (Descaling timer)..... | 79 |
| Setting the start time for automatic descaling..... | 79 |
| Cancelling automatic descaling..... | 79 |
| Problem solving guide..... | 80 |
| Messages in the display..... | 80 |
| Unusual performance of the coffee machine..... | 83 |
| Faults with automatic descaling..... | 88 |
| Unsatisfactory results..... | 89 |
| Service..... | 91 |
| Contact in case of fault..... | 91 |
| Warranty..... | 91 |
| Transporting the machine..... | 92 |
| Evaporating the coffee machine..... | 92 |
| Vacuuming out the ground coffee chute using the attachment and cleaning the interior..... | 93 |
| Packing the coffee machine securely..... | 93 |
| Accessories..... | 94 |
| Electrical connection..... | 95 |
| Appliance dimensions..... | 96 |
| Technical data..... | 97 |

Warning and Safety instructions

This coffee machine complies with all current local and national safety requirements. However, inappropriate use can lead to personal injury and damage to property.

Read the operating instructions carefully before using the coffee machine. They contain important information on the installation, safety, use and maintenance of the appliance. Familiarity with these instructions will help to prevent personal injury and damage to property.

In accordance with standard IEC 60335-1, Miele expressly and strongly advises that you read and follow the instructions in "Installation", "Electrical connection", as well as in the "Warning and Safety instructions".

Miele cannot be held liable for injury or damage caused by non-compliance with these instructions.

Keep these instructions in a safe place and pass them on to any future owner.

Warning and Safety instructions

Correct application

- ▶ The coffee machine is intended for use in private households.
- ▶ The machine is intended only for the preparation of drinks such as espresso, cappuccino, latte macchiato, tea etc. Any other usage is at the owner's risk.
- ▶ The coffee machine is not suitable for outdoor use.
- ▶ This coffee machine must not be used at altitudes above 2,000 m.
- ▶ This appliance is not intended for use by persons (including children) with reduced physical, sensory or mental capabilities, or lack of experience and knowledge, unless they have been given supervision or instruction concerning its use by a person responsible for their safety, and are able to recognise the dangers of misuse.

Safety with children

 Danger of burning and scalding on the dispensing spouts.

Children's skin is far more sensitive to high temperatures than that of adults.

Ensure children do not touch hot surfaces of the coffee machine or place parts of their body under the dispensing spouts.

- ▶ Install the coffee machine out of reach of children.
- ▶ Young children must be kept away from the coffee machine and the mains connection cable and plug/socket.
- ▶ Older children may only use the coffee machine if its operation has been clearly explained to them and they are able to use it safely. They must be aware of the potential dangers caused by incorrect operation.
- ▶ Children should be supervised when they are near the coffee machine. Do not allow them to play with it or to use the controls.
- ▶ Young children must not be allowed to clean the coffee machine. Cleaning may only be carried out by older children under the supervision of an adult.
- ▶ Remember that coffee and espresso are not suitable drinks for children.
- ▶ Danger of suffocation! Whilst playing, children may become entangled in packaging material (such as plastic wrapping) or pull the packaging material over their head, presenting the risk of suffocation. Keep packaging material away from children.

Warning and Safety instructions

Technical safety

- ▶ A damaged coffee machine is dangerous. Check it for any visible damage before setting it up. Never attempt to use a damaged coffee machine.
- ▶ Before connecting the appliance to the mains supply, make sure that the rating on the data plate corresponds to the voltage and frequency of the household supply. This data must correspond in order to avoid the risk of damage to the appliance. Consult a qualified electrician if in any doubt.
- ▶ The electrical safety of this appliance can only be guaranteed when continuity is complete between it and an effective earthing system. It is most important that this basic safety requirement is present and tested regularly and, where there is any doubt, the household wiring system should be inspected by a qualified electrician.
- ▶ Temporary or permanent operation with a self-sufficient or non-mains synchronous energy supply system (e.g. isolated networks, back-up systems) is possible. A requirement for the operation is that the energy supply system complies with all current local and national requirements that apply to stand-alone, solar and/or battery systems. The protective measures provided in the installation and in this Miele product must also be assured in their function and operation in isolated operation or in non-mains synchronous operation, or replaced with equivalent measures in the installation.
- ▶ Do not connect the machine to the mains electricity supply by a multi-socket adapter or an extension lead. These do not guarantee the safety of the appliance (e.g. danger of overheating).
- ▶ This appliance must not be installed and operated in mobile installations (e.g. on a ship).
- ▶ Unplug the coffee machine from the power supply immediately if you notice any damage or smell scorching, for example.
- ▶ Ensure that the mains connection cable cannot be pinched or damaged by any sharp edges.
- ▶ The mains connection cable should not hang down. Someone could trip over it with the risk of injury and the machine could be damaged.
- ▶ Only use the coffee machine in rooms where the ambient temperature is between +16 °C and +38 °C.

Warning and Safety instructions

- ▶ Do not place the coffee machine near a window in direct sunshine or right next to an appliance that gives off heat. These would subject the machine to ambient temperatures outside its permitted operating range.
- ▶ Position the coffee machine at a height of at least 850 mm from the floor.
- ▶ Danger of overheating! Ensure that there is sufficient ventilation around the coffee machine. Do not cover the coffee machine with tea towels etc. while it is in use.
- ▶ The coffee machine must not be installed in a niche. Heat and moisture can accumulate in a niche or a cupboard either with or without a furniture door. This can result in damage to the appliance and/or furniture unit.
- ▶ Protect the coffee machine from water and water spray. Do not immerse the machine in water.
- ▶ Repairs and other work by unqualified persons to the machine and the connection cable could be dangerous. The manufacturer cannot be held liable for unauthorised work. Repairs may only be carried out by a Miele authorised service technician.
- ▶ The manufacturer's warranty may be invalidated if the appliance is not repaired by a Miele approved service technician.
- ▶ Before any repair work is carried out, the appliance must be completely disconnected from the electricity supply. The appliance is only completely isolated from the electricity supply when:
 - it is switched off at the wall socket and the plug is withdrawn from the socket. Do not pull the mains connection cable but the mains plug to disconnect your appliance from the mains electricity supply.
 - the mains circuit breaker is switched off.
- ▶ Never open the outer casing of the machine. Tampering with electrical connections or components and mechanical parts is highly dangerous to the user and can cause operational faults or electric shock.
- ▶ Disconnect the coffee machine from the power supply if it is not going to be used for a while, e.g. while on holiday.

Warning and Safety instructions

Correct use

 Danger of burning and scalding on the dispensing spouts. The liquids and steam dispensed are very hot. Heating surfaces have residual heat after use.

Keep well away from the area underneath the spouts when hot liquids and steam are being dispensed.

Do not touch hot components.

Hot liquid or steam could spatter from the spouts. Ensure that the central spout is clean and fitted correctly.

Water in the drip tray can also be very hot. Take care when emptying it.

 Risk of injury to the eyes!

Never look directly at the lighting or use optical instruments (magnifying glass or similar) to look at it.

▶ Please note the following regarding water:

- The water quality must conform to the requirements for drinking water in the country in which the coffee machine is being used.
- Only use cold, fresh tap water to fill the water container. Hot or warm water or other liquids can damage the coffee machine.
- Change the water every day to prevent a build-up of bacteria.
- Do not use carbonated water.

▶ Only fill the bean container with roasted espresso or coffee beans. Do not fill the bean container with coffee beans which have been treated, e.g flavoured or caramelised, or with ground coffee.

▶ Do not fill the bean container with any type of liquid.

▶ Do not use green (unroasted) coffee beans or mixtures of coffee beans which contain green coffee beans. Green coffee beans are very hard and still contain residual moisture. These can damage the coffee machine grinder as soon as grinding begins.

▶ Do not use coffee beans which have been treated with caramel, sugar or other substances. Sugar will damage the coffee machine.

▶ Only fill the coffee chute with ground coffee beans.

Warning and Safety instructions

- ▶ Do not use any caramelised ready ground coffee. The sugar in the coffee will stick to and block the brew unit of the coffee machine. The cleaning tablets for degreasing the brew unit will not remove this type of deposit.
- ▶ If decaffeinated coffee beans are used after dispensing a drink with caffeinated beans, there may still be residues from the caffeinated beans in the grinder or brew chamber. Discard the first coffee drink when using decaffeinated coffee.
- ▶ Only use milk without additives. Additives in milk usually contain sugar and this will stick to the milk pipework.
- ▶ If using cow's milk, only use pasteurised milk to prevent a build-up of bacteria in the appliance.
- ▶ When making tea, please follow the instructions on the packaging.
- ▶ Do not place flaming alcohol mixtures underneath the central spout. The flames could ignite plastic components and cause them to melt.
- ▶ Do not use naked flames, e.g. a candle, on or near the coffee machine. The coffee machine could catch fire with the risk of the fire spreading.
- ▶ The machine must not be used for cleaning objects.

Accessories and spare parts

- ▶ Miele can only guarantee the safety of the appliance when original Miele spare parts are used. Faulty components must only be replaced by original Miele spare parts.
- ▶ Only use original Miele spare parts and accessories. If other spare parts and accessories are used, warranty, performance and/or product liability claims will be invalidated and Miele cannot accept liability.
- ▶ Miele will guarantee to supply functional spare parts for a minimum of 10 years and up to 15 years following the discontinuation of your coffee machine.

Warning and Safety instructions

Cleaning and care

- ▶ Disconnect the coffee machine from the power supply before cleaning.
- ▶ Clean the coffee machine and the milk flask daily, particularly before using for the first time.
- ▶ All parts of the milk system need to be cleaned thoroughly and regularly. Milk contains bacteria which proliferate rapidly with inadequate cleaning.
- ▶ Do not clean the machine with a steam cleaner or immerse it in water as this will damage the machine. Steam or water could reach the electrical components and cause a short circuit.
- ▶ If you do not utilise automatic descaling, you will need to descale the coffee machine manually on a regular basis. Miele cannot be held liable for damage resulting from not descaling the machine, using the wrong descaling agent or an unsuitable descaling solution concentration.
- ▶ Degrease the brew unit regularly with Miele cleaning tablets. Depending on the natural oil content of the coffee used, the brew unit can become blocked quite quickly.
- ▶ Used coffee grounds should be disposed of with the organic rubbish or on the compost heap. Do not empty them down the sink, as they could block it.

Warning and Safety instructions

The following applies to appliances with stainless steel surfaces:

- ▶ Do not adhere stickers, adhesive tape or any other adhesive materials to the stainless steel surfaces.
- ▶ Stainless steel scratches very easily and even magnets can cause damage to the surface.

Guide to the appliance

Appliance front

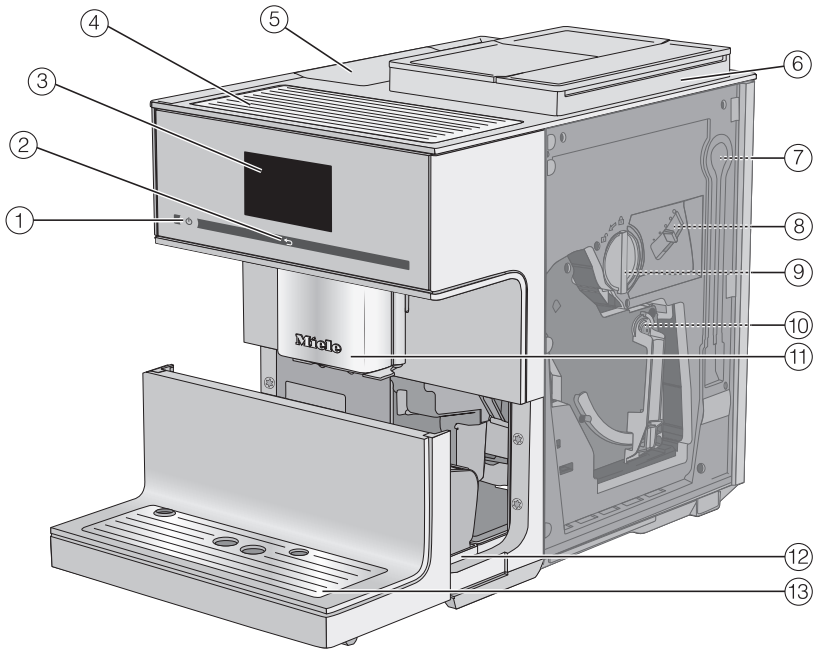

- ① On/Off ① sensor
- ② “Back” ← sensor
- ③ Touch display
- ④ Cup heating
- ⑤ Water container
- ⑥ Bean system with 3 bean containers
- ⑦ Park position for milk tube (behind the appliance door)
- ⑧ Grinder setting
- ⑨ Ground coffee drawer with integrated coffee scoop
- ⑩ Brew unit
- ⑪ Height-adjustable central spout with lighting
- ⑫ Drip tray with lid and waste container
- ⑬ Lower panel with drip tray cover

Rear of machine

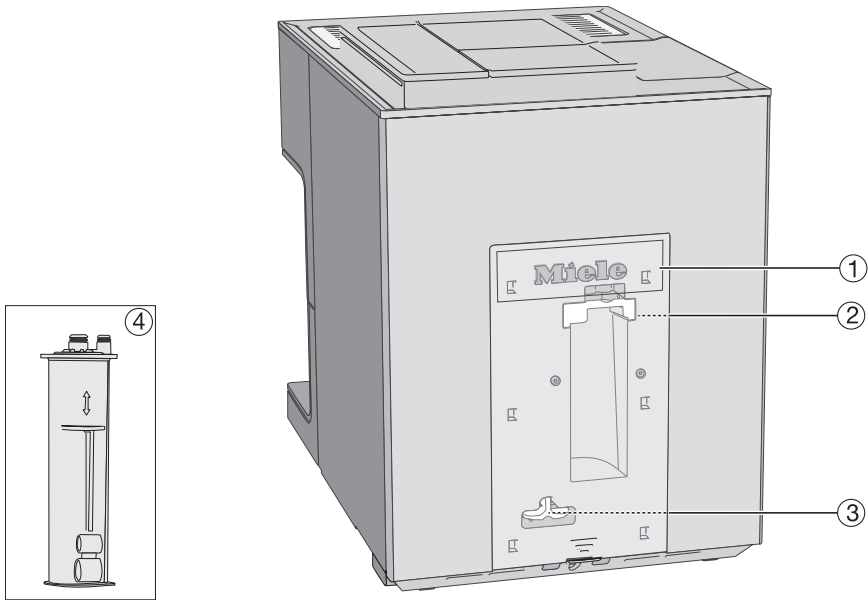

- ① Cover
- ② Descaling cartridge holder
- ③ Plug
- ④ Miele descaling cartridge

Guide to the appliance

Central spout in detail

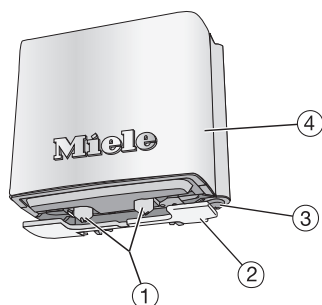

- ① Spouts for coffee and milk (dispensers)
- ② Cup sensor
- ③ Hot water spout
- ④ Stainless steel cover

Milk flask and milk siphon

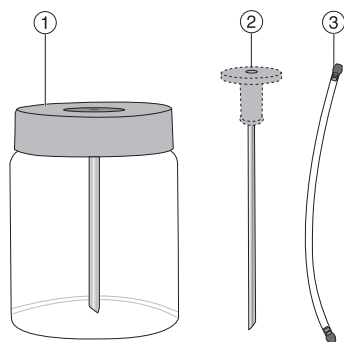

- ① Milk flask
- ② Milk siphon
- ③ Milk tube

Milk flask in detail

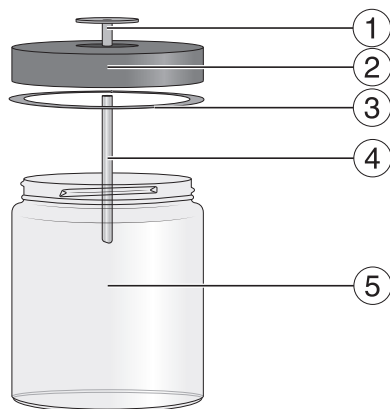

- ① Connecting piece
- ② Lid
- ③ Sealing ring
- ④ Stainless steel tube
- ⑤ Glass

Connecting piece for milk siphon and milk flask



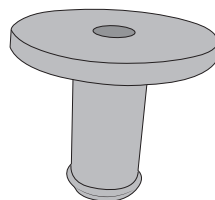





You can prepare milk with the milk siphon or milk flask.











The connecting piece is supplied as standard and is inserted into either the milk siphon or the lid of the milk flask. The appliance is supplied with the connecting piece already inserted into the milk flask lid. The connecting piece is easy to push out from the inside of the milk flask lid.

Symbols in the display

The following symbols may also appear in the display in addition to the text and drinks symbols:

| Symbol | Explanation |
|---|--|
|  | This symbol indicates the “Settings” menu and the “Language” menu option. |
|  | Some settings, e.g. display brightness and buzzer/keypad volume, are selected using a bar chart. |
|  | This symbol indicates that there is additional information and advice about using the coffee machine. Select <i>OK</i> to confirm the messages. |
|  | The Switch on at timer is activated (see “Settings - Timer”). The symbol and the desired switching on time appear in the display 23:59 hours before the coffee machine is due to switch on, as long as On or Night dimming is selected for the time display. |
|  | The TeaTimer minute minder has been started (see “Tea - TeaTimer”). The remaining brewing time is shown next to the symbol. |
|  | The symbol is displayed when the system lock is switched on. The controls are locked. |
|  | This symbol is displayed while the appliance is being descaled. This symbol can also be found on the water container: fill up to this mark. |
|  | This symbol appears if you call up the Profiles menu. |

Guide to the appliance

| Symbol | Explanation |
|---|---|
|  | This symbol and a fault code will appear if a fault occurs. |
|  | The strength of the Wi-Fi connection is shown under Settings Miele@home Connection status. Symbols represent the connection strength in increments from strong to not connected. |
|  | The symbol appears when MobileStart is activated. |
| | Drinks menu symbols: |
|  | Espresso |
|  | Coffee |
|  | Cappuccino |
|  | Latte macchiato |
|  | Double portion |

Touch display

The sensitive touch display can be scratched by pointed or sharp objects, e.g. pens.
Only touch the display with your fingers.

If your fingers are cold, the touch display may not react.

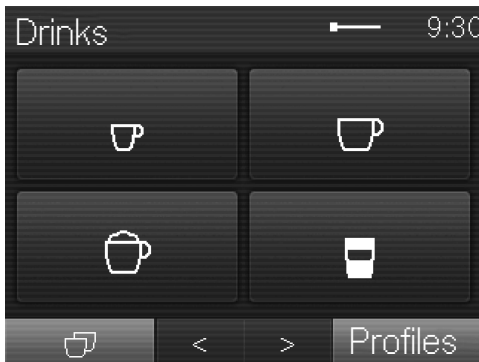

The display is divided into three sections.

The current menu name is displayed in the top left and the time of day in the top right of the display. Depending on the number of items in the menu, a scroll bar may also appear in the middle.

The middle row shows the current menu and options. The most popular drinks are depicted with symbols in the Drinks menu (see "Operating principles – Symbols in the display" for an explanation of the symbols).

You can scroll to the right or left using the < and > arrows at the bottom of the display. Context-dependent functions and menus can be found to the left and right of the arrow sensors.

Operating actions

You can only select options which are highlighted in light grey.

Each time you touch a possible option the relevant field lights up partially or completely **orange**.

Selecting or calling up a menu

- Touch the field you want with your finger.

Scrolling through menus

You can scroll left or right using the < and > arrow sensors.

- Touch the arrow sensor for the direction you want to go.

Exiting a menu ("Back" ↶ sensor)

- Touch the ↶ sensor to return to the previous screen.

Entries made before this which have not been confirmed with *OK* will not be saved.

Operating principles

Entering numbers

Use the numerical keypad to enter numbers, e.g. if you want to set a timer duration. The numerical keypad will appear automatically in the relevant menus.



- Touch the numbers you want.

Once you have entered an accepted value, the *OK* field will light up green.

- Confirm with *OK*.

You can delete one character at a time using the arrow sensor.

Entering letters

Profile names or the names for your own drinks are entered using a keyboard. It is best to select short names (max. 8 characters).

Further letters or symbols can be accessed using the < and > arrow sensors. Numbers can be found by touching the 123 sensor.



- Select the letters or characters you want.
- Touch *Save*.

Your coffee machine is equipped with an integrated Wi-Fi module.

Before installing the coffee machine in its final location, ensure the signal strength of your Wi-Fi network is sufficient.

To use this feature, you will need:

- a Wi-Fi network
- the Miele App
- a Miele user account, which can be created via the Miele App

The Miele App will guide you through the process of connecting your coffee machine to your home Wi-Fi network.

Once your coffee machine is connected to your Wi-Fi network, you can use the Miele App, for example, to carry out the following activities:

- Install software updates
- Call up information on the operating status of your coffee machine
- Change the settings of your coffee machine
- Operate your coffee machine remotely

Connecting your coffee machine to your Wi-Fi network will increase energy consumption, even when the coffee machine is switched off.

Availability of the Wi-Fi connection

The Wi-Fi connection shares a frequency range with other appliances (including microwave ovens and remote control toys). This may result in sporadic or even complete connection failures. Therefore, a constant availability of featured functions cannot be guaranteed.

Miele@home availability

The ability to use the Miele App depends on the availability of the Miele@home service in your country.

The Miele@home service is not available in every country.

For information about availability, please visit www.miele.com.

Miele App

You can download the Miele App from the Apple App Store® or the Google Play Store™ free of charge (only functional in selected countries).



Unpacking and installing

Unpacking the coffee machine

- Unpack the coffee machine.
- Remove any protective foil and stickers from the machine. Exception: Please do not remove any labels (e.g. the data plate) which are visible when you pull out the lower panel.

Useful tip: Please retain the original packaging so that you can pack the appliance securely should you need to transport it in the future.

The drip tray cover can be found in the accessories pack.



- Remove the protective foil from the drip tray cover and place the drip tray cover into the lower panel.

Accessories supplied

The following accessories are included with your coffee machine:

- Milk flask MB-CM-G (capacity 0.5 l)
- Milk siphon
- Cleaning tablets for degreasing the brew unit
- Miele descaling tablets
- Miele descaling cartridge
- Cleaning brush

- Vacuum cleaner attachment for cleaning coffee chute

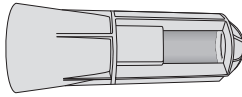

Installing and connecting the coffee machine

⚠ Danger of overheating due to insufficient ventilation.
If the coffee machine is not sufficiently ventilated, the appliance can overheat.

Ensure that there is sufficient ventilation around the coffee machine.

Do not cover the coffee machine with tea towels etc. while it is in use.

If the coffee machine is installed in a niche, heat and moisture will accumulate inside the niche. This can result in damage to the coffee machine and/or furniture unit.

Do not install the appliance in a niche.

Please observe the following installation instructions:

- The location of the machine must be dry and well ventilated.
- The ambient temperature of the room in which the machine is used must be between +16 °C and +38 °C.
- Do not place the coffee machine near a window in direct sunshine or right next to an appliance that gives off heat. These would subject the machine to ambient temperatures outside its permitted operating range.

Unpacking and installing

- The coffee machine must be set up on a level surface. The surface must be water-resistant.
- The appliance door must be opened completely to remove the brew unit.
- Place the coffee machine in the location in which you intend to use it.
- Clean the appliance thoroughly before filling it with mains tap water and coffee beans.
- Insert the plug of the coffee machine into the socket (see "Electrical connection").
- Remove the water container and fill it with fresh, cold tap water. Only fill the water container up to the "max." mark.
- Refit the water container.

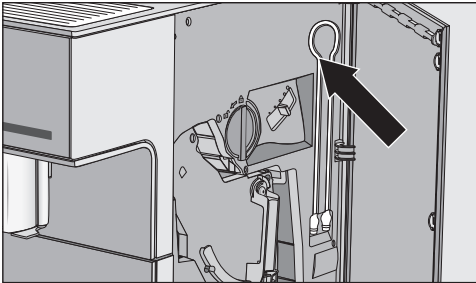

Useful tip: The milk tube can be stored behind the appliance door when not in use.

Before using for the first time

When you connect the machine to the mains power, the following message will appear briefly in the display: Miele.

When you switch on the coffee machine for the first time, Miele appears again briefly in the display.

You will be prompted to enter the following settings:

- Language and country
- Date
- Time of day
- Time of day display
- Automatic descaling
- Water hardness

■ Touch the On/Off ⓘ sensor.

Setting the language

- Select the language.
- Confirm with *OK*.

You might also be asked for your location.

Setting the date

- Enter the current date.
- Confirm with *OK*.

The setting is now saved.

Setting the time of day

- Enter the current time of day.
- Confirm with *OK*.

The setting is now saved.

Fitting the descaling cartridge

Some information about automatic descaling will appear in the display. Further information and instructions can be found in "Automatic descaling" in these operating instructions.

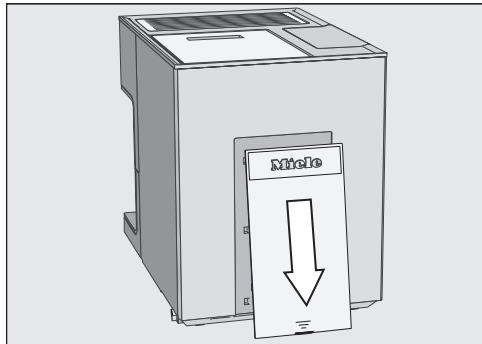

- Remove the cover at the back of the coffee machine.

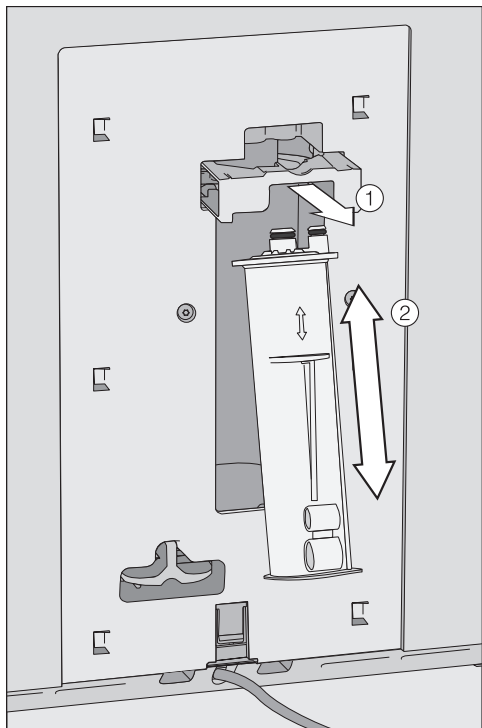

- Pull the cartridge holder ① forwards and insert the descaling cartridge ②. Push the cartridge upwards as far as it will go.
- Push the holder back into position.
- Refit the cover.

Before using for the first time

The next time the coffee machine is switched off, the descaling cartridge will fill with water. You will hear water being pumped into the cartridge at frequent intervals.

When a descaling cartridge is fitted, a message will appear regarding the current start time set for automatic descaling.

- Confirm with *OK*.
- If you want to change the start time, touch *Start time* and select the required time.

You can also change the start time for automatic descaling at a later time.

Setting the water hardness level

Contact your local water supplier to find out your local water hardness range if necessary.

The machine has four programmable levels:

| °dH | mmol/l | ppm (mg/l CaCO ₃) | Set- tings* |
|----------|-----------|----------------------------------|----------------|
| 0 – 8.4 | 0 – 1.5 | 0 – 150 | Soft |
| 8.4 – 14 | 1.5 – 2.5 | 150 – 250 | Medium |
| 14 – 21 | 2.5 – 3.7 | 250 – 375 | Hard |
| > 21 | > 3.7 | > 375 | Very hard |

* The hardness level shown in the display may differ from the hardness level in your area. You **must** follow the values in the chart to set your machine to your local hardness level.

- Select the hardness level.
- Touch *OK* to confirm.

The setting is now saved.

Confirming connectivity of the appliance

To receive software updates and operate the coffee machine via the Miele App, you can connect your coffee machine to your Wi-Fi network.

Miele@home communication enabled household appliance appears in the display.

- Confirm with *OK*.

You can network your coffee machine at any time after initial commissioning. Once the appliance has been networked successfully, any new software that is available will be downloaded automatically via RemoteUpdate the next time the appliance is switched on. In this case, you will be notified that you can install the new software (see “RemoteUpdate”).

The coffee machine is now successfully set up for use. You can now fill the bean system.

Setting up the bean system

After setting up the coffee machine, you will be prompted to set up the bean system. The coffee machine will assist you when first filling and naming the bean containers.

- Touch *Yes*.

If you select *No*, the assistant for setting up the bean system will not be shown again.

Filling the bean containers

Useful tip: Open one bean container lid at a time to prevent mixing of bean types when filling the bean system.

Before using for the first time

- Take one of the lids off.
- Fill the first type of beans in this container.
- Refit the lid.
- Repeat the steps for the other two bean containers.

Useful tip: Make a note of each type of bean if necessary.

After filling the bean containers, you can now name the types of beans.

Naming the types of beans

The three bean containers are shown in the display as follows and are pre-named.

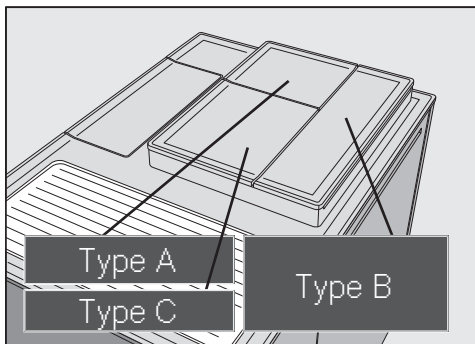

If you rename the bean containers, please note the following:

- Choose concise names (max. 8 characters).
 - If you are using the same type of beans in two or three bean containers at the same time (for instance, because you only use one type of bean), make sure you name them in the same way exactly.
- Enter the name you want for the Type A bean container and then touch **Save**.
 - Now name the other two bean containers.

Continue appears in the display. Now allocate bean types to the coffee drinks.

Allocating bean types

Selected drinks are marked with .

- Select a bean type.
- Now select the drinks that are to be prepared with this type of bean.
- Select the next type of bean and allocate it to other drinks.

Any remaining drinks which have not been selected will be allocated to the third bean type.

You have set up the bean system and you can now prepare drinks.

To ensure that any coffee residues from the factory testing process are removed from the brewing system, please throw away the first two cups of coffee when using the coffee machine for the first time.

Coffee or espresso can be made from whole roasted coffee beans which are freshly ground for each portion. Your coffee machine has a bean system with three bean containers which can be filled with different types of beans or even just one type. You can allocate bean types to individual coffee drinks as you wish. Alternatively, you can create profiles with your own coffee drinks and allocate other bean types to these drinks which are different to the Miele profiles.

Alternatively, you can make coffee drinks with ready ground coffee (see "Making coffee - Making drinks with ready ground coffee").

 Risk of damage to the grinder due to incorrect operation.

The coffee machine will be damaged if the bean container is filled with unsuitable substances such as liquids, ground coffee or coffee beans treated with sugar, caramel or similar. In addition, green (unroasted) coffee beans or mixtures of coffee beans which contain green coffee beans can damage the grinder. Green coffee beans are very hard and still contain residual moisture. These can damage the coffee machine grinder as soon as grinding begins.



Only put roasted coffee beans in the bean container.

Useful tip: You can use a nut or seed grinder to grind green coffee beans. These types of grinder generally have a rotating stainless steel blade. You can then add the ground green coffee **one portion at a time** to the ground coffee chute and make the desired coffee drink (see "Making coffee - Making drinks with ready ground coffee").

If decaffeinated coffee beans are used after dispensing a drink with caffeinated beans, there may still be residues from the caffeinated beans in the grinder or brew chamber. Please be aware that minimal residues of caffeinated beans may be present in the next drink that you make.

Changing bean system settings (Type of beans)

The Drinks menu is shown in the display.

- Touch .
- Touch Settings .
- Touch Type of beans.
- Select a bean type.

You can now change the name or allocation.

Useful tip: If you want to allocate another type of bean to a coffee drink, you can also do this under Change parameters (see "Parameters - Bean type").

Renaming type of beans

The 3 bean containers are shown in the display as follows and are pre-named.

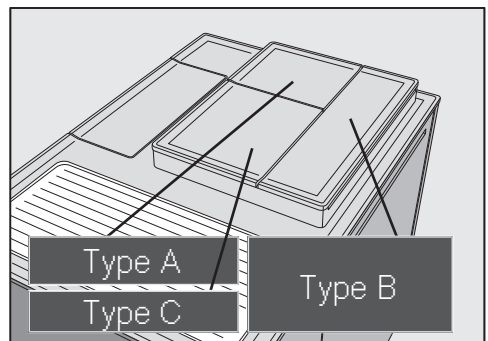

Bean system

If you rename the bean containers, please note the following:

- Choose concise names (max. 8 characters).
- If you are using the same type of beans in two or three bean containers at the same time (for instance, because you only use one type of bean), make sure you name them in the same way exactly.

- Touch **Change name**.

The editor will open in the display.

- Enter the name you want and then touch **Save**.

If you give identically named types of beans different names, you will then need to allocate coffee drinks to the newly named beans.

If you do not allocate a type of bean, you will be asked what type of bean you want to use for the coffee as you make it.

Changing bean type allocation

If you have created additional profiles with coffee drinks to the Miele standard profile, the bean types can be individually allocated to individual drinks in each profile.

- Touch **Change allocation**.

If you have set up one or more profiles and at least one coffee drink, first select the profile.

- Select the profile for which you want to allocate the type of beans.

All coffee drinks will be listed. The already allocated drinks will be indicated by a .

- Change the allocation as required.
- Touch **OK** to confirm.

Useful tip: If you touch **All**, you will highlight all coffee drinks and you can deselect the ones you do not want.

Filling the water container

⚠ Risk to health due to contaminated water.

Bacteria can develop in water which has been sitting in the water container for too long and is a risk to your health.

Change the water in the water container **every day**.

Pour out the water from the water container if a drink has not been prepared for a long time.

If the water container is not inserted correctly (e.g. sits too high or at an angle), water can leak from the outlet valve.

Check whether the surface that the water container sits on is soiled. If necessary, clean the surface that the water container sits on.

⚠ Risk of damage due to incorrect operation.

Unsuitable liquids such as hot or warm water or other liquids can damage the coffee machine.

Carbonated water leaves too much limescale in the coffee machine.

Only use cold, fresh tap water to fill the water container.

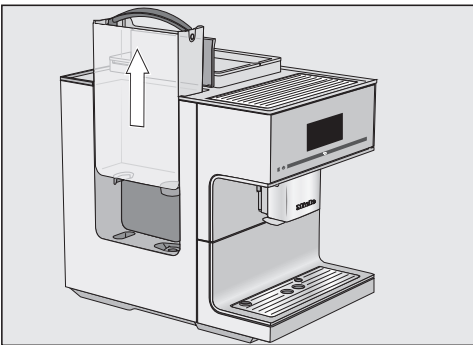

- Open the lid on the left-hand side of the coffee machine.
- Pull the water container up by the handle to remove it.
- Fill the water container with fresh, cold drinking water up to the *max.* mark.
- Refit the water container.
- Close the lid.

Switching on and off

Switching the coffee machine on

- Touch the On/Off ① sensor.

Miele will appear in the display briefly.

The appliance will begin rinsing after the heating-up phase. Hot water will run out of the central spout.

You can now make drinks.

If the coffee machine is already at operating temperature, rinsing will not take place.

While dispensing a drink or during maintenance processes, moisture builds up in the coffee machine. Once a drink has been dispensed or the machine has been switched off, the internal fan will continue to run until the interior is sufficiently dehumidified. You will hear an accompanying noise.

Switching the coffee machine off

- Touch the On/Off ① sensor.

If coffee has been dispensed, the coffee machine will rinse the coffee pipework automatically before switching off.

Preparing for an extended period of inactivity

If the coffee machine is not going to be used for more than 3 days, such as during a holiday, prepare the appliance for this.

- Empty the drip tray, the waste container and the water container.
- Clean all parts thoroughly, including the brew unit and appliance interior.
- Switch off at the socket and unplug the coffee machine's electrical plug to disconnect it from the power supply.

The time of day set will be saved for a maximum of ten days and after that must be reset. Timer settings, profiles and other settings will be kept.

Central spout with cup rim sensor

The central spout with cup rim sensor features automatic adjustment. By means of this spout adjustment, at the beginning of drink preparation the central spout moves down automatically and the cup rim sensor stops it at the optimum height for the cups or glasses being used.

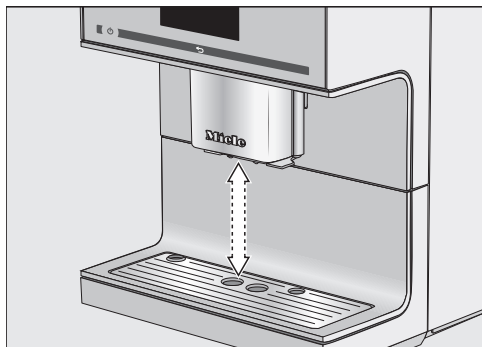

The height of the central spout with cup rim sensor **cannot** be manually adjusted.

Moving the central spout into the maintenance position

You can switch off automatic spout adjustment. The central spout will then remain in the upper position while drinks are being made. When a maintenance programme is being carried out, the central spout will move to the height of the cleaning containers or into a maintenance position.

- To move the central spout into the maintenance position, touch ↵ for 3 seconds.

Useful tip: When the coffee machine is switched off, the central spout is located at a medium height. At this medium height, you can remove and clean the central spout components at any time.

Switching the spout adjustment on and off

The Drinks menu is shown in the display.

- Touch ↵.
- Touch Settings .
- Touch Spout adjustment.
- Select the required option to switch spout adjustment on or off.
- Confirm with *OK*.

The setting is now saved.

Cup heating

⚠ Danger of overheating due to insufficient ventilation.
If the coffee machine is not sufficiently ventilated, the appliance can overheat.
Ensure that there is sufficient ventilation around the coffee machine, e.g. do not cover cups on the cup heating surface with a tea towel.

You can pre-heat cups or glasses on the cup heating surface on the top of the coffee machine.

Cups should always be pre-heated to allow the flavour of the coffee to develop and its temperature to be retained.

When the cup heating surface is activated, the cup rest will be heated continually until the coffee machine is switched off.

Switching cup heating on or off

The **Drinks** menu is shown in the display.

- Touch **↔**.
- Touch **Settings**.
- Touch **Cup heating**.
- Select the required setting to switch cup heating on or off.
- Confirm with **OK**.

The setting is now saved.

The coffee machine is delivered with cup heating switched off.

Pre-heating cups

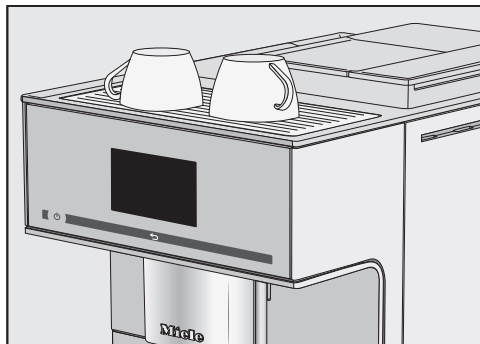

- Arrange the cups or glasses on the cup heating surface on the top of the coffee machine.

Coffee

 Danger of burning and scalding on the dispensing spouts. The liquids and steam dispensed are very hot and can cause scalding. Keep well away from the area underneath the spouts when hot liquids and steam are being dispensed. Do not touch hot components.

Coffee drinks in detail

You can use your coffee machine to prepare the following coffee specialities:

- **Café au lait** is an espresso with slightly hotter milk.
- **Caffè Americano** consists of equal proportions of espresso and hot water. The espresso is made first, then the hot water is dispensed.
- **Caffè latte** consists of coffee and hot milk.
- **Cappuccino** consists of approx. 2/3 milk froth and 1/3 espresso.
- **Cappuccino Italiano** has the same proportions of milk froth and espresso as a cappuccino. The difference is that the espresso is added first and then the milk froth.
- **Espresso** is a strong aromatic coffee with a thick hazelnut brown coloured froth – known as the crema – on top. We recommend using espresso roasted coffee beans to make an espresso.
- **Espresso macchiato** is an espresso with a small amount of milk froth on top. Select a cup which can hold at least 100 ml for this drink.

- **Flat white** is a large cappuccino: lots of espresso with plenty of milk froth.
- **Coffee** differs from espresso by the increased amount of water and the roast of the beans. We recommend using coffee beans with the appropriate roast to make the coffee.
- **Long coffee** is a coffee with considerably more water.
- **Latte macchiato** consists of 1/3 each of hot milk, milk froth and espresso.
- **Long black** is made with hot water and two shots of espresso.

- **Ristretto** is a strong, concentrated espresso. It is prepared with the same amount of coffee as for an espresso but with much less water.

Hot milk or milk froth can also be made separately.

Milk and milk alternatives

Cow's milk or plant-based milk alternatives (e.g. soy milk) containing added sugar can clog up the milk pipework and any other parts that carry milk. Residues from unsuitable liquids may adversely affect correct preparation. Do not use milk with additives.

Animal milk naturally contains bacteria. If using animal milk, make sure that it has been pasteurised, e.g. pasteurised cow's milk.

You can prepare hot milk and milk froth with cow's milk or with plant-based milk alternatives.

Making drinks

After the heating-up phase, the milk will be drawn up into the central spout where it is heated by steam and also frothed for drinks requiring milk froth. Depending on the milk used, the consistency of the milk froth can vary greatly. Not every type of milk is well suited to frothing.

Useful tip: Using cold cow's milk (< 10 °C) with a protein content of at least 3% will produce the perfect milk froth.

You can select milk with a fat content according to preference. With full cream milk (at least 3.5% fat), the milk froth will be slightly creamier than with low-fat milk.

Plant-based milk alternatives - abbreviated as "milk alternatives" in the following - contain other substances than cow's milk, for example. Due to natural settling, thickening can occur in milk alternatives. During the preparation of hot milk or milk froth, such thickening can impede the intake of milk alternatives.

Stir milk alternatives thoroughly directly before drink preparation.

Do not shake milk alternatives. Shaking causes an unwanted formation of froth in the packaging and impairs preparation.

Useful tip: Manually rinse the milk pipework immediately after preparation.

Using the milk flask

Milk is **not** cooled in the milk flask. The milk can spoil if left unchilled in the milk flask for a long period of time (depending on type of milk). Do not leave cow's milk in particular in the milk flask out of the fridge for a long period of time. Please follow the manufacturer's instructions concerning the storage life of the milk being used.

If you have not made any milk drinks for a while, rinse the milk system thoroughly before making the first drink.

- Insert the connecting piece into the lid from above until everything sits flush.
- Connect the stainless steel tube to the inside of the lid. Make sure that the slanted end of the stainless steel tube is pointing downwards.
- If you are using milk alternatives, be sure to stir them thoroughly first. To ensure the best preparation, milk alternatives must be stirred and not shaken.
- Fill the milk flask with milk up to a maximum of 2 cm below the rim.

Useful tip: Use cold milk (< 10 °C) to produce a good quality milk froth.

- Seal the milk flask with the lid.

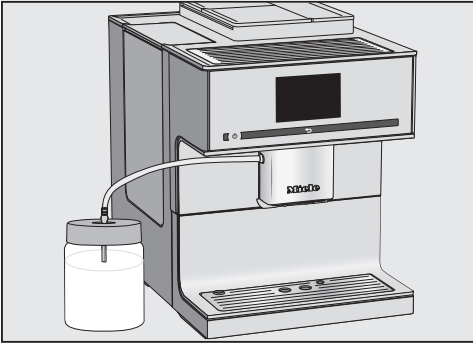

- Place the milk flask next to the coffee machine.
- Connect the milk pipework to the milk flask lid.
- Connect the flask to the coffee machine by attaching the tube to the aperture in the central spout.

Useful tip: It is easier to insert the milk tube in the aperture on the central spout when the central spout is in the maintenance position. Touch the ↶ sensor for 3 seconds.

Using a milk carton with the milk siphon

If you have not made any milk drinks for a while, rinse the milk system thoroughly before making the first drink.

The milk siphon enables you to prepare milk directly from milk cartons and the like. The milk siphon is made up of the connecting piece and a long stainless steel tube.

Useful tip: Use cold milk ($< 10\text{ }^{\circ}\text{C}$) to produce a good quality milk froth.

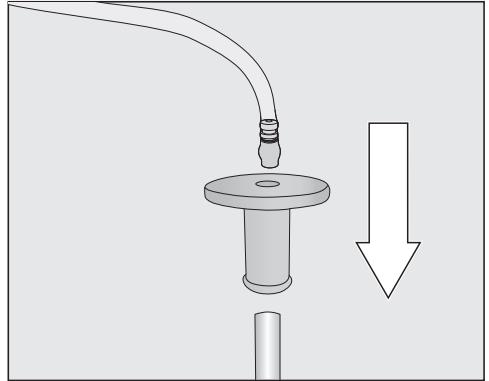

- Connect the connecting piece to the milk siphon.
- Connect the milk tube to the connecting piece.

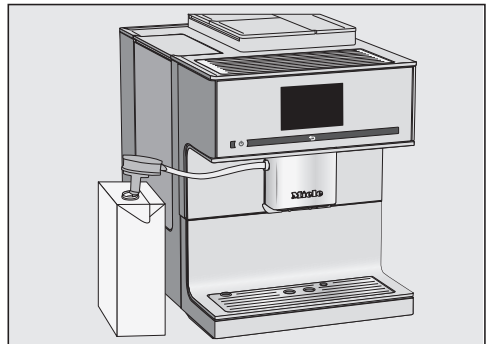

- If you are using milk alternatives, make sure that you stir the milk thoroughly. To ensure the best preparation, the milk must be stirred and not shaken.
- Place the milk carton next to the coffee machine.
- Dip the milk siphon into the milk.
- Connect the milk tube to the aperture in the central spout.

Making drinks

Useful tip: It is easier to insert the milk tube in the aperture on the central spout when the central spout is in the maintenance position. Touch the ↶ sensor for 3 seconds.

Useful tip: Rinse the milk siphon under running water after use.

Making a coffee drink

Further drinks can be displayed and selected using the > arrow sensor.

The Drinks menu is shown in the display.

- If you want to make a coffee with milk, prepare the milk flask or a milk carton with the milk siphon.



- Place a cup or glass under the central spout.
- Touch the symbol or name of the coffee you want to make.

Dispensing will start.

Cancelling preparation

You can finish dispensing individual drink components early, e.g. if the cup is not big enough.

Cancelling individual drink components

- Touch Stop.

Cancelling the entire drink preparation

- Touch Cancel.

DoubleShot

Select the DoubleShot function if you would like a particularly strong and aromatic coffee. In this case, more coffee beans will be ground and brewed halfway through brewing. Due to the reduced extraction time, fewer unwanted aromas and bitter substances are released.

DoubleShot will appear while drinks are being made. DoubleShot can be activated for all coffee drinks except "Ristretto" and "Long black".

Making a DoubleShot of coffee

The Drinks menu is shown in the display.

- Place a cup or glass under the central spout.
- Select the type of coffee you want.

Dispensing will start and the following will appear underneath:



- Touch DoubleShot.

Double the quantity of coffee beans will be ground and brewed.

Making two portions ☞

With "Two portions" ☞ you can dispense two portions of a drink at the same time.



- Place one cup under each of the coffee spouts.
- Touch ☐.
- Select a drink.

Two portions of the drink will be dispensed.

Coffee pot: making several cups of coffee one after the other

You can make several cups of coffee one after the other automatically with the Coffee pot function (max. 1 litre), e.g. to fill a coffee pot. Up to eight cups can be made in this way.

The Drinks menu is shown in the display.

You can use the Coffee pot function twice in a row. After this, the coffee machine needs to cool down for one hour in order to avoid it being damaged.

- Place a sufficiently large container under the central spout.
- Select Coffee pot.
- Select the number of cups you want (3 to 8).
- Follow the instructions in the display.

Each portion of coffee will be ground, brewed and dispensed individually. The display will inform you about the progress.

Cancelling Coffee pot

You can interrupt preparation at any time.

- Touch Cancel.

Making drinks with ready ground coffee

You can make coffee using ready ground coffee. This allows you to prepare a decaffeinated coffee, for example, even if the bean container is filled with regular coffee beans.

To do this, fill the ground coffee drawer with ground coffee. The coffee machine will use all the ground coffee which has been added to the chute to make the next coffee.

Only **one** portion of coffee or espresso can be made at a time.

Adding ready ground coffee

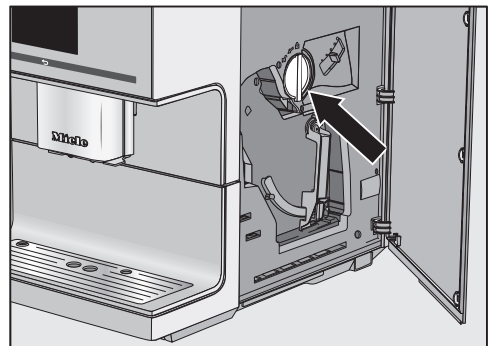

The coffee scoop is integrated into the ground coffee drawer.

- Open the appliance door.
- Turn the handle (see arrow) to the left to remove the ground coffee drawer.

Making drinks

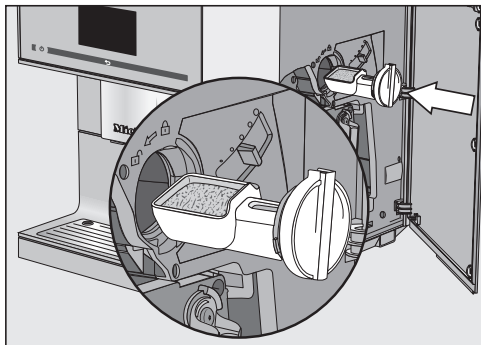

- Fill the coffee scoop with ready ground coffee. Push the ground coffee drawer horizontally into the ground coffee chute.

In order to not overfill the brew unit, place a maximum of **2** level scoops of coffee in the ground coffee chute.

- Turn the handle clockwise to fill the brew unit with the ground coffee and to close the ground coffee chute.
- Close the appliance door.

Use ground coffee? appears in the display.

Making drinks with ready ground coffee

- Touch Yes.

You can now select which type of drink you would like to make with the ground coffee.

- Place a cup or glass under the central spout.
- Select a drink.

The coffee machine will prepare the desired drink.

If you select No, the ground coffee will be disposed of in the waste container without being brewed. The appliance rinses.

Tea

This machine is not intended for commercial or scientific purposes. Temperatures given are approximate and can vary according to ambient conditions.

To make tea, you can select from the following options:

- **Green tea** approx. 80 °C
- **Herbal tea** approx. 90 °C
- **Fruit tea** approx. 90 °C
- **Black tea** approx. 90 °C

The type of tea determines the preset temperature.

The respective dispensing temperatures are recommended by Miele for making black tea, green tea, herbal or fruit tea.

Follow the instructions for making tea on the tea packaging.

The taste of the tea will be affected by the type of water used. Water should be as soft as possible to allow the aroma to develop.

Whether you use loose tea leaves, blended tea or tea bags depends on your own personal preferences.

The amount of tea and the brewing time will vary depending on the type of tea. Always follow the recommendations of the manufacturer on the packaging or of the supplier. The amount of hot water used can be adjusted depending on the type of tea and the size of the cup (see "Portion size").

Useful tip: Store the tea in a cool, dark place in tightly sealed containers. It is best to buy smaller amounts to prevent loss of aroma.

TeaTimer

You can use the TeaTimer to start a minute minder when making tea. A brewing time of 2 minutes is preset as standard. You can adjust the preset brewing time according to your preferences (between 1:00 and 23:59 minutes).

The TeaTimer can be started twice consecutively.

If you have started a TeaTimer, while the brewing time is counting down you can continue to use the coffee machine as normal. An audible tone will sound after the brewing time has elapsed.

If you have switched off audible tones, you will not be reminded when the brewing time has finished.

Switching the TeaTimer on and off

The Settings  menu is shown in the display.

- Select Timer.
- Select TeaTimer.
 - On: the TeaTimer is displayed while the hot water is being prepared. The TeaTimer can be started after preparation.
 - Off: the TeaTimer is not displayed.
- Select the desired setting.
- Confirm with *OK*.

Making tea

 Danger of burning and scalding on the hot water spout!
The liquids and steam dispensed are very hot and can cause scalding.
Keep well away from the area underneath the hot water spout when hot liquids and steam are being dispensed.
Do not touch hot components.

The hot water spout is located to the right of the central spout.

Use the arrow sensor  to display and select the types of tea. Different types of tea can be found in the drinks menu after Milk froth.

The Drinks menu is shown in the display.

- Pour loose tea into a tea filter or similar or take a tea bag out of the packet.
- Place the tea filter or the tea bag in the tea cup.



- Place the cup under the hot water spout.
- Select the type of tea from the display.

Hot water will be dispensed into the cup.

Making drinks

You can now start the minute minder for the brewing time if the TeaTimer is switched on.

Starting the TeaTimer

TeaTimer appears in the bottom left of the display.

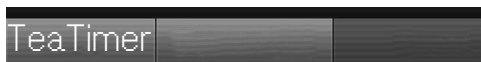

- Touch TeaTimer.

TeaTimer will be selected. After dispensing, the editor will open with a suggested time.

- Change the brewing time if necessary.
- Confirm with *OK*.

An audible tone will sound after the brewing time has elapsed.

- Now remove the tea leaves or the tea bag.

Cancelling tea preparation

- Touch Stop or Cancel.

Teapot: making several cups of tea one after the other

You can make several cups of tea one after the other automatically with the Teapot function (max. 1 litre), e.g. to fill a tea pot. Up to eight cups can be made in this way.

The Drinks menu is shown in the display.

- Place the tea or teabag in a suitably sized teapot.
- Place the teapot under the hot water spout.
- Select Teapot.
- Select the type of tea you want.
- Select the number of cups you want (3 to 8).
- Follow the instructions in the display.

The teapot will be filled. The display will inform you about the progress.

You can interrupt preparation at any time:

- Touch Cancel.

Preparing hot water

 Danger of burning and scalding on the hot water spout!

The liquids and steam dispensed are very hot and can cause scalding. Keep well away from the area underneath the spouts when hot liquids and steam are being dispensed.

Do not touch hot components.

The hot water has a temperature of approx. 90 °C when dispensed.

The amount of hot water used can be adjusted depending on the size of the cup (see “Portion size”).

The Drinks menu is shown in the display.

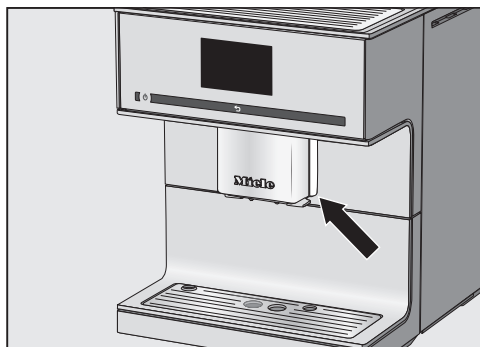

- Place a suitable cup or glass underneath the hot water spout.
- Select Hot water.

Dispensing will start.

Cancelling preparation

- Touch Stop or Cancel.

You can individually adjust the following parameters for each drink:

- Amount of coffee
- Brewing temperature
- Pre-brewing
- Bean type

Changing drink parameters

The Drinks menu is shown in the display.

- Select Process.
- Touch Change drink.
- Select a drink.

Now you can adjust the portion size (see "Portion size") or set the drink parameters.

- Touch Drink parameters.
- Select Amount of coffee, Brew temperature, Pre-brewing or Type of beans.
- Select the desired setting.
- Confirm with *OK*.

The overview of drink parameters will appear in the display.

- Touch *OK* again to save your changed settings.

Amount of coffee

The coffee machine can grind and brew 7.5–12.5 g of coffee beans per cup. The greater the quantity, the stronger the coffee.

The quantity of coffee is **too low** if the espresso or coffee lacks body.

To brew more ground coffee, increase the the amount of coffee.

The quantity of coffee is **too high** if the espresso or coffee tastes bitter.

To brew less ground coffee, decrease the amount of coffee.

Brewing temperature for coffee drinks

The brewing temperature must be adapted to the beans you are using and how they are roasted. It also varies depending on whether you are making espresso or coffee.

Some bean types are sensitive to high brewing temperatures, resulting in an impaired taste. If your coffee tastes bitter, the brewing temperature you have selected might be too high.

Espresso is usually brewed at higher temperatures.

Pre-brewing ground coffee

When the pre-brewing function is switched on, the ground coffee is first moistened with a little hot water. The ground coffee swells a little. The remaining amount of water is then pressed through the moistened coffee grounds shortly after. If your coffee tastes too bland and you want to add some spice and richness, try the "Pre-brewing" function. Depending on the type of coffee used, pre-brewing can intensify the taste.

You can set a short or long duration for pre-brewing or turn the "Pre-brewing" function off completely.

Useful tip: We particularly recommend using the "Pre-brewing" function to make coffee.

Bean type

You can display which type of bean is saved for the coffee drink or change the allocation.

Grinder setting

The grinder setting determines the contact time between the ground coffee and the water, known as the extraction time. Only when the ideal grinder setting is selected, can the machine dispense a perfect cup of coffee with a fine, hazelnut-brown crema.

Identifying the correct grinder setting

There are various ways to tell whether the coffee grinder is set correctly.

The coffee has been **too coarsely** ground if:

- the espresso or coffee flows into the cup very quickly,
- the espresso or coffee tastes sour,
- the crema is very pale and uneven.

The coffee has been **too finely** ground if:

- the espresso or coffee flows into the cup very slowly,
- the espresso or coffee tastes too bitter,
- the crema is dark brown.

Adjusting the grinder setting

If the grinder setting is adjusted by more than one setting at a time, the grinder can be damaged.

Only adjust the grinder one setting at a time.

Dispense a drink after each adjustment in order to grind a portion of coffee beans. Adjust the grinder setting one setting at a time again.

The slide control for adjusting the grinder setting is located on the top right behind the appliance door.

- Open the appliance door.

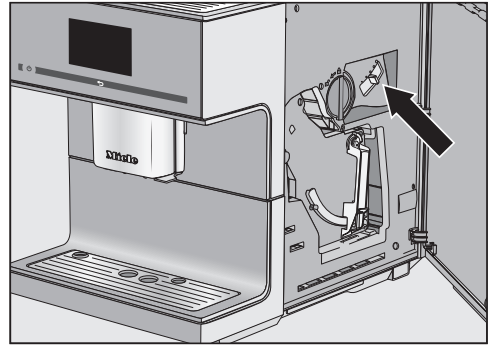

- Push the slide control a maximum of one setting to the left (for finer grinding) or to the right (for coarser grinding).

The grinder setting you select will be used for all types of beans and coffee drinks.

- Close the appliance door.
- Make one cup of coffee.

Now you can adjust the grinder setting again.

The grinder wears out a little naturally over time with use. Set the grinder to a finer setting if necessary.

The flavour of the coffee produced depends not only on the type of coffee, but also on the amount of water used. You can programme the amount of water for all coffee drinks and hot water to suit the size of your cups and the type of coffee you are using. This does not alter the amount of coffee used.

For coffee drinks with milk you can also set the amount of milk or milk froth to suit your personal taste. Additionally, you can set the portion sizes for hot milk and milk froth alone.

The changed portion size is always saved in the current profile. The name of the current profile is shown in the top left of the display.

If the water container becomes empty during the preparation of a drink, the programming of the portion size will be cancelled. The portion size will **not** be saved.

Changing the portion size

The **Drinks** menu is shown in the display.

- Place the cup you want under the central spout or hot water spout.
- Touch **Process**.
- Touch **Change drink**.
- Select a drink.
- Touch **Portion size**.

If you have selected a drink with milk or tea, portion programming will start immediately. **Portion size** does not need to be opened separately.

The drink will be made and **Save** will appear in the display as soon as the minimum dispensing amount is reached.

- When the cup is filled up to the level you want, confirm with **Save**.

If the maximum amount is reached, preparation stops and the maximum possible amount is saved.

If you want to change the portion size for coffee drinks made with milk or hot water, the ingredients (components) which make up the drink will be saved one after the other while the drink is being made.

The programmed combination of ingredients and portion sizes will now be dispensed every time that particular drink is selected.

Resetting drink settings

You can reset portion sizes and parameters individually or for all drinks back to their factory default setting. The Drinks menu is shown in the display.

- Touch Process.

Resetting a drink

- Touch Reset drink.
- Select a drink.

Reset drink to default settings? appears in the display.

- Touch Yes to confirm.

Resetting all drinks

- Touch Reset all drinks.

Reset all drinks to default settings? appears in the display.

- Touch Yes to confirm.

In addition to the Miele drinks menu (Miele profile), you can create up to 10 individual profiles to cater for different tastes and preferences.

The name of the current profile is shown in the top left of the display.

Creating a profile

The Drinks menu is shown in the display.

- Touch Profiles.
- Touch Create profile.

The editor will open in the display.

- Enter the name you want (max. 8 characters).
- Touch Save to confirm.

The profile is created. You can now create drinks (see "Profiles: creating and editing drinks").

Calling up a profile

The Drinks menu is shown in the display.

- Touch Profiles.
- Select the profile you want.

You now have the following options:

- Preparing User profile drinks
- Creating a drink
- Changing parameters for the individual drinks in the profile or deleting a drink

Editing a profile

Once you have created at least one profile, you can edit this profile.

The Drinks menu is shown in the display.

- Touch Profiles.
- Touch Process.

You can now edit the following profile settings:

- Change profile
- Change name
- Delete profile

Changing a profile

You can set up the coffee machine so that it changes back to the Miele drinks menu automatically after each drink is dispensed or so that it retains the most recently selected profile.

The Drinks menu is shown in the display.

- Touch Profiles.
- Touch Process.
- Touch Change profile.

You now have the following options:

- **Manual:** The selected profile remains active until you select another profile.
 - **After each use:** The machine will change back to the Miele drinks menu automatically after a drink is dispensed.
 - **When switched on:** Each time the machine is switched on it will automatically select the Miele drinks menu regardless of which profile was set before the machine was last switched off.
- Select the desired option.
 - Confirm with *OK*.

Changing a name

The Drinks menu is shown in the display.

- Touch Profiles.
- Touch Process.
- Touch Change name.
- Select the profile you want.

User profiles

- Change the name as required:
- Touch *Save* to confirm.

The changed profile name is saved.

Deleting profile

The *Drinks* menu is shown in the display.

- Touch *Profiles*.
- Touch *Process*.
- Touch *Delete profile*.
- Tap the profile you want.
- Confirm with *OK*.

The profile is deleted.

Creating a drink in a profile

You can create new drinks based on existing drinks.

- Open the profile you want.
- Touch *Create drink*.
- Now select a drink.
- Change the portion size or drink parameters to create the drink you want.

Drink preparation will begin and you can save the portions of each component as desired.

- Enter a name for the new drink (maximum 8 characters).
- Touch *Save* to confirm.

The new drink will appear in the first position in the current profile.

The last created drink will appear in the first position in the current profile. The order of the drinks in a profile cannot be changed.

Changing a drink: Changing the portion size(s), drink parameters and names

The portion quantities and parameters for coffee and milk drinks, hot water and tea can be adjusted in each profile.

The desired profile with the newly created drinks will appear in the display.

- Open the profile you want.
- Touch *Process drink*.
- Touch *Change drink*.
- Select a drink.

You can now change the portion size(s), drink parameters or the names.

Deleting a drink from a profile

The desired profile with drinks will appear in the display.

- Open the profile you want.
- Touch *Process drink*.
- Touch *Delete drink*.
- Select a drink.
- Confirm with *OK*.

The entry will be deleted.

Making a drink from a profile

The *Drinks* menu is shown in the display.

- Touch *Profiles*.
- Select the profile you want.

The name of the selected profile is shown in the top left of the display. You can now make the drink you want.

- Place a suitable cup or glass underneath the central spout.
- Select a drink.

Dispensing will start.

In Expert mode you can change the portion size while the drink is being made. The setting will **not** be saved and will only apply for the current drink.

Expert mode is not available if you have selected DoubleShot or two portions ☞.

Switching Expert mode on and off

The Drinks menu is shown in the display.

- Touch ↩.
- Touch Settings ⚙.
- Touch Expert mode.
- To switch Expert mode either on or off, select the option you want.
- Touch OK to confirm.

If Expert mode has been switched on, you can now change the portion size while the drink is being dispensed.

Expert mode: changing the amount of coffee and portion size

The Drinks menu is shown in the display.

The portion size can only be changed when the respective ingredient is being processed while the drink is being made.

Changing portion size

- Select a drink.

Dispensing will start. You can adjust the portion size while it is being dispensed, e.g. individually change the amount of hot milk, milk froth and espresso for Latte macchiato.

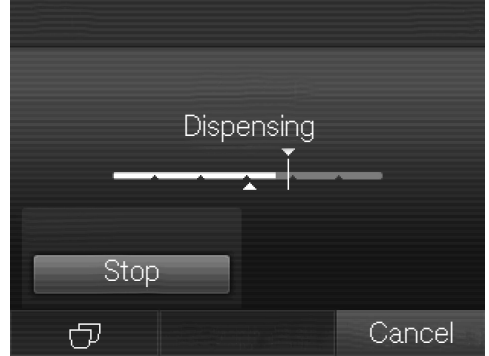

- Touch the segments and adjust the indicator (small triangle) as you wish.

Settings

You can use the Settings menu to customise the coffee machine to suit your individual requirements.

Some settings which can be found in the Settings menu are described in their separate sections in the operating instructions.

Opening the "Settings" menu

The Drinks menu is shown in the display.

- Touch ↩.
- Touch Settings .

You can now check or change the settings.

The settings which are currently selected will have a coloured frame around them.

Tapping ↩ takes you back to the previous menu level.

Changing and saving settings

The Settings  menu is shown in the display.

- Select the option you want to change.
- Select the desired setting.
- Confirm with *OK*.

The setting is now saved.

Language

You can select a language and location variant for all display texts.

Useful tip: If you select the wrong language by mistake, you can find the "Language" option again via the  symbol.

Time of day

You can set the display for when the time of day appears after switching off the appliance, the clock format and the time.

Time of day display

You can choose one of the following options:

- On: the time of day and date are always visible in the display when the appliance is switched off.
- Off: the time of day and date are not visible in the display when the appliance is switched off.
- Night dimming: the time of day and date are displayed from 5:00 am to 11:00 pm.

The time of day display can only be switched on when the coffee machine is networked.

When the time of day display is switched on, the energy consumption of the coffee machine increases. A message appears in the display to inform you of this.

Clock format

You can select:

- 24-hour display (24 h)
- 12-hour display (12 h (am/pm))

Setting

Set the hours and then the minutes.

If the coffee machine has been connected to a Wi-Fi network and is signed into the Miele App, the time will be synchronised based on the location setting in the Miele App.

Timer

There are two timers with the following timer functions:

The coffee machine

- switches on at a particular time, e.g. in the morning for breakfast (Switch on at).
- switches off at a particular time (Switch off at).
- switches off after a particular length of time if none of the sensors has been touched or a drink has not been made (Switch off after; available with Timer 1 only).

You can allocate the timer functions to individual days of the week.

For Switch on at and Switch off at, the timer must be activated and at least one day of the week allocated.

Selecting a timer

You can select:

- Timer 1: Switch on at, Switch off at, Switch off after
- Timer 2: Switch on at, Switch off at

Switch on at

The coffee machine will **not** switch on at the required time if you have activated the system lock. The timer settings are deactivated.

If the coffee machine has switched itself on automatically **three times** via the Switch on at timer function and no drinks have been dispensed, the machine will not switch itself on again automatically. This prevents the coffee machine from switching itself on unnecessarily, for example, whilst you are away on holiday. The programmed times will, however,

remain in memory and will be reactivated after manually switching the machine on again.

Switch off at

In the event of a longer absence the programmed times will remain in memory and will be reactivated after manually switching the machine on again (see "Switch on at").

Switch off after

The Switch off after timer function is only available in Timer 1.

If none of the sensors have been touched or no drink has been made, the coffee machine will switch itself off after 20 minutes to save energy.

You can change this pre-setting to a time of between 15 minutes and 9 hours.

Allocating days of the week

The selected day of the week will be marked by .

- Select the required day of the week.
- When all required days of the week are marked, confirm with *OK*.

Activating and deactivating the timer

For the time display, you have selected On or Night dimming:

If the timer for Switch on at has been activated, the symbol ☺ and the desired switch-on time appear in the display 23:59 hours ahead of time.

When the system lock is activated, the Switch on at timer function cannot be selected.

Select the timer function you want to use. The selected timer function will have a next to it.

Settings

Eco mode

Eco mode is an energy-saving mode. The system heats up only once drink preparation has started.

Eco mode is activated by default.

Lighting

The following options are available:

- The machine is switched on: set the brightness.
- The machine is switched off: set the brightness and set the time the lighting should switch off.

When the coffee machine is switched on, it remains lit up for a certain length of time after the last action. This time cannot be adjusted.

Water hardness

If a descaling cartridge is **not** fitted and you descale the coffee machine using descaling tablets, the machine should be set to the local water hardness. A prompt to descale the machine will then appear in the display at the correct time.

Programme the coffee machine to the water hardness level of your area so that it functions correctly and does not get damaged.

Contact your local water supplier to find out your local water hardness range if necessary.

If you are using bottled drinking water, e.g. mineral water, select settings according to the calcium content. The calcium content is given on the label of the bottle in mg/l Ca²⁺ or ppm (mg Ca²⁺/l).

Do not use carbonated water.

Useful tip: If your water hardness is >21 °dH (3.8 mmol/l), we recommend instead to use bottled drinking water (< 150 mg/l Ca²⁺). This will mean your coffee machine will need to be descaled less often and there will be less impact on the environment because less descaling agent will be used.

The machine is programmed ex-works to hardness level 3.

The machine has four programmable levels:

| °dH | mmol/l | ppm (mg/l CaCO ₃) | Set-tings* |
|----------|-----------|-------------------------------|-------------|
| 0 – 8.4 | 0 – 1.5 | 0 – 150 | Soft 1 |
| 8.4 – 14 | 1.5 – 2.5 | 150 – 250 | Medium 2 |
| 14 – 21 | 2.5 – 3.8 | 250 – 375 | Hard 3 |
| > 21 | > 3.8 | > 375 | Very hard 4 |

* The hardness level shown in the display may differ from the hardness level in your area. You **must** follow the values in the chart to set your machine to your local hardness level.

Info (display information)

In the Info option you can choose to display the number of prepared portions for each type of drink.

You can also see how many portions can be dispensed before the brew unit needs to be degreased (No. of drinks until).

To return to the previous display, touch .



System lock

You can lock the coffee machine to prevent it being used without your knowledge, for example by children.

Activating and deactivating the system lock

When the system lock is activated, the timer settings for *Switch on at* are deactivated. The coffee system will **not** switch on at the time set.

Temporarily deactivating the system lock

If you touch the On/Off switch ,  will appear.

- Touch  as long as a relevant instruction appears in the display.

As soon as you switch the coffee machine off, it will be locked again.

Miele@home

The following points may appear under Miele@home:

- Set up: This option only appears if the coffee machine has not previously been connected to a Wi-Fi network or the Network configuration has been reset.
- Deactivate*/Activate*: The settings for the Wi-Fi network are retained, but the network is switched on or off.
- Connection status*: Information about the Wi-Fi connection is displayed. The symbols indicate the strength of the connection.
- Set up again*: The settings for the current Wi-Fi network will be reset. The Wi-Fi connection will be set up again.

* This option appears if Miele@home has been set up and the coffee machine has been connected to your Wi-fi network.

Display brightness

You can set the display brightness using the bar chart.

Volume

You can set the volume of buzzer and keypad tones using a segment bar.

Service

Evaporating the coffee machine

The coffee machine should be evaporated before it is stored for a long period of time or transported any distance (see “Transporting the machine”).

Demo mode

Do not activate this function for domestic use.

The appliance can be presented in Miele Experience Centres or retail stores with the Demo mode function. The lighting will come on but drinks cannot be dispensed and other actions cannot be carried out.

Factory default settings

You can reset the settings back to the ones which were set when the coffee machine was delivered - the factory default settings.

Please refer to the “Overview of available settings” chart for the factory settings.

Settings

Appliance settings

The following will **not** be reset:

- The number of drinks dispensed and the appliance status (No. of portions until appliance needs descaling, ... brew unit needs degreasing)
- Language
- Time and date
- Profiles and their associated drinks (the allocation of bean types to drinks is reset)

The Descaling timer is reset to 04:00.

Network configuration

The settings for the Wi-Fi network will be reset.

The network configuration should be reset whenever the coffee machine is being disposed of or sold, or if a used coffee machine is being put into operation. This is the only way to ensure that all personal data has been removed and, in the case of the latter, the previous owner will no longer be able to access the coffee machine.

Your coffee machine is Wi-Fi enabled and can be operated via the Miele App using a mobile device, e.g. smartphone or tablet.

Please ensure you adhere to the warning and safety instructions in these operating instructions even when you are operating the coffee machine via the Miele App.

Energy consumption increases when the coffee machine is connected to a Wi-Fi network. This applies even when the coffee machine is switched off.

Setting up the network (Miele@home)

Networking is deactivated as standard.

- Make sure that the signal of your Wi-Fi network is sufficiently strong in the place where you want to set up your coffee machine.

The Settings  menu is shown in the display.

- Touch Miele@home.
- Touch Set up.
- Select the connection method you wish to use:
 - via the Miele App
 - via WPS
- Follow the instructions provided in the coffee machine display and in the Miele App.

Connection successfully established appears in the display.

Setting up the network again

If your Wi-Fi network has changed, you can set up Miele@home for your coffee machine again.

The Settings  menu is shown in the display.

- Touch Miele@home.
- Touch Set up again.
- Follow the instructions in "Setting up the network (Miele@home)".

Remote control



Remote control is only visible when the coffee machine is connected to a Wi-Fi network.

You can change the coffee machine settings, for example, in the Miele App when remote control is switched on. To start making a drink via the App, MobileStart must be additionally activated.

Remote control is activated ex-works.

Switching remote control on or off

The Drinks menu is shown in the display.

- Touch .
- Touch Settings .
- Touch Remote control.
- Select the required option to switch remote control on or off.

Network

Preparing MobileStart

 Danger of burning and scalding on the dispensing spouts.

If liquids or steam are dispensed while the machine is unsupervised, persons may burn themselves if they place body parts under the central spout or touch hot components.

Ensure that no one, especially children, can be harmed if the machine is operated without supervision.

Milk is **not** cooled in the milk flask or in a milk carton.

Milk may spoil if it is left in the milk flask or carton for an extended period without being cooled (depending on the type of milk).

In particular, do not leave cow's milk in the milk flask or carton for an extended period without cooling it.

Please follow the manufacturer's instructions concerning the storage life of the milk being used.

With MobileStart, you can start making a drink, for example, via the Miele App.



You will only be able to use MobileStart if:

- Miele@home has been set up for your coffee machine and
- the Remote control and MobileStart functions have been switched on.
- Make sure that the coffee machine is ready to use – for example, check that the water container and bean container are sufficiently filled.
- Place a sufficiently large, empty cup or glass under the central spout.

Switching MobileStart on and off

If you want to switch on MobileStart, the Remote control function must be switched on.

The Drinks menu is shown in the display.

- Touch .
- Touch Settings .
- Touch MobileStart.
- Select the relevant option to switch MobileStart on or off.

You can now start making a drink via the App.

If you are making a drink via the App, you will be notified when the drink is being dispensed via audible and visual signals. These signals cannot be changed or switched off.

While MobileStart is switched on, the  symbol lights up and the time of day is always shown in the display of the coffee machine when it is switched off.

Automatic descaling and activation rinsing will not start if MobileStart is switched on. The pipework is not pre-warmed when the machine is switched on either, meaning that the cup under the central spout is not filled with rinse water.

If the coffee machine is being operated manually, it cannot be operated via the App. Operation on the appliance takes precedence.

As soon as you have made a drink via the App or opened the appliance door, MobileStart is automatically switched off.

RemoteUpdate

The RemoteUpdate menu option is only displayed and can only be selected if the requirements for using Miele@home have been met.

The RemoteUpdate function is used for updating the software in your coffee machine. If an update is available for your coffee machine, this will be downloaded by the machine automatically. Updates will not be installed automatically. They must be initiated manually.

If you do not install an update, you can continue to use your coffee machine in the usual way. However, Miele recommends installing updates.

Switching on/Switching off

RemoteUpdate is switched on as standard. Available updates will be downloaded automatically but will only be installed if you initiate the installation manually.

Switch off RemoteUpdate if you do not wish any updates to be downloaded automatically.

Running a RemoteUpdate

Information about the content and scope of an update is provided in the Miele App.

A message will appear in your coffee machine display if a software update is available.

You can install the update immediately or postpone this until later. When the coffee machine is switched on again, you will be reminded about the update.

Deactivate RemoteUpdate if you do not want to install the update.

The update may take several minutes to install.

Please note the following information about the RemoteUpdate function:

- You will only receive a message when an update is available.
- Once an update has been installed, it cannot be undone.
- Do not switch off the coffee machine during an update. Otherwise, the update will be aborted and will not be installed.
- Some software updates can only be carried out by Miele Customer Service.

Cleaning and care



Risk to health due to inadequate cleaning.

Heat and moisture inside the coffee machine can cause coffee residues to become mouldy and/or milk residues to go off and pose a risk to health.

Carefully clean the coffee machine regularly.

Cleaning intervals - Quick guide

| Recommended frequency | What do I have to clean/maintain? |
|--|---|
| Daily (at the end of the day) | Water container |
| | Waste container |
| | Drip tray and drip tray cover |
| | Milk flask |
| | Milk siphon |
| | Cup rim sensor |
| Once a week (more often if heavily soiled) | Central spout |
| | Brew unit |
| | Area underneath the brew unit and the drip tray |
| | Casing |
| Once a month | Bean container |
| | Ground coffee chute and ground coffee drawer |
| | Water container filter (or as required) |
| When prompted | Milk tube |
| | Degrease the brew unit (using the cleaning tablets) |
| | Descale the machine if prompted to do so in the display |

Cleaning by hand or in the dishwasher

The brew unit is **not** dishwasher-safe. Clean the brew unit by hand only under warm running water. **Do not use washing-up liquid or any other cleaning agent.**

The following must be cleaned **by hand only**:

- Central spout stainless steel cover
- Cup sensor
- Brew unit
- Coffee bean container lid
- Lower panel

 Risk of damage as a result of excessively high dishwasher temperatures.

Components may be rendered unusable (e.g. deformed) if washed in a dishwasher at a temperature of more than 55 °C.

For dishwasher-safe parts, the maximum temperature of the dishwashing programme selected must not exceed 55 °C.

Contact with natural dyes such as those found in carrots, tomatoes and ketchup may discolour the plastic parts in the dishwasher. This discolouration does not affect the stability of the parts.

The following components are **dishwasher safe**:

- Drip tray and lid
- Drip tray cover
- Waste container

- Water container
- Central spout (without stainless steel cover)
- Ground coffee drawer
- Milk flask with lid
- Milk siphon

 Danger of burning and scalding on hot components or by hot liquids. Components can become very hot during operation. Touching hot components can cause burning. The liquids and steam dispensed are very hot and can cause scalding. Keep well away from the area underneath the spouts when hot liquids and steam are being dispensed.

Always allow the coffee machine to cool down before cleaning it.

Please be aware that water in the drip tray can also be very hot.

 Risk of damage due to moisture ingress.

The steam from a steam cleaner could reach electrical components and cause a short circuit.

Do not use a steam cleaner to clean the coffee machine.

It is important to clean the machine regularly, as the used coffee grounds will soon go mouldy. Milk residues can go off and can block the milk pipework.

Cleaning and care

Unsuitable cleaning agents

Contact with unsuitable cleaning agents can alter or discolour the external surfaces. All surfaces of this appliance are susceptible to scratching. Scratches on glass surfaces could cause a breakage in certain circumstances.

Remove any residual cleaning agent immediately. To protect the machine and surrounding surfaces from damage, make sure you remove any spillages or splashes of descaling agent immediately.

To avoid damaging the surfaces of your appliance, do not use:

- cleaning agents containing soda, alkalines, ammonia, acids or chlorides
- solvent-based cleaning agents
- cleaning agents containing descaling agents (unsuitable for cleaning the housing)
- stainless steel cleaning agents
- dishwasher cleaners (unsuitable for cleaning the housing)
- glass cleaning agents
- cleaning agents for ceramic cooktops
- oven cleaner
- abrasive cleaning agents, e.g. powder cleaners and cream cleaners
- hard, abrasive sponges, e.g. pot scourers, brushes or sponges which have been previously used with abrasive cleaning agents
- dirt eraser sponges
- sharp metal scrapers
- steel wool or stainless steel wire scourers

Cleaning the drip tray and waste container

 Danger of burning and scalding on hot components or by hot liquids. Components can become very hot during operation. Touching hot components can cause burning. The liquids and steam dispensed are very hot and can cause scalding.

If the pipework has just been rinsed, wait a while before removing the drip tray as the water used for rinsing will still run out of the coffee spouts.

Please be aware that water in the drip tray can also be very hot.

Do not touch hot components.

To avoid unpleasant smells and mildew, clean the drip tray and waste container **every day**.

A prompt will appear in the coffee machine display when the drip tray and/or the waste container is full and must be emptied. Empty the drip tray **and** the waste container.

The waste container is located in the drip tray.

Remove and empty the drip tray and the waste container while the coffee machine is switched on. Otherwise the message Empty the drip tray and the waste container will appear in the display even though the drip tray and/or the waste container are not filled to the maximum level.

- Pull the drip tray carefully out of the machine.

Water from rinsing also collects in the waste container.

- Empty the drip tray **and** the waste container.

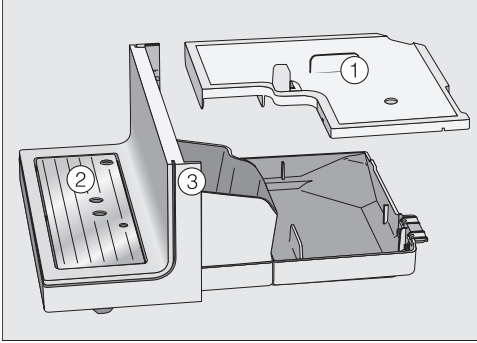

- Remove the lid ①, the drip tray cover ② and the lower panel ③.

Clean the lower panel by hand only using warm water, a little washing up liquid and a soft cloth. All other parts are dishwasher-safe.

- Clean all parts by hand.

Useful tip: To give the drip tray, waste container, lid and drip tray cover an extra thorough clean, clean them in the dishwasher from time to time.

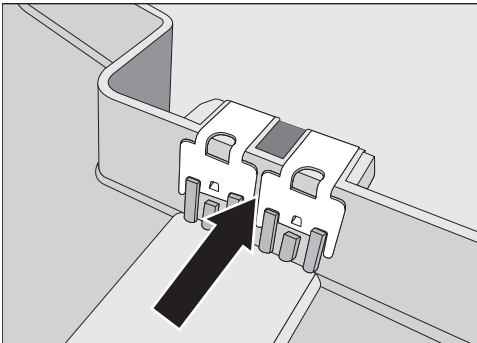

- Clean the contacts (metal discs) and the space between them carefully.
- Dry all parts thoroughly.

The contacts will not be able to detect that the drip tray is full if they are damp or dirty. Check the contacts and the area around them once a week.

- Clean the inside of the machine underneath the drip tray.
- Replace the waste container, the lid and the lower panel **before** pushing the drip tray back into the coffee machine. Make sure that the drip tray is pushed right into the coffee machine as far as it will go.

Cleaning the drip tray cover

- Remove the drip tray cover.
- Clean the drip tray cover by hand using warm water, a little washing up liquid, and a soft cloth.
- Dry the drip tray cover.

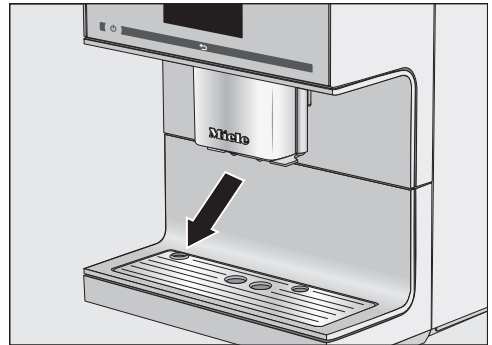

- Refit the drip tray cover. Make sure that the drip tray cover is correctly fitted (see picture).

Useful tip: To clean the drip tray cover particularly thoroughly, clean it occasionally in the dishwasher.

Cleaning and care

Cleaning the water container

Clean the water container by hand every day.

- Remove the water container.
- Clean the water container by hand with warm water and a little washing-up liquid.
- After cleaning, dry the water container.

Useful tip: To clean the water container particularly thoroughly, clean it occasionally in the dishwasher.

- Carefully clean and dry the surface the water container sits on, particularly the recesses.
- Refit the water container.

Make sure that the valve, the underside of the water container and the surface the water container sits on are clean. Otherwise, the water container will not sit correctly.

Please note that the automatic descaling programme will only work if the water container has been filled (at least 500 ml water) and correctly fitted in the machine.

Removing and cleaning the water container filter

Clean the water container filter once a month.

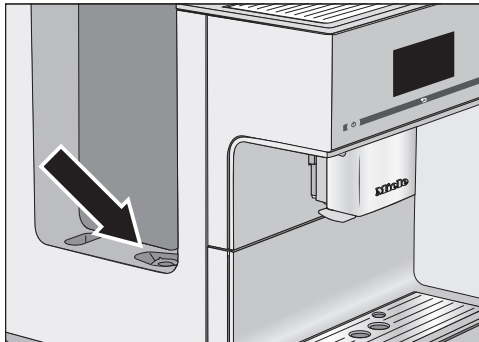

The water container filter is located underneath the water container.

- Remove the water container.

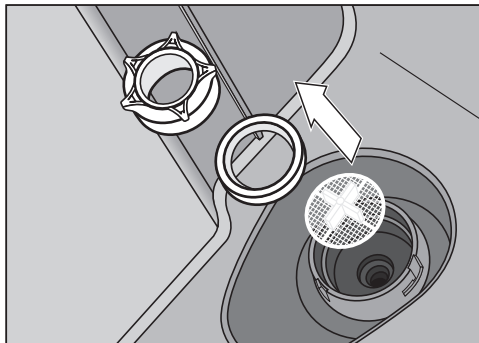

- Unscrew the cap.
- Remove the seal and the filter.
- Clean the parts by hand.
- Rinse all parts carefully under running water.
- Then replace the filter (with the cross facing upwards) and then the seal.

The opening of the seal should face downwards.

- Screw the cap back on tightly.
- Refit the water container.

Cleaning the central spout

Clean all parts of the central spout with integrated Cappuccinatore at least **once a week**.

The Drinks menu is shown in the display.

Removing and dismantling the central spout

If the central spout is in the uppermost position, it cannot be dismantled. The central spout must be moved into the maintenance position to do this.

- Touch ↵ for 3 seconds.

The central spout will move into the maintenance position.

Useful tip: If the coffee machine is switched off, the central spout components can be removed and cleaned at any time.

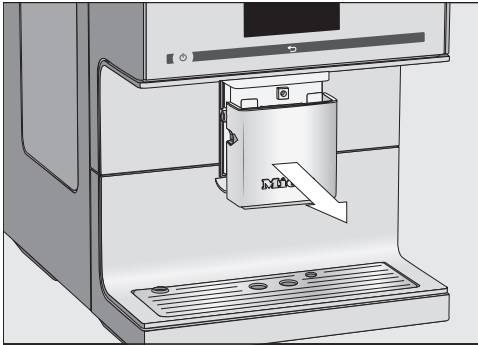

- Carefully pull the stainless steel cover off.

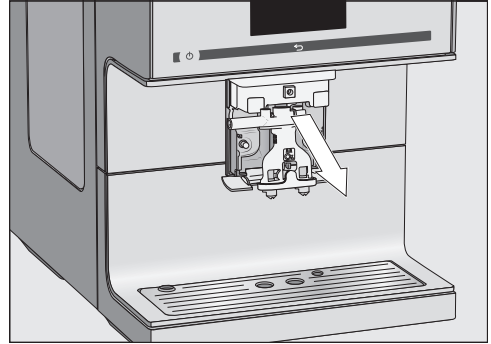

- Pull the dispensing unit off towards you.

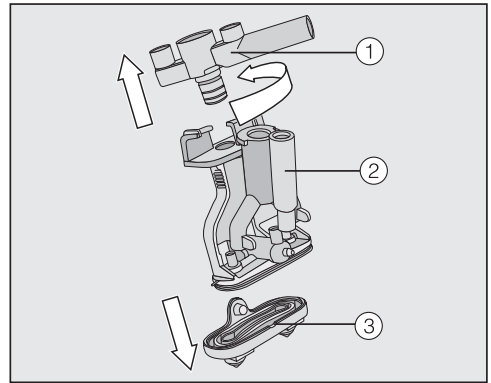

- Twist off the upper section ① with the holder for the milk tube. Pull the component off. Then pull the Y-shaped piece ② off. Remove the dispensing spouts ③.

Cleaning the central spout

Clean the central spout's stainless steel cover **by hand only**, using warm water and a little washing-up liquid.

- Clean all parts thoroughly by hand.

Cleaning and care

Useful tip: With the exception of the stainless steel cover, all parts of the central spout should be cleaned in the dishwasher from time to time to give them a thorough clean. This will remove coffee deposits and milk residues effectively.

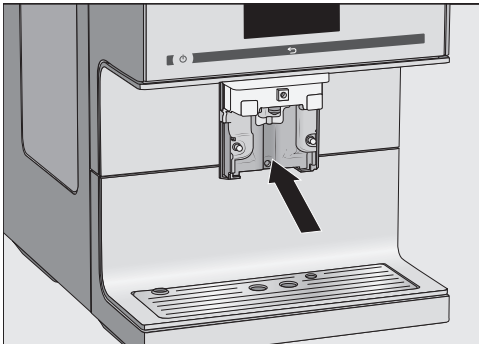

- Clean the surfaces of the central spout with a damp cloth.
- Clean any blockages in the milk pipework under running water with the cleaning brush supplied: to do this, insert the brush in the pipework. Move it back and forth until all milk residue has been removed.

Fitting the central spout

The dispensing unit is easier to reassemble if the individual parts are dampened with water beforehand.

- Reassemble the dispensing unit. Push the spouts ③ firmly back onto the dispensing unit.

Make sure that all parts are tightly connected to one another.

- Refit the dispensing unit into the central spout.
- Refit the stainless steel cover.
- Confirm with *OK*.

Cleaning the steam jet

Clean the steam jet once a month.

- To move the central spout into the maintenance position, touch ↵ for 3 seconds.
- Carefully pull the stainless steel cover off.
- Pull the dispensing unit off towards you.

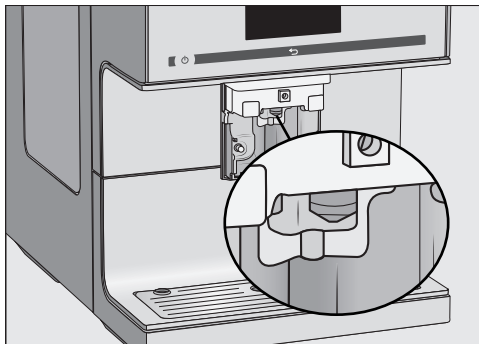

Push the cleaning brush a max. of 1 cm into the steam jet.

- Clean the steam jet with the cleaning brush.
- Refit the dispensing unit into the central spout.
- Refit the stainless steel cover.

Cleaning the cup rim sensor

Clean the cup rim sensor every day.

The cup rim sensor is located underneath the central spout.

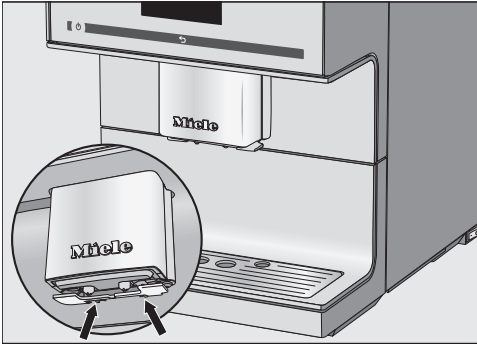

- Push the two locking catches together (see arrows).
The cup rim sensor will be released.
- Clean the cup rim sensor by hand with warm water and a little washing-up liquid.
- Dry the cup rim sensor.

To refit:

- Push the cup rim sensor from underneath into the holder on the central spout.

Cleaning the milk siphon

Clean the milk siphon every day.

- Rinse the milk siphon under running water.
- Remove the connecting piece from the stainless steel tube.
- Clean the parts by hand under running water with a little washing-up liquid.
- If necessary, soak the parts overnight in water and a little washing-up liquid.
- Rinse the parts under running water afterwards.
- Dry the parts.

Useful tip: To give the individual parts an extra thorough clean, clean them in the dishwasher from time to time.

Cleaning the milk flask

Clean the milk flask every day.

- Unscrew the lid from the milk flask.
- Remove the stainless steel tube.

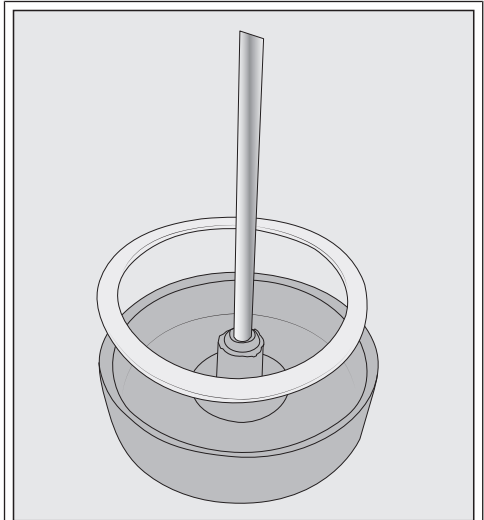

If necessary, you can remove the connecting piece and sealing ring from the milk flask lid. Once you have removed the stainless steel tube, the connecting piece is easy to push out from the inside of the lid.

- Clean all parts of the milk flask by hand using hot water and a little washing-up liquid.
- Dry all parts afterwards.

Useful tip: To give the individual parts of the milk flask an extra thorough clean, clean them in the dishwasher from time to time.

Cleaning and care

Cleaning the milk pipework manually or using the maintenance programme

⚠ Risk to health due to inadequate cleaning.

Milk naturally contains bacteria. Heat and moisture inside the coffee machine can cause these bacteria to multiply, e.g. milk residues can go off and pose a risk to health.

Clean all components in which milk is transported on a regular basis.

The milk pipework must be cleaned at least once a week. A message in the display will prompt you when this needs to be done.

■ Confirm with *OK*.

When you confirm the message *Clean the milk pipework* with *OK*, the internal counter for the cleaning interval will be reset. You will **not** be reminded again.

There are two options for cleaning the milk pipework:

- You can remove and dismantle the central spout with its integrated cappuccinatore and either wash it in the dishwasher or by hand with warm water and a little washing-up liquid (see "Cleaning the central spout with integrated cappuccinatore").
- Or you can clean the milk pipework using the *Clean the milk pipework* maintenance programme together with the Miele Cleaning agent for milk pipework (see "Cleaning the milk pipework").

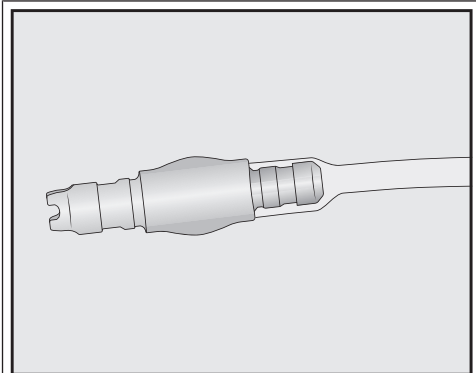

If you have released the connecting piece from the milk pipework: when reassembling, ensure that the smaller, thinner end of the connecting piece is pushed into the hose.

Useful tip: In addition to your weekly cleaning routine we recommend carrying out the alternative cleaning procedure once a month. For example, if you manually clean the machine once a week, then you should run the maintenance programme once a month. This combination will ensure that the milk pipework is cleaned optimally.

Cleaning the bean system

⚠ Danger of injury on the moving grinder!

If you reach into the grinder or objects such as a spoon are left in the grinder and a grinding process is unintentionally started, you could be injured.

Switch off the machine and disconnect it from the power supply before cleaning the bean system.

Coffee beans contain oils which can deposit on the walls of the bean containers and hinder the flow of the beans. Therefore, clean the bean containers regularly with a soft cloth. If required, you can clean the lids of the bean containers **by hand** with warm water and a little washing-up liquid. Dry the lids thoroughly before refitting them on the bean containers.

- Remove the lid of each bean container.
- Remove any coffee beans.

Useful tip: Use a vacuum cleaner to remove any coffee residues from the bean containers.

- Clean the bean containers with a dry, soft cloth.

You cannot remove the finger protection grille.

- Refit the lids.

The bean containers can now be refilled individually.

Useful tip: Open one lid at a time to prevent mixing of bean types when filling the bean system.

Cleaning the ground coffee drawer

Clean the ground coffee drawer and chute for ground coffee regularly, e.g. when you degrease the brew unit.

- Open the appliance door.

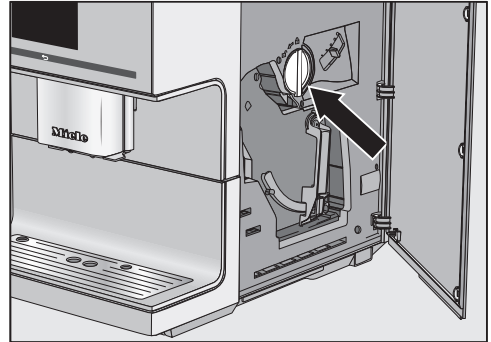

- Turn the handle (see arrow) to the left to remove the ground coffee drawer.
- Clean the ground coffee drawer by hand using warm water and a little washing-up liquid.
- Dry the ground coffee drawer.

Useful tip: To give the ground coffee drawer an extra thorough clean, clean it in the dishwasher from time to time.

- Remove any ground coffee residues from the ground coffee chute with a soft, dry cloth.
- Refit the ground coffee drawer.
- Turn the handle to the right to close the ground coffee chute.
- Close the appliance door.

Vacuuming out the ground coffee chute

In order to remove coffee residues properly from the grinder channel, you should vacuum out the ground coffee chute once a year with the vacuum cleaner attachment (supplied).

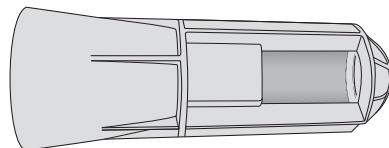

- Open the appliance door.

Cleaning and care

- Remove the ground coffee drawer.

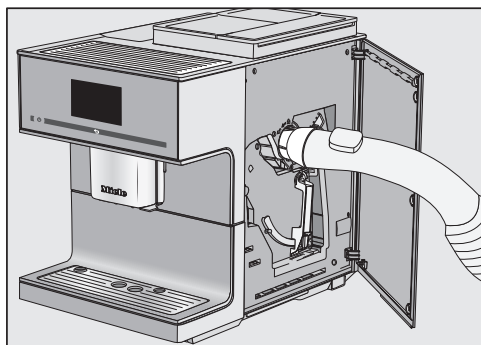

- Insert the attachment and use the suction tube of your vacuum cleaner to vacuum out the ground coffee chute.
- Remove the vacuum cleaner attachment.
- Refit the ground coffee drawer.
- Close the appliance door.

Cleaning the housing

If soiling is allowed to stay on for a long time or there is contact with unsuitable cleaning agents, surfaces can alter or discolour.

Remove any soiling immediately.

To protect the machine and surrounding surfaces from damage, make sure you wipe up any spillages or splashes of descaling agent immediately.

- Switch the coffee machine off.
- Clean the appliance front with a clean soft sponge and a solution of warm water and washing-up liquid.
- Dry all surfaces with a soft cloth.

Useful tip: You can also clean the appliance front with the Miele all purpose microfibre cloth.

Maintenance programmes

The coffee machine has the following maintenance programmes:

- Rinse the machine
- Rinse the milk pipework
- Clean the milk pipework
- Degrease the brew unit
- Descale the machine

Carry out the relevant maintenance programme when the prompt to do so appears in the display. You can also start maintenance programmes at any time so that the coffee machine does not prompt mandatory cleaning at an inconvenient time.

Please note that each maintenance programme must be carried through to the end and cannot be cancelled.

Opening the “Maintenance” menu

The **Drinks** menu is shown in the display.

- Touch .
- Touch **Maintenance**.

You can now select a maintenance programme.

Rinsing the appliance

If coffee has been dispensed, the coffee machine will rinse the coffee pipework automatically before switching off. This removes any coffee residues.

You can also rinse the pipework manually.

The **Drinks** menu is shown in the display.

- Touch .
- Touch **Maintenance**.
- Touch **Rinse the machine**.

You may also be prompted to insert the end of the milk pipework into the drip tray.

Rinsing the milk pipework

Milk residues can block the milk pipework. The milk pipework should therefore be rinsed regularly. If a drink has been made using milk, the prompt to insert the end of the milk tube into the drip tray will appear at the latest when you switch the machine off.

You can also rinse the milk pipework manually.

The **Drinks** menu is shown in the display.

Useful tip: Place a suitable cup or glass underneath the central spout.

- Touch ↶.
- Touch Maintenance.
- Touch Rinse the milk pipework.

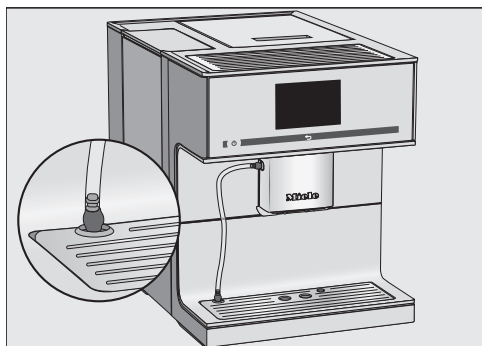

- Place the end of the milk pipework into the aperture in the drip tray cover.
- Confirm with **OK**.

The milk pipework will now be rinsed.

Cleaning the milk pipework

You need 1 stick of cleaning agent for milk pipework to clean it.

For optimal cleaning results, we recommend the Miele cleaning agent for milk pipework. The powder cleaning agent for milk pipework has been specially developed for use with Miele coffee machines and prevents subsequent damage.

It is available to order from the Miele online shop or directly from Miele (see the end of this booklet for contact details).

The **Clean the milk pipework** maintenance programme lasts for approx. 10 minutes.

The **Drinks** menu is shown in the display.

- Touch ↶.

The cleaning process cannot be cancelled. It must be completed through to the end.

- Touch Maintenance.
 - Touch Clean the milk pipework.
- The process will start.
- Follow the instructions in the display.

Insert milk pipe in cleaning agent appears in the display.

Making a cleaning solution:

- Dissolve the powder cleaning agent in a container with 200 ml of lukewarm water. Stir the solution with a spoon until it has fully dissolved.

Cleaning and care

Carrying out the cleaning process:



- Place the container next to the machine and hang the milk pipework in the solution. Make sure it is placed sufficiently far into the cleaning solution.
- Confirm with *OK*.
- Follow the further instructions given in the display.

The cleaning process is finished at the end of the rinsing cycle.

Degreasing the brew unit

Depending on the natural oil content of the coffee used, the brew unit can become blocked quite quickly. The brew unit must be degreased regularly in order to ensure aromatic coffee and trouble-free operation of the coffee machine.

We recommend using Miele cleaning tablets to clean the brew unit. These have been specially developed for use with Miele coffee machines and prevent subsequent damage.

Miele cleaning tablets are available to order from the Miele online shop or directly from Miele (see the end of this booklet for contact details).

Message in display

After 200 drinks have been dispensed, *Degrease the brew unit* will appear in the display.

- Confirm with *OK*.

The message will appear again at regular intervals. Once the maximum possible number of portions has been reached, the coffee machine will lock out.

You can switch the coffee machine off if you do not want to carry out the maintenance programme at this point in time. You will only be able to make coffee drinks again once the brew unit has been degreased.

Degreasing the brew unit when prompted to do so

Degrease the brew unit appears in the display and no drinks can be made.

You need 1 cleaning tablet for the maintenance programme.

The maintenance programme for degreasing the brew unit lasts for approx. 10 minutes.

The maintenance programme cannot be cancelled. It must be completed through to the end.

- Confirm with *OK*.

The maintenance programme will start.

- Follow the instructions in the display.

Cleaning the brew unit and the interior

To ensure good tasting coffee and to prevent the formation of microbes in the appliance, clean the brew unit and interior once a week.

You need 1 cleaning tablet to clean the brew unit.

Cleaning and care

 Risk to health due to inadequate cleaning.

Damp coffee residues in the interior of the machine can go mouldy and pose a risk to health.

Remove coffee residues regularly and clean the interior of the machine.

- Open the appliance door.

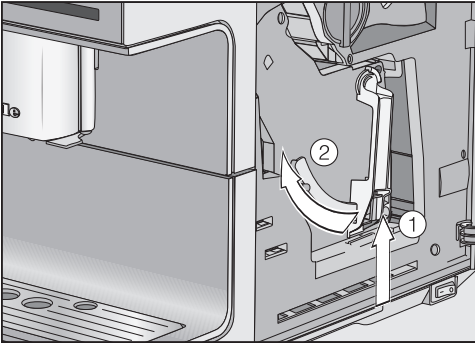

- Press and hold the button on the end of the brew unit handle ① and, whilst doing so, turn the handle to the left ②.

When you have removed the brew unit, **do not** change the position of the handle on the brew unit. Otherwise the brew unit cannot be refitted.

- Carefully pull the brew unit out of the coffee machine.

The moving parts of the brew unit are lubricated. Cleaning agents will damage the brew unit.

Clean the brew unit by hand only under warm running water. **Do not use washing-up liquid or any other cleaning agent.**

- Clean the brew unit **by hand under warm running water** without using washing-up liquid or any other cleaning agent.

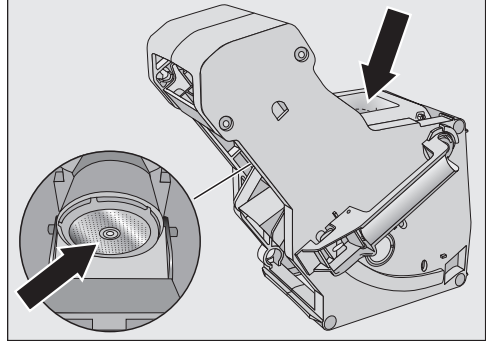

- Wipe any coffee residues off the two filters (see arrows).
- Dry the funnel to prevent ground coffee sticking to it the next time a coffee is prepared.

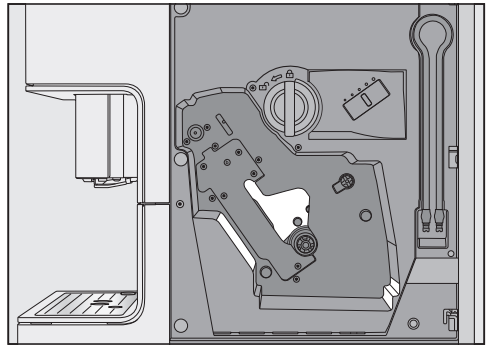

- Clean the interior of the coffee machine. Make sure that the areas highlighted (in white) in the illustration are cleaned especially well.

Useful tip: Use a vacuum cleaner to remove dry ground coffee residues.

Fit brew unit with tablet inside appears in the display.

Cleaning and care

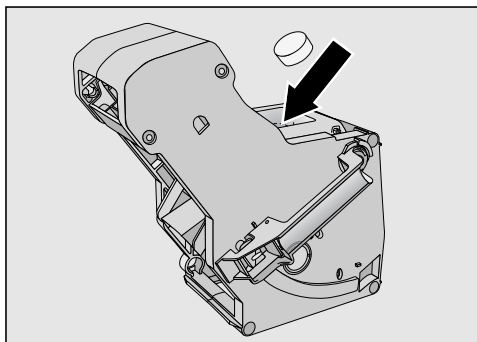

- Drop a cleaning tablet into the top of the brew unit (arrow).
- Push the brew unit with cleaning tablet back into the coffee machine, making sure it goes in straight.

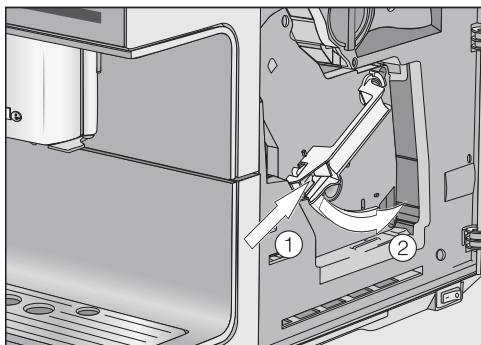

- Press the button on the end of the brew unit handle ① and, whilst doing so, turn the handle to the right ②.

The handle engages audibly.

- Close the appliance door.
- Follow the further instructions given in the display.

The cleaning process is finished at the end of the rinsing cycle. You can now prepare drinks again.

Descaling the appliance

Risk of damage from spilt descaling solution.

Sensitive surfaces and/or natural floors can suffer damage.

Wipe up any spillages of descaling agent immediately.

Limescale builds up in the coffee machine through use. How often the appliance needs to be descaled will depend on the water hardness level in your area. Limescale must be removed regularly.

Depending on how you use your machine and the water hardness level in your area, occasionally you will need to descale your machine manually in addition to automatic descaling.

If a descaling cartridge is **not** fitted, an **empty** cartridge is fitted or an **expired** cartridge is fitted, the machine needs to be descaled regularly using the **Descal** the machine maintenance programme.

The appliance will guide you through the descaling process. Various messages will appear in the display, e.g. you will be prompted to empty the drip tray or fill the water container.

You need **1** descaling tablet for the descaling process. The process takes approx. 12 minutes.

The coffee machine prompts you when it needs to be descaled. Number of drinks until the machine must be descaled: **50** will appear in the display. The remaining number of drinks that can be made before descaling will appear in the display after each drink.

- Confirm with **OK**.

When the number of remaining portions reaches 0, the coffee machine will lock out.

Descal the machine appears in the display.

You can switch the coffee machine off if you do not want to run the descaling programme at this point in time.

However, you will not be able to make drinks again until you have descaled the coffee machine.

Descaling after prompt appears in the display

Descal the machine appears in the display.

Descaling cannot be cancelled once it has started. It must be completed through to the end.

- Confirm with *OK*.

The process will start.

- Follow the instructions in the display.

When Fill the water container to the \mathcal{S} symbol with descaling agent and lukewarm water and place it in the machine appears in the display, proceed as follows.

For optimum descaling results, we recommend using the Miele descaling tablets.

The descaling tablets have been specially developed for Miele coffee machines.

Other descaling agents, which contain other acids besides citric acid and/or other undesirable substances, such as chlorides, may cause damage to the product. Moreover, the descaling result required cannot be guaranteed if the descaling solution was not of the appropriate concentration.

Miele descaling tablets are available to order from the Miele online shop or directly from Miele (see the end of this booklet for contact details).

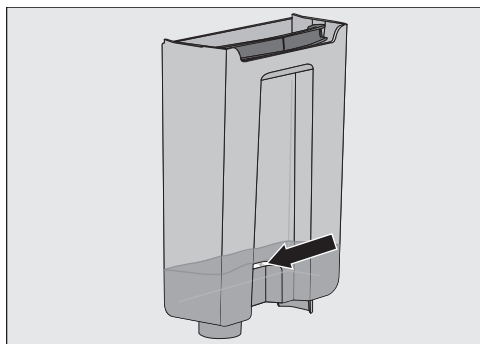

- Fill the water container to the descaling symbol \mathcal{S} with lukewarm water.
- Add **1** descaling tablet to the water container.

Follow the instructions for the mixing ratio carefully. It is important to fill the water container with the correct amount of water. Otherwise the descaling process will be cancelled prematurely.

Carrying out descaling

- Refit the water container.
- Follow the further instructions given in the display.

When Rinse the water container and fill it to the \mathcal{S} symbol with fresh tap water appears in the display:

- Remove the water container and rinse it thoroughly with clean water. Ensure that **no** descaling solution residue remains in the water container.
- Fill the water container to the descaling symbol \mathcal{S} with fresh tap water.

Cleaning and care

The descaling process is complete at the end of the rinsing process. You can now prepare drinks again.

Risk of damage from spilt descaling solution.

Sensitive surfaces and/or natural floors can suffer damage.

Wipe up any spillages of descaling agent.

When handling a cartridge which has already been filled with water, ensure that the descaling solution does not come into contact with sensitive surfaces.

To ensure the longevity of components and a machine consistently free of limescale, the coffee machine needs to be manually descaled from time to time. The intervals are determined by your usage patterns and the water hardness level of your area. If you make a lot of coffees with milk, for example, you will need to descale the coffee machine more frequently with the descaling tablets.

The coffee machine has an automatic maintenance programme for descaling the machine. For automatic descaling, a Miele descaling cartridge is fitted at the back of the coffee machine. The coffee machine will automatically determine the days on which to carry out automatic descaling based on the usage pattern. Automatic descaling takes approx. 30 minutes, including the activation time.

You can set the time for automatic descaling to start using the [Descaling timer](#).

Water is mixed with the descaling agent to create a solution for automatic descaling. This descaling solution is then pumped through the pipework of the coffee machine. After the activation time, the solution is rinsed out of the pipework and the machine can then be used as normal for making drinks.

During automatic descaling you will hear pumping and rinsing noises at frequent intervals even though the appliance is switched off and the display is dark.

If you do not make any drinks, automatic descaling will not be started.

Please note before and during automatic descaling:

The coffee machine must be ready to use and the following conditions must be met:

- A descaling cartridge which is ready to use is fitted.
- The coffee machine is connected to the electricity supply. The coffee machine must **not** be disconnected from the electricity supply during automatic descaling.
- The drip tray, brew unit and central spout are fitted.
- The water container is inserted and is filled with water at least up to the  descaling mark (at least 500 ml water).
- Carry out the instructions which appear in the display before switching off, e.g. Empty the drip tray.
- The milk pipework is inserted into the holders in the drip tray and on the central spout.
- The coffee machine is switched off.

Automatic descaling

The Miele descaling cartridge

Only use the Miele descaling cartridge for the automatic descaling programme.

Please note that the Miele descaling cartridge has a storage life of approx. one year after it has been placed in the machine and filled with water for the first time. Critical for the one-year storage life is the date on which the descaling cartridge was fitted and filled with water.

Do not use a descaling cartridge which has already been used in another Miele coffee machine. Your coffee machine will have no information about the fill level of this cartridge. The descaling effect may be insufficient and damage your coffee machine.

Do not fill the descaling cartridge with other fluids or substances.

The descaling agent comes in the form of tablets in the descaling cartridge. The cartridge is filled with water when it is placed in the machine. The tablets gradually dissolve over time.

The Miele descaling cartridge will last for 7 to 12 months of automatic descaling, depending on how often the coffee machine is used.

A prompt will appear in the display shortly before the cartridge is depleted, reminding you that it needs to be replaced. Confirm the message with *OK*. After this first message, six more descaling programmes are possible.

The descaling cartridge is available to order from the Miele online shop or directly from Miele (see back cover for contact details).

If a descaling cartridge is **not** fitted, an **empty** cartridge is fitted or an **expired** cartridge is fitted, the machine needs to be descaled using the *Descale the machine* maintenance programme. To do this, the appropriate descaling agent is required (see "Cleaning and care - Descaling the appliance").

The descaling cartridge can remain fitted even if the machine is not used for a long time. Remove the cartridge before transporting the coffee machine. However, please note the following:

- Once filled with water, the descaling cartridge has a maximum shelf life of three weeks outside of the machine.
- It should be transported with care and upright. Avoid shaking it. Shaking or turning upside down reduces the storage life and damages the cartridge.
- The cartridge should be stored upright, in a dark place and at room temperature (16 – 38 °C).

Fitting the descaling cartridge

Risk of damage from spilt descaling solution.

Sensitive surfaces and/or natural floors can suffer damage.

When handling a cartridge which has already been filled with water, ensure that the descaling solution does not come into contact with sensitive surfaces.

Automatic descaling

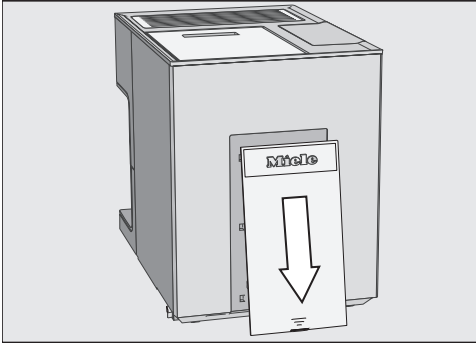

- Refit the cover.
- Follow the instructions in the display.

The next time the coffee machine is switched off, the new descaling cartridge will fill with water when the machine is rinsed. You will hear water being pumped into the cartridge at frequent intervals.

Removing the descaling cartridge

Risk of damage from spilt descaling solution.

Sensitive surfaces and/or natural floors can suffer damage.

When handling a cartridge which has already been filled with water, ensure that the descaling solution does not come into contact with sensitive surfaces.

The coffee machine is switched on. Only then will the appliance detect the descaling cartridge.

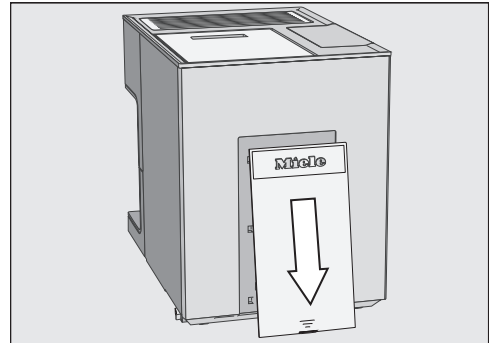

- Slide the cover at the back of the coffee machine downwards.

- Slide the cover at the back of the coffee machine downwards.

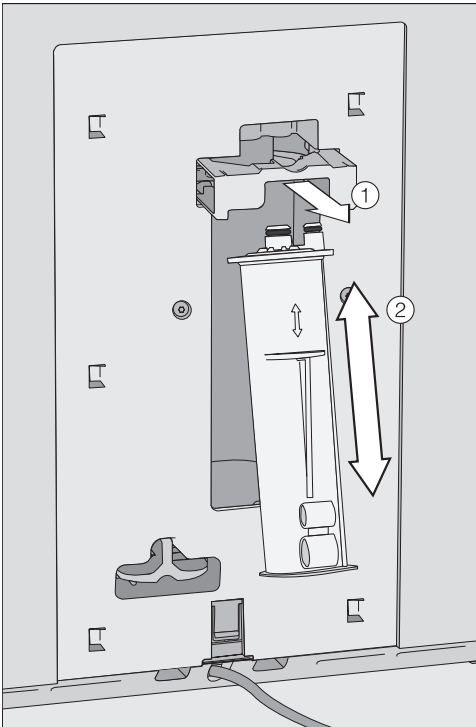

- Pull the cartridge holder ① forwards.
- Insert the cartridge ② and push it upwards as far as it will go.
- Push the cartridge holder back into position.

Automatic descaling

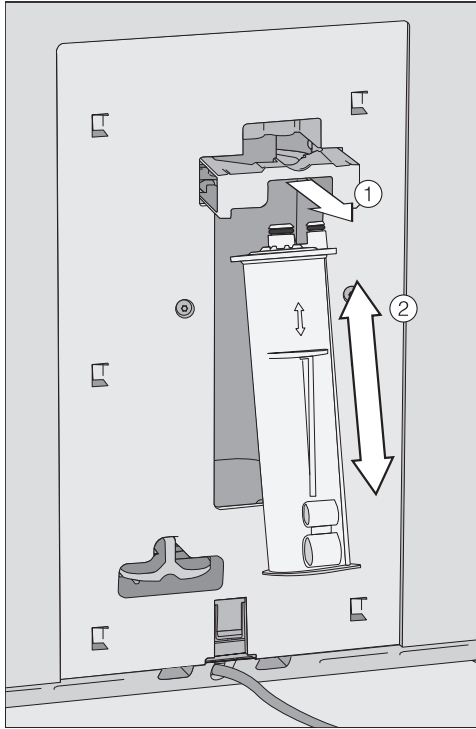

- Pull the cartridge holder ① forwards.

If there is already a cartridge fitted:

- Remove the cartridge ②.

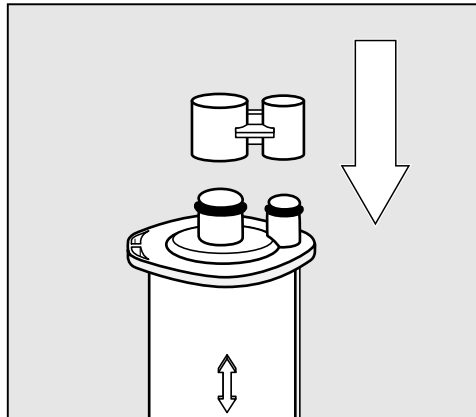

- Seal the cartridge with the cap.

The cap is located on the cartridge. Release it by snapping it off.

- Dispose of the empty cartridge with your household waste.

When not using a descaling cartridge

If you do not want to fit a descaling cartridge, the system must be sealed with the plug. Messages such as "Fit a new descaling cartridge" will not be displayed.

- Remove the descaling cartridge.

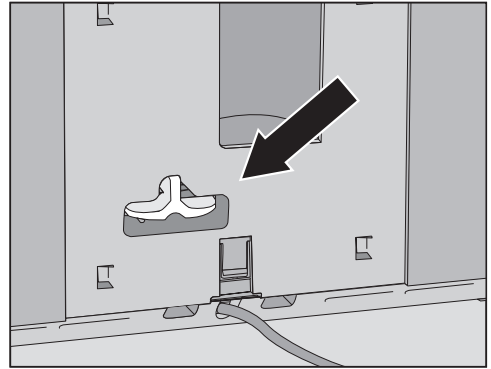

- Fit the plug instead of the descaling cartridge.

If you remove the descaling cartridge, automatic descaling is deactivated. You will then need to descale manually using the *Descal the machine* maintenance programme. To do this, the appropriate descaling agent is required (see "Cleaning and care - Descaling the appliance").



Start time for automatic descaling (Descaling timer).

You can set the daily start time for automatic descaling as you wish. The coffee machine must be switched off for the duration of the activation phase (approx. 30 minutes).

Automatic descaling is set at the factory to 4:00 am.

Setting the start time for automatic descaling

The **Drinks** menu is shown in the display.

- Touch .
- Touch **Settings** .
- Touch **Timer**.
- Touch **Descaling timer**.
- Set the required start time.
- Confirm with *OK*.

The start time is saved. From now on automatic descaling will commence at the desired time each day.

Cancelling automatic descaling

You can cancel automatic descaling during the activation phase.

Automatic descaling can be cancelled as often as you like. You would then need to descale the coffee machine manually using the descaling tablets (see "Cleaning and care - Descaling the appliance").

- Touch the On/Off  sensor.

The time left is shown in the display.

- Touch **Cancel**.

The descaling solution is rinsed out of the pipework. Rinsing can take up to 5 minutes. You can make drinks afterwards.

Problem solving guide

Many malfunctions and minor faults that can occur in daily operation can be corrected without contacting Miele. This will save you time and money because you will not need a service call.

You can find information on how to remedy faults yourself at www.miele.com.au/service or www.miele.co.nz/service and on the Miele website.

Please note, however, that a call-out charge will be applied to unnecessary service visits where the problem could have been rectified as described in these operating instructions.

Messages in the display

Error messages must be confirmed with *OK*. Otherwise the message may reappear in the display even though the problem has been remedied.

Follow the instructions which appear in the display to remedy the problem.

If the fault message appears again in the display, contact Miele.

| Problem | Possible cause and remedy |
|---|---|
| F1, F2, F80, F82 | There is an internal fault. ■ Switch the coffee machine off with the On/Off ① sensor. Wait for approximately one hour before switching the machine back on again. |
| F41, F42, F74, F77, F225, F226, F235, F236 | There is an internal fault. ■ Switch the coffee machine off with the On/Off ① sensor. Wait for approximately 2 minutes before switching the machine back on again. |

Problem solving guide

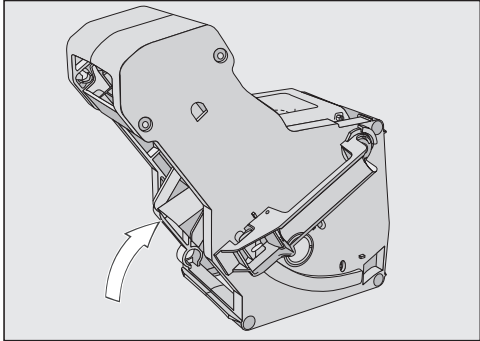
| Problem | Possible cause and remedy |
|--|--|
| <p>F73 or Check the brew unit</p> | <p>The brew unit cannot be positioned correctly.</p> <ul style="list-style-type: none">■ Switch the coffee machine off with the On/Off ① sensor.■ Remove the brew unit and clean it by hand.  <ul style="list-style-type: none">■ Push the coffee ejector of the brew unit into the correct position (see diagram).■ Do not fit the brew unit. Close the appliance door and switch the machine on with the On/Off ① sensor. <p>This will initialise the brew unit motor and put it back into the start position.</p> <ul style="list-style-type: none">■ When Insert the brew unit appears in the display, open the appliance door and put the brew unit back in the machine. Close the appliance door. <p>If the message appears again, reduce the amount of coffee and/or select a finer grinder setting. Some types of coffee have a much higher grinding volume.</p> |

Problem solving guide

| Problem | Possible cause and remedy |
|-------------------------|--|
| F233 | <p>The cup rim sensor is not inserted or is incorrectly inserted.</p> <p>The stainless steel cover of the central spout was not fitted properly, e.g. is tilting forwards slightly.</p> <p>If the central spout is moving upwards and the cup rim sensor is bumped, e.g. with a cup, the cup rim sensor loses its reference position.</p> <ul style="list-style-type: none">■ Confirm with <i>OK</i>.■ Switch the coffee machine off with the On/Off ⓪ sensor. Wait for at least 30 minutes before switching the machine back on again. Alternatively, disconnect the appliance from the electricity supply by switching off at the wall socket and withdrawing the power plug, or switching off the mains circuit breaker.■ Refit the cup rim sensor.■ Refit the stainless steel cover. Make sure the cover is seated correctly. |
| F355, F357– F362 | <p>The bean system must be set up again, e.g. coffee beans have possibly got jammed.</p> <ul style="list-style-type: none">■ Switch the coffee machine off with the On/Off ⓪ sensor. Wait for 30 minutes before switching the machine back on again. |

Unusual performance of the coffee machine

| Problem | Possible cause and remedy |
|--|--|
| <p>The lighting remains off after the coffee machine is switched on.</p> | <p>The lighting has been switched off.</p> <ul style="list-style-type: none"> ■ Switch the lighting on (see "Settings - Lighting"). |
| | <p>The lighting is faulty.</p> <ul style="list-style-type: none"> ■ Call Miele. |
| <p>The display remains dark when the coffee machine is switched on using the On/Off ① sensor.</p> | <p>The On/Off ① sensor was not touched for long enough.</p> <ul style="list-style-type: none"> ■ Touch and hold the On/Off ① sensor for at least 3 seconds. |
| | <p>The plug is not properly inserted into the socket or the socket is not switched on.</p> <ul style="list-style-type: none"> ■ Insert the plug into the socket correctly and switch on. |
| | <p>The mains fuse has tripped because the coffee machine, mains voltage or another appliance is defective.</p> <ul style="list-style-type: none"> ■ Switch off at the wall socket and remove the plug. ■ Contact a qualified electrician or Miele. |
| <p>The coffee machine switches off suddenly.</p> | <p>The factory set switch-off time (20 minutes) or the switch-off time you have programmed has been reached.</p> <ul style="list-style-type: none"> ■ If required, you can select a new switch-off time (see "Settings - Timer"). |
| | <p>The plug is not properly inserted into the socket or the socket is not switched on.</p> <ul style="list-style-type: none"> ■ Insert the plug into the socket correctly and switch on. |
| <p>The coffee machine is switched on. The lighting switches off suddenly.</p> | <p>This is not a fault. The lighting switches off automatically if the coffee machine is not used for some time. The automatic switch-off time cannot be changed.</p> |
| <p>The sensors do not respond to touch. The appliance cannot be operated.</p> | <p>There is an internal fault.</p> <ul style="list-style-type: none"> ■ Disconnect the appliance from the electricity supply by switching off at the wall socket and withdrawing the power plug, or switching off the mains circuit breaker. |

Problem solving guide

| Problem | Possible cause and remedy |
|--|---|
| <p>The coffee machine does not switch itself on, although the <small>Switch on at</small> setting has been activated for the timer.</p> | <p>The system lock has been activated.</p> <ul style="list-style-type: none"> ■ Deactivate the system lock. <hr/> <p>A day of the week has not been selected and/or the timer has not been activated.</p> <ul style="list-style-type: none"> ■ Check and change the timer settings if necessary. <hr/> <p>The machine was not used after being switched on automatically three times in succession.</p> <ul style="list-style-type: none"> ■ Switch the machine on and dispense a drink. <hr/> <p>The coffee machine does not switch on with the <small>Switch on at timer</small> while automatic descaling is being carried out. This is not a fault. Select a different timer setting.</p> |
| <p>Fill and refill the water container appears in the display even though the water container is full and in the machine.</p> | <p>The water container is not in the correct position.</p> <ul style="list-style-type: none"> ■ Remove the water container and push it back in again. ■ Clean the surface underneath the water container if necessary. <hr/> <p>During the <small>Descal</small> the machine maintenance programme the water container was not correctly filled and refitted.</p> <ul style="list-style-type: none"> ■ Fill the water container to the descaling symbol  and restart the descaling programme. <hr/> <p>The water container filter is blocked.</p> <div data-bbox="400 1002 879 1343" data-label="Image"> </div> <ul style="list-style-type: none"> ■ Clean the water container filter (see “Cleaning and care - Removing and cleaning the water container filter”). |

Problem solving guide

| Problem | Possible cause and remedy |
|---|--|
| <p>Fill and refit the water container appears after switching on even though the container is filled and fitted in the machine. The appliance does not rinse.</p> | <p>The descaling cartridge is not fitted. The coffee machine needs descaling.</p> <ul style="list-style-type: none"> ■ Switch the coffee machine off with the On/Off ① sensor. ■ Wait approx. one hour. ■ Switch the coffee machine back on. ■ As soon as Heating-up phase appears, touch Mainten.. ■ Touch Descale the machine. ■ Descale the coffee machine. |
| <p>The bean containers are empty and the message Fill the bean container does not appear.</p> | <p>The fill level sensors in the bean containers are dirty.</p> <ul style="list-style-type: none"> ■ Remove the coffee beans from the bean containers, e.g. with a vacuum cleaner. <div data-bbox="400 616 878 959" data-label="Image"> </div> <ul style="list-style-type: none"> ■ Clean the fill level sensors (see illustration) with a soft, dry cloth. |
| <p>Insert the drip tray and the waste container appears in the display, even though both have been inserted.</p> <p>Although the drip tray has been emptied, Empty the drip tray and the waste container appears in the display.</p> | <p>The drip tray is not correctly fitted and is therefore not detected.</p> <ul style="list-style-type: none"> ■ Empty the drip tray and the waste container if necessary. ■ Reassemble all parts and push the drip tray back in the coffee machine until it clicks. |

Problem solving guide



| Problem | Possible cause and remedy |
|---|--|
| <p>The waste container is overflowing even though the drip tray and grounds container have been emptied following each reminder.</p> | <p>The drip tray has probably been removed without the waste container being emptied. Removing the drip tray resets the internal counter for emptying the waste container.</p> <ul style="list-style-type: none"> ■ Always empty the waste container if you remove the drip tray. <p>Certain types of beans produce a lot of coffee when they are ground, meaning that larger coffee pucks are pressed.</p> <ul style="list-style-type: none"> ■ Adjust the quantity of coffee and grinder setting if necessary. ■ Empty the waste container more often than indicated in the display. |
| <p>The brew unit cannot be removed.</p> | <p>The brew unit drive is not in the correct position because the appliance door was opened during the grinding or brewing process, for example.</p> <ul style="list-style-type: none"> ■ If necessary, move the handle on the brew unit back to the start position. Close the appliance door. ■ Switch the coffee machine off with the On/Off  sensor. ■ Disconnect the electricity supply by switching off at the wall socket and withdrawing the plug, or switching off the mains circuit breaker. ■ Wait approx. 1 minute before reconnecting the coffee machine to the electricity supply and switching it on. <p>This will initialise the brew unit drive and put it back into the start position.</p> <ul style="list-style-type: none"> ■ If necessary, repeat these steps. |
| <p>Coffee is not flowing out of the central spout. Or coffee is only being dispensed via one spout.</p> | <p>The central spout has a blockage.</p> <ul style="list-style-type: none"> ■ Rinse the coffee pipework (see “Cleaning and care - Rinsing the appliance”). <p>If there is still no coffee coming out, or coffee is only coming out of one side:</p> <ul style="list-style-type: none"> ■ Dismantle the central spout and clean all parts carefully. ■ Make sure all parts are reassembled correctly. |
| <p>Neither milk nor milk froth comes out of the central spout.</p> | <p>The milk pipework is blocked.</p> <ul style="list-style-type: none"> ■ Clean the central spout and milk pipework carefully with the brush. |

Problem solving guide

| Problem | Possible cause and remedy |
|--|---|
| <p>The milk sputters when it is dispensed. Hissing noises can be heard when milk is being heated up or frothed. Although the milk should be frothed, only hot milk comes out of the main dispenser.</p> | <p>The milk temperature is too high. Good milk froth can only be achieved with cold milk (below 10 °C).</p> <ul style="list-style-type: none"> ■ Check the temperature of the milk. |
| | <p>The central spout is not fitted correctly and is drawing in air. Or the spouts are blocked.</p> <ul style="list-style-type: none"> ■ Check whether the central spout has been assembled correctly. Make sure that all parts are tightly connected to one another. ■ Clean the central spout. Rub the spouts under running water to loosen any soiling. |
| | <p>The milk pipework, connecting pieces, or the stainless steel tube of the milk flask are blocked.</p> <ul style="list-style-type: none"> ■ Clean all parts thoroughly with the cleaning brush. |
| | <p>The steam jet on the central spout has a blockage.</p> <ul style="list-style-type: none"> ■ Clean the steam jet with the cleaning brush (max. 1 cm wide). |
| <p>A fan can be heard even though no drinks are being prepared and the coffee machine is switched off.</p> | <p>This is not a fault. Once a drink has been dispensed or the machine has been switched off, the internal fan will continue to run until the interior is sufficiently dehumidified.</p> |
| <p>The display lights up but the coffee machine does not heat up and no drinks are made. The coffee machine cannot be switched off.</p> | <p>The Demo mode of the coffee machine for Miele Experience Centres and Chartered Agents has been activated.</p> <ul style="list-style-type: none"> ■ Deactivate Demo mode. |

Problem solving guide

Faults with automatic descaling

| Problem | Possible cause and remedy |
|---|---|
| <p>After switching on, a message appears informing you that automatic descaling could not be carried out.</p> | <p>If you have made drinks with milk, the milk tube must be pushed into the drip tray and when the machine is switched off, the message about this in the display confirmed with <i>OK</i>.</p> <p>All removable parts, such as the water container, drip tray, brew unit or central spout must be fitted.</p> <p>The water container must be filled with water at least up to the descaling symbol  (at least 500 ml water).</p> <p>The appliance door was not closed.</p> <ul style="list-style-type: none"> ■ Confirm the message with <i>OK</i>. ■ Make sure that the coffee machine is ready to use before the next descaling process. <p>The coffee machine was not switched off at the start time using the On/Off  sensor.</p> <p>The coffee machine pipework will only be filled with descaling solution when the coffee machine is switched off.</p> <ul style="list-style-type: none"> ■ Confirm the message with <i>OK</i>. ■ Change the start time if necessary. |
| <p>Descaling appliance manually appears in the display even though a descaling cartridge which is ready to use is fitted. Drinks cannot be made.</p> | <p>Depending on the water hardness level in your area and your usage behaviour, the coffee machine needs to be descaled using the maintenance programme occasionally.</p> <p>For this you will need to use Miele descaling tablets.</p> <ul style="list-style-type: none"> ■ Descal the coffee machine using the maintenance programme (see “Cleaning and care - Descaling the appliance”). |
| <p>The message The descaling process could not be carried out. Replace the cartridge with a new one appears after switching on.</p> | <p>The descaling cartridge is empty. You can still make drinks today.</p> <ul style="list-style-type: none"> ■ Confirm the message with <i>OK</i>. ■ Insert a new descaling cartridge. |

Unsatisfactory results

| Problem | Possible cause and remedy |
|--|--|
| <p>The coffee is not hot enough.</p> | <p>The cup has not been pre-heated. The smaller the cup and the thicker its walls, the more important it is to pre-heat it.</p> <ul style="list-style-type: none"> ■ Pre-heat the cups, e.g. using the cup heating function (depending on model). |
| | <p>The brewing temperature is set too low.</p> <ul style="list-style-type: none"> ■ Set a higher brewing temperature. |
| | <p>The filters in the brew unit are blocked.</p> <ul style="list-style-type: none"> ■ Remove the brew unit and clean it by hand. ■ Degrease the brew unit. |
| <p>Drinks are being dispensed from the central spout considerably more slowly. The heating-up time is getting longer and the coffee machine is not performing properly.</p> | <p>The coffee machine needs descaling. If you use hard water (> 20 °dH / 3.6 mmol/l) or if the coffee machine is used intensively, it may be necessary to descale the machine manually more frequently.</p> <ul style="list-style-type: none"> ■ Run the Descal the machine maintenance programme. You will need one descaling tablet. |
| <p>The consistency of the milk froth is unsatisfactory.</p> | <p>The milk temperature is too high. Good milk froth can only be achieved with cold milk (below 10 °C).</p> <ul style="list-style-type: none"> ■ Check the temperature of the milk in the milk flask. |
| | <p>The milk pipework is blocked.</p> <ul style="list-style-type: none"> ■ Clean the central spout and milk pipework with the brush. |
| <p>The coffee grinder makes a louder noise than usual.</p> | <p>The coffee bean container has become empty during the grinding process.</p> <ul style="list-style-type: none"> ■ Fill the coffee bean container with fresh beans. |
| | <p>There may be foreign objects such as plastic or stones in amongst the coffee beans.</p> <ul style="list-style-type: none"> ■ Switch the coffee machine off immediately. Call Miele. |

Problem solving guide

| Problem | Possible cause and remedy |
|--|--|
| <p>There is no crema on the coffee or espresso.</p> | <p>The coffee beans are no longer fresh. If roasted coffee beans are stored open for too long, the carbon dioxide gradually escapes from the coffee beans. The crema is therefore no longer formed during dispensing. Of course, you can still use the coffee beans.</p> |
| <p>The coffee tastes weak. The coffee grounds in the waste container are sludgy and grainy.</p> | <p>Insufficient coffee beans are getting into the grinder and less coffee is being brewed. Have you used a dark roast? This type of coffee bean is often oily. These oils can cling to the inside of the coffee bean containers and hinder the flow of beans.</p> <ul style="list-style-type: none"> ■ Make a coffee and observe whether the coffee beans drop into the coffee bean container. ■ Clean the coffee bean containers more often if you are using darker, more oily coffee beans. <p>Try other types of coffee beans which are less oily.</p> <p>Insufficient coffee beans are getting into the grinder and less coffee is being brewed. Are you using a coffee blend with very large beans or different sized beans? The beans are possibly getting wedged or jammed and forming “bean bridges”.</p> <div style="border: 1px solid gray; padding: 5px; margin: 5px 0;"> <p> Danger of injury on the moving grinder! If you place a spoon or similar, or even fingers, in the bean containers during grinding, you could be injured. Do not reach into the bean system during grinding. Do not place any objects in the bean containers during grinding.</p> </div> <ul style="list-style-type: none"> ■ Place a narrow spoon or similar in the bean containers and stir the coffee beans. <p>The ground coffee chute is blocked.</p> <ul style="list-style-type: none"> ■ Vacuum out the ground coffee chute using the attachment supplied. |

You can find information on how to remedy faults yourself and about Miele spare parts at www.miele.com.au/service or www.miele.co.nz/service.

Contact in case of fault

In the event of any faults which you cannot remedy yourself, please contact Miele.

You can book a Miele customer service call-out online at www.miele.com.au/service or www.miele.co.nz/service.

Contact information for Miele can be found at the end of this booklet.

Please quote the model and serial number of your appliance when contacting Miele. This information can be found on the data plate.

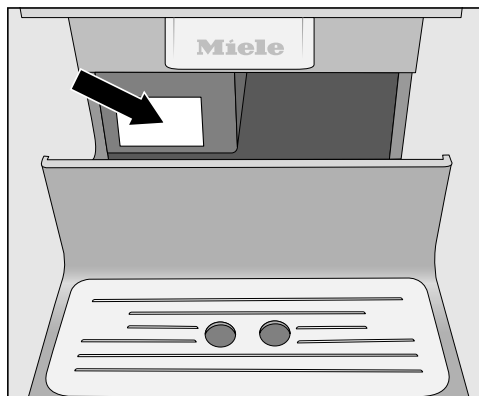

Warranty

The manufacturer's warranty for this appliance is 2 years.

For further information, please refer to your warranty booklet.

Transporting the machine

If you are not going to use the coffee machine for an extended period of time and you intend to transport it, e.g. when moving house, a number of procedures will need to be carried out:

- Empty and clean the coffee bean container
- Empty and clean the water container
- Evaporate the coffee machine
- Remove the descaling cartridge and insert the plug
- Vacuum out the ground coffee chute using the attachment
- Clean the interior of the machine
- Pack the machine securely



Evaporating the coffee machine

The coffee machine pipework should be evaporated before it is stored for a long period of time or transported any distance - particularly at temperatures below freezing.

Evaporating the appliance involves removing all traces of water from the system to prevent the risk of water and frost damage.

The **Drinks** menu is shown in the display.

 **Danger of burning and scalding on the dispensing spouts.**
Hot steam can cause scalding.
Keep well away from the area underneath the spouts when hot liquids or steam are being dispensed.
Do not touch hot components.

- Touch .
- Touch **Settings** .
- Touch **Service**.
- Touch **Evaporate**.

- Touch **Yes** to confirm.
- Follow the instructions in the display.

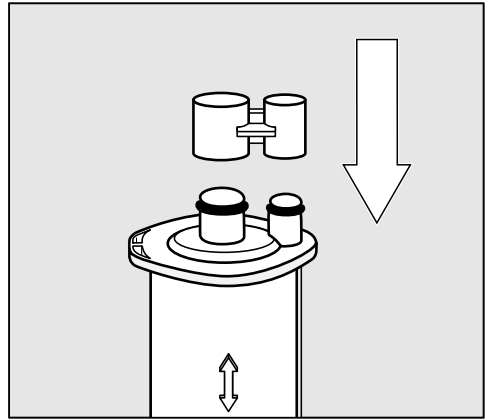

- Remove the descaling cartridge and seal it with the cap.

Once filled with water, the descaling cartridge has a max. shelf life of three weeks outside of the machine. The cartridge should be stored upright, in a dark place and at room temperature (16 - 38 °C).

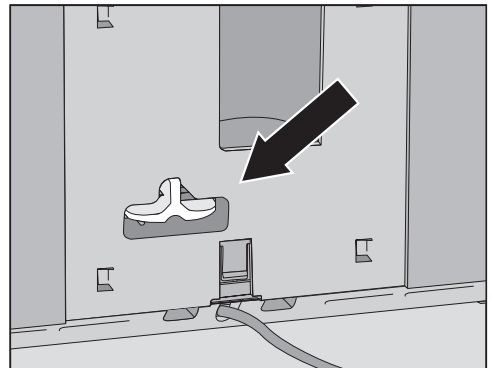

- Insert the plug in place of the cartridge.

When the display goes out, the machine has finished evaporating.

- Clean the drip tray and waste container.

Vacuuming out the ground coffee chute using the attachment and cleaning the interior

To ensure coffee residues are removed thoroughly, you should vacuum out the ground coffee chute before transporting and clean out the interior of the machine carefully.

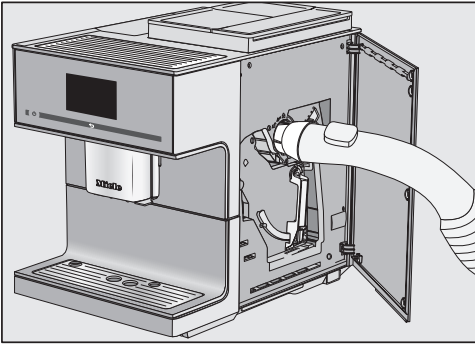

- Attach the vacuum cleaner attachment included in the scope of delivery.
- Use the suction tube of your vacuum cleaner to vacuum out the ground coffee chute.
- Remove the brew unit.
- Clean the inside of the appliance.

Useful tip: You can also use your vacuum cleaner to remove any dry ground coffee residues.

- Clean the brew unit before refitting it.

Packing the coffee machine securely

Always use a clean and dry appliance. Ground coffee residues can scratch the surfaces. In addition, coffee, milk and water residues cause a build-up of bacteria.

Use the original packaging to pack the coffee machine.

Keep the operating instructions in the box. This means that you have them to hand if you want to reuse the coffee machine.

Accessories

These products and other useful accessories can be ordered via the Miele webshop or directly from Miele (see back cover for contact details).

- **Original Miele all purpose microfibre cloth**
For removing finger marks and light soiling
- **Cleaning agent for milk pipework**
For cleaning the milk system
- **Cleaning tablets**
For degreasing the brew unit
- **Descaling cartridge**
for automatic descaling
- **Descaling tabs**
For manual descaling

Before connecting the coffee machine, make sure that the connection data on the data plate (voltage and frequency) matches the mains electricity supply. This data must correspond in order to avoid the risk of damage to the coffee machine. If in any doubt, consult a qualified electrician.

The connection data is given on the data plate. The data plate can be seen on the left-hand side when the drip tray is pulled out.

The machine is supplied with a mains cable with moulded plug for connection to a 50 Hz 220-240 V supply.

The coffee machine must be connected to the mains supply via a suitable switched socket with earthing contact. Connection must comply with national and local safety regulations.

The fuse rating must be at least 10 A.

The socket should be next to the appliance and be easily accessible.

Do not connect the machine to the mains electricity supply by a multi-socket adapter or an extension lead. These do not guarantee the safety of the appliance (e.g. risk of fire).

Temporary or permanent operation with a self-sufficient or non-mains synchronous energy supply system (e.g. isolated networks, back-up systems) is possible. A requirement for the operation is that the energy supply system complies with all current local and national requirements that apply to stand-alone, solar and/or battery systems.

The protective measures provided in the domestic installation and in this Miele product must also be assured in their function and operation in isolated

operation or in non-mains synchronous operation, or replaced with equivalent measures in the installation.

The coffee machine must not be used with **energy-saving plugs**. These reduce the amount of energy supplied to the machine, causing it to overheat.

If the mains connection cable is faulty, it must only be replaced by a qualified electrician in order to avoid a hazard.

Appliance dimensions

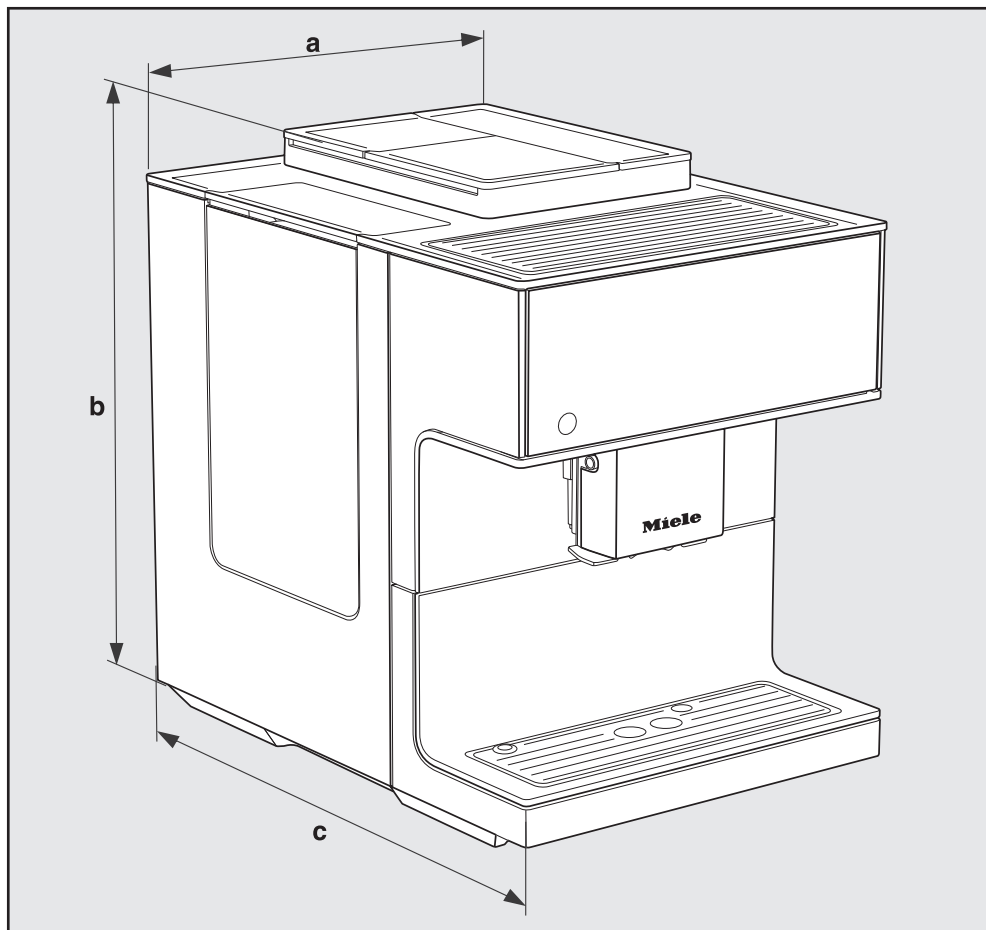

a = 311 mm

b = 420 mm

c = 445 mm

Technical data

| | |
|---|-------------------------------------|
| Electricity consumption in standby: | < 0.4 Watt |
| Electricity consumption in networked standby: | < 0.9 Watt |
| Pump pressure: | max. 15 bar |
| Through-flow heater: | 1 stainless steel thermo block |
| Appliance dimensions (W x H x D): | 311 x 420 x 445 mm |
| Net weight: | 14.2 kg |
| Mains connection cable length: | 120 cm |
| Water container capacity: | 2.2 l |
| Total capacity of bean containers: | |
| Coffee bean container A: | Approx. 540 g |
| Coffee bean container B: | Approx. 150 g |
| Coffee bean container C: | Approx. 210 g |
| | Approx. 180 g |
| Milk flask capacity: | 0.5 l |
| Drip tray capacity: | 0.8 l |
| Waste container capacity: | max. 16 portions of coffee grounds |
| Central spout: | Height-adjustable between 80–160 mm |
| Grinder: | Conical steel grinder |
| Grinder setting: | 5 settings |
| Ground coffee amount: | max. 12 g |
| Frequency band: | 2.400 – 2.4835 GHz |
| Max. transmission power | < 100 mW |

Miele Australia Pty. Ltd.

ACN 005 635 398

ABN 96 005 635 398

Level 4, 141 Camberwell Road
Hawthorn East, VIC 3123

1300 464 353 (1300 4 MIELE)

info@miele.com.au

www.miele.com.au

Miele New Zealand Limited

IRD 98 463 631

8 College Hill
Freemans Bay, Auckland 1011

0800 464 353 (0800 4 MIELE)

customercare@miele.co.nz

www.miele.co.nz

Miele Global Headquarters

Germany

Miele & Cie. KG

Carl-Miele-Straße 29

33332 Gütersloh

Federal Republic of Germany

CM 7750 CoffeeSelect

en – AU, NZ

M.-Nr. 12 638 740 / 00