

Installation plan  
Commercial washing machine  
PW 6321 D

---

To avoid the risk of accidents or damage to the machine, it is **essential** to read these instructions before it is installed and used for the first time.







en-GB

# Contents

---

<b>Installation notes</b> .....	<b>3</b>
Explanation of the safety notes and warnings on the machine .....	3
Installation requirements .....	3
General operating conditions .....	3
Installation .....	3
Electrical connection .....	4
Water connection .....	5
Cold water connection.....	5
Hot water connection .....	5
Hard water connection .....	6
Drain valve .....	6
Dispenser pump connections .....	6
Optional accessories .....	8
BSK = Payment system kit.....	8
BSS peak-load negotiation kit .....	8
XKM RS232 communication module.....	8
Vapour and foam venting kit (APWM 063) .....	9
<b>Installation</b> .....	<b>10</b>
Installation (direct steam heating) .....	10
Installation (indirect steam heating) .....	12
<b>Installation</b> .....	<b>14</b>
Dimensions .....	14
Standard floor anchoring.....	15
SOM floor anchoring .....	15
<b>Technical data</b> .....	<b>16</b>
Voltage versions and electrical data .....	16
Connection for equipotential bonding.....	16
Steam connection .....	16
Water connections .....	17
Cold water connection.....	17
Hot water connection .....	17
Hard water connection .....	17
Condensate connection (indirect steam heating only) .....	17
Waste water (drain valve).....	17
Securing the machine .....	17
Fittings.....	17
Floor anchoring .....	17
Emissions .....	18
Machine data .....	18
Transport data.....	18

## Explanation of the safety notes and warnings on the machine

	Read the operating instructions
	Read all the instructions, e.g. the installation instructions
	Warning, hot surfaces
	Warning, voltage up to 1000 volts
	Protective earthing
	Protective equipotential bonding

## Installation requirements

The washing machine must be installed and commissioned by a Miele Service technician or by an authorised dealer.

- ▶ The washing machine must be installed in accordance with applicable regulations and standards. Local energy supplier and water authority regulations must also be observed.
- ▶ This washing machine must only be operated in a room that has sufficient ventilation and which is frost-free.

This machine should not be installed or operated in any area where there is a risk of explosion!

## General operating conditions

This washing machine is intended only for use in a commercial environment and must only be operated indoors.

- Ambient temperature: 0-40 °C
- Relative humidity: non-condensing
- Maximum height above sea level of location site: 2000 m

Depending on the nature of the installation site, sound emissions and vibration may occur.

**Tip:** Have the installation site inspected and seek the advice of a professional in instances where increased noise may cause a nuisance.

## Installation

Transport the washing machine to its installation site using a suitable pallet truck and remove the transport packaging.

The washing machine must be set up on a completely level, horizontal and firm surface with the minimum stated load bearing capacity (see "Technical data").

## Installation notes

---

**Tip:** A concrete floor is the most suitable installation surface. It is far less prone to vibration during the spin cycle than wooden floorboards or a carpeted surface.

The floor load created by the washing machine is the load exerted by the area of the machine in contact with and transferred to the installation surface.

The washing machine requires a gap of at least 50 mm on each side to allow for movement during operation. Please ensure a minimum distance of 400 mm is maintained between the rear of the appliance and the rear wall.

The washing machine must not be installed on a carpeted floor.

The feet of the washing machine must be secured to the fastening points on the floor using the fittings supplied.

The fittings supplied are for bolting the machine to a concrete floor. If other floor types are present at the installation site, the fastening material must be ordered by the customer.

### Electrical connection

The electrical connection must only be carried out by a qualified electrician who must ensure that all electrical work is carried out in accordance with applicable electrical regulations and standards (BS 7671 in the UK).

► This washing machine must be connected to an electrical mains supply that complies with local and national regulations. Please also observe your insurance and energy supplier's regulations as well as any health and safety at work regulations.

► The required voltage, connected load and fusing rating can be found on the data plate on the washing machine. Before connecting the machine to the power supply, please ensure that the mains supply voltage complies with the values given on the data plate.

Connection to a supply voltage other than the one quoted on the data plate can lead to functional faults and damage the washing machine!

If more than one voltage is quoted on the data plate, the washing machine can be converted for connection to the voltages stated.

► Conversion to a different voltage must only be carried out by a Miele Service engineer or by an authorised Service Partner. The wiring instructions given on the wiring diagram must be followed.

**Tip:** We recommend connection to the power supply via a suitably rated plug and socket which must be easily accessible for servicing and maintenance work after the machine has been installed. An electrical safety test must be carried out after installation and after any service work.

The machine should be connected with a suitably rated plug and socket in accordance with IEC 60309-1 or hard wired. For a hard wired connection an all-pole isolation device must be installed.

For hard-wired machines connection should be made via a suitable mains switch with all-pole isolation which, when in the off position, ensures a 3 mm gap between all open contacts. These include circuit breakers, fuses and relays (IEC/EN 60947).

If the mains supply cannot be permanently disconnected, the isolator switch (including plug and socket) must be safeguarded against being switched on either unintentionally or without authorisation.

► If it is necessary to install a residual current device (RCD) in accordance with local regulations, a residual current device type B (sensitive to universal current) must be used.

An existing type A residual current device (RCD) must be exchanged for a type B RCD.

An equipotential bond with good contact connection must always be provided in accordance with all national and local regulations.

Accessories for equipotential bonding are not supplied and need to be ordered separately.

### Water connection

The flow pressure must amount to a minimum of 100 kPa and must not exceed 1000 kPa. If the flow pressure is higher than 1000 kPa, a pressure reducing valve must be used.

The machine must be connected to the water supply using the inlet hoses provided.

⚠ The connection points are subject to water supply pressure. Turn on the stopcock slowly and check for leaks. Correct the position of the seal and screw thread if appropriate.

Only connect the washing machine to the water supply with the hoses supplied.

#### Cold water connection

For the cold water connection, one stopcock each with a  $\frac{3}{4}$ " external thread is required.

The water inlet hose for cold water (blue stripes) is not intended to be used with a hot water connection.

#### Hot water connection

To minimise energy consumption during operation with hot water, the washing machine should be connected to a suitable hot water ring circuit if present.

So-called "transmission pipes" (single pipes to hot water generators) can result in cooling down of the water remaining in the pipes if not in constant use. More energy would then be consumed to heat the suds up again.

The temperature of the water intake must not exceed 60 °C.

If there is no hot water supply at the installation location for the washing machine, the inlet hose for hot water must also be connected to the cold water supply. A Y-piece is required in this case. The cold water consumption increases accordingly to account for the missing hot water intake.

## Installation notes

---

For functional and technical reasons it is not possible to operate the machine exclusively with a hot water connection.

Even if a hot water connection is present, the washing machine must be connected to a cold water intake.

### Hard water connection

Connection for hard water. For the hard water connection, the same requirements apply as for the cold water connection.

If there is no hard water connection on site, the hose must be connected to the cold water connection.

### Drain valve

In the case of washing machines with a drain valve, a motorised valve is used to drain the machine. An HT DN 70 angle connector can be used for draining the machine directly into the waste water system (without a siphon) or into an on-site floor drain (with odour trap).

Thanks to an improved closing mechanism and a larger cross-section, even the coarsest of soiling does not leave any deposits or debris behind which could result in blockages. The drain valve can also be operated manually to allow the suds container to be emptied in the event of a power outage.

A vented drainage system is vital for unimpeded drainage.

If several machines are connected to a single drain pipe, this should be sufficiently large to allow all machines to drain simultaneously.

The appropriate Miele installation kit (mat. no.: 05 238 090) is available to order from the Miele Customer Service Department or your Miele dealer for venting an HT DN 70 pipe.

If the slope for drainage is extremely steep, the piping must be vented to prevent formation of a vacuum in the machine's drainage system.

Slow or obstructed drainage or a backup of water in the drum as a result of undersized pipework can result in faults occurring during programmes, which will result in fault messages appearing in the display.

 Outflowing suds can be as hot as 95 °C. Danger of burning!  
Avoid direct contact.

### Dispenser pump connections

Up to 12 dispenser pumps can be connected to the washing machine.

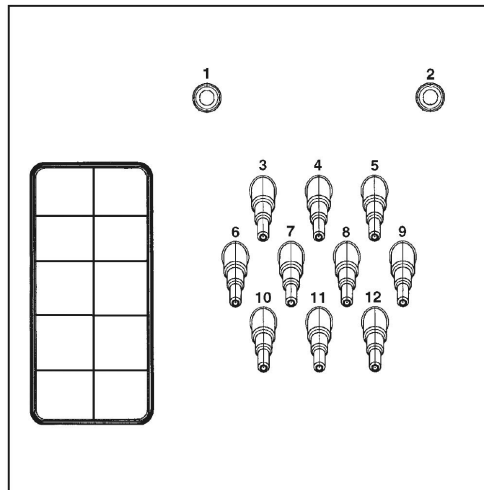

Dispenser pump connections on the back of the machine

Connections **1** and **2** are provided for viscous agents can also be used for high pressure dispensing systems with water injection. The dispensing systems must be fitted with a separate drinking water safety mechanism in accordance with EN 61770 and EN 1717. The maximum flow rate is 1500 ml/min with a maximum flow pressure of 300 kPa.

These connectors are sealed and need to be drilled open using a 8 mm drill bit before connecting.

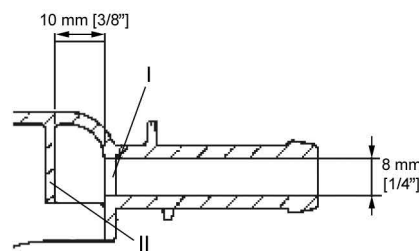

Make sure that you only drill through the first panel (**I**) as there is a deflecting panel (**II**) 10 mm behind it.

Connections **3** to **12** are provided for liquid detergent. High pressure dispensing systems with water injection must not be connected to these connections. The connectors are sealed and must be cut to the diameter of the hose with a small saw before they are connected.

If opened connectors are no longer required, they must be resealed using a suitable sealant (e.g. silicone).

Connection terminals for five time-controlled dispenser pumps, which can be operated without a multifunction module, are located behind the cover adjacent to the electrical connection.

Calibration of the dispenser pumps and regulation of dispensing quantities is carried out partly automatically for washing machines fitted with an optional multifunction module. Information regarding settings is given in the operating instructions.

A flowmeter or flow sensors can also be connected for monitoring the dispensing quantity precisely.

Connections for level monitoring are available for every agent dispensed.

## Installation notes

### Optional accessories

Only use genuine Miele spare parts and accessories with this machine.

Using spare parts or accessories from other manufacturers will invalidate the warranty, and Miele cannot accept liability.

#### **BSK = Payment system kit**

The washing machine can be equipped with a payment system (e.g. for self-service operations) using the optional BSK payment system kit. This must be connected and programmed by a Miele Service technician. Payment systems with mechanical or electronic coin validator are available from Miele as optional accessories for individual target groups.

The programming required for connecting a payment system must be carried out by Miele Service or an authorised Miele dealer only. A separate electrical connection is not required for a payment system.

#### **BSS peak-load negotiation kit**

The washing machine can be connected to a peak-load shut-off or an energy management system using a BSS peak-load negotiation kit which is available as an optional accessory.

The peak-load cut-out monitors the energy consumption of a system and deactivates individual pieces of equipment temporarily in order to ensure that certain total load limits are not exceeded. Monitoring is externally controlled.

The kit provides three signal contacts and a neutral conductor via a terminal block. The terminal block is marked with "a", "b", "c", and "d".

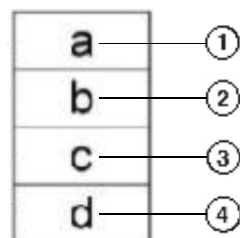

- ① Output signal, start of machine operation
- ② Output signal, machine heating request
- ③ Peak-load input signal, machine heating deactivated
- ④ Neutral conductor

When the peak-load function is activated the current programme is stopped and a message appears in the display on the washing machine. At the end of the peak-load function the programme resumes automatically.

#### **XKM RS232 communication module**

The serial interface RS-232 can be retrofitted to the washing machine via an XKM RS 232 (optional accessory available from Miele). This communication module must only be used with Miele Professional machines that are fitted with an appropriate slot for the module.



The data interface provided via communication module XKM RS232 complies with SELV (Safety Extra Low Voltage) in accordance with EN 60950.  
Appliances connected to this interface must also be SELV compliant.

Communication module XKM RS 232 is supplied with a connection cable and a D-sub-connector.

**Vapour and foam venting kit (APWM 063)**

If excessive suds form, foam may escape from the vapour vent. To remove the foam, an optional vapour and foam venting kit can be used.

# Installation

## Installation (direct steam heating)

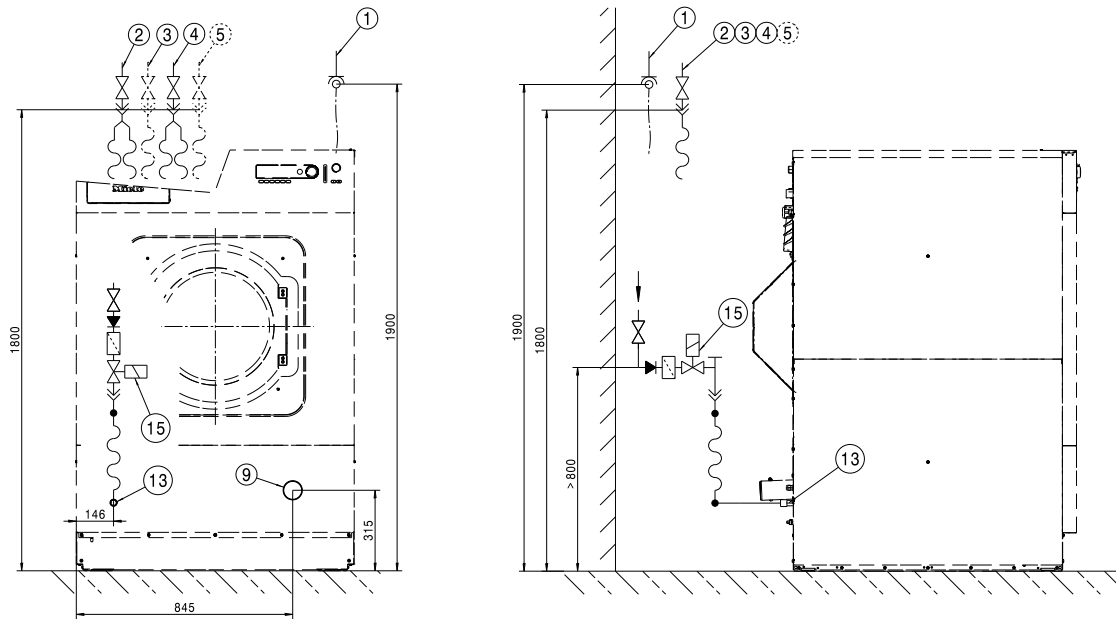

- ① Electrical connection
- ② Cold water connection
- ③ Hot water connection
- ④ Cold water connection (alternatively, hard water connection)
- ⑤ Cold water connection for liquid dispensing (optional)
- ⑥ Dispenser pump connections
- ⑦ Overflow
- ⑧ Communication connection
- ⑨ Drain pipe
- ⑩ Connection for equipotential bonding
- ⑬ SD connection (direct steam) SD only
- ⑭ Steam valve connection SI/SD only
- ⑮ Steam valve SI/SD only

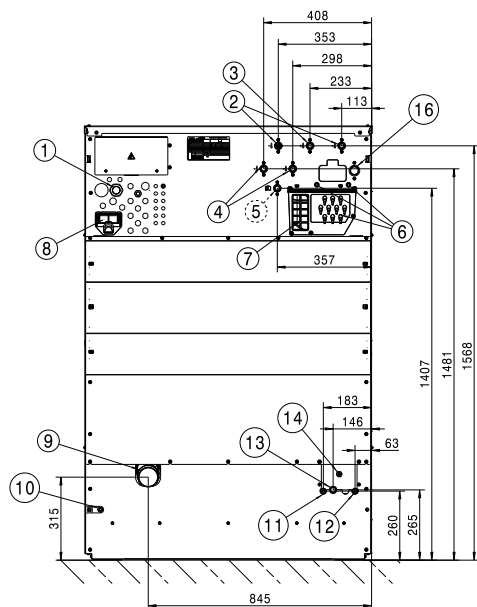

- |  |  |
|--|--|
| ① Electrical connection  | ⑨ Drain pipe                                     |
| ② Cold water connection  | ⑩ Connection for equipotential bonding           |
| ③ Hot water connection   | ⑪ SI connection, intake (indirect steam) SI only |
| ④ Cold water connection (alternatively, hard water connection) | ⑫ SI connection, drain (indirect steam) SD only  |
| ⑤ Cold water connection for liquid dispensing (optional)       | ⑬ SD connection (direct steam) SD only           |
| ⑥ Dispenser pump connections                                   | ⑭ Steam valve connection SI/SD only              |
| ⑦ Overflow   | ⑮ Steam valve SI/SD only                         |
| ⑧ Communication connection                                     | ⑯ Water recovery connection                      |

# Installation

## Installation (indirect steam heating)

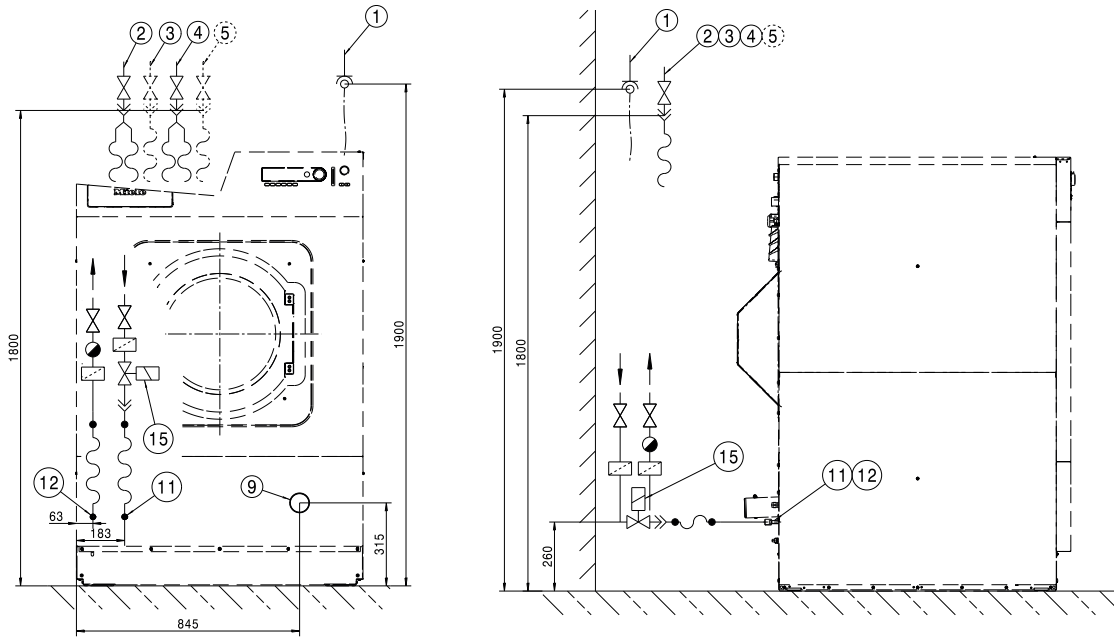

- ① Electrical connection
- ② Cold water connection
- ③ Hot water connection
- ④ Cold water connection (alternatively, hard water connection)
- ⑤ Cold water connection for liquid dispensing (optional)
- ⑥ Dispenser pump connections
- ⑦ Overflow
- ⑧ Communication connection
- ⑨ Drain pipe
- ⑩ Connection for equipotential bonding
- ⑪ SI connection, intake (indirect steam) SI only
- ⑫ SI connection, drain (indirect steam) SI only
- ⑬ SD connection (direct steam) SD only
- ⑮ Steam valve SI/SD only

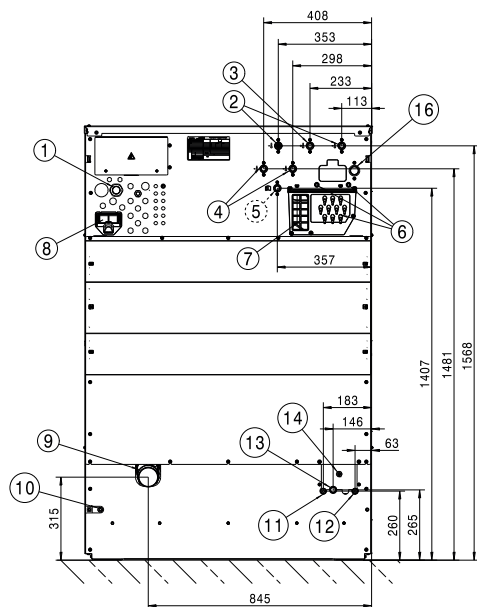

- ① Electrical connection
- ② Cold water connection
- ③ Hot water connection
- ④ Cold water connection (alternatively, hard water connection)
- ⑤ Cold water connection for liquid dispensing (optional)
- ⑥ Dispenser pump connections
- ⑦ Overflow
- ⑧ Communication connection
- ⑨ Drain pipe
- ⑩ Connection for equipotential bonding
- ⑪ SI connection, intake (indirect steam) SI only
- ⑫ SI connection, drain (indirect steam) SI only
- ⑬ SD connection (direct steam) SD only
- ⑭ Steam valve connection SI/SD only
- ⑮ Steam valve SI/SD only
- ⑯ Water recovery connection

# Installation

## Dimensions

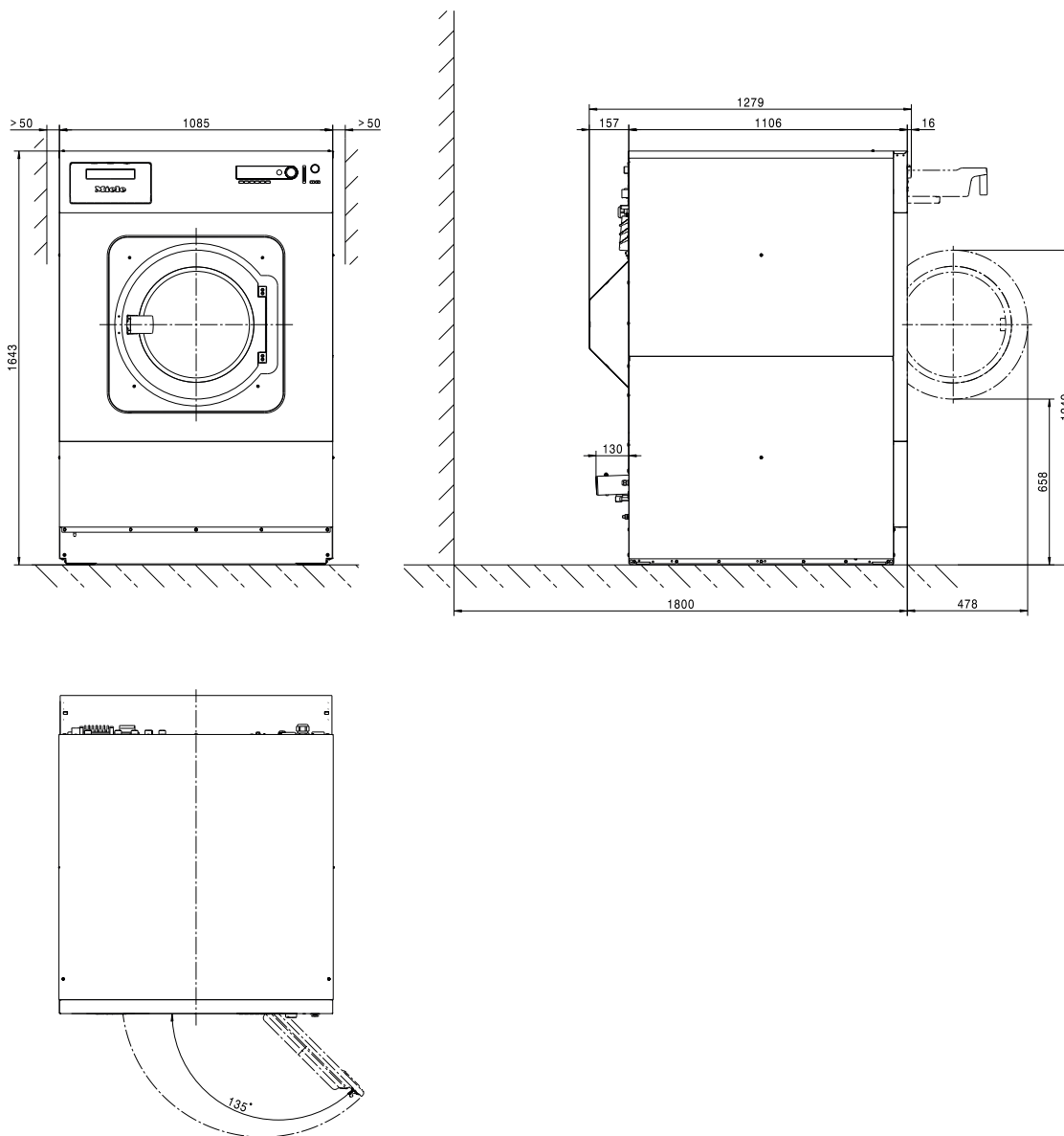

Dimensions in mm

### Standard floor anchoring

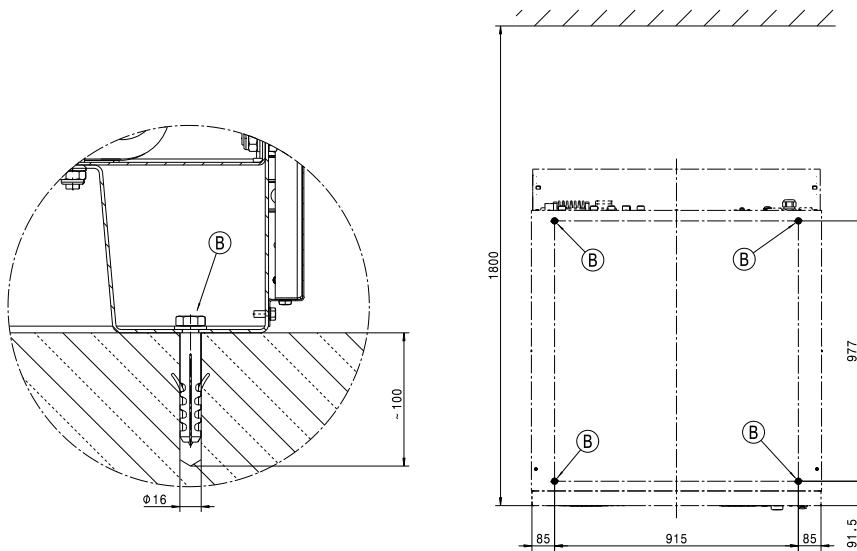

Dimensions in mm

Ⓑ screw/anchor point

### SOM floor anchoring

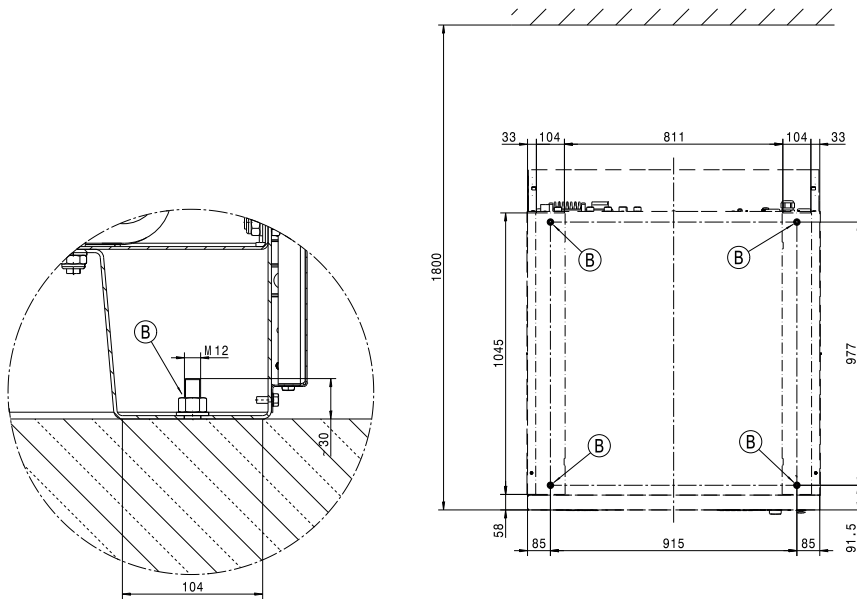

Dimensions in mm

Ⓑ screw/anchor point

# Technical data

## Voltage versions and electrical data

	<i>Standard:</i>	<i>Convertible to:</i>
Supply voltage	<b>3N AC 380-415V</b>	<b>3N AC 380-415V</b>
Frequency	50 Hz	60 Hz
Power rating	6,1 kW	6,1 kW
Fuse rating (on site)	3 x 16 A	3 x 16 A
Connection cable, min. cross-section	4 x 1,5 mm <sup>2</sup>	4 x 1,5 mm <sup>2</sup>
Cable gland	M16 x 1,5 mm	M16 x 1,5 mm
Supply voltage		<b>3 AC 400V</b>
Frequency		60 Hz
Power rating		6,1 kW
Fuse rating (on site)		3 x 16 A
Connection cable, min. cross-section		4 x 1,5 mm <sup>2</sup>
Cable gland		M16 x 1,5 mm

Miele recommends connecting the machine via a wall socket with an all-pole means of deactivation and interlock in accordance with IEC 60309 and IEC 60947 so that electrical safety checks can be carried out easily.

For hard-wired machines, an isolator in accordance with IEC 60947 must be installed.

The wall socket or isolator must remain accessible at all times once the machine has been installed.

To increase safety, Miele recommends installation of a residual current device (RCD). Only use residual current devices that are sensitive to universal current (type B).

## Connection for equipotential bonding

Connection with male thread (machine)	10 mm x 30 mm (3/8" x 1 3/16")
Size of washers and nuts	M 10

An  equipotential bond with good contact connection must always be provided in accordance with all national and local regulations.

## Steam connection

### Indirect steam heating

Steam overpressure	400–1000 kPa
Boiling point	152–184 °C
Heater rating (peak capacity)	50 kW
Mass flow (peak capacity)	84 kg/h
Threaded union (on site)	½" female thread

Steam solenoid valve, dirt filter and steam shut-off valve must be installed by the customer on site. Follow the installation instructions for steam-heated machines.

### Direct steam heating

Steam overpressure (high pressure)	≤ 400 kPa
Boiling point (high pressure)	≤ 152 °C
Heater rating (peak capacity high pressure)	86 kW
Mass flow (peak capacity high pressure)	140 kg/h
Steam overpressure (low pressure)	≤ 50 kPa
Boiling point (low pressure)	≤ 120 °C
Heater rating (peak capacity low pressure)	29 kW
Heater rating (peak capacity low pressure)	45 kg/h
Threaded union (on site)	¾" female thread

Steam solenoid valve, dirt filter and steam shut-off valve must be installed by the customer on site. Follow the installation instructions for steam-heated machines.



## Water connections

### Cold water connection

Required flow pressure	100–1000 kPa (1–10 bar)
Maximum flow rate (if no hot water and hard water supply)	74 (79,5*) l/min
Maximum flow rate	26 (31,5*) l/min
Threaded union required (male thread, to be provided by customer in accordance with DIN 44991, flat sealing)	3/4"
Length of water inlet hose supplied	2 (3*) x 1550 mm
*With liquid dispensing	

### Hot water connection

Maximum permissible hot water temperature	60 °C
Required flow pressure	100–1000 kPa (1–10 bar)
Maximum flow rate	16 l/min
Threaded union required (male thread, to be provided by customer in accordance with DIN 44991, flat sealing)	3/4"
Length of water inlet hose supplied	1 x 1550 mm

### Hard water connection

Required flow pressure	100–1000 kPa (1–10 bar)
Maximum flow rate	32 l/min
Threaded union required (male thread, to be provided by customer in accordance with DIN 44991, flat sealing)	3/4"
Length of water inlet hose supplied	2 x 1550 mm

### Condensate connection (indirect steam heating only)

Threaded union for condensate connection (on site)	½" female thread
--	------------------

Condensate trap, dirt filter and steam shut-off valve must be installed by the customer on site.

### Waste water (drain valve)

Maximum waste water temperature	95 °C
Machine-side drain connection (external diameter)	HT DN 70
On-site drain (internal diameter)	75 x 1,9 x 110 mm (Muffe DN 70)
Maximum flow rate	200 l/min

A vented combined pipe is required to drain the waste water. If several machines are connected to a single drain pipe, this should be sufficiently large to allow all machines to drain simultaneously.

## Securing the machine

### Fittings

4 x wood screws DIN 571 (Ø x length)	12 mm x 90 mm
4 x plugs (Ø x length)	16 mm x 80 mm

Fixing the machine in place is absolutely essential.

Fastenings for floating screed must be supplied by the customer on site.

### Floor anchoring

Required anchor points	4
DIN 571 wood screw (diameter x length)	12 mm x 90 mm
Rawl plugs (diameter x length)	16 mm x 80 mm

## Technical data

---

### Emissions

Average heat dissipation rate to installation room	6,1 MJ/h
Emission sound pressure level in the workplace	73 dB(A) re 20 µPa

### Machine data

Machine width (without add-on components)	1085 mm
Machine height (without add-on components)	1643 mm
Machine depth (without add-on components)	1106 mm
Machine width, total	1089 mm
Machine height, total	1646 mm
Machine depth, total	1279 mm
Minimum width of loading aperture (internal diameter)	1185 mm
Recommended distance between wall and front of machine	1800 mm
Net weight	648 kg
Maximum floor load during operation	8975 N
Maximum static load	7456 N
Maximum dynamic load	1520 N
Maximum rotation frequency of drum	16,7 Hz

Installation should only be performed by qualified fitters in compliance with valid regulations, relevant standards and health and safety codes.

### Transport data

Packaging width	1260 mm
Packaging height	1710 mm
Packaging depth	1470 mm
Gross weight	705 kg

## United Kingdom

Miele Co. Ltd., Fairacres, Marcham Road  
Abingdon, Oxon, OX14 1TW  
Professional Sales, Tel: 0845 365 6608  
E-mail: professional@miele.co.uk  
Internet: www.miele.co.uk/professional

## Australia

Miele Australia Pty. Ltd.  
ACN 005 635 398, ABN 96 005 635 398  
Level 4, 141 Camberwell Road, Hawthorn East, VIC 3123  
Tel: 1300 731 411  
Internet: www.miele.com.au/professional  
E-mail: professional.sales@miele.com.au

## China Mainland

Miele Electrical Appliances Co., Ltd.  
1-3 Floor, No. 82 Shi Men Yi Road  
Jing' an District, 200040 Shanghai, PRC  
Tel: +86 21 6157 3500, Fax: +86 21 6157 3511  
E-mail: info@miele.cn, Internet: www.miele.cn

## Hong Kong, China

Miele (Hong Kong) Ltd.  
41/F - 4101, Manhattan Place  
23 Wang Tai Road, Kowloon Bay, Hong Kong  
Tel: (852) 2610 1025, Fax: (852) 3579 1404  
Email: customerservices@miele.com.hk  
Website: www.miele.hk

## India

Miele India Pvt. Ltd.  
1st Floor, Copia Corporate Suites,  
Commercial Plot 9, Mathura Road, Jasola,  
New Delhi - 110025  
E-mail: customercare@miele.in, Website: www.miele.in

## Ireland

Miele Ireland Ltd.  
2024 Bianconi Ave., Citywest Business Campus,  
Dublin 24  
Tel: (01) 461 07 10, Fax: (01) 461 07 97  
E-Mail: info@miele.ie, Internet: www.miele.ie

## Malaysia

Miele Sdn Bhd  
Suite 12-2, Level 12  
Menara Sapura Kencana Petroleum  
Solaris Dutamas No. 1, Jalan Dutamas 1  
50480 Kuala Lumpur, Malaysia  
Phone: +603-6209-0288  
Fax: +603-6205-3768

## New Zealand

Miele New Zealand Limited  
IRD 98 463 631  
8 College Hill  
Freemans Bay, Auckland 1011, NZ  
Tel: 0800 464 353  
Internet: www.miele.com.au/professional  
E-mail: professional.sales@miele.com.au

## Singapore

Miele Pte. Ltd.  
29 Media Circle, #11-04 ALICE@Mediapolis  
Singapore 138565  
Tel: +65 6735 1191, Fax: +65 6735 1161  
E-Mail: info@miele.com.sg  
Internet: www.miele.sg

## South Africa

Miele (Pty) Ltd  
63 Peter Place, Bryanston 2194  
P.O. Box 69434, Bryanston 2021  
Tel: (011) 875 9000, Fax: (011) 875 9035  
E-mail: info@miele.co.za  
Internet: www.miele.co.za

## United Arab Emirates

Miele Appliances Ltd.  
Showroom 1, Eiffel 1 Building  
Sheikh Zayed Road, Umm Al Sheif  
P.O. Box 114782 - Dubai  
Tel. +971 4 3044 999, Fax. +971 4 3418 852  
800-MIELE (64353)  
E-Mail: info@miele.ae  
Website: www.miele.ae



Manufacturer: Miele & Cie. KG, Carl-Miele-Straße 29, 33332 Gütersloh, Germany