

# Miele

M.-Nr. 12 506 290 / 00

## de - Montageplan für vollintegrierte Geschirrspüler mit FrontFit / Einbau in Küchenzeile

Bitte beachten Sie diesen Montageplan und lesen Sie unbedingt die Gebrauchsanweisung vor der Aufstellung - Installation - Inbetriebnahme.  
Dadurch schützen Sie sich und vermeiden Schäden an Ihrem Gerät.

## en - Installation sheet for fully integrated dishwashers with FrontFit / fitted in a run of units

To avoid the risk of accidents or damage to the dishwasher please observe this installation sheet and read the operating instruction manual supplied with it before it is installed or used for the first time.

## fr - Plan de montage pour lave-vaisselle totalement intégrables avec fonction FrontFit / intégration dans un linéaire de cuisine

Pour votre sécurité et afin d'éviter d'endommager votre appareil, veuillez suivre les indications de cette notice et lire le mode d'emploi avant de monter, d'installer ou de mettre en service votre lave-vaisselle.

## nl - Montageschema voor volledig geïntegreerde vaatwassers met FrontFit/ inbouw in keukenblok

Bekijk dit montageschema en lees de gebruiksaanwijzing voordat u uw apparaat plaatst, installeert en in gebruik neemt.  
Dat is veiliger voor uzelf en u voorkomt daarmee onnodige schade aan uw apparaat.

## it - Schema di montaggio per lavastoviglie a scomparsa totale con FrontFit / incasso in una fila di mobili cucina

Prima di installare e mettere in funzione la lavastoviglie, leggere assolutamente le istruzioni per l'uso e attenersi a questo schema di montaggio per evitare di farsi male o di danneggiare l'elettrodomestico.

## es - Plano de instalación para lavavajillas de integración total con FrontFit / instalación en muebles de cocina

Le agradecemos su confianza y esperamos disfrute de su nuevo aparato.  
Para ello es imprescindible, antes de su emplazamiento, instalación y puesta en marcha, tener en cuenta este esquema de montaje y leer las instrucciones de manejo, para evitar daños tanto al usuario, como al aparato.

## pt - Plano de montagem para máquinas de lavar louça de integrar completamente com FrontFit / montagem em bancada de cozinha

Observe este plano de montagem e leia as instruções de utilização antes de instalar, ligar e iniciar o funcionamento com a máquina.  
Esta forma não só se protege como evita anomalias no seu aparelho.

## tr - FrontFit ve Fonksiyonlu Tam Ankastr Bulaşık Makinesi İçin Montaj Planı/ Mutfak Ünitesine Montaj

Cihazı kurmadan ve ilk kez çalıştırmadan önce bu montaj planını dikkate alınız ve kullanım kılavuzunu mutlaka okuyunuz. Bu şekilde kendinizi korur ve cihaz gelecek zararların önüne geçersiniz.

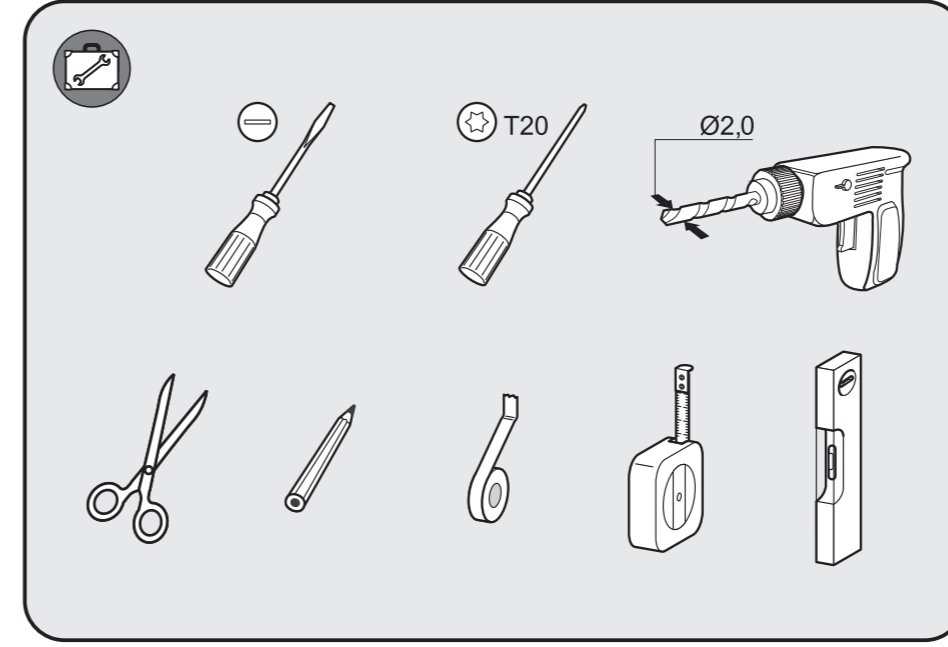
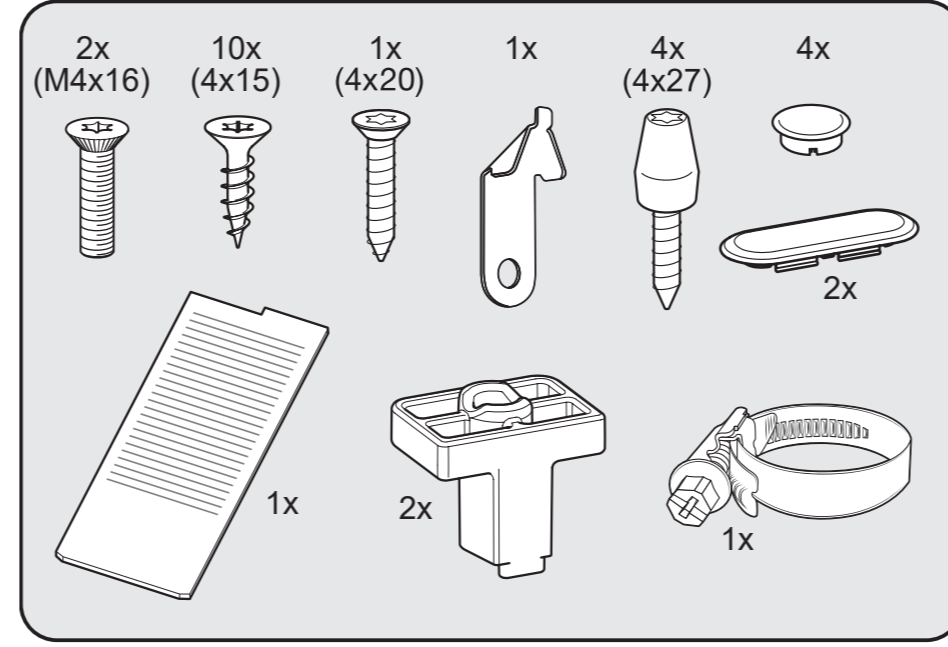
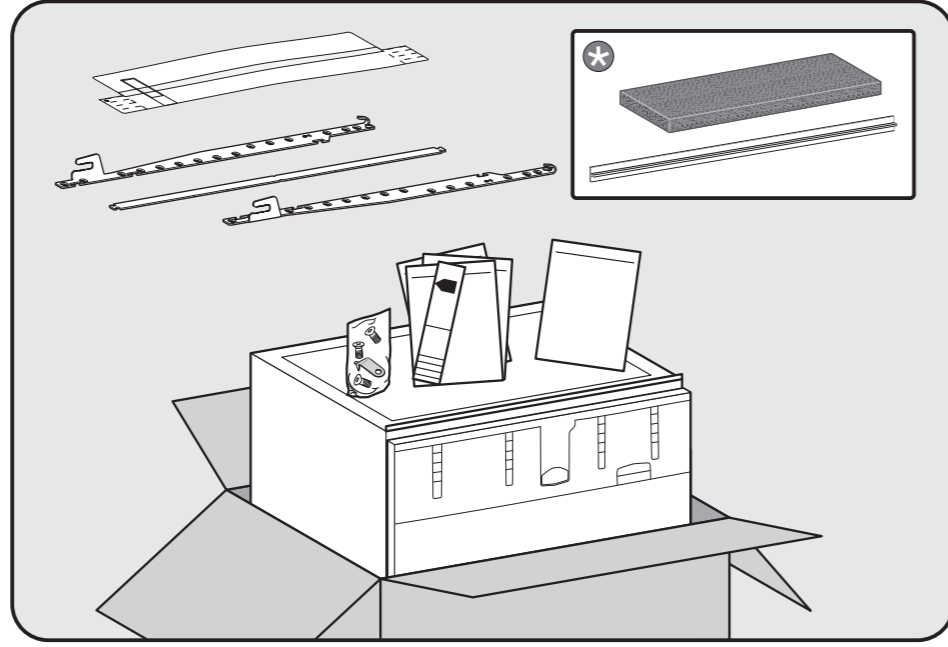

★ Je nach Modell beiliegendes Montagezubehör.  
Fittings supplied depend on model.  
Accessoires fournis selon modèle.  
Voor het desbetreffende model meegeleverde benodigde onderdelen.  
Accessori di montaggio in dotazione, a seconda del modello.  
Según el modelo, accesorios de montaje suministrados.  
De acordo com o modelo, acessórios de montagem fornecidos junto.  
Modelle bağı olarak verilen montaj parçaları.

✎ Je nach Modell benötigtes Werkzeug.  
Tools required depend on model.  
Matériaux requis selon modèle.  
Voor het desbetreffende model benodigd gereedschap.  
Utensili necessari, a seconda del modello.  
Según el modelo, herramienta necesaria.  
De acordo com o modelo, ferramentas necessárias.  
Modelle bağı olarak gerekli aletler.

Funktion FrontFit  
FrontFit function  
Fonction FrontFit

Funcie FrontFit  
Funzione FrontFit  
Función FrontFit

Sistema FrontFit  
FrontFit fonksiyonu

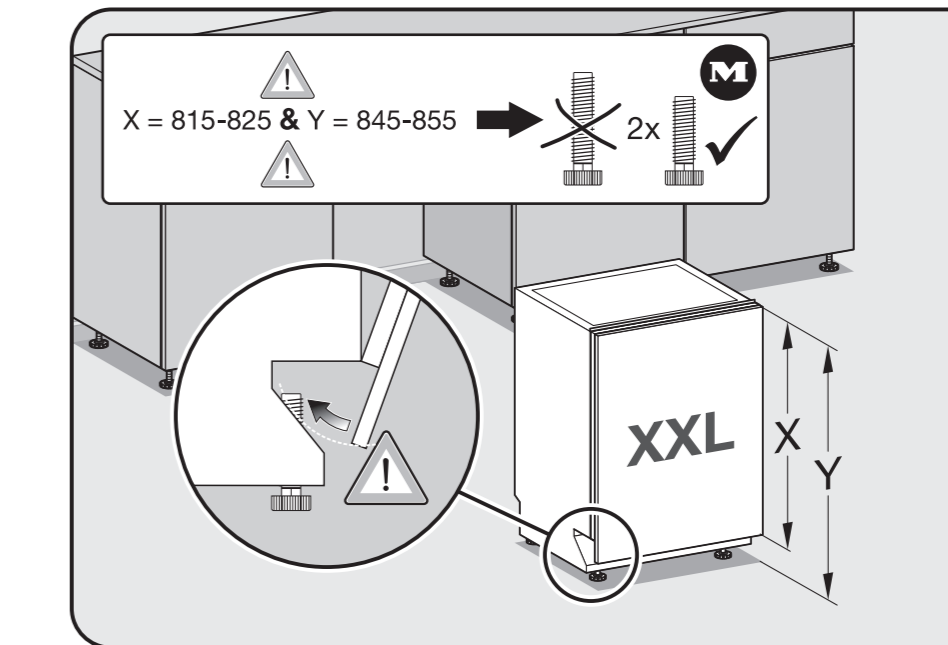
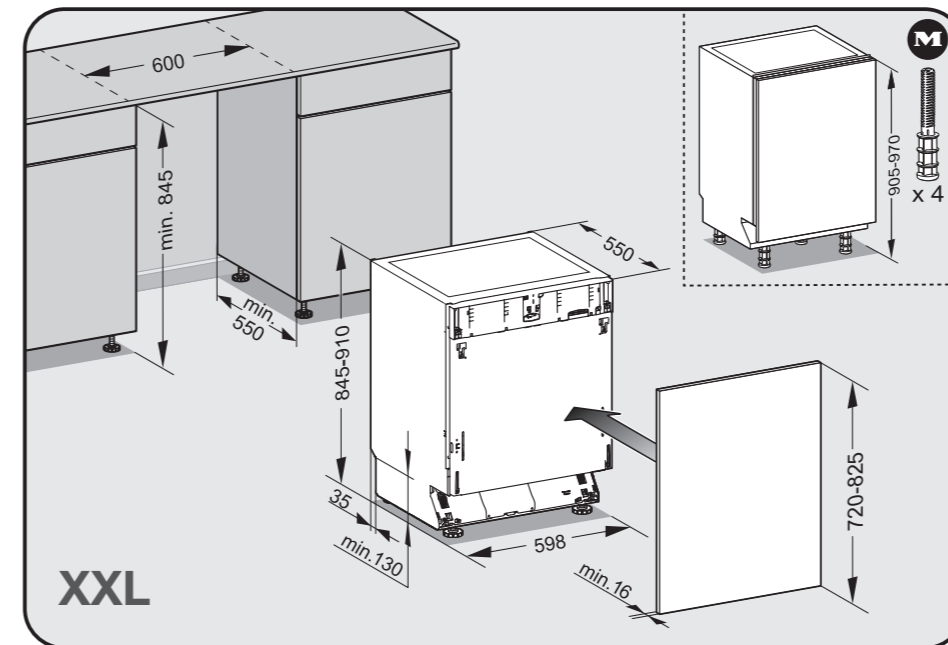
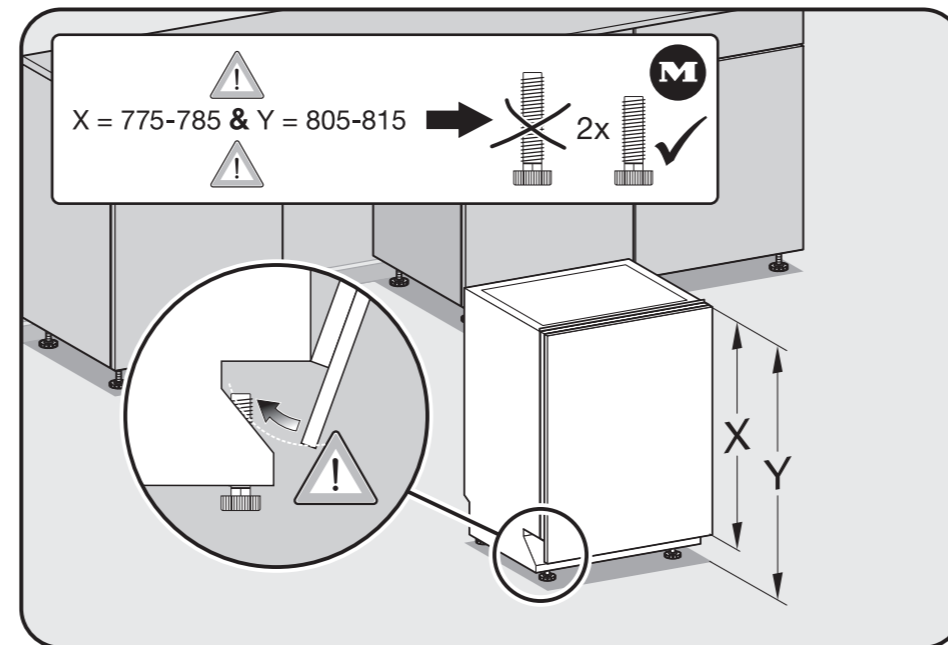
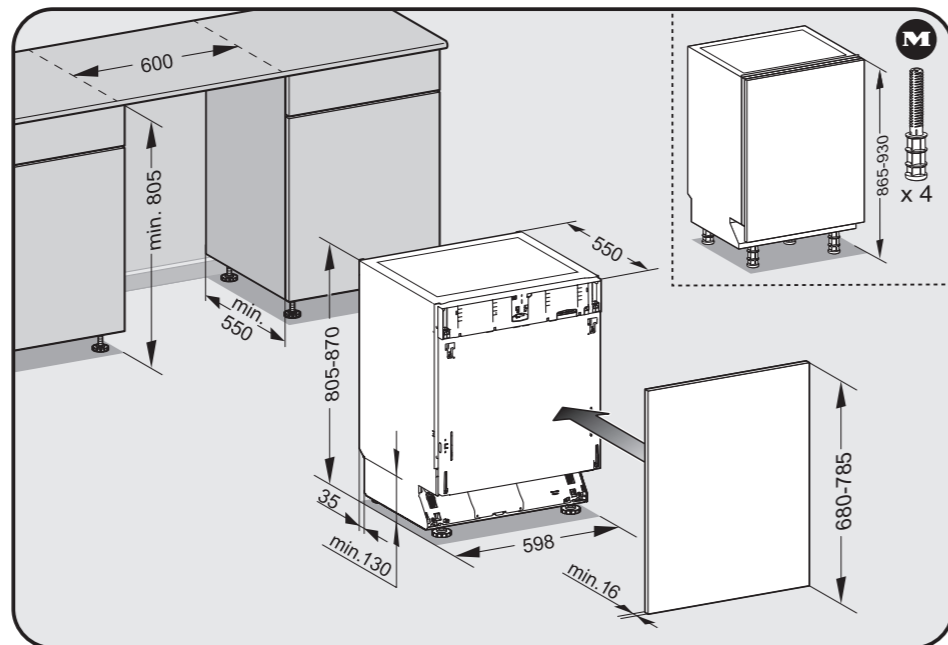
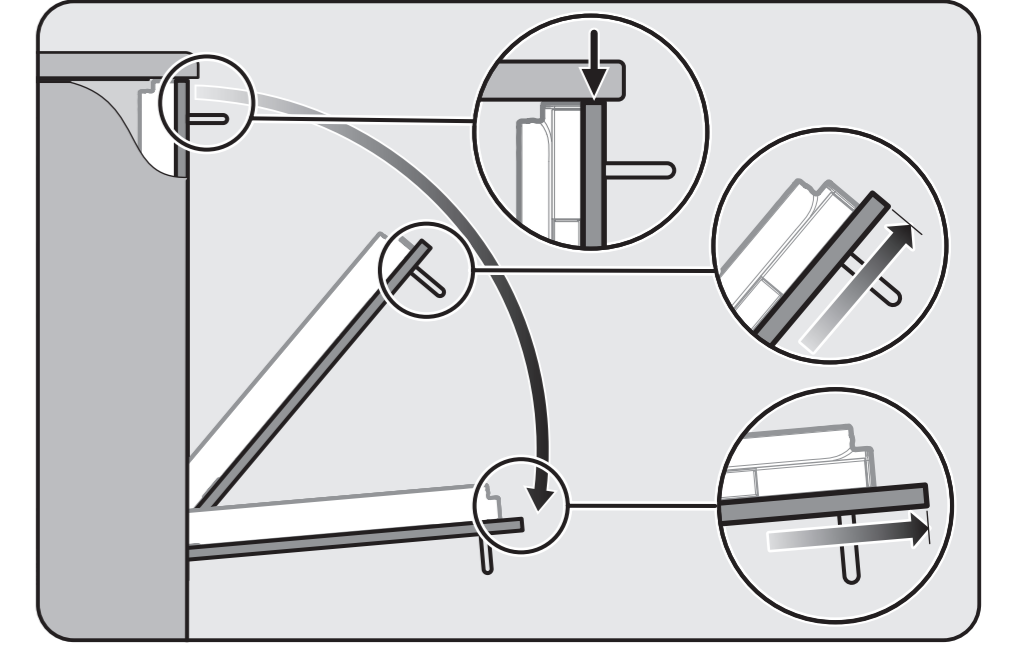

M Nachkaufbares Zubehör  
Optional accessories  
Accessoires en option  
Na te bestellen accessoire  
Accessorio su richiesta  
Accesorio especial  
Acessório que pode adquirir  
Sonradan alınabilen aksesuar

 Gebrauchsanweisung beachten.  
See operating instruction manual.  
Lisez le mode d'emploi.  
Neem de gebruiksaanwijzing in acht.  
Attenersi alle istruzioni d'uso.  
Tenga en cuenta las instrucciones de manejo.  
Observe o indicado no livro de instruções.  
Kullanma kılavuzunu dikkate alınız.

 Beschädigung oder Brandgefahr.  
Risk of damage or fire hazard.  
Risque de dommages ou d'incendie.  
Gevaar voor schade of brand.  
Attenzione: pericolo di danneggiamento o di incendio.  
Daños o riesgo de incendio.  
Risco de avarias ou de incêndio.  
Hasar veya yangın tehlikesi.

 Anschlusswerte beachten.  
Check connection data.  
Respectez les valeurs de raccordement.  
Neem de aansluitwaarden in acht.  
Controllare i valori di allacciamento.  
Aténgase a los valores de conexión.  
Observe os valores para a ligação.  
Bağlantı değerlerine dikkat ediniz.

 Achtung Schnittgefahr.  
Warning: Danger of being cut.  
Attention. Risque de blessure par coupure.  
Pas op. Snijgevaar.  
Attenzione, pericolo di tagliarsi.  
Atención. Peligro de cortes.  
Atenção. Risco de ferimentos por corte.  
Dikkat Kesik Tehlikesi.

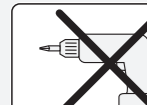
 Keinen Akkuschauber verwenden, Beschädigungsgefahr.  
Do not use a cordless screwdriver, risk of damage.  
N'utilisez pas de visseuse électrique, risque de dommages.  
Gebruik geen accuschroevendraaier. Kans op beschadiging.  
Non utilizzare un avvitatore a batteria, pericolo di danneggiamento.  
No utilizar destornillador automático, peligro de sufrir daños.  
Não usar aparafusadoras sem fios, risco de danos.  
Şarjlı tornavida kullanmayınız, hasar tehlikesi.

 Das minimale/maximale Frontplattengewicht finden Sie unter den Technischen Daten Ihres Geschirrspülers auf der Miele Internetseite.  
The minimum/maximum weight of the front panel is quoted in the technical data for your dishwasher on the Miele website.  
Vous trouverez le poids minimal/maximal du panneau de façade dans les caractéristiques techniques de votre lave-vaisselle sur le site Internet de Miele.  
Het minimale/maximale gewicht van de frontplaat vindt u bij de technische gegevens van uw vaatwasser op de website van Miele.  
Il peso minimo/massimo relativo al pannello frontale è indicato sotto i dati tecnici della lavastoviglie, sul sito internet di Miele.  
El peso mínimo/máximo del panel frontal se puede encontrar en los datos técnicos del lavavajillas en la página web de Miele.  
Pode encontrar o peso mínimo/máximo dos painéis frontais nas características técnicas da sua máquina de lavar louça no site da Miele.  
Minimum/maksimum ön panel ağırlığını, Miele web sitesinde, bulaşık makinenizin teknik verilerinde bulabilirsiniz.

 Türfedern nach Montage der Frontplatte unbedingt auf beiden Seiten gleichmäßig einstellen.  
The door springs must be set equally on both sides after fitting the front panel to the door.  
Les ressorts de porte doivent impérativement être réglés de la même façon des deux côtés après le montage de la plaque d'habillage.  
Het is beslist noodzakelijk dat u de deurveren na de montage van het frontpaneel aan beide kanten gelijkmatig instelt.  
Dopo aver montato il pannello frontale, regolare assolutamente le molle dello sportello su entrambi i lati affinché siano uguali.  
Después del montaje del aparato, ajustar equilibradamente los muelles de la puerta a ambos lados.  
Após montagem do painel frontal, regular as molas da porta uniformemente de ambos os lados.  
Ön kapak takıldiktan sonra kapak yayları her iki tarafta da mutlaka eşit ayarlanmalıdır.

 Wasserablauf belüften  
Wenn der bauseitige Anschluss für den Wasserablauf tiefer liegt als die Führung für die Rollen des Unterkorbes in der Tür, muss der Wasserablauf belüftet werden.  
Venting the water drain  
If the on-site drainage connection is situated lower than the guide path for the lower basket rollers in the open door, the drainage system must be vented.  
Purger la vidange d'eau  
Si le raccord domestique de vidange est placé plus bas que les guides pour les roulettes du panier inférieur dans la porte, la vidange doit être mise à l'air.

**Waterafvoer beluchten**  
Wanneer de waterafvoeraansluiting ter plaatse lager ligt dan de geleiding voor de wieltjes van het onderrek in de deur, moet de waterafvoer worden belucht.  
**Sfiatare lo scarico idrico**  
Se l'allacciamento per lo scarico dell'acqua in loco si trova più in basso rispetto alla guida delle rotelle del cesto inferiore nello sportello, si deve sfiatare lo scarico.  
**Purgado del desagüe**  
Será necesario purgar el desagüe si la conexión del mismo estuviera situada a menor altura que la guía de las ruedas del cesto inferior en la puerta.  
**Ventilar o esgoto da água**  
Se a ligação para o esgoto da água existente no local se situar num nível mais baixo do que a calha onde o cesto inferior desliza, é necessário efetuar a ventilação do esgoto da água.

**Su giderinin havalandırılması**  
Kurulum yerindeki su gideri bağlantısı, kapaktaki alt sepet tekerlekleri kılavuzundan daha alçaktaysa, su çıkışının havalandırılması gerekir.

