

Operating and installation instructions Steam oven

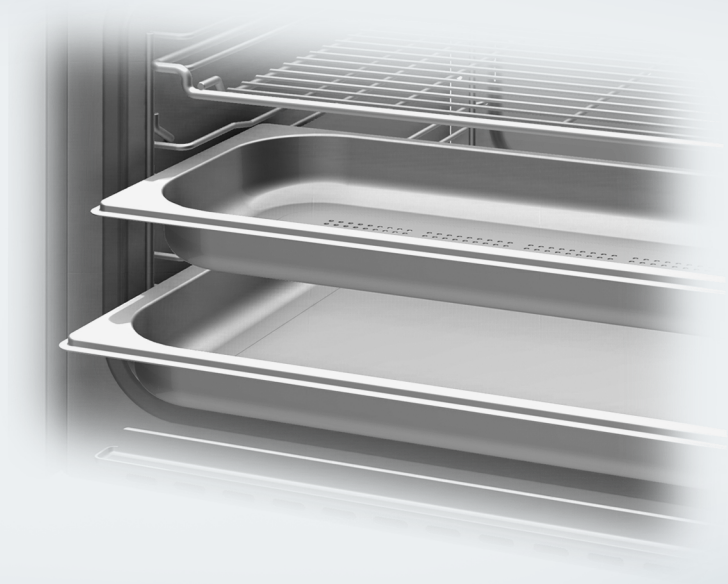

It is **essential** to read these operating and installation instructions before installing and using the appliance. This prevents both personal injury and damage to the appliance.

Contents

| | | | |
|--|-----------|-------------------------------------|-----------|
| Warning and Safety instructions .. | 4 | Shelf level | 26 |
| Sustainability and environmental protection | 10 | Frozen | 26 |
| Familiarising yourself with the appliance..... | 11 | Temperature..... | 26 |
| Steam oven | 11 | Duration..... | 26 |
| Data plate | 12 | Cooking with liquid | 26 |
| Accessories supplied | 12 | Your own recipes | 26 |
| Optional accessories | 12 | Steam cooking..... | 27 |
| Controls | 13 | Eco Steam cooking | 27 |
| Display..... | 14 | Notes on the cooking charts | 27 |
| Sensors | 14 | Vegetables..... | 28 |
| Symbols | 14 | Fish..... | 31 |
| Functional description | 15 | Meat..... | 34 |
| Water container | 15 | Rice | 36 |
| Condensate tray..... | 15 | Grains..... | 37 |
| Temperature..... | 15 | Pasta/Noodles..... | 38 |
| Cooking duration..... | 15 | European dumplings | 39 |
| Noises | 16 | Dried pulses | 40 |
| Heating-up phase | 16 | Hen's eggs | 42 |
| Cooking phase..... | 16 | Fruit | 43 |
| Steam reduction | 16 | Sausages | 43 |
| Commissioning..... | 17 | Shellfish..... | 44 |
| Cleaning for the first time..... | 17 | Mussels | 45 |
| Setting the water hardness..... | 17 | Menu cooking..... | 46 |
| Setting the correct boiling point for water | 17 | Other applications | 47 |
| Settings | 19 | Reheat..... | 47 |
| Operating hours display | 19 | Defrost..... | 49 |
| Changing and saving settings..... | 19 | Blanch | 52 |
| Water hardness..... | 21 | Bottling | 52 |
| Operation | 22 | Disinfect items | 55 |
| Operating the steam oven..... | 22 | Prove yeast dough..... | 55 |
| Changing values for a cooking programme | 23 | Heat damp towels..... | 55 |
| Interrupting a cooking programme .. | 24 | Dissolve gelatine | 55 |
| General notes..... | 25 | Decrystallise honey | 56 |
| The advantages of cooking with steam | 25 | Melt chocolate..... | 56 |
| Suitable containers | 25 | Make yoghurt..... | 57 |
| Condensate tray | 25 | Render fat..... | 58 |
| | | Sweat onions | 58 |
| | | Extracting juice | 58 |
| | | Skinning fruit and vegetables | 59 |
| | | Preserving apples | 59 |
| | | Preparing custard royale | 59 |
| | | Automatic programmes..... | 60 |

| | |
|---|-----------|
| Cleaning and care | 62 |
| Notes on cleaning and care | 62 |
| Unsuitable cleaning agents | 62 |
| Cleaning the front | 63 |
| Cleaning the oven compartment | 63 |
| Cleaning the water container | 63 |
| Cleaning accessories | 63 |
| Cleaning the shelf runners | 64 |
| Descaling the steam oven | 64 |
| Problem solving guide | 66 |
| Messages in the display | 66 |
| Unexpected behaviour | 67 |
| Noises | 67 |
| General problems or technical faults | 68 |
| Service | 69 |
| Contact in case of fault | 69 |
| Warranty | 69 |
| Installation | 70 |
| Safety instructions for installation .. | 70 |
| Installation dimensions | 71 |
| Installation in a tall unit | 71 |
| Installation in a base unit | 72 |
| Side view | 73 |
| Connection and ventilation | 74 |
| Installing the steam oven | 75 |
| Electrical connection | 76 |

Warning and Safety instructions

This appliance complies with all current local and national safety requirements. However, inappropriate use can lead to personal injury and damage to property.

Please read these operating and installation instructions carefully before using the steam oven for the first time. They contain important information on safety, installation, use and maintenance of the appliance. This prevents both personal injury and damage to the steam oven.

In accordance with standard IEC 60335-1, Miele expressly and strongly advises that you read and follow the instructions in “Installation”, as well as in the “Warning and Safety instructions”.

Miele cannot be held liable for injury or damage caused by non-compliance with these instructions.

Keep these instructions in a safe place and pass them on to any future owner.

Correct application

- ▶ This steam oven is designed for domestic use and for use in similar environments by guests in hotel or motel rooms, bed & breakfasts and other typical living quarters. This does not include common/shared facilities or commercial facilities within hotels, motels or bed & breakfasts.
- ▶ The steam oven is not suitable for outdoor use.
- ▶ The steam oven is intended only to steam, defrost and reheat food. Any other use is not permitted.
- ▶ This appliance is not intended for use by persons (including children) with reduced physical, sensory or mental capabilities, or lack of experience and knowledge, unless they have been given supervision or instruction concerning its use by a person responsible for their safety, and are able to recognise the dangers of misuse.

Safety with children

- ▶ Young children must not be allowed to use this appliance.
- ▶ Older children may only use the appliance if its operation has been clearly explained to them and they are able to use it safely. They must be able to understand and recognise the possible dangers caused by incorrect operation.
- ▶ Cleaning may only be carried out by older children under the supervision of an adult.
- ▶ Please supervise children in the vicinity of the steam oven and do not let them play with it.
- ▶ Risk of suffocation from packaging material. Whilst playing, children may become entangled in packaging material (such as plastic wrapping) or pull it over their head with the risk of suffocation. Keep packaging material away from children.
- ▶ Risk of injury caused by hot surfaces and steam. Children's skin is far more sensitive to high temperatures than that of adults. During operation, steam will escape out of the ventilation outlet. The door glass and control panel of the steam oven heat up. Do not let children touch the steam oven when it is in operation. Keep children well away from the steam oven until it has cooled down and there is no danger of injury.
- ▶ Risk of injury from the open door. The oven door can support a maximum weight of 8 kg. Children could injure themselves on an open door. Do not let children sit on the open door, lean against it or swing on it.

Technical safety

- ▶ Installation, maintenance or repairs by unqualified persons could be extremely dangerous. The manufacturer cannot accept liability for unauthorised work. Installation, maintenance and repairs must only be carried out by a qualified specialist or Miele Customer Service.
- ▶ A damaged appliance is dangerous. Check the appliance for any visible damage. Never install or attempt to use a damaged appliance.

Warning and Safety instructions

▶ Temporary or permanent operation with a self-sufficient or non-mains synchronous energy supply system (e.g. isolated networks, back-up systems) is possible. A requirement for the operation is that the energy supply system complies with all current local and national requirements that apply to stand-alone, solar and/or battery systems. The protective measures provided in the installation and in this Miele product must also be assured in their function and operation in isolated operation or in non-mains synchronous operation, or replaced with equivalent measures in the installation.

▶ The electrical safety of this appliance can only be guaranteed when continuity is complete between it and an effective earthing system. It is most important that this basic safety requirement is present and tested regularly and, where there is any doubt, the household wiring system should be inspected by a qualified electrician.

▶ Before connecting the appliance to the mains supply, ensure that the connection data on the data plate (voltage and frequency) matches the mains electricity supply. This data must correspond in order to avoid the risk of damage to the appliance. Consult a qualified electrician if in any doubt.

▶ Do not connect the appliance to the mains electricity supply by a multi-socket adapter or an extension lead. These do not guarantee the required safety of the appliance (e.g. danger of overheating).

▶ For safety reasons, this appliance may only be used after it has been built in.

▶ This appliance must not be installed and operated in mobile installations (e.g. on a ship).

▶ Risk of injury due to electric shock. Any contact with live connections or tampering with the electrical or mechanical components of the oven will endanger your safety and may lead to steam oven malfunctions.

Do not open the steam oven housing under any circumstances.

▶ The manufacturer's warranty will be invalidated if the steam oven is not repaired by a qualified specialist or Miele Customer Service.

▶ We recommend replacing faulty components with original Miele parts. If original Miele parts are installed correctly, Miele guarantees full compliance with safety requirements and the warranty remains valid.

Warning and Safety instructions

- ▶ If the mains plug is removed from the power supply cord or if the power supply cord is supplied without a mains plug, the steam oven must be connected to the mains power supply by a qualified specialist or Miele Customer Service.
- ▶ If the power supply cord is damaged, it must be replaced with a special power supply cord.
- ▶ During installation, maintenance and repair work, the appliance must be disconnected from the mains electricity supply. It is only completely isolated from the electricity supply when:
 - it is switched off at the mains circuit breaker, or
 - it is switched off at the wall socket and the plug is withdrawn from the socket. Do not pull the mains connection cable but the mains plug to disconnect your appliance from the mains electricity supply.
- ▶ If the steam oven is installed behind a furniture front (e.g. a door), do not close the furniture front while the steam oven is in use. Heat and moisture can build up behind a closed furniture door. This can result in damage to the steam oven, the housing unit and the floor. Leave the furniture door open until the steam oven has cooled down completely.
- ▶ In areas which may be subject to infestation by cockroaches or other vermin, pay particular attention to keeping the appliance and its surroundings clean at all times. Any damage caused by cockroaches or other vermin will not be covered by the warranty.

Correct use

- ▶ Risk of injury caused by hot surfaces and steam. The steam oven gets hot during operation. You could burn yourself on the oven compartment, shelf runners, accessories, food or steam. Wear oven gloves when placing food in the oven or removing it, and when adjusting oven shelves etc. in a hot oven.
- ▶ Risk of injury caused by hot food. Food may spill or splash around when placing it into the oven or removing it. The food can cause burns. When placing cooking containers in the oven or removing them, make sure that the hot food does not spill.

Warning and Safety instructions

- ▶ Risk of injury due to hot water.

At the end of a cooking programme, hot water left in the steam generator is pumped back into the water container. Take care not to tip the water container when taking it out of the appliance.

- ▶ Do not use the steam oven to heat up or bottle food in sealed tins. Pressure will build up inside them and they can explode causing damage to the appliance, as well as the risk of injury and scalding.

- ▶ Plastic dishes which are not heat-resistant and steam-resistant melt at high temperatures and can damage the appliance.

Use only heat-resistant (to 100 °C) and steam-resistant plastic dishes. Follow the manufacturer's instructions.

- ▶ Food which is left in the oven compartment can dry out and the moisture released can lead to corrosion damage in the steam oven. Do not leave food in the oven compartment and do not use any cooking containers which are susceptible to corrosion.

- ▶ Risk of injury from the open door. You could bang into the open door or trip over it. Avoid leaving the door open unnecessarily.

- ▶ The door can support a maximum load of 8 kg. Do not sit on or lean against an open door, and do not place heavy objects on it. Also make sure that nothing can get trapped between the door and the oven compartment. The steam oven could get damaged.

- ▶ When using a small electrical appliance, e.g. a hand-held blender, near the steam oven, care should be taken that the cable of the appliance cannot get trapped by the steam oven door. The insulation on the cable could become damaged, giving rise to an electric shock hazard.

Cleaning and care

- ▶ Risk of injury due to electric shock. The steam from a steam cleaning appliance could reach electrical components and cause a short circuit. Never use a steam cleaner for cleaning.

- ▶ Scratches on the door glass can result in the glass breaking.

Do not use abrasive cleaners, hard sponges, brushes or sharp metal tools to clean the door glass.

- ▶ The shelf runners can be removed. Refit the shelf runners correctly.

- ▶ Try to avoid the interior walls being splashed with food or liquids containing salt. If it does happen, wipe these away thoroughly to avoid corrosion on the stainless steel surface.

Accessories

- ▶ We recommend using original Miele accessories. Using spare parts or accessories from other manufacturers will invalidate the warranty and Miele cannot accept liability.
- ▶ Miele original spare parts are kept in stock for at least 10 years and up to 15 years after discontinuation of your steam oven.

Sustainability and environmental protection

Disposal of the packing material

The transport and protective packaging has been selected from materials which are environmentally friendly for disposal, and can normally be recycled.

Recycling the packaging reduces the use of raw materials in the manufacturing process and also reduces the amount of waste in landfill sites.

Ensure that any plastic wrappings, bags etc. are disposed of safely and kept out of the reach of babies and young children. Danger of suffocation.

Only for Australia: Note for installer: Expanded polystyrene (EPS) packaging included. Please retain and dispose of EPS packaging responsibly. For further information, please contact Miele.

Disposing of your old appliance

Electrical and electronic appliances often contain valuable materials. They also contain specific materials, compounds and components, which were essential for their correct function and safety. These could be hazardous to human health and to the environment if disposed of with your domestic waste or if handled incorrectly. Please do not, therefore, dispose of your old appliance with your household waste.



Please dispose of it at your local community waste collection / recycling centre for electrical and electronic appliances. You are also responsible for deleting any personal data that may be stored on the appliance prior to disposal. Please ensure that your old appliance poses no risk to children while being stored prior to disposal.

Familiarising yourself with the appliance

Steam oven

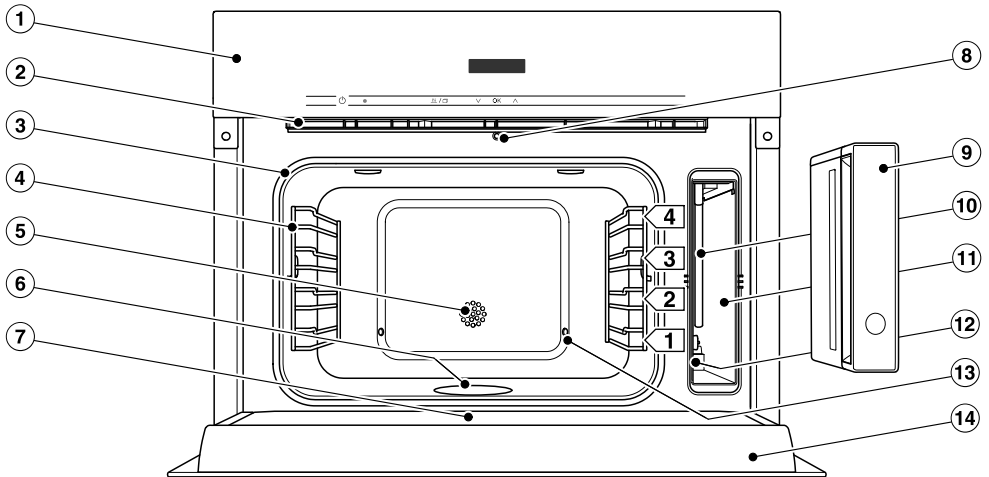

- ① Control panel
- ② Ventilation outlet
- ③ Door seal
- ④ Shelf runners with 4 shelf levels
- ⑤ Temperature sensor
- ⑥ Floor heating element
- ⑦ Drip channel
- ⑧ Automatic door release for steam reduction
- ⑨ Water container with removable spill guard
- ⑩ Suction tube
- ⑪ Compartment for water container
- ⑫ Data plate
- ⑬ Steam outlet
- ⑭ Door

Familiarising yourself with the appliance

A list of the models described in these operating and installation instructions can be found on the back page.

Data plate

The data plate is located inside the compartment for the water container. The data plate states the model number, the serial number as well as connection data (mains voltage, frequency and maximum rated load).

The model number and serial number (SN) can also be found on the small data plate, which can be seen on the front frame when the door is open.

Have this information available if you need to contact Miele so that any issues can be rectified as quickly as possible.

Accessories supplied

The accessories supplied with your appliance, as well as a range of optional ones, are available to order from Miele (see "Optional accessories").

Further accessories may be included depending on the country and model in question.

DGG 100-40 condensate tray

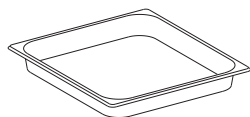

1 stainless steel condensate tray for collecting excess moisture. You can also use the condensate tray as a cooking container.
375 x 394 x 40 mm (W x D x H)

DGG 50-40 steam oven container

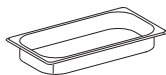

1 solid stainless steel steam oven container
Gross capacity 2.2 l /
Usable capacity 1.6 l
375 x 197 x 40 mm (W x D x H)

DGGL 50-40 steam oven container

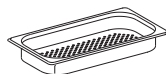

2 perforated stainless steel steam oven containers
Gross capacity 2.2 l /
Usable capacity 1.6 l
375 x 197 x 40 mm (W x D x H)

Rack



1 rack for placing your own cooking containers on

Descaling tablets

For descaling the appliance.

Optional accessories

Products specially tailored to your steam oven – such as care products and accessories – are available from the Miele online shop or from Miele Customer Service.



You can access the Miele online shop via the following QR code:

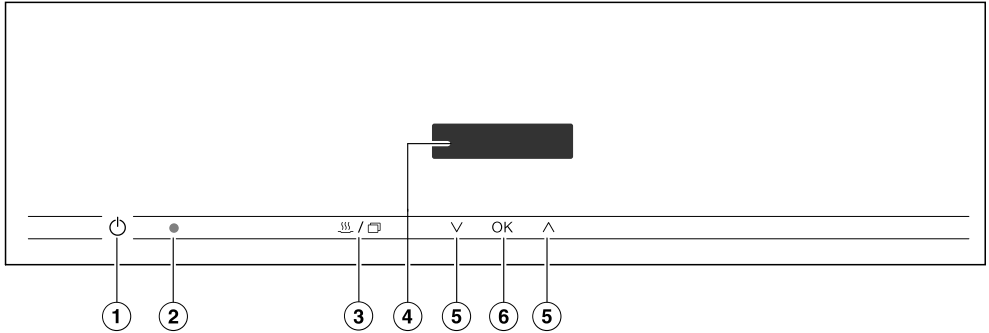

Familiarising yourself with the appliance

Controls



- ① Recessed On/Off  sensor
For switching the steam oven on and off
- ② Optical interface
(for Miele service technicians only)
- ③  /  sensor
For alternating between steam cooking, *ECD* steam cooking and Automatic programmes
- ④ Display
For displaying operational information
- ⑤ ∇ / \blacktriangle sensors
For changing values and settings and scrolling through lists
- ⑥ *OK* sensor
For confirming entries and selecting and saving settings

Familiarising yourself with the appliance

Display



The display is used to show information about temperatures, cooking durations, Automatic programmes and settings.

Sensors

The sensors react to touch. Each touch is confirmed with a keypad tone. This keypad tone can be switched off (see “Settings – Keypad tone”).

Symbols

The following symbols and indicators may appear in the display during operation:

| Symbol/Indicator | Meaning |
|--|--|
|  | Steam cooking |
|  (flashes) | Insufficient water or water container not present |
| <i>ECO</i> | <i>ECO</i> steam cooking |
| Auto <i>R</i> + number(s) | Automatic programme |
| Numbers + °C | Temperature |
| Numbers + h | Cooking duration |
|  + number(s) | The steam oven needs to be descaled (see “Cleaning and care – Descaling the steam oven”) |

Familiarising yourself with the appliance

Functional description

Water container

The maximum filling volume is 1.5 litres and the minimum is 1.0 litre. There are markings on the water container. The upper marking must never be exceeded.

Water consumption depends on the type of food and the cooking duration. The water may need to be topped up during cooking. Water consumption is increased if the door is opened during cooking.

The water container is removed using a push/pull system: push gently on the water container to remove it.

At the end of a cooking programme, hot water left in the steam generator is pumped back into the water container. The water container must be emptied after each use involving steam.

Condensate tray

Place the condensate tray on shelf level 1 when using perforated containers. This collects any drops of liquid and allows these to be removed easily.

You can also use the condensate tray as a cooking container if necessary.

Temperature

The steam oven has a temperature range of 40 °C to 100 °C. The appliance is set at 100 °C when it is switched on. You can alter the temperature in 5 °C steps.

Recommended temperatures

| Temperature | Use |
|-------------|--|
| 100 °C | <ul style="list-style-type: none">- Cooking all types of food- Reheating- Menu cooking- Bottling- Extracting juice |
| 85 °C | <ul style="list-style-type: none">- Cooking fish gently |
| 50–60 °C | <ul style="list-style-type: none">- Defrosting |
| 40 °C | <ul style="list-style-type: none">- Proving yeast dough- Making yoghurt |

Cooking duration

A cooking duration of between 1 minute (0:01) and 9 hours 59 minutes (9:59) can be set. If the cooking duration exceeds 59 minutes, you have to enter it in hours and minutes.

Example: Cooking duration 80 minutes = 1:20.

Familiarising yourself with the appliance

Noises

You will hear a pumping sound when the appliance is switched on, during use and after switching it off. This is the sound of water being pumped through the system and is quite normal.

When the steam oven is in use, you will hear a fan noise.

Heating-up phase

During the heating-up phase the oven compartment is heated to the set temperature. The display shows the temperature in the oven compartment as it rises.

The duration of the heating-up phase will depend on the quantity and temperature of the food. In general, the heating-up phase will take approx. 7 minutes. The duration will be longer if you are cooking refrigerated or frozen food and if you are cooking at low temperatures.

Cooking phase

The cooking phase begins when the set temperature is reached. During the cooking phase, the duration remaining will be shown in the display.

Steam reduction

If a cooking temperature above approx. 80 °C has been set, the appliance door will automatically open a fraction just before the end of a cooking programme to release some of the steam from the cabinet. The door will then close again automatically.

Steam reduction can be switched off if you wish (see “Settings”). If switched off, there will be a lot of steam emitted from the cabinet when the door is opened.

 Risk of injury caused by hot surfaces.

The steam oven gets hot during operation.

For safety reasons, the steam oven may only be used when it has been fully installed.

The steam oven will switch on automatically when it is connected to the electricity supply.

Cleaning for the first time

- Remove any protective foil and stickers, except the data plate, from the oven and accessories.

The appliance has undergone a function test in the factory. Residual water from this testing may have trickled back into the cabinet during transportation.

Cleaning the water container

- Remove the water container.
- Remove the spill guard.
- Rinse the water container by hand.

Cleaning the accessories/oven compartment

- Take all accessories out of the oven compartment.
- Wash the accessories in a mild solution of washing-up liquid and hot water or in the dishwasher.

The interior of the steam oven has been treated at the factory with a conditioning agent.

- To remove this, clean the oven interior with a mild solution of washing-up liquid and warm water applied with a soft sponge, and then dry thoroughly with a soft cloth.

Setting the water hardness

To ensure that the steam oven works correctly and to ensure that descaling is carried out at the correct interval, it must be set to the local water hardness level.

The harder the water is, the more frequently the steam oven needs to be descaled.

The hardness level is set to 3.8 mmol/l (21 °dH) at the factory.

Contact your local water supplier to find out your local water hardness range if necessary.

- Set your local water hardness (see “Settings – Changing and saving settings”).

Setting the correct boiling point for water

Before cooking food for the first time, you must adjust the steam oven to the boiling temperature of the water, which varies depending on the altitude of where the steam oven is located. This procedure also flushes out the waterways.

This procedure **must** be carried out to ensure efficient functioning of your appliance.

Distilled or carbonated water or other liquids could damage the steam oven.
Only use cold, fresh drinking water (below 20 °C).

Commissioning

- Remove the water container and fill it up to the top marker.
- Push the water container into the appliance.
- Run the steam oven for 15 minutes using the steam cooking  function (100 °C). Proceed as described in “Operation”.





Setting the correct boiling point for water following a house move

If you move house, the boiling point for the water in the steam oven will need to be reset for the new altitude if this differs from the old one by 300 m or more. To do this, descale the appliance (see “Cleaning and care – Descaling the steam oven”).

Operating hours display

You can query the total number of operating hours of your steam oven.

With the steam oven **switched off**:



- Touch and hold the  /  sensor.
- Whilst holding the  /  sensor, touch the On/Off  sensor once briefly.

The operating hours will appear.



Changing and saving settings

Your steam oven is supplied with a number of standard default settings. The standard settings listed in the chart below can be altered.



With the steam oven **switched off**:

- Touch and hold the  sensor.
- Whilst holding the  sensor, touch the On/Off  sensor once briefly.

P1 will appear.

- Touch the  or  sensor to set the required programme.
- Confirm with *OK*.

S and a number will appear.

- Touch the  or  sensor to set the required status/water hardness.
- Confirm with *OK*.

The selected status will be saved.

- After you have altered the setting(s) required, switch the appliance off.

Settings

The factory default setting is shown in **bold**.

| Programme | | Water hardness/ Status | Available settings |
|-----------|------------------|-----------------------------|--|
| P1 | Water hardness | 21° | See “Settings – Water hardness” |
| P2 | Buzzer volume | S1 S2 S3 S4 | Very quiet Quiet Loud Very loud |
| P3 | Keypad tone | S0 S1 | Off On |
| P4 | Steam reduction | S0 S1 | Off On |
| P5 | Temperature unit | S1 S2 | °C °F |
| P6 | Demo mode | S0 S1 | Off, the steam oven heats up On, the steam oven does not heat up |

Water hardness

Contact your local water supplier to find out your local water hardness range if necessary.

The degree of hardness can be set between 0.2 mmol/l and 12.5 mmol/l (1 °dH and 70 °dH).

If you are using bottled drinking water, e.g. mineral water, use non-carbonated water. Select settings according to the calcium content. The calcium content is given on the label of the bottle in mg/l Ca²⁺ or ppm (mg Ca²⁺/l).

| Water hardness | | Calcium content mg/l Ca ²⁺ or ppm (mg Ca ²⁺ /l) | Setting |
|----------------|--------|---|---------|
| °dH | mmol/l | | |
| 1 | 0.2 | 7 | 1° |
| 2 | 0.4 | 14 | 2° |
| 3 | 0.5 | 21 | 3° |
| 4 | 0.7 | 29 | 4° |
| 5 | 0.9 | 36 | 5° |
| 6 | 1.1 | 43 | 6° |
| 7 | 1.3 | 50 | 7° |
| 8 | 1.4 | 57 | 8° |
| 9 | 1.6 | 64 | 9° |
| 10 | 1.9 | 71 | 10° |
| 11 | 2.0 | 79 | 11° |
| 12 | 2.2 | 86 | 12° |
| 13 | 2.3 | 93 | 13° |
| 14 | 2.5 | 100 | 14° |
| 15 | 2.7 | 107 | 15° |
| 16 | 2.9 | 114 | 16° |
| 17 | 3.1 | 121 | 17° |
| 18 | 3.2 | 129 | 18° |
| 19 | 3.4 | 136 | 19° |
| 20 | 3.6 | 143 | 20° |

| Water hardness | | Calcium content mg/l Ca ²⁺ or ppm (mg Ca ²⁺ /l) | Setting |
|----------------|-----------|---|---------|
| °dH | mmol/l | | |
| 21 | 3.8 | 150 | 21° |
| 22 | 4.0 | 157 | 22° |
| 23 | 4.1 | 164 | 23° |
| 24 | 4.3 | 171 | 24° |
| 25 | 4.5 | 179 | 25° |
| 26 | 4.7 | 186 | 26° |
| 27 | 4.9 | 193 | 27° |
| 28 | 5.0 | 200 | 28° |
| 29 | 5.2 | 207 | 29° |
| 30 | 5.4 | 214 | 30° |
| 31 | 5.6 | 221 | 31° |
| 32 | 5.8 | 229 | 32° |
| 33 | 5.9 | 236 | 33° |
| 34 | 6.1 | 243 | 34° |
| 35 | 6.3 | 250 | 35° |
| 36 | 6.5 | 257 | 36° |
| 37-45 | 6.6-8.0 | 258-321 | 37°-45° |
| 46-60 | 8.2-10.7 | 322-429 | 46°-60° |
| 61-70 | 10.9-12.5 | 430-500 | 61°-70° |

Operation

Operating the steam oven

Distilled or carbonated water or other liquids could damage the steam oven.

Only use cold, fresh tap water (below 20 °C).

- Fill the water container with fresh tap water and push it into the appliance.
- Place the condensate tray on shelf level 1 when using perforated containers.
- Place the food in the oven.
- Switch the steam oven on.



☹☹☹ 100 °C will appear. 100 flashes.

- If you want to cook with 100 °C, confirm the setting with *OK*.
- If you wish, you can set a lower temperature by touching the ∨ sensor. Then confirm with *OK*.

This temperature will be automatically accepted within a few seconds. Touch *OK* twice to go back to the temperature selection option.



☹☹☹ 0:00 h will appear.

The 0 symbol for the hours will flash.

- If you want to set a cooking duration of
 - less than 1 hour, confirm with *OK*,
 - more than 1 hour, set the cooking duration you want by touching the ^ sensor (from 0 upwards) or ∨ (from 9 downwards) and confirm with *OK*.
- Set the minutes you want by touching the ^ sensor (from 00 upwards) or ∨ (from 59 downwards).
- Confirm with *OK*.

The current temperature will appear and the heating-up phase will begin.

You will see the temperature rising in the display. A buzzer will sound when the selected temperature is reached for the first time.

The cooking duration will begin to count down.

If you are cooking at a temperature of approx. 80 °C, shortly before the end of the cooking duration, the door will automatically open a little to allow some of the steam to escape from the oven compartment. The door will then automatically close.

The buzzer will sound at the end of the cooking duration.

- Take the food out of the oven.
- Switch the steam oven off.

A new cooking programme can only be started if the automatic door release is retracted into its original position. Do not push it in manually as this could damage it.

Cleaning the steam oven

- If necessary, remove the condensate tray from the oven compartment and empty it.

 Risk of injury due to hot water.
At the end of a cooking programme, hot water left in the steam generator is pumped back into the water container.
Take care not to tip the water container when taking it out of the appliance.

- Remove the water container.
- Remove the spill guard and empty the water container.
- After each use, clean and dry the whole appliance as described in “Cleaning and care”.

Make sure the spill guard engages correctly when installing it.

- Leave the appliance door open until the oven interior is completely dry.

Refilling the water

Insufficient water during a cooking programme is indicated by the flashing  symbol and a buzzer.

- Remove the water container and fill it with fresh tap water.
- Push the water container back into the appliance.

The cooking programme will continue.

Changing values for a cooking programme

As soon as a cooking programme is in progress, you can change the temperature and cooking duration for this programme.

Changing the temperature

- Touch *OK* once.

The display will change to the temperature setting and the temperature will flash.

- Touch the ∇ or \wedge sensor to change the temperature.
- Confirm with *OK*.

Changing the cooking duration

- Touch *OK* twice.

The display will change to setting the cooking duration and the number for the hours will flash.

- Touch the ∇ or \wedge sensor to change the cooking duration.
- Confirm with *OK*.

Operation

Interrupting a cooking programme

A cooking programme is interrupted as soon as the door is opened. The oven heating switches off. Set cooking durations will be saved.



Risk of injury due to hot steam.

A great deal of hot steam can escape when the door is opened. The steam can cause burns.

Step back and wait until the hot steam has dissipated.



Risk of injury caused by hot surfaces and food.

The steam oven gets hot during operation. You could burn yourself on the oven compartment, shelf runners, accessories or the food itself.

Wear oven gloves when placing food in the oven or removing it and when adjusting oven shelves etc. in a hot oven.

When placing cooking containers in the oven or removing them, make sure that the hot food does not spill.

The cooking programme will resume when the door is closed.

When the door is closed, the pressure has to equalise, which can cause a whistling sound.

The steam oven will heat up again and the display will show the temperature in the cooking compartment as it rises. Once the set temperature has been reached, the display will show the time left as it counts down.

The cooking process will be ended early if the door is opened in the last minute of cooking time.

This section contains general information. You will find more detailed information about particular foods and how to cook them in the other sections.

The advantages of cooking with steam

Almost all vitamins and minerals are retained as the food is not immersed in water.

Cooking with steam also retains the true taste of the food better than conventional cooking. We therefore recommend seasoning the food after it has been cooked. Food also retains its fresh, original colour.

Suitable containers

Cooking containers

This steam oven is supplied with stainless steel cooking containers. Other containers, in a variety of sizes, both perforated and solid, are available as optional extras (see “Optional accessories”). This enables you to choose the most suitable container for the food you are preparing.

Where possible, it is best to use perforated cooking containers for steam cooking. The steam can reach the food from all sides and the food is cooked evenly.

Your own containers

You can also use your own containers. However, please note the following:

- Containers must be heat-resistant to 100 °C and able to withstand steam. With plastic containers, please check with the manufacturer that they are suitable for use in a steam oven.
- Thick-sided containers made from porcelain, ceramic, or stoneware are not very suitable for using with steam. Due to their thick sides, they do not conduct heat well and as a result cooking durations will be considerably longer than those given in the charts.
- Place the cooking container on the rack or in a suitable container, and not on the oven floor.
- Ensure that there is a gap between the upper rim of the container and the top of the cooking compartment to allow sufficient steam into the container.

Condensate tray

Place the condensate tray on shelf level 1 when using perforated containers.

This collects any drops of liquid and allows these to be removed easily.

You can also use the condensate tray as a cooking container if necessary.

General notes

Shelf level

You can select any shelf level. You can also cook on several levels at the same time. This will not alter the cooking duration.

When using more than one deep container at the same time for steam cooking, it is best to offset them on their runners and to leave at least one level free in between them.

Always insert cooking containers and the rack between the rails of the shelf runners so that they cannot tip.

The rack has a rail at the front and at the back to prevent dishes sliding off. Ensure the rack is inserted so that the rails are facing upwards.

Frozen

The heating-up phase for frozen food is longer than for fresh food. The greater the quantity of frozen food, the longer the heating-up phase.

Temperature

During steam cooking, the temperature does not exceed 100 °C. Almost all foods can be cooked at this temperature. Some types of food, such as berries, need to be cooked at lower temperatures to prevent them from bursting. See the relevant sections in these operating instructions for more details.

Duration

During steam cooking, the cooking duration does not begin until the set temperature is reached.

In general, the cooking durations for cooking with steam are the same as for cooking food in a saucepan. More information about any factors which may affect the cooking duration is given in the relevant sections.

The quantity of food does not affect the cooking duration. 1 kg of potatoes will take the same time to cook as 500 g of potatoes.

Cooking with liquid

When cooking with liquid, only fill the cooking container $\frac{2}{3}$ full to prevent the liquid spilling when the cooking container is removed from the oven.

Your own recipes



Food which is cooked in a pot or a pan can also be cooked in the steam oven. The cooking durations in the steam oven will be the same. Please note that food will not be brown or crisp when cooking with steam.

Eco Steam cooking

To save energy when cooking with steam, you can use Eco Steam cooking. Eco Steam cooking is particularly suitable for cooking vegetables and fish. Eco Steam cooking is less suitable for cooking foods containing starch, such as potatoes, rice and pasta.

We recommend using the cooking durations and temperatures given in the chart under “Steam cooking”.

You can cook for longer if necessary.

- Switch the steam oven on.
- Touch the  /  sensor.

ECD will appear in the display.

- Confirm with *OK*.
- Set the temperature and cooking duration.

Notes on the cooking charts

Follow the instructions on cooking durations, temperatures and cooking notes.

Selecting the cooking duration

The cooking durations given are guidelines only.

- We recommend selecting the shorter duration initially. You can cook for longer if necessary.

Steam cooking

Vegetables

Fresh

Prepare fresh vegetables in the usual way, i.e. wash, clean and cut them up.

Frozen food

Frozen vegetables do not need to be defrosted beforehand. Exception: the vegetables have been frozen together in a block.

Frozen and fresh vegetables which take the same length of time to cook can be cooked together.

If vegetables have frozen together in clumps, break these up before cooking with steam. Follow the manufacturer's instructions on the packaging regarding cooking duration.

Cooking containers

Food such as peas or asparagus spears, which have little or no space between them, will take longer to cook because the steam has less space to work in. For an even result, it is best to use a shallow container for these types of food, and only fill it about 3 - 5 cm deep. When cooking large quantities, divide the food between 2 or 3 shallow containers rather than using one deep one.

Different types of vegetables which take the same length of time to cook can be cooked together in one cooking container.

Use solid containers for vegetables which are cooked in liquid, e.g. cabbage.

Shelf level

When cooking vegetables with a distinctive colour (e.g. beetroot) in a perforated container at the same time as cooking other foods in other containers, place the solid tray directly underneath the perforated container to catch any drips and therefore avoid any colour transfer.

Duration

The cooking duration depends on the size of the food and how well cooked you want it, just as it does with conventional cooking methods.

Example:

Firm potatoes, cut into quarters:
approx. 12 minutes

Firm potatoes, cut in half:
approx. 17 minutes

Settings

Steam cooking 
Temperature: 100 °C
Duration: see chart

Steam cooking

| Vegetables | 🕒 [min.] |
|--|-------------------------|
| Artichokes | 32–38 |
| Cauliflower, whole | 27–28 |
| Cauliflower, florets | 8 |
| Beans, green | 6–8 |
| Broccoli, florets | 2–4 |
| Chantenay carrots, whole | 7–8 |
| Chantenay carrots, halved | 5–6 |
| Chantenay carrots, chopped | 4 |
| Chicory, halved | 4–5 |
| Chinese cabbage, chopped | 3 |
| Peas | 2 |
| Fennel, halved | 10–12 |
| Fennel, sliced | 4–5 |
| Kale, chopped | 23–26 |
| Firm potatoes, peeled whole halved quartered | 20–25 15–20 10–15 |
| Fairly firm potatoes, peeled whole halved quartered | 23–28 18–23 14–18 |
| Soft potatoes, peeled whole halved quartered | 25–30 20–25 15–20 |
| Kohlrabi, cut into batons | 6–7 |
| Pumpkin, diced | 4–8 |
| Corn on the cob | 10–15 |
| Silverbeet, chopped | 2–3 |
| Capsicum, diced or sliced | 2 |

Steam cooking

| Vegetables | 🕒 [min.] |
|---------------------------|-----------------|
| New potatoes, firm | 20–25 |
| Mushrooms | 2 |
| Leeks, sliced | 2–4 |
| Leeks, halved lengthways | 4–6 |
| Romanesco, whole | 22–25 |
| Romanesco, florets | 5–7 |
| Brussels sprouts | 10–12 |
| Beetroot, whole | 50–60 |
| Red cabbage, chopped | 15–20 |
| Black salsify, whole | 9–10 |
| Celeriac, cut into batons | 6–7 |
| Asparagus, green | 2–4 |
| Asparagus, white | 5–10 |
| Carrots, chopped | 6 |
| Spinach | 1–2 |
| Spring cabbage, chopped | 10–11 |
| Celery, chopped | 2–5 |
| Turnips, chopped | 6–7 |
| White cabbage, chopped | 12 |
| Savoy cabbage, chopped | 10–11 |
| Zucchini, sliced | 2–3 |
| Sugar snap peas | 2–3 |

🕒 Duration

Fish

Fresh

Prepare fresh fish in the usual way, i.e. clean, gut and fillet.

Frozen

Fish does not need to be fully defrosted before cooking. Defrost so that the surface is sufficiently thawed to take herbs and seasoning. Depending on the thickness of the fish, 2–5 minutes should be enough.

Preparation

Add some lemon or lime juice to fish before cooking. The citric acid helps the flesh stay firm.

It is not necessary to season fish when cooking with steam as this method retains the minerals which give the fish its unique flavour.

Cooking containers

If using a perforated container, grease it first or line it with baking paper.

Shelf level

When cooking fish in a perforated container at the same time as cooking other types of food in other containers, place the container with the fish directly above the glass or collecting tray (depending on the model) to catch any liquid and so avoid any transfer of flavours to other food.

Temperature

85 °C – 90 °C

For gently cooking delicate types of fish, such as flounder.

100 °C

For cooking firmer types of fish, e.g. salmon.

Also for cooking fish in sauce or stock.

Duration

The cooking duration depends on the thickness and the texture of the fish, and not on the weight. The thicker the fish, the longer the cooking duration. A 3 cm thick piece of fish weighing 500 g will take longer to cook than a 2 cm thick piece of fish weighing 500 g.

The longer fish cooks, the firmer its flesh will become. Use the cooking durations given in the chart. If you find that the fish is not cooked sufficiently, only cook it for a few minutes more.

When cooking fish in sauce or stock, we recommend that you increase the cooking duration quoted by a few minutes.

Steam cooking

Useful tips

- Adding herbs and spices, such as dill, will help bring out the full flavour of the fish.
- Cook large fish in the swimming position. To help maintain the structure of the fish, place a small cup or similar upside down in the cooking container. Arrange the fish bellyside down over the cup.
- You can use any fish scraps, e.g. fish heads, bones, tails etc. to make a **fish stock**. Place the fish scraps together with some mixed vegetables in a solid cooking container and add cold water. Cook at 100 °C for 60 to 90 minutes. The longer the cooking duration, the stronger the stock.
- Preparing fish **au bleu** is a method involving cooking the fish in water with vinegar, at different proportions depending on the recipe. It is important not to damage the skin of the fish. This method is suitable for cooking trout, tench, eel and salmon.

Settings

Steam cooking 
Temperature: see chart
Duration: see chart

Steam cooking

| Fish | 🌡️ [°C] | 🕒 [min.] |
|---------------------------------|---------|----------|
| Eel | 100 | 5–7 |
| Perch fillet | 100 | 3–5 |
| Bream/Snapper fillet | 85 | 3–5 |
| Trout, 250 g | 90 | 8–12 |
| Halibut/Trumpeter fillet | 85 | 4–6 |
| Blue eye trevalla/Ling fillet | 100 | 6 |
| Salmon fillet | 100 | 4–8 |
| Salmon steak | 100 | 8–10 |
| Australian salmon | 90 | 8–10 |
| Basa fillet | 85 | 3 |
| Rosefish fillet | 100 | 6–8 |
| Jackass morwong/Terakihi fillet | 100 | 4–6 |
| Flounder fillet | 85 | 4–5 |
| Stargazer/Monkfish fillet | 85 | 6–8 |
| Sole fillet | 85 | 3 |
| Turbot fillet | 85 | 5–8 |
| Tuna fillet | 85 | 4–8 |

🌡️ Temperature, 🕒 duration

Steam cooking

Meat

Fresh

Prepare the meat in the usual way.

Frozen food

Meat should be thoroughly defrosted before cooking (see “Special applications – Defrost”).

Preparation

Meat which needs to be seared before being cooked, e.g. stewing steak, should be seared in a pan on the cooktop.

Duration

The cooking duration depends on the thickness and the texture of the meat, and not on the weight. The thicker the piece of meat, the longer the cooking duration. A piece of meat weighing 500 g which is 10 cm thick will take longer to cook than a piece of meat weighing 500 g which is 5 cm thick.

Useful tips

- To retain the **flavourings**, use a perforated cooking container. Place an unperforated cooking container underneath in order to collect the concentrate. You can use the concentrate to enhance your sauces or freeze it for later use.
- Boiling chicken, back or top rib and meat bones can be used to make **stock**. Place the meat together with the bones and some mixed vegetables in a cooking container and add cold water. The longer the cooking duration, the stronger the stock.

Settings

Steam cooking SSS
Temperature: 100 °C
Duration: see chart

Steam cooking

| Meat | 🕒 [min.] |
|-------------------------------------|-----------------|
| Beef shin, covered with water | 110–120 |
| Pork knuckle | 135–140 |
| Chicken breast fillet | 8–10 |
| Knuckle | 105–115 |
| Beef soup bones | 110–120 |
| Veal for stewing | 3–4 |
| Gammon steaks | 6–8 |
| Lamb stew | 12–16 |
| Turkey roulade | 12–15 |
| Turkey schnitzel | 4–6 |
| Rib of beef, covered with water | 130–140 |
| Beef stew | 105–115 |
| Boiling chicken, covered with water | 80–90 |
| Silverside | 110–120 |

🕒 Duration

Steam cooking

Rice

Rice swells when cooked and needs to be cooked in liquid. The proportion of rice to liquid will vary depending on the type of rice.

The rice absorbs all the liquid during the cooking process so that none of the nutrients are lost.

Settings

Steam cooking 

Temperature: 100 °C

Duration: see chart

| | Ratio Rice : Liquid |  [min.] |
|----------------|--------------------------------|---|
| Basmati rice | 1 : 1.5 | 15 |
| Parboiled rice | 1 : 1.5 | 23–25 |
| Arborio rice | | |
| Milk rice | 1 : 2.5 | 30 |
| Risotto rice | 1 : 2.5 | 18–19 |
| Brown rice | 1 : 1.5 | 26–29 |
| Wild rice | 1 : 1.5 | 26–29 |

 Duration

Grains

Grains swell when cooked and need to be cooked in liquid. The proportion of grains to liquid depends on the type of grain.

Grains can be cooked whole or cracked.

Settings

Steam cooking 

Temperature: 100 °C

Duration: see chart

| | Ratio Grain : Liquid |  [min.] |
|----------------------|-------------------------|--|
| Amaranth | 1 : 1.5 | 15–17 |
| Bulgur | 1 : 1.5 | 9 |
| Green spelt, whole | 1 : 1 | 18–20 |
| Green spelt, cracked | 1 : 1 | 7 |
| Oats, whole | 1 : 1 | 18 |
| Oats, cracked | 1 : 1 | 7 |
| Millet | 1 : 1.5 | 10 |
| Polenta | 1 : 3 | 10 |
| Quinoa | 1 : 1.5 | 15 |
| Rye, whole | 1 : 1 | 35 |
| Rye, cracked | 1 : 1 | 10 |
| Wheat, whole | 1 : 1 | 30 |
| Wheat, cracked | 1 : 1 | 8 |

 Duration

Steam cooking

Pasta/Noodles

Dry pasta and noodles

Dry pasta and noodles swell when they are cooked and need to be cooked in liquid. The liquid must cover the pasta or noodles. Using hot liquid gives better results. Increase the cooking time stated by the manufacturer by approx. 1/3.

Fresh food

Fresh pasta and noodles, such as those you can buy from the supermarket chilled counter, do not need to absorb water. Cook in a greased, perforated container. Separate any pieces of pasta or noodles which have stuck together and spread them out in the cooking container.

Settings

Steam cooking 
Temperature: 100 °C
Duration: see chart

| Fresh pasta / noodles |  [min.] |
|--|--|
| Gnocchi | 2 |
| Knöpfli | 1 |
| Ravioli | 2 |
| Spätzle | 1 |
| Tortellini | 2 |
| Dry pasta / noodles, covered with water | |
| Flat noodles / Fettuccine | 14 |
| Vermicelli | 8 |

 Duration

European dumplings

Ready-made dumplings in wrappers need to be covered completely with water. Otherwise they will not absorb enough water and will fall apart, even if steeped in water prior to cooking.

Cook fresh dumplings in a greased, perforated container.

Settings

Steam cooking 

Temperature: 100 °C

Duration: see chart

| |  [min.] |
|----------------------------------|--|
| Steamed dumplings | 30 |
| Yeast dumplings | 20 |
| Boil-in-the-bag potato dumplings | 20 |
| Boil-in-the-bag bread dumplings | 18–20 |

 Duration

Steam cooking

Dried pulses

Soak pulses for at least 10 hours in cold water before cooking. Soaking makes the pulses more digestible and shortens the cooking duration required. Soaked pulses must be covered with liquid during cooking.

Lentils do not need to be soaked before cooking.

With unsoaked pulses a certain ratio of pulses to liquid is required.

Settings

Steam cooking 

Temperature: 100 °C

Duration: see chart

| Soaked | |
|---------------------|--|
| |  [min.] |
| Beans | |
| Kidney beans | 55–65 |
| Adzuki beans | 20–25 |
| Black beans | 55–60 |
| Borlotti beans | 55–65 |
| Haricot beans | 34–36 |
| Peas | |
| Yellow split peas | 40–50 |
| Green peas, shelled | 27 |

 Duration

Steam cooking

| Unsoaked | | |
|---------------------|--------------------------|----------|
| | Ratio Pulses : Liquid | 🕒 [min.] |
| Beans | | |
| Kidney beans | 1 : 3 | 130–140 |
| Adzuki beans | 1 : 3 | 95–105 |
| Black beans | 1 : 3 | 100–120 |
| Borlotti beans | 1 : 3 | 115–135 |
| Haricot beans | 1 : 3 | 80–90 |
| Lentils | | |
| Brown lentils | 1 : 2 | 13–14 |
| Red lentils | 1 : 2 | 7 |
| Peas | | |
| Yellow split peas | 1 : 3 | 110–130 |
| Green peas, shelled | 1 : 3 | 60–70 |

🕒 Duration

Steam cooking

Hen's eggs

Use a perforated container to prepare boiled eggs.

The eggs do not need to be pierced before cooking as they are gradually warmed during the heating-up phase and so do not burst when they are cooked with steam.

When using a solid container for preparing egg dishes, remember to grease it first.

Settings

Steam cooking 

Temperature: 100 °C

Duration: see chart

| |  [min.] |
|---|--|
| Small (S) soft medium hard | 3 5 9 |
| Medium (M) soft medium hard | 4 6 10 |
| Large (L) soft medium hard | 5 6–7 12 |
| Extra large (XL) soft medium hard | 6 8 13 |

 Duration

Fruit

Cook fruit in a solid container so that none of the juice is lost. If you wish to cook fruit in a perforated container, place a solid container directly underneath it to collect the juice.

Useful tip: You can use the collected juice to prepare a glaze for a fruit flan.

Settings

Steam cooking 
 Temperature: 100 °C
 Duration: see chart

| |  [min.] |
|------------------------|--|
| Apple chunks | 1–3 |
| Pear chunks | 1–3 |
| Cherries | 2–4 |
| Mirabelle plums | 1–2 |
| Nectarine/Peach chunks | 1–2 |
| Plums | 1–3 |
| Quinces, diced | 6–8 |
| Rhubarb chunks | 1–2 |
| Gooseberries | 2–3 |

 Duration

Sausages

Settings

Steam cooking 
 Temperature: 90 °C
 Duration: see chart

| Sausages |  [min.] |
|----------------|--|
| Frankfurters | 6–8 |
| Sausages | 6–8 |
| White sausages | 6–8 |

 Duration

Steam cooking

Shellfish

Preparation

Defrost frozen shellfish before cooking with steam.

Peel, remove and discard the intestines, and then wash the shellfish.

Cooking containers

If using a perforated container, grease it first or line it with baking paper.

Duration

The longer shellfish are cooked, the tougher they become. Use the cooking durations given in the chart.



When cooking shellfish in sauce or stock, we recommend that you increase the cooking duration quoted by a few minutes.

Settings

Steam cooking 

Temperature: see chart

Duration: see chart

| |  [°C] |  [min.] |
|---------------|--|--|
| Crevettes | 90 | 3 |
| Prawns | 90 | 3 |
| King prawns | 90 | 4 |
| Small shrimps | 90 | 3 |
| Crayfish | 95 | 10–15 |
| Large shrimps | 90 | 3 |

 Temperature,  duration

Mussels

Fresh food

 Danger of food poisoning from spoiled mussels.
Spoiled mussels can cause food poisoning.
Only cook mussels which are closed.
Do not eat mussels which have not opened after being cooked.

Steep fresh mussels in water for a few hours before cooking to rinse out any sand. Then scrub the mussels thoroughly to clean them.

Frozen

Defrost frozen mussels before cooking.

Duration



The longer mussels are cooked, the harder they become. Use the cooking durations given in the chart.

Settings

Steam cooking 

Temperature: see chart

Duration: see chart

| |  [°C] |  [min.] |
|-----------------|--|--|
| Goose barnacles | 100 | 2 |
| Cockles | 100 | 2 |
| Blue mussels | 90 | 12 |
| Scallops | 90 | 3 |
| Razor clams | 100 | 2–4 |
| Vongole | 90 | 2–4 |

 Temperature,  duration

Steam cooking

Menu cooking

Before cooking meals with the manual Menu cooking function, switch off steam reduction (see “Settings – Steam reduction”).

Menu cooking involves cooking various foods with different cooking times in order to serve them all together in one meal, e.g. rosefish fillet with rice and broccoli. Foods are placed in the oven compartment at different times so that they are all ready at the same time.

Shelf level

Place foods that produce a lot of liquids (e.g. fish) or have a distinctive colour (e.g. beetroot) directly above the glass tray or condensate tray (depending on the model). This avoids any transfer of flavour or colour to other food by preventing liquid dripping onto food below it.

Temperature

Whole meals should be cooked at a temperature of 100 °C as this is the temperature required to cook the majority of foods. Do not cook a whole meal at the lowest temperature when different temperatures are required for different types of food, e.g. 85 °C for seabream and 100 °C for potatoes.

If the recommended cooking temperature for the food is 85 °C for example, try cooking it at 100 °C and testing the result. Some delicate types of fish with a soft structure, e.g. flounder will become very firm when cooked at 100 °C.

Duration

If you increase the recommended temperature, shorten the cooking duration by approx. $\frac{1}{3}$.

Example:

Food cooking durations

(see cooking charts in “Steam cooking”)

| | |
|-----------------|------------|
| Parboiled rice | 24 minutes |
| Rosefish fillet | 6 minutes |
| Broccoli | 4 minutes |

Calculation of set cooking durations:

24 minutes minus

6 minutes = 18 minutes (1st cooking duration: rice)

6 minutes minus 4 minutes = 2 minutes (2nd cooking duration: rosefish fillet)

Remaining time = 4 minutes

(3rd cooking duration: broccoli)

| | | | |
|----------|--------------------------|--------|-------------------|
| Duration | 24 min. – rice | | |
| | 6 min. - rosefish fillet | | 4 min. - broccoli |
| | 18 min. | | |
| Setting | 18 min. | 2 min. | 4 min. |

Cooking a whole menu

- Place the rice in the oven first.
- Set the first cooking duration: 18 minutes.
- After the 18 minutes, place the fish in the oven.
- Set the second cooking duration: 2 minutes.
- After the 2 minutes, place the broccoli in the oven.
- Set the third cooking duration: 4 minutes.

Reheat

The steam oven is very effective at reheating food gently, without drying it out or cooking it further. The food reheats evenly and does not need to be stirred during the reheating process.

You can reheat individual dishes or plated meals which have been prepared previously (e.g. meat, vegetables and potatoes).

Crockery

Small amounts can be reheated on a plate. Larger amounts should be reheated in a steam oven container.

Duration

The number of plates or containers has no bearing on the time.

The times listed in the table relate to an average portion per plate. Increase the duration for larger quantities.

Useful tips

- Do not reheat large items, such as a joint of roast meat, whole. Divide it into portions and reheat these as plated meals.
- Compact items, such as stuffed capsicum, roulades or dumplings, should be cut in half.
- Reheat sauces separately. Exceptions are dishes such as goulash, which is cooked in sauce.
- Cover food when reheating it. This will avoid steam condensing on the crockery.
- Please note that breaded items, such as schnitzel, will not retain their crispness when they are reheated.

Heating food

- Cover the food being warmed up with a plate or foil that is resistant to temperatures up to 100 °C and to steam.
- Place the food on the rack or in a cooking container.

Settings

Steam cooking SSS

Temperature: 100 °C

Duration: see chart

Other applications

The durations specified in the chart are guidelines only. We recommend selecting the shorter duration initially. You can make the duration longer if necessary.

| Food | ⌚* [min.] |
|---|-----------|
| Vegetables | |
| Carrots Cauliflower Kohlrabi Beans | 6–7 |
| Side dishes | |
| Pasta Rice | 3–4 |
| Potatoes, halved lengthways | 12–14 |
| European dumplings | 15–17 |
| Meat and poultry | |
| Sliced meat, 1.5 cm thick Roulades, sliced Goulash Lamb stew | 5–6 |
| Meatballs | 13–15 |
| Chicken schnitzel Turkey schnitzel | 7–8 |
| Fish | |
| Fish fillets, 2 cm thick | 6–7 |
| Fish fillets, 3 cm thick | 7–8 |
| Plated meals | |
| Spaghetti with tomato sauce | 13–15 |
| Roast pork, potatoes, vegetables | 12–14 |
| Stuffed capsicum (halved), rice | 13–15 |
| Chicken fricassee, rice | 7–8 |
| Vegetable soup | 2–3 |
| Creamy soup | 3–4 |
| Consommé | 2–3 |
| Casserole | 4–5 |

⌚ Duration

* These times apply to food heated on a plate and covered with a plate.

Defrost

It is much quicker to defrost items in the steam oven than at room temperature.

 Risk of infection from bacteria.

Bacteria such as salmonella can cause life-threatening food poisoning. It is particularly important to observe food hygiene rules when defrosting fish and meat, and in particular when defrosting poultry.

Do not use the liquid produced during defrosting.

Process the food as required as soon as it has been defrosted.

Temperature

60 °C is the best temperature for defrosting.

Exceptions: 50 °C for minced meat and game.

Before and after defrosting

Remove any packaging before defrosting.

Exceptions: Leave bread, biscuits and cakes in their packaging as otherwise they will absorb moisture and become soft.

Allow food to stand at room temperature for a few minutes after defrosting. The standing time is necessary to allow the even distribution of heat from the outside to the inside.

Cooking containers

Use a perforated container with a glass tray or condensate tray (depending on model) underneath it when defrosting food which will drip, such as poultry. This way food will not be lying in defrosted liquid.

Foods which do not drip can be defrosted in a solid cooking container.

Useful tips

- Fish does not need to be fully defrosted before cooking. Defrost so that the surface is sufficiently thawed to take herbs and seasoning. Depending on the thickness of the fish, 2–5 minutes is generally enough.
- When defrosting food which has frozen together, e.g. berries and meat portions, separate them half-way through the defrosting time.
- Do not refreeze food once it has thawed.
- Defrost frozen ready meals according to the instructions on the packaging.

Settings

Steam cooking 

Temperature: see chart

Defrosting duration: see chart

Standing time: see chart

Other applications

The durations specified in the chart are guidelines only. We recommend selecting the shorter defrosting duration initially. You can make the defrosting duration longer if necessary.

| Frozen food | Quantity | 🌡️ [°C] | 🕒 [min.] | 🕒 [min.] |
|--|----------------|---------|----------|----------|
| Dairy products | | | | |
| Sliced cheese | 125 g | 60 | 15 | 10 |
| Quark | 250 g | 60 | 20–25 | 10–15 |
| Cream | 250 g | 60 | 20–25 | 10–15 |
| Soft cheese | 100 g | 60 | 15 | 10–15 |
| Fruit | | | | |
| Apple sauce | 250 g | 60 | 20–25 | 10–15 |
| Apple pieces | 250 g | 60 | 20–25 | 10–15 |
| Apricots | 500 g | 60 | 25–28 | 15–20 |
| Strawberries | 300 g | 60 | 8–10 | 10–12 |
| Raspberries/Red/Blackcurrants | 300 g | 60 | 8 | 10–12 |
| Cherries | 150 g | 60 | 15 | 10–15 |
| Peaches | 500 g | 60 | 25–28 | 15–20 |
| Plums | 250 g | 60 | 20–25 | 10–15 |
| Gooseberries | 250 g | 60 | 20–22 | 10–15 |
| Vegetables | | | | |
| Frozen in a block | 300 g | 60 | 20–25 | 10–15 |
| Fish | | | | |
| Fish fillets | 400 g | 60 | 15 | 10–15 |
| Trout | 500 g | 60 | 15–18 | 10–15 |
| Lobster | 300 g | 60 | 25–30 | 10–15 |
| Small shrimps | 300 g | 60 | 4–6 | 5 |
| Ready meals | | | | |
| Meat, vegetables, sides / Casserole / Soup | 480 g | 60 | 20–25 | 10–15 |
| Meat | | | | |
| Roast meat slices | 125–150 g each | 60 | 8–10 | 15–20 |
| Minced meat | 250 g | 50 | 15–20 | 10–15 |
| | 500 g | 50 | 20–30 | 10–15 |

Other applications

| Frozen food | Quantity | 🌡️ [°C] | 🕒 [min.] | ⌚ [min.] |
|--------------------------------|----------|---------|----------|----------|
| Stew | 500 g | 60 | 30–40 | 10–15 |
| | 1000 g | 60 | 50–60 | 10–15 |
| Liver | 250 g | 60 | 20–25 | 10–15 |
| Saddle of hare | 500 g | 50 | 30–40 | 10–15 |
| Roebuck saddle | 1000 g | 50 | 40–50 | 10–15 |
| Schnitzel/Chops/Sausages | 800 g | 60 | 25–35 | 15–20 |
| Poultry | | | | |
| Chicken | 1000 g | 60 | 40 | 15–20 |
| Chicken thighs | 150 g | 60 | 20–25 | 10–15 |
| Chicken fillet | 500 g | 60 | 25–30 | 10–15 |
| Turkey drumsticks | 500 g | 60 | 40–45 | 10–15 |
| Baked goods | | | | |
| Puff pastries/Yeast buns | – | 60 | 10–12 | 10–15 |
| Creamed mixture cakes/biscuits | 400 g | 60 | 15 | 10–15 |
| Bread/Rolls | | | | |
| Bread rolls | – | 60 | 30 | 2 |
| Rye bread, sliced | 250 g | 60 | 40 | 15 |
| Whole grain bread, sliced | 250 g | 60 | 65 | 15 |
| White bread, sliced | 150 g | 60 | 30 | 20 |

🌡️ Temperature 🕒 Defrosting duration ⌚ Standing time

Other applications

Blanch

Blanch fruit and vegetables before freezing them. Blanching helps maintain the quality of the produce when it is frozen.

Blanching vegetables also helps them retain their original colour.

- Put the prepared vegetables (cleaned, washed, chopped etc.) into a perforated cooking container and place in the oven compartment.
- Once blanched, plunge the vegetables into ice cold water to cool them down quickly. Drain them well.

Settings

Steam cooking 
Temperature: 100 °C
Duration: 1 minute

Bottling

Only use unblemished, fresh produce which is in good condition.

Glass jars

Use clean glass jars and accessories and check them for any defects. Glass jars with twist off lids or glass lids with a rubber seal are suitable.

Make sure that all the glass jars are the same size so that bottling is carried out evenly.

After you have filled the jars with the bottled produce, clean the glass rims with a clean cloth and hot water and then seal the jars.

Fruit

Sort fruit carefully, rinse it briefly but thoroughly and allow it to drain. Take great care when cleaning soft fruit as it is very delicate and squashes easily.

Remove any peel, stalks, cores or stones. Cut up large fruit. For example, cut apples into slices.

If you are bottling fruit with stones (e.g. plums, apricots) without removing the stones, pierce the fruit several times with a fork or wooden skewer as otherwise it will burst.

Vegetables

Rinse, clean and cut up vegetables.

Vegetables should be blanched before bottling to help them retain their colour (see “Other applications – Blanch”).

Fill volume

Fill the glass jars with produce up to no more than 3 cm below the rim. Do not pack it down as this will damage the cell walls of the produce. Tap the jar gently onto a cloth to help distribute the contents evenly. Fill the jars with liquid. The produce must be completely covered.

Use a sugar solution for fruit and a salt or vinegar solution for vegetables.

Meat and sausages

Briefly fry or cook the meat before bottling. Use the juices with some added water, or the broth in which the meat was cooked, as the liquid content of the jars. Make sure there is no grease on the rim of the jars.

When bottling sausages, only fill the jars to halfway as the meat will rise during the bottling process.

Useful tips

- Make use of residual heat by leaving the jars in the oven for 30 minutes after it has switched off.
- Then cover the jars with a cloth and allow to cool for approx. 24 hours.

Bottling food

- Place the rack on shelf level 1.
- Place the closed jars on the rack. The jars must not touch each other.

Settings

Steam cooking 

Temperature: see chart

Bottling duration: see chart

Other applications

| Food | 🌡️ [°C] | 🕒* [min.] |
|--------------------------|---------|-----------|
| Berries | | |
| Red / Blackcurrants | 80 | 50 |
| Gooseberries | 80 | 55 |
| Cranberries | 80 | 55 |
| Fruit with stones | | |
| Cherries | 85 | 55 |
| Mirabelle plums | 85 | 55 |
| Plums | 85 | 55 |
| Peaches | 85 | 55 |
| Greengage plums | 85 | 55 |
| Fruit with pips | | |
| Apples | 90 | 50 |
| Apple sauce | 90 | 65 |
| Quinces | 90 | 65 |
| Vegetables | | |
| Beans | 100 | 120 |
| Broad beans | 100 | 120 |
| Gherkins | 90 | 55 |
| Beetroot | 100 | 60 |
| Meat | | |
| Pre-cooked | 90 | 90 |
| Roasted | 90 | 90 |

🌡️ Temperature, 🕒 Duration

* Bottling durations apply to 1.0 l jars. If using 0.5 l jars, reduce the duration by 15 minutes. If using 0.25 l jars, reduce the duration by 20 minutes.

Disinfect items

The steam oven will disinfect baby bottles and other containers so that at the end of the programme they are as germ free as they would have been if boiled. Check beforehand that all parts, teats etc. are declared by the manufacturer to be heat resistant to 100 °C and also that they can withstand hot steam.

Dismantle, clean and thoroughly rinse baby bottles. Reassemble the bottles only after they have completely dried. This prevents recontamination.

- Place the individual items on the rack or in a perforated container (on their sides or with the opening facing downwards) ensuring that they do not touch one another. This will allow hot steam to reach them from all sides.

Settings

Steam cooking SSS
Temperature: 100 °C
Duration: 15 minutes

Prove yeast dough

- Prepare the dough according to the recipe.
- Place the dough in a bowl on the rack.

Settings

Steam cooking SSS
Temperature: 40 °C
Duration: as per recipe instructions

Heat damp towels

- Moisten towels and then roll them up.
- Place them beside one another in a perforated cooking container.

Settings

Steam cooking SSS
Temperature: 70 °C
Duration: 2 minutes

Dissolve gelatine

- Soften **gelatine leaves** by leaving them in a bowl of cold water for 5 minutes. The gelatine leaves have to be fully covered with water. Remove the gelatine leaves from the bowl and squeeze them out. Empty the bowl. Place the squeezed gelatine leaves back in the bowl.
- **Gelatine powder:** Place the gelatine powder in a bowl and add water according to the instructions on the packaging.
- Cover the bowl and place on the rack.

Settings

Steam cooking SSS
Temperature: 90 °C
Duration: 1 minute

Other applications

Decrystallise honey

- Loosen the lid and place the jar of honey in a perforated cooking container.
- Stir the honey once during the process.

When liquefying (decrystallising) honey at a temperature of 60 °C, the main focus is on obtaining a spreadable food product again.

Settings

Steam cooking SSS

Temperature: 60 °C

Duration: 90 minutes (irrespective of the size of jar or the amount of honey in the jar)

Melt chocolate

You can use the steam oven for melting any type of chocolate.

When using a cake glaze, place it in a perforated cooking container, leaving it in its packaging.

- Break the chocolate into small pieces.
- Place large quantities in a solid container and small quantities in a cup or a bowl.
- Cover the container or the dish with a lid or with foil that is resistant to temperatures up to 100 °C and to hot steam.
- Stir large quantities once during cooking.

Settings

Steam cooking SSS

Temperature: 65 °C

Duration: 20 minutes

Make yoghurt

To prepare yoghurt, you will need milk and live culture or yoghurt starter powder, e.g. from a health food store.

Use natural yogurt with live culture and without additives. Do not use heat-treated yogurt.

The yoghurt must be fresh (short storage time).

You can use either unchilled long-life milk or fresh milk.

Long-life milk can be used as it is – no further preparation is required. Fresh milk must first be heated to 90 °C (do not boil it) and then cooled down to 35 °C. Fresh milk will give a better set than long-life milk.

The yoghurt and milk should have the same percentage fat.

Do not move or shake the jars while the yoghurt is fermenting.

Immediately after preparation, leave the yoghurt to cool in the fridge.

The firmness, fat content and cultures used in the yoghurt starter all affect the consistency of homemade yoghurt. Not all yoghurts are equally suitable as yoghurt starters.

Useful tip: If you are using yoghurt starter powder, you can prepare the yoghurt from a mixture of milk and cream. For that, mix $\frac{3}{4}$ litre milk with $\frac{1}{4}$ litre cream.

- Mix 100 g yoghurt with 1 litre of milk or make up the mixture with yoghurt enzyme, following the instructions on the packaging.
- Pour the mixture into glass jars and seal the jars.
- Place the sealed jars in a perforated cooking container or on the rack. The jars must not touch each other.
- Straight after the cooking duration has finished, place the jars in the refrigerator. Take care not to shake the jars unnecessarily.

Settings

Steam cooking 

Temperature: 40 °C

Duration: 5:00 hours

Possible causes for poor results

Yoghurt is not set:

Incorrect storage of the yoghurt starter, too much time out of the refrigerator, packaging was damaged, milk was insufficiently heated.

Liquid has not been removed:

Jars were moved, the yoghurt cooled down too slowly.

Yoghurt is grainy:

The milk was heated too high, it was not free of imperfections, the milk and yoghurt starter were not stirred evenly.

Other applications

Render fat

The bacon will not become brown.

- Place the bacon (diced or rashers) in a solid cooking container.
- Cover the container with foil that is temperature-resistant up to 100 °C and resistant to steam.

Settings

Steam cooking SSS
Temperature: 100 °C
Duration: 4 minutes

Sweat onions

Sweating means cooking the onions in their own juices, with the addition of a little fat if necessary.

- Cut the onions up into small pieces and place them in a solid cooking container with a little butter.
- Cover the container with foil that is temperature-resistant up to 100 °C and resistant to steam.

Settings

Steam cooking SSS
Temperature: 100 °C
Duration: 4 minutes

Extracting juice

This appliance is ideal for extracting juice from soft, firm and hard fruit.

It is best to use overripe fruit, as the riper the fruit, the greater the quantity of juice produced. Very ripe fruit will also produce a more intense flavour.

Preparation

Sort and rinse the fruit, and cut out any blemishes.

Remove the stalks from grapes and morello cherries as these are bitter. Berries do not need to have their stalks removed.

Dice larger fruit such as apples into approximately 2 cm cubes. The harder the fruit, the smaller the pieces should be.

Useful tips

- Try experimenting with mild and tart flavours. For example, mix apples with elderberries.
- Adding sugar will increase the quantity of juice produced and improve the flavour. Sprinkle the fruit with sugar and leave to absorb for a few hours before juicing. For 1 kg of sweet fruit add 50–100 g of sugar, and for 1 kg of tart fruit add 100–150 g of sugar.
- If you wish to bottle the juice rather than consume it straight away, pour it whilst hot into hot, sterilised bottles up to the rim, and then seal immediately with sterilised rubber tops.

Extracting juice from fruit

- Put the prepared fruit (cleaned, washed, chopped etc.) into a perforated cooking container.
- Place a solid container or a glass tray or condensate tray (depending on the model) underneath to catch the juice.

Settings

Steam cooking SSS
Temperature: 100 °C
Duration: 40–70 minutes

Skinning fruit and vegetables

- Cut a cross in the top of tomatoes, nectarines etc. This will allow the skin to be removed more easily.
- Place the fruit/vegetables in a perforated cooking container.
- To blanch almonds, it is important to plunge them into cold water as soon as they are taken out of the oven as otherwise the skin cannot be removed.

Settings

Steam cooking 
Temperature: 100 °C
Duration: see chart

| Produce |  [min.] |
|------------|--|
| Apricots | 1 |
| Almonds | 1 |
| Nectarines | 1 |
| Capsicum | 4 |
| Peaches | 1 |
| Tomatoes | 1 |

 Duration

Preserving apples

You can treat homegrown apples to increase the length of time for which you can store them. Once treated, the apples will keep for 5 to 6 months when stored in a dry, cool and well-ventilated place. This method is only suitable for apples and not for other types of fruit.

Settings

Steam cooking 
Temperature: 50 °C
Duration: 5 minutes

Preparing custard royale

- Stir 6 eggs into 375 ml milk (do not beat into a foam).
- Season the egg/milk mixture and pour into a solid cooking container greased with butter.

Settings

Steam cooking 
Temperature: 100 °C
Duration: 4 minutes



Automatic programmes



Your steam oven is equipped with over 20 Automatic programmes for cooking vegetables. The temperature and cooking duration are preset, so you only have to prepare the vegetables as required (see the “Programme overview” chart).







The oven interior needs to be at room temperature before starting an Automatic programme.

For hints and tips on cooking vegetables using steam, see “Steam cooking – Vegetables”.

Using Automatic programmes

- Put the prepared vegetables into a perforated cooking container.
- Place the condensate tray on shelf level 1.
Place the perforated container on any shelf level.
- Fill the water container with fresh tap water and push it into the appliance.
- Switch the steam oven on.
- Touch the  /  sensor.
EEO appears in the display.

You can switch to the Automatic programmes by touching the  or  sensor.

- Set the programme you want with the  or  sensor, e.g. A15.
- Confirm with *OK*.
- Set the degree of cooking you want with the  or  sensor:
 - al dente 
 - Medium 
 - Soft 
- Confirm with *OK*.

Programme overview

| Programme number | Vegetables | |
|------------------|-----------------------|---------------------|
| A1 | Cauliflower | Florets, medium |
| A2 | Beans (green, yellow) | Whole |
| A3 | Broccoli | Florets, medium |
| A4 | Chinese cabbage | Chopped |
| A5 | Peas | — |
| A6 | 2 fennel bulbs | Cut into strips |
| A7 | Kohlrabi | Batons |
| A8 | Pumpkin | Diced |
| A9 | Corn | Cobs |
| A10 | Carrots | Diced/Batons/Sliced |
| A11 | Capsicum | Cut into strips |
| A12 | New potatoes | Firm, medium |
| A13 | Leeks | Sliced into rings |
| A14 | Romanesco | Florets, medium |
| A15 | Brussels sprouts | — |
| A16 | Boiled potatoes | Firm, quartered |
| A17 | Green asparagus | Medium |
| A18 | White asparagus | Medium |
| A19 | Spinach | — |
| A20 | Sugar snap peas | — |

Cleaning and care

Notes on cleaning and care



Risk of injury caused by hot surfaces.

The steam oven gets hot during operation. You could burn yourself on the oven compartment, shelf runners or accessories.

Allow the oven compartment, shelf runners and accessories to cool before cleaning.



Risk of injury due to electric shock.

The steam from a steam cleaning appliance could reach electrical components and cause a short circuit.

Never use a steam cleaner for cleaning the oven.

All surfaces could be discoloured or damaged if unsuitable cleaning agents are used.

All surfaces of this appliance are susceptible to scratching. Scratches on glass surfaces could cause a breakage in certain circumstances.

Only use cleaning agents designed for domestic use.

Remove all cleaning agent residues immediately.

Do not use cleaning agents or washing-up liquids containing aliphatic hydrocarbons as these could cause the seals to swell.

If soiling is left on for any length of time, it may become impossible to remove.

Surfaces may suffer discolouration or damage.

Remove any soiling immediately.

- The appliance and accessories should be cleaned and dried thoroughly after each use.
- Leave the appliance door open until the oven interior is completely dry.

Useful tip: If the steam oven is not going to be used for a longer period of time, it should be thoroughly cleaned and dried beforehand to prevent the build-up of odours and so on. Leave the door open afterwards.

Unsuitable cleaning agents

To avoid damaging the surfaces of your appliance, do not use:

- cleaning agents containing soda, alkalines, ammonia, acids or chlorides
- cleaning agents containing descaling agents
- abrasive cleaning agents, e.g. powder cleaners and cream cleaners
- solvent-based cleaning agents
- stainless steel cleaning agents
- dishwasher cleaners
- glass cleaning agents
- cleaning agents for ceramic cooktops
- hard, abrasive brushes or sponges, e.g. pot scourers, brushes or sponges which have been previously used with abrasive cleaning agents
- dirt eraser sponges
- sharp metal scrapers
- steel wool or metal scourers

- stainless steel spiral pads
- spot cleaning with mechanical cleaning agents
- oven cleaners and sprays

Cleaning the front

- Clean the appliance front with a clean, soft sponge and a solution of warm water and washing-up liquid.
- After cleaning, wipe the surfaces dry using a soft cloth.

Useful tip: A clean, damp microfibre cloth without cleaning agent can also be used.

Cleaning the oven compartment

The oven compartment, the door seal, the inside of the door and the drip channel should be cleaned and dried after each use.

- Remove:
 - condensate using a sponge or absorbent cloth,
 - light, greasy soiling with a sponge and a solution of washing-up liquid and hot water.
- After cleaning, wipe the surface with clean water to remove any cleaning agent residues.
- Then wipe the surfaces dry using a cloth.

After prolonged use, the **floor heater** can become discoloured by drops of liquid, but this does not impair the function.

The **door seal** is designed to last the lifetime of the appliance. Should it for any reason need replacing, please contact Miele (see the end of these operating instructions).

Cleaning the Automatic door opener

Ensure that the door opener does not become soiled with food residues.

- Wipe away soiling **immediately** with a clean sponge and a solution of washing-up liquid and hot water.
- After cleaning, wipe the surface with clean water to remove any cleaning agent residues.

Cleaning the water container

- Remove the water container after each use.
- Remove the spill guard.
- Empty the water container.
- Rinse the water container by hand and then dry it to prevent limescale.
- Refit the spill guard on the water container. Make sure the spill guard engages correctly.

Cleaning accessories

All accessories are dishwasher-safe.

Cleaning the condensate tray, rack and cooking containers

- Wash and dry the condensate tray, rack and cooking containers after each use.
- Any bluish discolouration on the cooking containers can be removed with vinegar. Rinse afterwards with clean water.

Cleaning and care

Cleaning the shelf runners

The shelf runners are suitable for cleaning in a dishwasher.

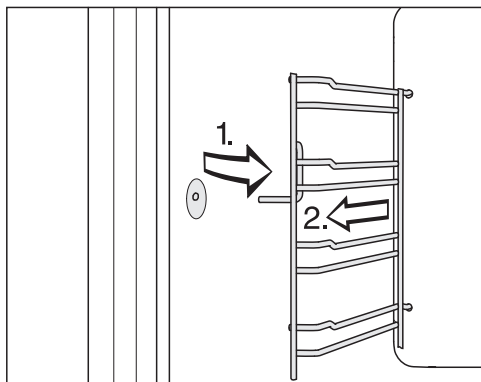

- Pull the shelf runners out of the holder (1.) at the front of the oven and then pull them out of the oven (2.).
- The shelf runners can be washed in the dishwasher or by hand with a solution of warm water and a little washing-up liquid applied with a clean sponge or cloth.

Refit in the reverse order.

- Refit the shelf runners carefully.

If the shelf runners are not correctly inserted, there is no anti-tip protection.

Descaling the steam oven

We recommend using Miele descaling tablets (see “Optional accessories”) to descale the appliance. These have been specially developed for use with Miele appliances to optimise the descaling process. Other descaling agents, which contain other acids besides citric acid and/or other undesirable substances, such as chlorides, could cause damage to the product. Moreover, the descaling result required could not be guaranteed if the descaling solution was not of the appropriate concentration.

Do not spill descaling agent onto metal surfaces. This can cause marks to appear.

However, should any descaling agent get onto these surfaces, wipe it away immediately.



The steam oven has to be descaled after a certain number of operating hours. When it needs descaling, the  symbol and a number will appear when the steam oven is switched on. The number indicates the number of times that the steam oven can be used before it has to be descaled:





The steam oven will lock after the last remaining cooking process.

We recommend that you descale the appliance before it locks out.

During the descaling process, the water container must be rinsed out and refilled with fresh water.

- Touch the On/Off  sensor until the  symbol and, for a few seconds, a surrounding bar appear in the display.

The descaling process is being prepared. As soon as preparation is complete, the  symbol flashes and the descaling time appears.

- Fill the water container with lukewarm fresh tap water up to the level marker  and drop 2 Miele descaling tablets in it.
- Wait until the descaling tablets have dissolved.
- Push the water container into the appliance.
- Confirm with *OK*.

The descaling process will now begin.

Do not switch the steam oven off during the descaling process, otherwise the whole process will have to be started from the beginning again.

During the descaling process, the water container must be rinsed out and refilled **twice** with fresh water. At this point, a buzzer will sound and the  symbol will appear.

- Remove the water container and remove the spill guard.
- Empty the water container and rinse it thoroughly.
- Fill the water container up to the level marker  and push it into the appliance.
- Confirm with *OK*.

The  symbol will go out. Descaling will continue.

After you have rinsed the water container a second time and filled it with fresh tap water, a buzzer will sound a few minutes later. The descaling process is complete.

Finishing the descaling process

- Switch the steam oven off.
- Remove the water container and remove the spill guard.
- Empty and dry the water container.
- Let the oven compartment cool down.
- Then dry the oven compartment.
- Leave the appliance door open until the oven interior is completely dry.



Problem solving guide

Many malfunctions and faults can be easily remedied. You can save time and money in many cases, as you do not need to contact Customer Service.

More information to help you remedy faults yourself can be found at www.miele.com.au/support/customer-assistance or www.miele.co.nz/support/customer-assistance.



Messages in the display

| Problem | Possible cause and remedy |
|---|---|
| DES_ appears briefly in the display after switching on. The oven compartment does not heat up. | Demo mode has been activated. The steam oven can be operated, however the heating elements will not work. ■ Switch off Demo mode (see “Settings”). |
| The  symbol appears in the display and an audible tone may sound. | The water container has not been pushed into the appliance properly. ■ Remove the water container and push it back in so that it connects. |
| | There is not enough water in the water container. The water level must be between the two markings. ■ Fill the water container. |
| The  symbol and a number between 1 and 10 appear. | The appliance needs to be descaled. ■ Descal the steam oven (see “Cleaning and care – Descaling the steam oven”). |
| The display shows a message not listed in this table. | There is an electronic unit fault. ■ Disconnect the power supply to the steam oven for approx. 1 minute. ■ If the problem persists after power is restored, please contact Miele. |

Unexpected behaviour

| Problem | Possible cause and remedy |
|---|--|
| The oven compartment does not heat up. | The oven compartment has been warmed up by a warming drawer in operation underneath it. <ul style="list-style-type: none"> ■ Open the door and let the oven compartment cool down. |
| After moving house, the appliance no longer switches from the heating-up phase to the cooking phase. | Altitude affects the boiling point of water. If you move house, the appliance will need to be reset for the new altitude if this differs from the old one by more than 300 m. <ul style="list-style-type: none"> ■ To adjust the boiling temperature, you need to descale the steam oven (see “Cleaning and care – Descaling the steam oven”). |
| During operation an unusually large amount of steam escapes or steam escapes from parts of the steam oven where it does not usually. | The door is not properly closed. <ul style="list-style-type: none"> ■ Close the door. |
| | The door seal is not correctly fitted. <ul style="list-style-type: none"> ■ If necessary, press it in all the way round the door to make sure it is fitted evenly. |
| | The door seal is damaged, e.g. cracked. <ul style="list-style-type: none"> ■ Replace the door seal. This can be ordered from Miele (see the end of this booklet for contact details). |

Noises

| Problem | Possible cause and remedy |
|--|---|
| A humming sound can be heard during operation and after switching off the steam oven. | This noise does not indicate incorrect operation or an appliance fault. The noise is made by water being pumped through the system. |
| The fan can still be heard after the appliance has been switched off. | The fan is still running. The appliance is fitted with a fan which removes steam from the oven. The fan will continue to run for a while after the appliance has been switched off. It will switch itself off automatically after a while. |
| A whistling sound is heard when the appliance is switched on again. | When the door is closed, the pressure has to equalise, which can cause a whistling sound. This is not a fault. |

Problem solving guide

General problems or technical faults

| Problem | Possible cause and remedy |
|--|--|
| You cannot switch the appliance on. | The circuit breaker has tripped. ■ Reset the circuit breaker in the mains fuse box (see data plate for minimum fuse rating). |
| | There may be a technical fault. ■ Disconnect the appliance from the mains connection for approximately 1 minute by: – switching off at the wall socket and withdrawing the plug, or – switching off the mains circuit breaker or residual current device. ■ If, after switching the circuit breaker or residual current device back on, the steam oven will still not switch on, contact a qualified electrician or Miele. |

You can find information on how to remedy faults yourself at www.miele.com.au/support/customer-assistance or www.miele.co.nz/support/customer-assistance and about Miele spare parts at www.miele.com.au/service or www.miele.co.nz/service.

Warranty

The manufacturer's warranty for this appliance is 2 years.

For further information, please refer to your warranty booklet.

Contact in case of fault

In the event of any faults which you cannot remedy yourself, please contact Miele.

You can book a Miele customer service call-out online at www.miele.com.au/service or www.miele.co.nz/service.

Contact information for Miele can be found at the end of this booklet.

Please quote the model and serial number of your appliance when contacting Miele. This information can be found on the data plate.

The data plate is located inside the compartment for the water container. The model number and serial number can also be found on the small data plate, which can be seen on the front frame when the door is open.

Installation

Safety instructions for installation

 Risk of damage from incorrect installation.

Incorrect installation can cause damage to the steam oven.

The steam oven must only be installed by a qualified person.

▶ The connection data (frequency and voltage) on the steam oven's data plate must correspond with those of the electricity supply in order to ensure that no damage can occur to the steam oven. Compare this data before connecting the appliance. If in any doubt, consult a qualified electrician.

▶ Multi-socket adapters and extension leads do not guarantee the required safety of the appliance (fire hazard). Do not use them to connect the steam oven to the power supply.

▶ The socket and on-off switch should be easily accessible after the steam oven has been installed.

▶ The steam oven must be positioned so that you can see the contents of a cooking container placed on the top shelf level. Otherwise there is a risk of injuries or spillages of hot food.

Installation dimensions

All dimensions are given in mm.

Installation in a tall unit

The furniture housing unit must not have a back panel fitted behind the building-in niche.

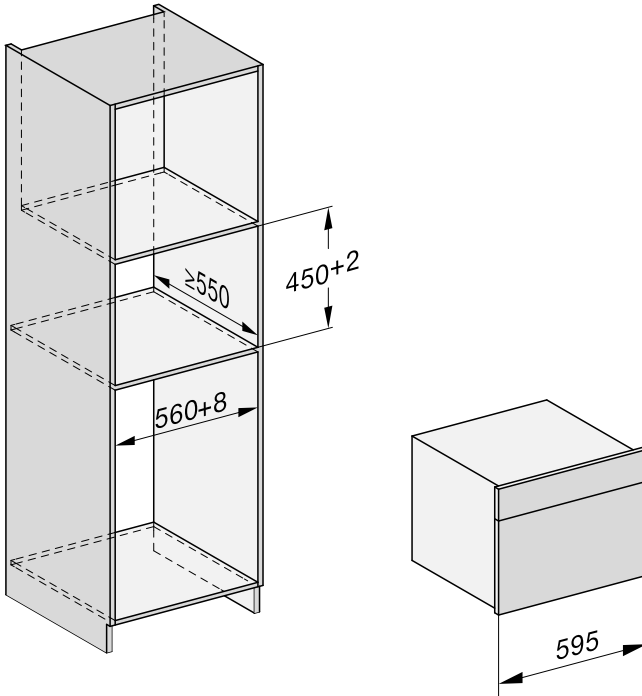

Installation

Installation in a base unit

The furniture housing unit must not have a back panel fitted behind the building-in niche.

If the steam oven is to be installed in a base unit underneath an electric or induction cooktop, please also observe the installation instructions for the cooktop as well as the building-in height required for the cooktop.

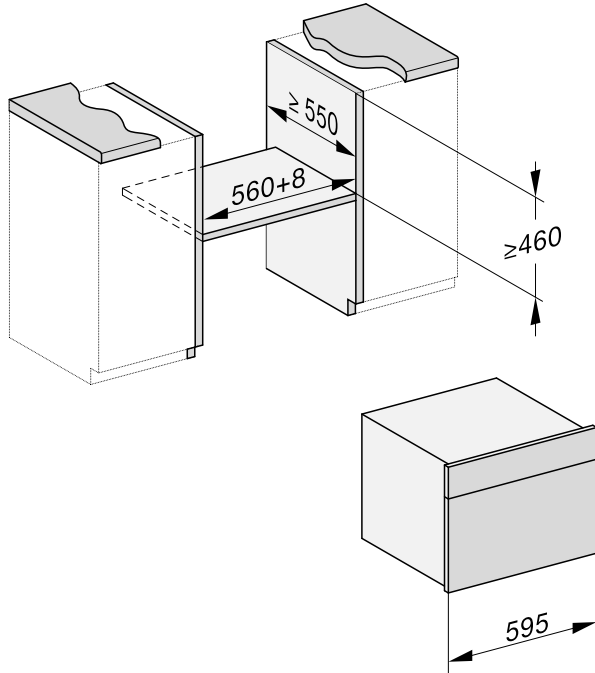

Side view

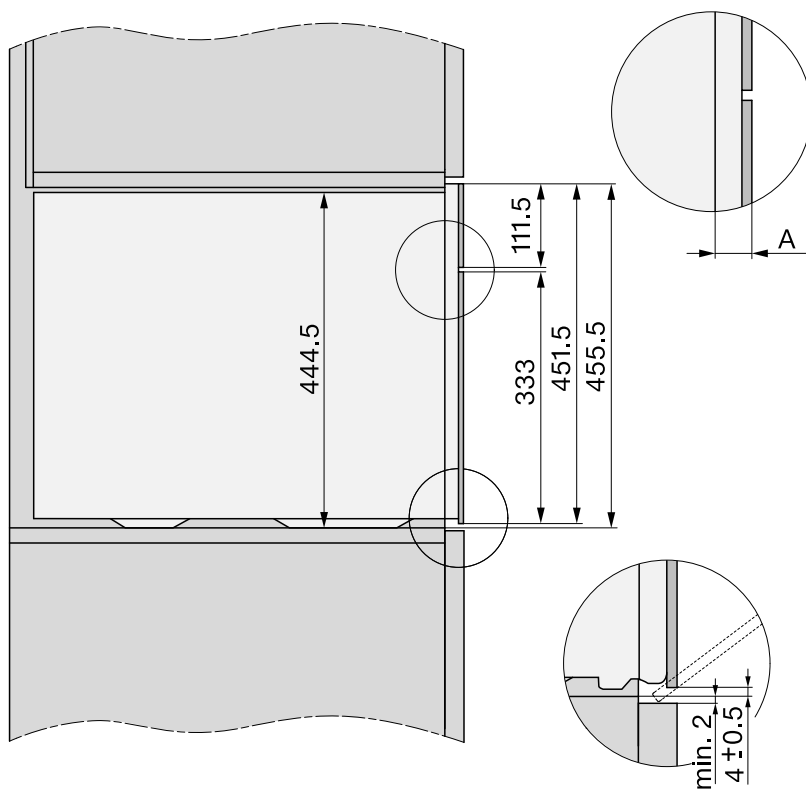

- A** Glass front: 22 mm
- Metal front: 23.3 mm

Installation

Connection and ventilation

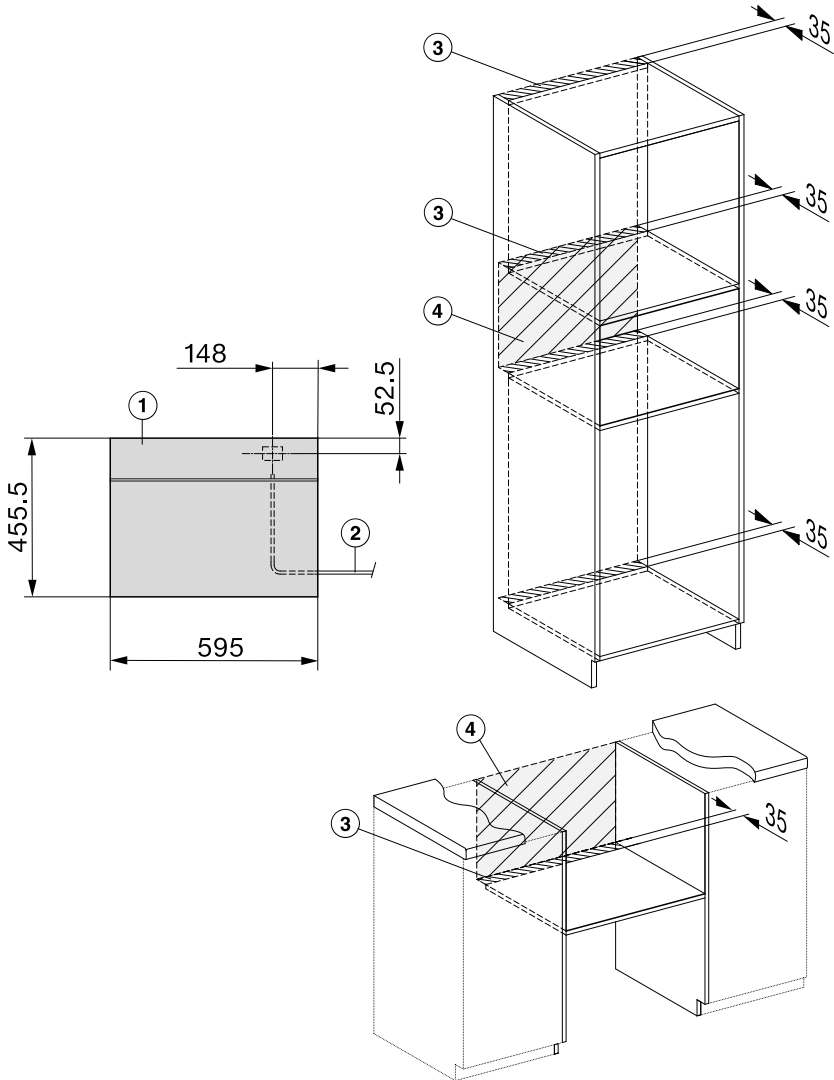

- ① Front view
- ② Mains connection cable, L = 2000 mm
- ③ Ventilation cut-out, min. 180 cm²
- ④ No connections permitted in this area

Installing the steam oven

- Connect the mains connection cable to the appliance.

Risk of damage from incorrect transportation.

Lifting the steam oven by the door handle could cause damage to the door.

Use the handle cut-outs on the side of the casing to lift the appliance.

The steam generator may malfunction if the steam oven is not on a level surface.

The maximum deviation from the horizontal that can be tolerated is 2°.

- Push the steam oven into the housing unit and align it.
When doing so, make sure that the mains connection cable does not get trapped or damaged.
- Open the door.

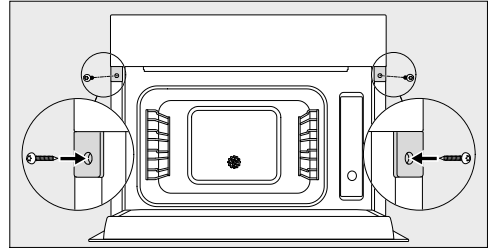

- Secure the steam oven to the side walls of the unit using the wood screws supplied (3.5 x 25 mm).
- Connect the appliance to the mains electricity supply.
- Check the appliance for correct function in accordance with the operating instructions.

Installation

Electrical connection

The steam oven is supplied with a mains connection cable with moulded plug ready for connection to a suitable earthed socket.

The socket should be easily accessible after the steam oven has been installed. If the socket is not easily accessible, ensure that a suitable means of disconnection is provided on the installation side for each pole.



Risk of fire from overheating.

Connecting the steam oven to multi-socket adapters or extension cables can overload the cables.

For safety reasons, do not use an extension cable or multi-socket adapter.

Risk of damage from incorrect connection. Incorrect installation, maintenance and repairs can be dangerous to users.

Miele cannot be held liable for damage or injury (e.g. electric shock) caused by unauthorised installation, maintenance or repair work, or by an inadequate or faulty on-site earthing system.

All electrical work must be carried out by a suitably qualified and competent person in strict accordance with national and local safety regulations.

For safety reasons, we recommend using a suitable residual current device (RCD) in the relevant electrical installation for connecting the steam oven.

If the mains connection cable is damaged, it must only be replaced with a specific mains connection cable of the same type (available from Miele). For safety reasons, such replacement may only be carried out by a suitably qualified and competent electrician or a Miele authorised service technician, in order to avoid a hazard.

The data plate indicates the nominal power consumption and the connection data. Compare this information with the data of the on-site electrical connection. If in any doubt, consult a qualified electrician.

Temporary or permanent operation with a self-sufficient or non-mains synchronous energy supply system (e.g. isolated networks, back-up systems) is possible. A requirement for the operation is that the energy supply system complies with all current local and national requirements that apply to stand-alone, solar and/or battery systems.

The protective measures provided in the domestic installation and in this Miele product must also be assured in their function and operation in isolated operation or in non-mains synchronous operation, or replaced with equivalent measures in the installation.

Miele Australia Pty. Ltd.

ACN 005 635 398

ABN 96 005 635 398

Level 4, 141 Camberwell Road
Hawthorn East, VIC 3123

1300 464 353 (1300 4 MIELE)

info@miele.com.au

www.miele.com.au

Miele New Zealand Limited

IRD 98 463 631

8 College Hill
Freemans Bay, Auckland 1011

0800 464 353 (0800 4 MIELE)

customercare@miele.co.nz

www.miele.co.nz

Miele Global Headquarters

Germany

Miele & Cie. KG

Carl-Miele-Straße 29

33332 Gütersloh

Federal Republic of Germany

DG 2740, DG 2840

en-AU, NZ

M.-Nr. 11 232 260 / 06 / 002