

THE BENCHMARK MACHINES



PDR 522 ROP | 50 lbs. PERFORMANCE

Features

- M Select ROP residual moisture control
- Short program cycles
- Patented Honeycomb Drum
- PerfectDry system – residual moisture sensors
- Intelligent dryers – gentle and uniform
- Perfect anti-crease
- Economical and efficient
- LAN/WiFi capable (accessory required)

OPL ON-PREMISE LAUNDRY



Gas Heating



Steam Heating



Up to **7** Years Warranty

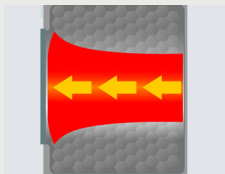

Axial airflow

For perfect drying results, air is passed through the drum according to the principle of longitudinal air flow.

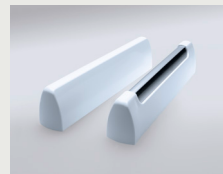

SoftLift drum ribs ensure gentle fabric care

The SoftLift drum ribs allow laundry to be dried gently and evenly.

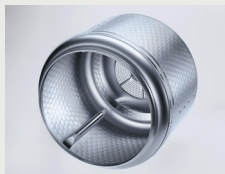

Honeycomb Drum

Less folding, easy finishing: laundry is dried very gently and evenly in the Honeycomb Drum.



Large fluff filter

The very large filter surface is particularly easy to clean.

Model	Heat Type	Electrical Specification Voltage/Hz/Phase (Amp)	Color	Material No.	Article No.
PDR 522 ROP	Gas	208, 240/60/1 (2 x 15 A)	Iron Grey	12012260	52522016NAM
PDR 522 ROP	Gas	208, 240/60/1 (2 x 15 A)	Stainless Steel	12012250	52522015NAM
PDR 522 ROP	Steam	208, 240/60/1 (2 x 15 A)	Iron Grey	12012270	52522018NAM

Specifications

Capacity	50 lbs. (22.5 kg)
Cylinder Diameter	20 1/2 in. (520 mm)
Cylinder Depth	29 3/16 in. (742 mm)
Cylinder Volume	14.1 cu.ft. (400 l)
Machine Dimensions (WxDxH)	35 11/16 x 45 13/16 x 55 1/8 in. (906 x 1,164 x 1,400 mm)
Door Opening	20 1/2 in. (520 mm)
Floor to Door	23 7/16 in. (595 mm)
Reversible Door	Yes
Shipping Dimensions (WxDxH)	42 15/16 x 49 3/8 x 60 1/16 in. (1,090 x 1,254 x 1,526 mm)
Net Weight Gas Steam	450 lbs. (204 kg) 512 lbs. (232 kg)
Crated Weight Gas Steam	481 lbs. (218 kg) 543 lbs. (246 kg)
Min. Recommended Distance Between Machines	13/16 in. (20 mm)
Agency Approvals	Intertek

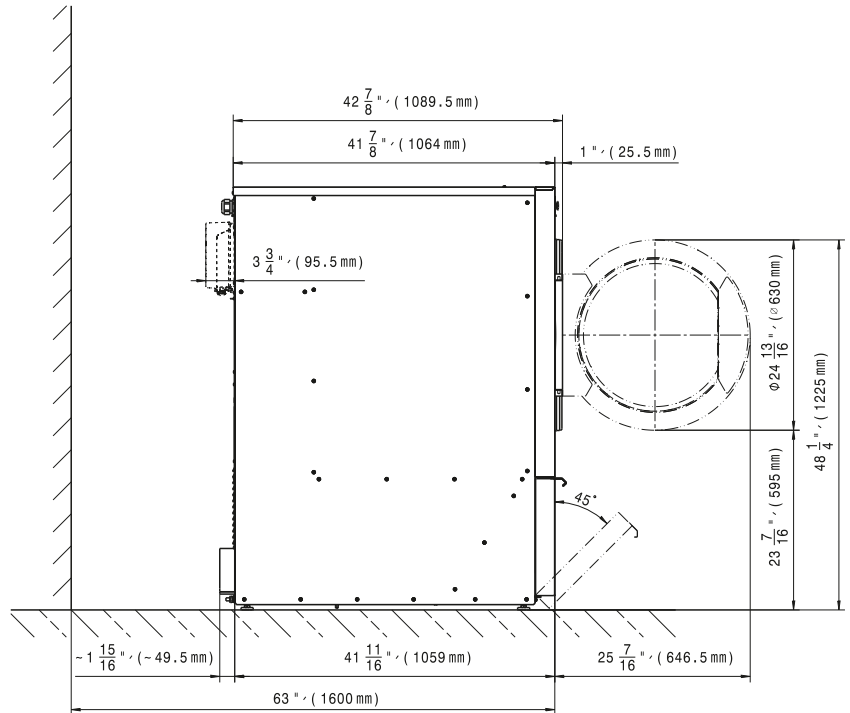
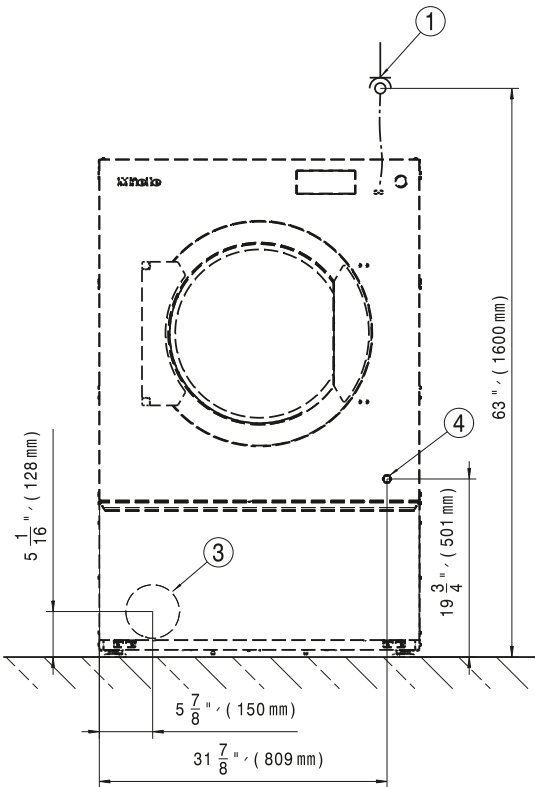
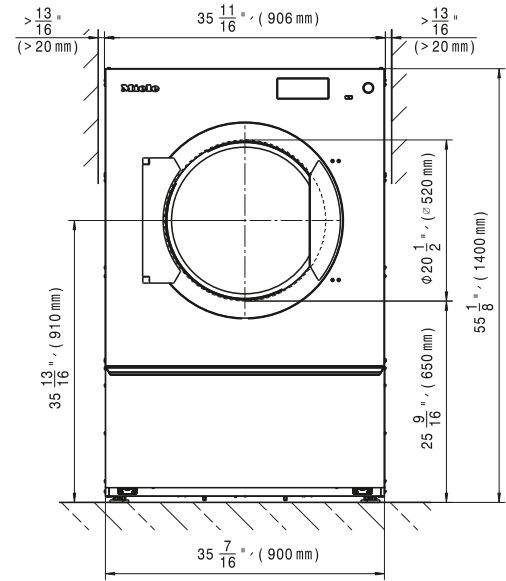

Heating	Voltage (Voltage/Hz/Phase)	Wire	Circuit Breaker Amps	Running Amps	Total Power (kW)
Gas	208, 240/60/1	2 Wire + Ground	15	7	1
Steam	208, 240/60/1	2 Wire + Ground	15	7	1

Specifications subject to change without notice or obligation. Contact Miele USA at (800) 991-9380 or Miele Canada at (888) 325-3957 for dimensions not shown or for clarification.