

THE BENCHMARK MACHINES



PDR 928 | 60 lbs. PERFORMANCE PLUS

Features

- Programmable controls
- Short program cycles
- Patented Honeycomb Drum
- PerfectDry system – residual moisture sensors
- Intelligent dryers – gentle and uniform
- Perfect anti-crease
- Economical and efficient
- LAN/WiFi capable (accessory required)

OPL ON-PREMISE LAUNDRY



Steam Indirect



Electric Heating



Up to **7** Years Warranty

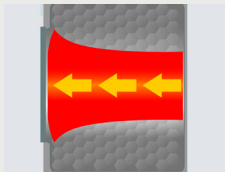

Axial airflow

For perfect drying results, air is passed through the drum according to the principle of longitudinal air flow.

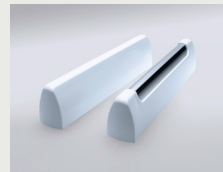

SoftLift drum ribs ensure gentle fabric care

The SoftLift drum ribs allow laundry to be dried gently and evenly.



Honeycomb Drum

Less folding, easy finishing: laundry is dried very gently and evenly in the Honeycomb Drum.



Large fluff filter

The very large filter surface is particularly easy to clean.

Model	Heat Type	Electrical Specification Voltage/Hz/Phase (Amp)	Color	Material No.	Article No.
PDR 928	Steam	208, 240/60/1 (2 x 15 A)	Iron Grey	12012330	52928021NAM
PDR 928	Steam	208, 240/60/1 (2 x 15 A)	Stainless Steel	12012320	52928020NAM
PDR 928	Electric	208, 240/60/3 (3 x 100 A)	Stainless Steel	12012380	52928022NAM
PDR 928	Electric	440, 480/60/3 (3 x 60 A)	Stainless Steel	12012390	52928024NAM

Specifications

Capacity	60 lbs. (27 kg)
Cylinder Diameter	43 ^{5/16} in. (1,100 mm)
Cylinder Depth	22 ^{1/16} in. (561 mm)
Cylinder Volume	17.66 cu.ft. (500 l)
Machine Dimensions (WxDxH)	47 ^{1/2} x 40 ^{1/8} x 64 ^{9/16} in. (1,206 x 1,019 x 1,640 mm)
Door Opening	20 ^{1/2} in. (520 mm)
Floor to Door	27 ^{15/16} in. (710 mm)
Reversible Door	Yes
Shipping Dimensions (WxDxH)	54 ^{3/4} x 43 ^{5/8} x 69 ^{1/2} in. (1,390 x 1,108 x 1,766 mm)
Net Weight EL Steam	536 lbs. (243 kg) 621 lbs. (281 kg)
Crated Weight EL Steam	569 lbs. (258 kg) 653 lbs. (296 kg)
Steam Inlets (Steam version)	2 x 1/2 in. (51 x 13 mm)
Recommended Water Pressure	87-145 psi
Min. Recommended Distance Between Machines	13/16 in. (20 mm)
Agency Approvals	Intertek

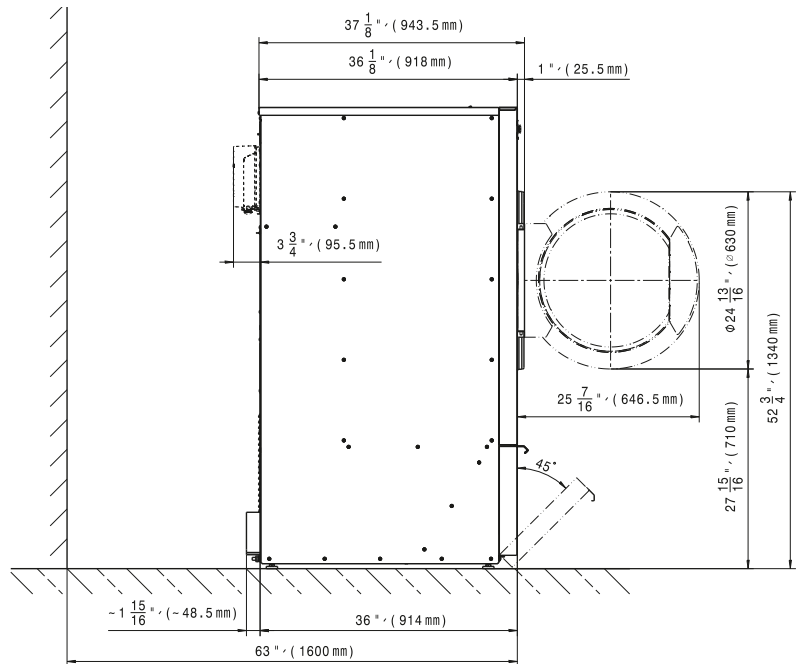
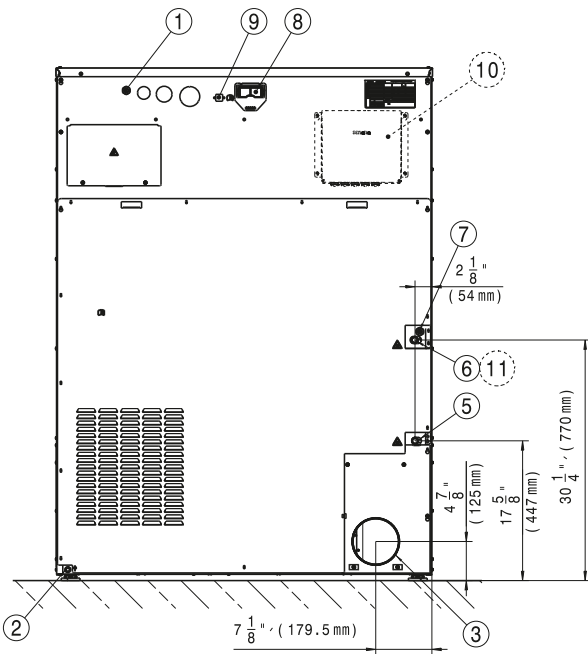
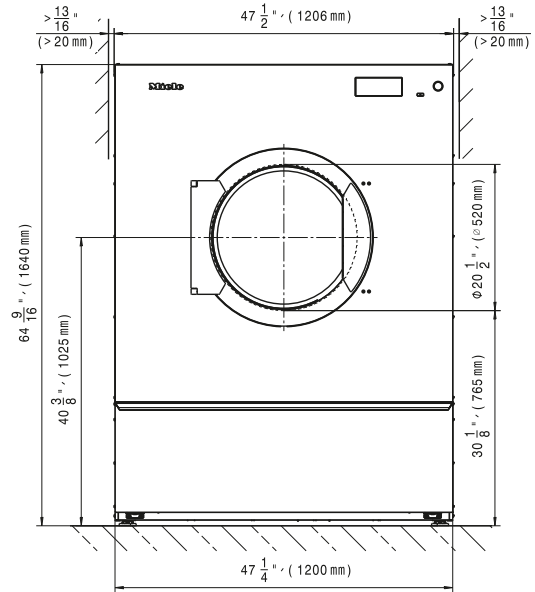

Heating	Voltage (Voltage/Hz/Phase)	Wire	Circuit Breaker Amps	Running Amps	Total Power (kW)
Steam	208, 240/60/1	2 Wire + Ground	15	7	1
Electric	208, 240/60/3	3 Wire + Ground	100	77	30.4
Electric	440, 480/60/3	3 Wire + Ground	60	41.4	32.8

Specifications subject to change without notice or obligation.
Contact Miele USA at (800) 991-9380 or Miele Canada at
(888) 325-3957 for dimensions not shown or for clarification.