

# Installation plan

PFD 102 i  
PFD 103 SCi

# Contents

---

<b>Installation notes</b> .....	3
Installation requirements .....	3
Environmental requirements .....	3
Electrical connection .....	3
Water connection .....	4
<b>Appliance dimensions and installation dimensions</b> .....	5
Appliance dimensions and installation drawings .....	5
Front panel dimensions .....	5
<b>Connections</b> .....	6
Connections on the back of the appliance .....	6
On-site connections .....	6
External dispensing .....	7
<b>Technical data</b> .....	8
Dimensions and weights .....	8
Emission levels .....	8
Electrical connection .....	9
Water inlet .....	9
Drain .....	10
Operating conditions .....	10
Storage and transportation conditions .....	10

## Installation notes

For safe installation and commissioning of the dishwasher please read the installation plan, the service documentation, the installation sheet and the operating instructions.

This installation plan includes the dimensions of the appliance, the technical data and the requirements to be met on site for the installation of the dishwasher.

### Installation requirements

This dishwasher must only be installed and commissioned by the Miele Customer Service Department, a Miele authorised dealer or a suitably qualified specialist.

Installation should only be performed in accordance with valid regulations, relevant standards and health and safety codes.

### Environmental requirements

Condensate can build up in the area surrounding the dishwasher. Any furniture and fittings in the room must therefore be suitable for purpose.

Vapour barrier film for built-in appliances

The vapour barrier film supplied protects the worktop from damage caused by steam when the door is opened. Attach the vapour barrier film above the door, underneath the worktop.

### Electrical connection

All work on the electrical connection must be carried out by the Miele Customer Service Department, an authorised Miele dealer or a qualified electrician.

Plug connection

The dishwasher should be connected to the electricity supply via a socket.

Hard-wired

If the dishwasher is hard-wired to the power supply, a power switch capable of disconnecting the dishwasher at all poles must be installed on site. This power switch must have a contact gap of at least 3 mm.

The socket and the power switch must be accessible after the appliance has been installed. An electrical safety test must be carried out after installation and after any servicing work.  
The mains connection cable must be laid protected from the risk of thermal damage.

Residual current device (RCD)

For increased safety, it is recommended to protect the dishwasher with a residual current device (RCD) with a trip current of 30 mA.

Equipotential bonding

There is a screw connection point for equipotential bonding at the back of the dishwasher.  
Equipotential bonding should be carried out if possible on site.

## Installation notes

---

### Water connection

The dishwasher must only be connected to fully vented pipework. A brief increase in the water pressure can damage components of the dishwasher.

### Water inlet

The quality of the incoming water must correspond to the drinking water specification of the country in which the dishwasher is being operated.

The dishwasher must be connected to the water supply in strict accordance with current local and national water authority regulations. It can be connected to cold or hot water supplies. Connecting the dishwasher to a hot water supply will reduce programme running times. For short programme running times, a water pressure of at least 200 kPa is also required.

If a stopcock is not available, only a qualified installer may connect the dishwasher to the drinking water supply.

The stopcock should remain accessible once the dishwasher has been installed so that the water supply can be shut off whenever the appliance is not in use.

### Drain

The dishwasher drain hose should be connected to a separate on-site drainage system for the dishwasher only. If a separate connection is not available, we recommend connecting the hose to a dual-chamber siphon.

If the hose is to be fitted directly to the drainage system on site, use the hose clip supplied with the dishwasher.

The on-site connector for the drain hose can be adapted to different hose diameters. If the connector extends more than 30 mm into the drain hose, it must be shortened. Otherwise, the drain hose can become blocked.

Lay the drain hose so that it does not kink and is not being subjected to pressure or tension.

If the on-site drain connection is situated lower than the guide path for the lower basket rollers in the open door, a siphoning effect during a programme can cause the wash cabinet to empty itself of water.

In this case, lay the drain hose with a bend in it so that its highest point is at least level with the guide path for the lower basket rollers. For AU, NZ the drain should be connected in accordance with AS/NZS 3500.2.

### External dispensing

An external dispensing module for liquid cleaning agents can be connected to the back of the dishwasher.

The dispensing module is available as an optional accessory and is supplied with installation instructions.

# Appliance dimensions and installation dimensions

## Appliance dimensions and installation drawings

**PFD 102 i**

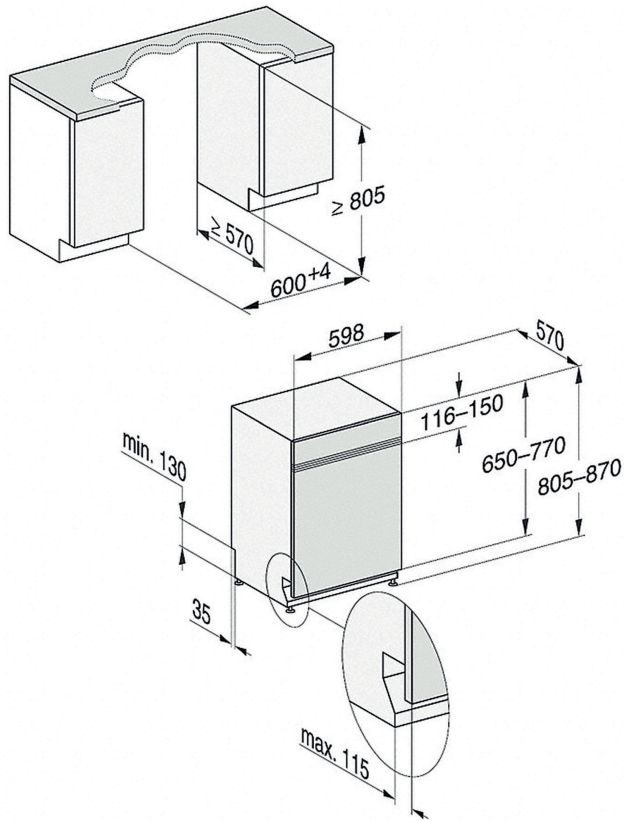

**PFD 103 SCi**

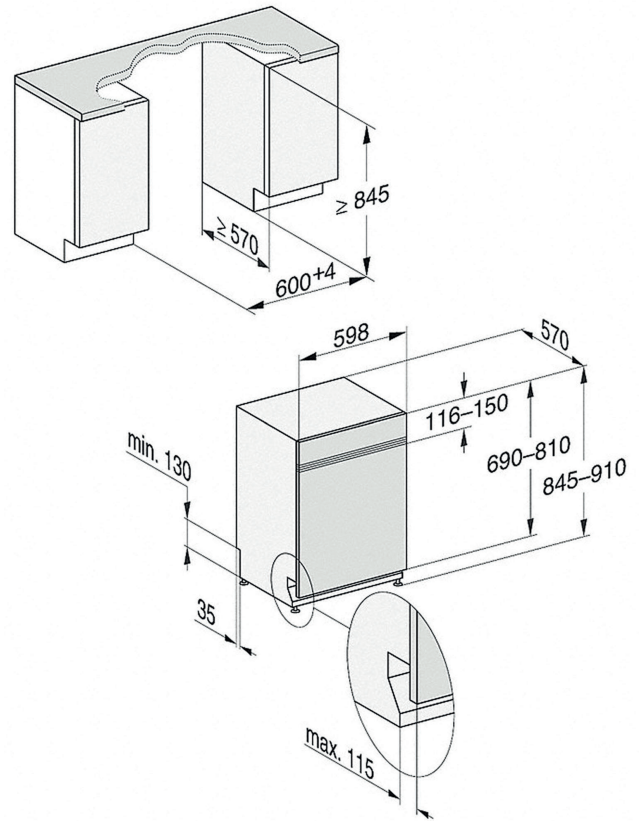

Appliance type		PFD 102 i	PFD 103 SCi
<b>Front panel dimensions</b>			
Length	[mm]	500-654	540-694
Thickness	[mm]	16-20	16-20
Weight	[kg]	4-11	4-11

# Connections

## Connections on the back of the appliance

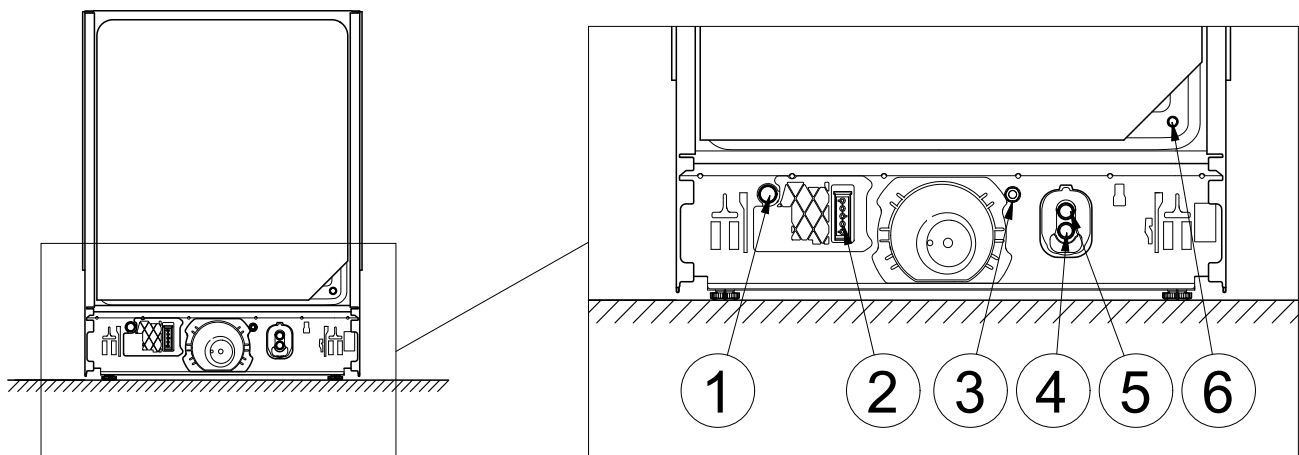

## On-site connections

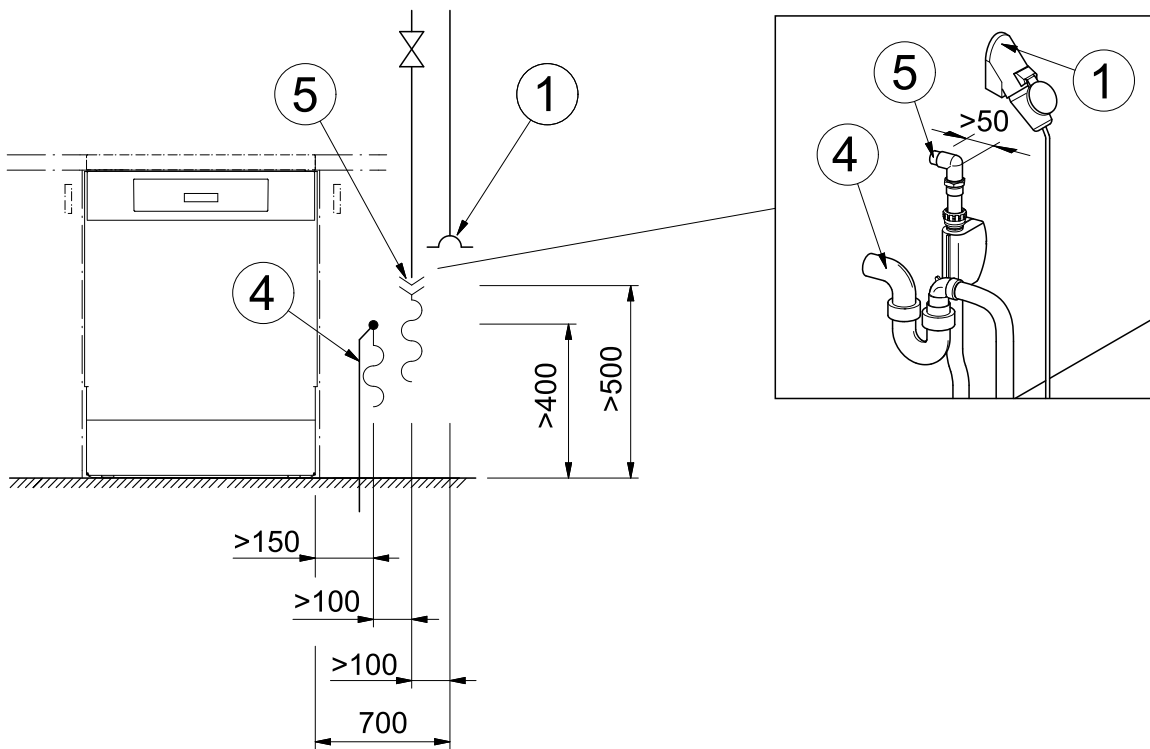

- ① Electrical connection
- ② External dispensing, power supply connection
- ③ Equipotential bonding
- ④ Waste water
- ⑤ Cold or hot water
- ⑥ External dispensing, connection for dispensing hose sealed with a blind stopper\*

\* the dispenser connector is supplied with the dispensing module

## External dispensing

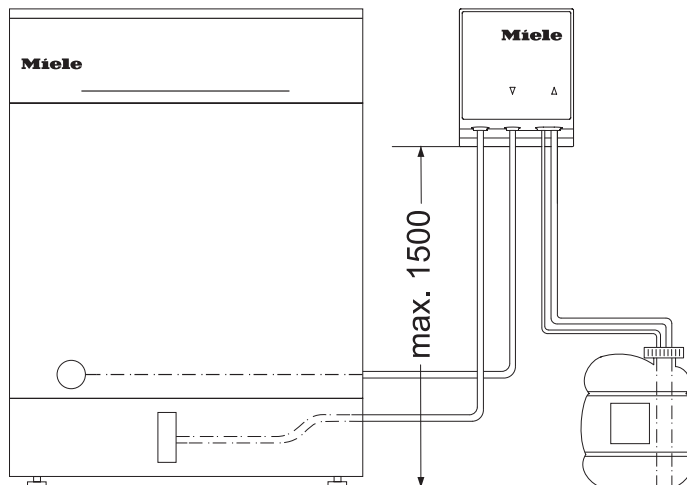

Max. delivery head	[m]	1.5
Length of dispenser hose, DOS module to suction lance	[m]	1.8
Length of dispenser hose, back of appliance to DOS module	[m]	2.8
Length of power cable, back of appliance to DOS module	[m]	2.8

Place the container on the floor next to the cleaning machine or in an adjacent cabinet. The container must not be placed on top of or above the cleaning machine.

## Technical data

---

Appliance type		PFD 102 i	PFD 103 Sci
----------------	--	-----------	-------------

### Dimensions and weights

Height	[mm]	805	845
Height adjustment	[mm]	65	65
Width	[mm]	598	598
Depth	[mm]	570	570
Depth with door open	[mm]	1165	1205
Max. plinth return	[mm]	115	115
Weight	[kg]	42	52
Max. floor load	[N]	1000	1000

### Emission levels

Sound power level	[dB(A) re 1 pW]	46	45
Sound pressure level in the workplace	[dB(A)]	34.1	32.5



### Electrical connection

#### Standard electrical connection PFD 102 i

Voltage		AC 230V
Frequency	[Hz]	50
Fuse rating	[A]	32
Plug		-
Power cable length	[m]	1.7
Power cable cross-section	[mm <sup>2</sup> ]	3x4
Heat output	[kW]	6.1
Total rated load	[kW]	6.3

#### Standard electrical connection , Possible voltage variant PFD 102 i

Voltage *		AC 230V
Frequency	[Hz]	50
Fuse rating	[A]	13
Plug		+
Power cable ** length	[m]	1.7
Power cable cross-section	[mm <sup>2</sup> ]	3x1.5
Heat output	[kW]	1.9
Total rated load	[kW]	2.1

\* Programme running times are longer with this voltage variant

\*\* Optional accessory

### Water inlet

Max. water temperature	[°C]	60
Max. water hardness	[mmol/l]	6.5
Max. water hardness	[°dH]	36
Water connection pressure	[kPa]	100 – 1000
On-site threaded union (flat seal)	[inches]	3/4
Connection hose length	[m]	1.5
Connection hose extension *	[m]	1.5

\* Optional accessory

## Technical data

---

### Drain

Max. water temperature	[°C]	82
Drain hose length	[m]	1.5
Max. drain hose length	[m]	4
Max. delivery head	[m]	1
Max. transient flow rate	[l/min]	10
Hose inner diameter	[mm]	22
On-site hose sleeve (∅ x length)	[mm]	22 x 30

### Operating conditions

Ambient temperature	[°C]	+5 – +40
Relative humidity: Up to 31 °C, maximum	[%]	80
Linear decreasing to 40 °C	[%]	50
Max. altitude above sea level up to	[m]	4000

### Storage and transportation conditions

Ambient temperature	[°C]	-20 – +60
Relative humidity	[%]	10–85
Air pressure	[hPa]	500–1060

### Min. site access dimensions including transport pallet

Height	[mm]	970
Width	[mm]	670
Depth	[mm]	670



## United Kingdom

Miele Co. Ltd., Fairacres, Marcham Road  
Abingdon, Oxon, OX14 1TW  
Professional Sales, Tel: 0845 365 6608  
E-mail: professional@miele.co.uk  
Internet: www.miele.co.uk/professional

## Australia

Miele Australia Pty. Ltd.  
ACN 005 635 398, ABN 96 005 635 398  
Level 4, 141 Camberwell Road, Hawthorn East, VIC 3123  
Tel: 1300 731 411  
Internet: www.miele.com.au/professional  
E-mail: professional.sales@miele.com.au

## China Mainland

Miele Electrical Appliances Co., Ltd.  
1-3 Floor, No. 82 Shi Men Yi Road  
Jing' an District, 200040 Shanghai, PRC  
Tel: +86 21 6157 3500, Fax: +86 21 6157 3511  
E-mail: info@miele.cn, Internet: www.miele.cn

## Hong Kong, China

Miele (Hong Kong) Ltd.  
41/F - 4101, Manhattan Place  
23 Wang Tai Road, Kowloon Bay, Hong Kong  
Tel: (852) 2610 1025, Fax: (852) 3579 1404  
Email: customerservices@miele.com.hk  
Website: www.miele.hk

## India

Miele India Pvt. Ltd.  
1st Floor, Copia Corporate Suites,  
Commercial Plot 9, Mathura Road, Jasola,  
New Delhi - 110025  
E-mail: customercare@miele.in, Website: www.miele.in

## Ireland

Miele Ireland Ltd.  
2024 Bianconi Ave., Citywest Business Campus, Dublin 24  
Tel: (01) 461 07 10, Fax: (01) 461 07 97  
E-Mail: info@miele.ie, Internet: www.miele.ie

## Malaysia

Miele Sdn Bhd  
Suite 12-2, Level 12  
Menara Sapura Kencana Petroleum  
Solaris Dutamas No. 1, Jalan Dutamas 1  
50480 Kuala Lumpur, Malaysia  
Phone: +603-6209-0288  
Fax: +603-6205-3768

## New Zealand

Miele New Zealand Limited  
IRD 98 463 631  
8 College Hill  
Freemans Bay, Auckland 1011, NZ  
Tel: 0800 464 353  
Internet: www.miele.com.au/professional  
E-mail: professional.sales@miele.com.au

## Singapore

Miele Pte. Ltd.  
29 Media Circle, #11-04 ALICE@Mediapolis  
Singapore 138565  
Tel: +65 6735 1191, Fax: +65 6735 1161  
E-Mail: info@miele.com.sg  
Internet: www.miele.sg

## South Africa

Miele (Pty) Ltd  
63 Peter Place, Bryanston 2194  
P.O. Box 69434, Bryanston 2021  
Tel: (011) 875 9000, Fax: (011) 875 9035  
E-mail: info@miele.co.za  
Internet: www.miele.co.za

## United Arab Emirates

Miele Appliances Ltd.  
Showroom 1, Eiffel 1 Building  
Sheikh Zayed Road, Umm Al Sheif  
P.O. Box 114782 - Dubai  
Tel. +971 4 3044 999, Fax. +971 4 3418 852  
800-MIELE (64353)  
E-Mail: info@miele.ae, Website: www.miele.ae



Manufacturer: Miele & Cie. KG  
Carl-Miele-Straße 29, 33332 Gütersloh, Germany