

Miele

Operating instructions



Cordless vacuum cleaner

AU, NZ

HS19

M.-Nr. 12 852 420

Contents

Warning and Safety instructions	4
Warning and safety notes for AP01/AP02/AP03 battery, LG01/LG02/LG04 charger, LS03/LS04 charger cradle (depending on the model)	7
Sustainability and environmental protection	12
Familiarisation	14
Guide to the appliance	14
Familiarisation	16
Vacuum cleaner configuration options.....	16
Accessories included	17
Accessories holder for the suction tube	17
3D4U	18
Battery charging state indicator (while charging).....	19
Commissioning	19
Assembling the vacuum cleaner	19
Separating components	19
General battery information.....	19
Inserting the battery	20
Charging the battery (without wall mounting)	20
Charging the battery (with wall mounting)	21
Wall mounting.....	21
Removing the battery	24
Charging the battery in the battery charger cradle.....	24
Operation	24
Switching on and off	24
Selecting the suction power level.....	25
Battery charging state indicator (while in use)	25
Self-standing function for short pauses in vacuuming	25
Good to know	26
Cleaning tips	26
Cleaning and care	26
Caring for the vacuum cleaner and accessories	26
Filter system.....	26
Using the ComfortClean self-cleaning function	27
Emptying the dust container	27
Cleaning the pre-filter and fine dust filter	28
Cleaning the dust container.....	30
Cleaning the Electrobrush/handheld brush (depending on model).....	30
Replacing the rechargeable battery	31
Troubleshooting	32

Contents

After sales service	33
Contact in case of malfunction	33
Warranty	33
Electrical connection	34
Optional accessories	34

Warning and Safety instructions

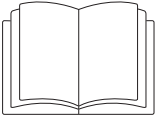

► It is essential to read these instructions.

This vacuum cleaner conforms to current safety requirements. Inappropriate use can lead to personal injury and damage to property.

Please read the operating instructions before using the vacuum cleaner and charging the battery for the first time. They contain important information on the safety, use, cleaning and care of the vacuum cleaner. This will prevent both personal injury and damage to the appliance.

In accordance with standard IEC 60335-1, Miele expressly and strongly advises that you read and follow the instructions in the “Commissioning” section as well as the warning and safety instructions.

Miele cannot be held liable for injury or damage caused by non-compliance with these instructions.

Keep these operating instructions in a safe place and pass them on to any future owner/operator.

Always switch the vacuum cleaner off when you have finished using it, before changing any accessories and before performing cleaning, care and troubleshooting. Use the On/Off switch on the handle to do this.

Correct application



- ▶ This vacuum cleaner is intended for cleaning flooring in domestic households and similar residential environments. This vacuum cleaner is not suitable for use on construction sites.
- ▶ This vacuum cleaner is not intended for outdoor use.
- ▶ This vacuum cleaner can be used for all normal cleaning of carpets, rugs and robust hard flooring.
- ▶ This vacuum cleaner is intended for use at altitudes of up to 4000 m above sea level.
- ▶ The vacuum cleaner must only be used to vacuum dry floor surfaces. Do not vacuum people or animals. Any other types of use, modifications or alterations are not permitted.
- ▶ The vacuum cleaner can only be used by people (including children) with reduced physical, sensory, or mental capabilities, or lack of experience or knowledge, if they are supervised whilst using it or have been shown how to use it in a safe way and understand and recognise the consequences of incorrect operation.

Safety with children

- ▶ Children under 8 years of age must be kept away from the vacuum cleaner unless they are constantly supervised.
- ▶ Children aged 8 and older may only use the vacuum cleaner without supervision if they have been shown how to use it in a safe manner. Children must be able to understand and recognise the possible dangers caused by incorrect operation.
- ▶ Children must not be allowed to clean or maintain the vacuum cleaner unsupervised.
- ▶ Please supervise children in the vicinity of the vacuum cleaner and do not let them play with it.
- ▶ Danger of suffocation. Packaging, e.g. plastic wrappings, must be kept out of the reach of babies and children. Whilst playing, children could become entangled in packaging or pull it over their head and suffocate.

Warning and Safety instructions

Technical safety

- ▶ The vacuum cleaner operates at 25.2 V.
It is classified as a class II appliance  and has a class III design. This appliance is supplied by a safety extra-low voltage (SELV) power source where the voltage is low enough to protect users from the risk of electrical shock. A class II charger is used for supplying power to charge the vacuum cleaner .
- ▶ Compare the connection data on the data plate of the charger (voltage and frequency) with that of the mains electricity supply. This data must match exactly. Without modifications, the charger is suitable for 50 Hz and 60 Hz.
- ▶ The mains electrical outlet must be fitted with an appropriate circuit breaker.
- ▶ The Miele Multi Floor XXL Electrobrush and the Miele Electro Compact handheld brush (varies according to the model) are additional motor-driven devices designed specially for this Miele vacuum cleaner. For safety reasons, the vacuum cleaner must not be used with a different Miele Electrobrush/handheld brush or an Electrobrush/handheld brush produced by another manufacturer.
- ▶ Check both the vacuum cleaner and all accessories supplied with it for any visible signs of damage before use. Do not use a damaged vacuum cleaner or damaged accessory.
- ▶ Before and during use, make sure that no coarse dirt or debris is/gets trapped in the bottom of the Multi Floor XXL Electrobrush or in the bottom of the Electro Compact handheld brush (supplied depending on model).
- ▶ Store the vacuum cleaner and all accessories at an ambient temperature between 0 °C and 45 °C.
- ▶ Repairs should only be undertaken by a Miele authorised service technician. Otherwise the warranty will be invalidated.
- ▶ Repairs and other work by unqualified persons can cause considerable danger to users.
- ▶ If the vacuum cleaner is to be stored unused for a long period, the battery should be removed.
- ▶ The supply terminals must not be short-circuited.

Correct use

- ▶ Do not use the vacuum cleaner without the dust container, pre-filter and fine dust filter fitted.
- ▶ Do not vacuum up anything which has been burning or is still glowing e.g. cigarettes, ashes or coal, whether glowing or apparently extinguished.
- ▶ Do not use the vacuum cleaner to vacuum up any water, liquid or damp dirt. Wait until any freshly cleaned or shampooed rugs or carpets are completely dry before attempting to vacuum.
- ▶ Do not use the vacuum cleaner to vacuum toner dust. Toner, such as that used in printers and photocopiers, can conduct electricity.
- ▶ Do not vacuum up any inflammable or combustible liquids or gases and do not vacuum in areas where such substances are stored.
- ▶ Never touch the Multi Floor XXL Electrobrush or Electro Compact handheld brush (varies according to the model) while it is rotating.
- ▶ Do not use the Multi Floor XXL Electrobrush or the Electro Compact handheld brush (varies according to the model) at head height.
- ▶ Do not vacuum at head height and do not let the suction get anywhere near a person's head.

Warning and safety notes for AP01/AP02/AP03 battery, LG01/LG02/LG04 charger, LS03/LS04 charger cradle (depending on the model)

Safety with children

- ▶ People (including children) with reduced physical, sensory or mental capabilities, or lack of experience or knowledge, who are unable to use the LG01/LG02/LG04 charger or LS03/LS04 charger cradle safely may only use this vacuum cleaner if they are supervised whilst using it or have been shown how to use it in a safe way and understand and recognise the consequences of incorrect operation.
- ▶ Keep the AP01/AP02/AP03 battery out of the reach of children.
- ▶ Children must be kept away from the LG01/LG02/LG04 charger and the LS03/LS04 charger cradle unless they are constantly supervised.
- ▶ Do not let children play with the chargers.

Warning and Safety instructions

Technical safety

► The AP01/AP02/AP03 battery, the LG01/LG02/LG04 charger and the LS03/LS04 charger cradle are designed for use with the Miele HS19 vacuum cleaner. For safety reasons, the vacuum cleaner must not be used with a battery, charger or charger cradle produced by another manufacturer.

► Only the LG01/**xx**, LG02/**xx** or LG04/**xx** charger supplied or the LS03/**xx** or LS04/**xx** charger cradle supplied or purchased as an optional accessory should be used to charge the AP01/AP02/AP03 battery.

xx stands for 01, 02, 03, 04, 05, 06, 07 or 08; these numbers identify the version of your LG01/LG02/LG04 charger and your LS03/LS04 charger cradle.

xx	LG01/LS03/LS04	LG02/LG04
01	AT, BE, BG, CH, CL, CZ, DE, DK, EE, ES, FI, FR, GR, HR, HU, IT, KZ, LT, LU, LV, NL, NO, PL, PT, RO, RS, RU, SE, SI, SK, TR, UA, ZA	AT, BE, BG, CH, CL, CZ, DE, DK, EE, ES, FI, FR, GR, HR, HU, IT, KZ, LT, LU, LV, NL, NO, PL, PT, RO, RS, RU, SE, SI, SK, TR, UA, ZA
02	AE, HK, IE, MY, SG, UK	AE, HK, IE, MY, SG
03	BR, CA, MX, US	BR, CA, JP, MX, US
04	AU, NZ	AU, NZ
05	CN	CN
06	KR	KR
07	JP	UK
08	IN	

► If you are using a mains plug adapter, make sure that it is approved for continuous operation.

Warning and Safety instructions

▶ Temporary or permanent operation on an autonomous power supply system or a power supply system that is not synchronised with the mains power supply (e.g. island networks, back-up systems) is possible. A prerequisite for operation is that the power supply system complies with the specifications of EN 50160 or an equivalent standard.

The function and operation of the protective measures provided in the domestic electrical installation and in this Miele product must also be maintained in isolated operation or in operation that is not synchronised with the mains power supply, or these measures must be replaced by equivalent measures in the installation. As described, for example, in the current version of BS OHSAS 18001–2 ISO 45001.

▶ Charge and use the AP01/AP02/AP03 battery at an ambient temperature between 0 °C and 45 °C.

Using the AP01/AP02/AP03 battery outside of this ambient temperature range will limit its performance.

▶ Stop using the AP01/AP02/AP03 battery immediately if you notice an unusual smell from it, if liquid is leaking from it, if it is significantly overheating or if it is discoloured or deformed. Dispose of the AP01/AP02/AP03 battery immediately (see safety note “Disposing of the AP01/AP02/AP03 battery” at the end of the following section “Correct use”, as well as “Sustainability and environmental protection” – “Disposing of old batteries”).

▶ Batteries will deplete over time. They can then leak corrosive fluids. Avoid contact with the eyes and skin. In the event of contact, rinse thoroughly with water and seek medical advice.

▶ To deal with leaking batteries, refer to the Safety Data Sheet (contact Miele to request a copy).

▶ The AP01/AP02/AP03 lithium-ion battery is subject to the dangerous goods legislation. The user is permitted to transport the AP01/AP02/AP03 battery by road without having to observe any further requirements. Please contact the Miele Customer Service Department before sending the AP01/AP02/AP03 battery. Only send AP01/AP02/AP03 batteries that are undamaged and have been fully run down. Insulate the metal contacts with adhesive tape to prevent short circuits. Pack the AP01/AP02/AP03 battery in such a way that it is not able to move around inside the packaging.

Warning and Safety instructions

Correct use

- ▶ Do not drop or throw the AP01/AP02/AP03 battery. For safety reasons, do not continue to use an AP01/AP02/AP03 battery which has been damaged.
- ▶ Keep the AP01/AP02/AP03 battery away from naked flames or other heat sources. Do not heat the AP01/AP02/AP03 battery. Do not expose the rechargeable battery to direct sunlight.
- ▶ Do not dismantle the AP01/AP02/AP03 battery.
- ▶ Do not cause a short circuit by bridging the contacts of the AP01/AP02/AP03 battery, either unintentionally or deliberately.
- ▶ Do not allow the AP01/AP02/AP03 battery to come into contact with liquids.
- ▶ Disconnect the LG01/LG02/LG04 charger and the LS03/LS04 charger cradle from the power supply if these parts are not to be used for a longer period of time.
- ▶ The rechargeable battery must be removed before the appliance is scrapped.
- ▶ Disposing of the AP01/AP02/AP03 battery: remove the AP01/AP02/AP03 battery from the vacuum cleaner. Insulate the metal contacts with adhesive tape to prevent short circuits. Dispose of the AP01/AP02/AP03 battery in a municipal recycling facility. Do not dispose of the AP01/AP02/AP03 battery with your household waste.

Cleaning

- ▶ Do not immerse the vacuum cleaner or any accessories supplied with it in water.
- ▶ The Multi Floor XXL Electrobrush and the Electro Compact hand-held brush (depending on the model), the PowerUnit, the suction tube and the Comfort handle contain electrical wires. The plug connectors must not come into contact with water. Danger of electric shock. They should only be cleaned with a dry cloth.
- ▶ Clean the vacuum cleaner and accessories only with a dry or slightly damp cloth when disconnected from the power supply. Exception:
 - Dust container: empty the dust container and remove the pre-filter. Clean the dust container using water and mild washing-up liquid only. Then dry the dust container carefully. Replace the pre-filter in the dust container.

Accessories and spare parts

- ▶ Only use genuine accessories with the Miele logo on the packaging. The manufacturer cannot otherwise guarantee the safety of the product.
- ▶ Miele can only guarantee the safety of the appliance when genuine Miele replacement parts are used. Faulty components must only be replaced with genuine Miele replacement parts.
- ▶ Miele will guarantee to supply functional spare parts for a minimum of 10 years and up to 15 years following the discontinuation of your vacuum cleaner.

Transport

- ▶ The packaging material protects the vacuum cleaner from transport damage. We recommend you keep the packaging for transport purposes.

Sustainability and environmental protection

Disposing of the packaging material

The packaging material is used for handling and protects the appliance from transport damage. The packaging material used is selected from materials which are environmentally friendly for disposal and can generally be recycled.

Recycling the packaging material reduces the use of raw materials. Use material-specific collection points for valuable materials and take advantage of return options.

We recommend you keep the packaging material for transport purposes.

Disposing of your old appliance

Before disposing of your old appliance, remove the fine dust filter and dispose of it with your household waste.

Electrical and electronic appliances contain many valuable materials. They also contain certain materials, compounds, and components which were essential for their correct functioning and safety. These could be hazardous to human health and to the environment if disposed of with household waste or if handled incorrectly. Please do not, therefore, dispose of your old appliance with your household waste.



Please dispose of it at your local community waste collection/recycling centre for electrical and electronic appliances, or contact Miele. You should remove any old batteries which are not securely enclosed by the appliance. These must be taken to a suitable collection point where they can be handed in free of charge. Please ensure that your old appliance poses no risk to children while being stored for disposal.

Disposing of old batteries and rechargeable batteries

In many cases, electrical and electronic appliances contain batteries and rechargeable batteries which must not be disposed of with household waste after use. You should remove any removable batteries or rechargeable batteries and dispose of them immediately in a suitable recycling box for batteries. Insulate the metal contacts with adhesive tape to prevent short circuits.

 Batteries and rechargeable batteries contain substances which can be harmful to human health and the environment and should be kept out of the reach of children. Even flat batteries can still be dangerous. If you suspect a child has swallowed a battery, seek medical advice immediately.

The labeling on the battery and rechargeable battery will provide further information. A crossed out bin means that the battery or rechargeable battery must on no account be disposed of with your household waste. We are also required to inform you that a crossed out bin, which also has one or more chemical symbols below it, indicates that the battery or rechargeable battery contains lead (Pb), cadmium (Cd) and/or mercury (Hg).



Old batteries and rechargeable batteries contain important raw materials which can be recycled. Disposing of batteries and rechargeable batteries separately makes them easier to handle and recycle.

Familiarisation

Guide to the appliance

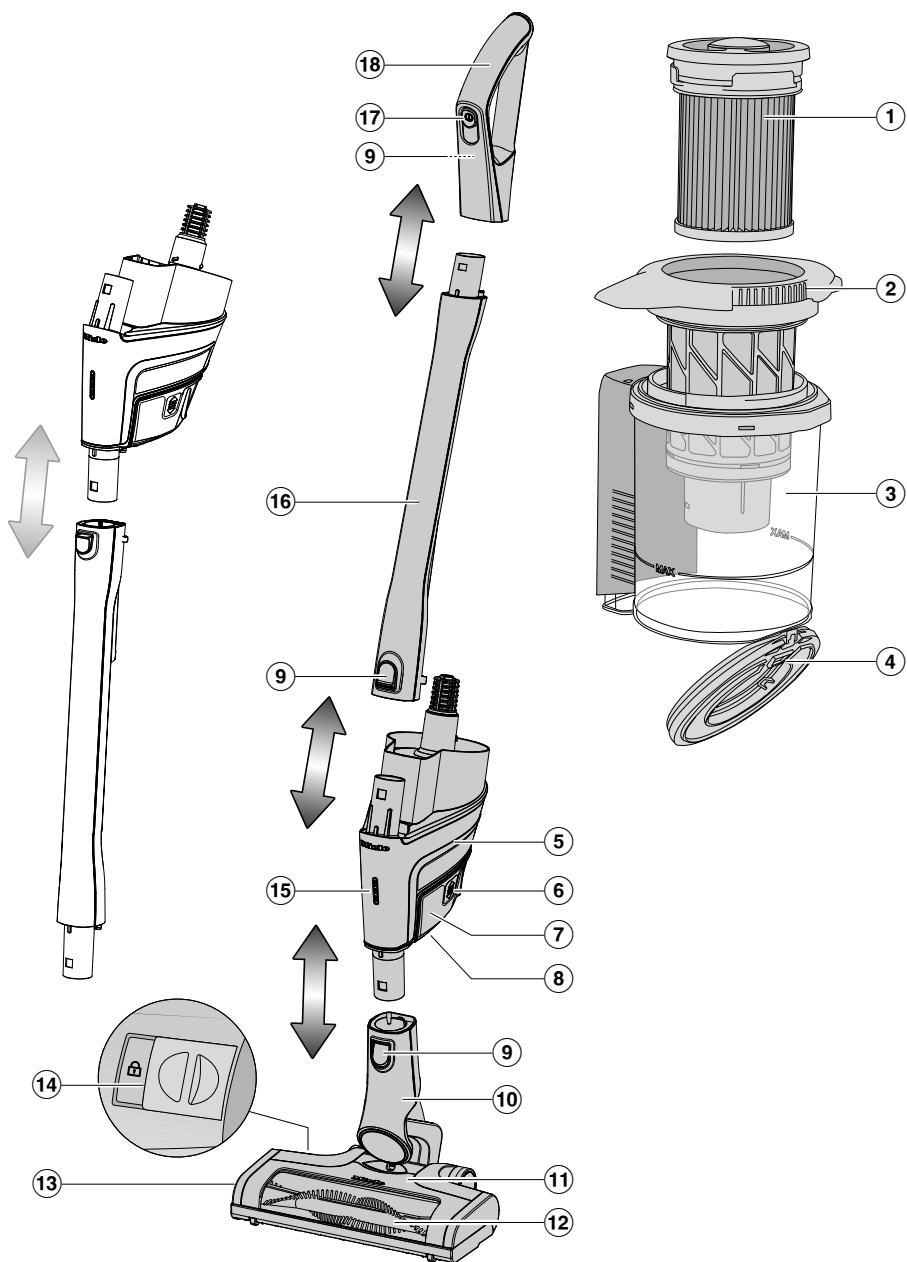

- ① Fine dust filter (HX-FSF-2)
- ② Pre-filter
- ③ Dust container
- ④ Dust container flap
- ⑤ PowerUnit with a connection at the bottom for the battery, a connector at the bottom for the suction tube and electrobrush, and a connector at the top for the suction tube and handle
- ⑥ Release buttons for battery (on both sides of the battery)
- ⑦ AP01/AP02/AP03 lithium-ion battery (HX-LA)
- ⑧ Charging socket (at the bottom of the battery)
- ⑨ Release buttons (on the handle at the back)
- ⑩ Electrobrush connector
- ⑪ Electrobrush Multi Floor XXL (some models feature BrilliantLight lighting)
- ⑫ Removable roller brush
- ⑬ Flap
- ⑭ Release catch for opening the electrobrush
- ⑮ Rechargeable battery status indicator
- ⑯ Suction tube
- ⑰ On/Off switch with suction power selector
- ⑱ Handle

Familiarisation

Follow the flooring manufacturer's cleaning and care instructions.

Miele offers a range of suitable accessories for many special applications (see "Optional accessories").

Vacuum cleaner configuration options

You can assemble the vacuum cleaner in 3 different ways.

Advantages of placing the **PowerUnit at the bottom** of the vacuum cleaner, see "Appliance description":

- Secure self-standing function possible (see "Operation" – "Self-standing function for short pauses in vacuuming")
- Ergonomic (reduced strain on the wrist)
- Convenient for cleaning large areas

Advantages of placing the **PowerUnit at the top** of the vacuum cleaner, see "Appliance description":

- Convenient for cleaning underneath low furniture
- Fast removal of the PowerUnit possible

Advantages of placing the **PowerUnit solo** on the vacuum cleaner:

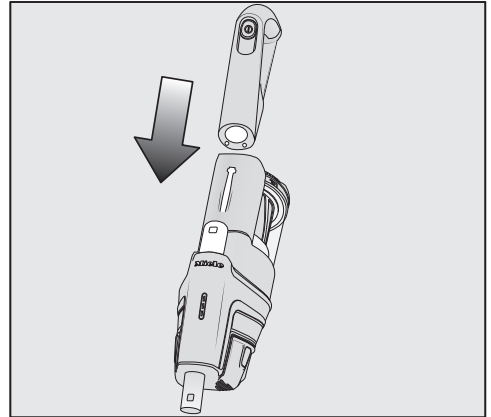

- Fast and targeted vacuuming of crumbs or fluff

This configuration is particularly suitable when using the three-piece accessory set.

Accessories included

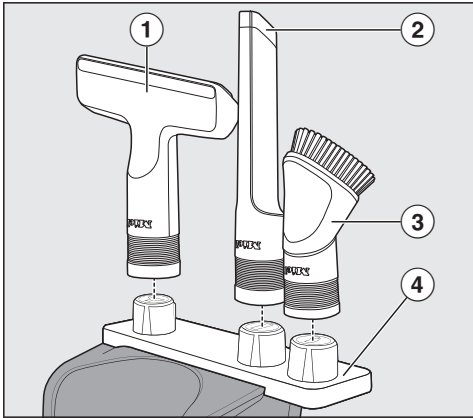

- ① **Upholstery nozzle XL**
Accessory for cleaning upholstery, mattresses and cushions.
- ② **Crevice nozzle**
Accessory for cleaning in folds, crevices or corners.
- ③ **Dusting brush**
Accessory for vacuuming skirting boards, carved furniture or ornaments.
The head can be swivelled to adjust the angle.
- ④ **Accessories holder for wall bracket**
For storing the three-piece accessory set.
You can fit the accessories holder to the wall bracket (see “Commissioning” – “Connecting the accessories holder”).

Accessories holder for the suction tube

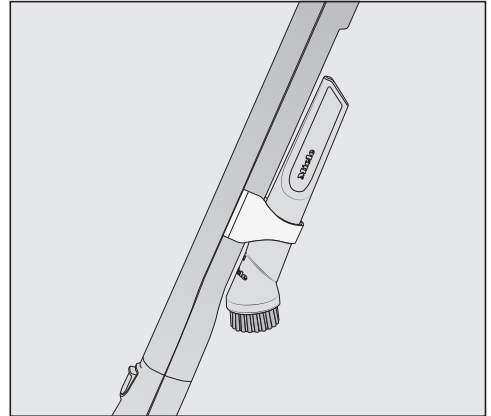

This accessories holder allows you to carry around 2 accessories from the three-piece accessory set while you vacuum.

Multi Floor XXL electrobrush

⚠ Damage caused by trapped material.

Risk of the flooring getting scratched.
Make sure that there is no coarse dirt or debris trapped in the bottom of the electrobrush, e.g. shards or stones.

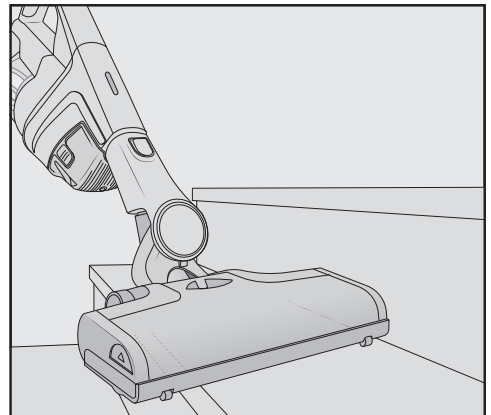

The electrobrush can be used for all normal cleaning of carpets, rugs and hard flooring which is not susceptible to scratching.

Hardfloor Care soft roller

(depending on the model)

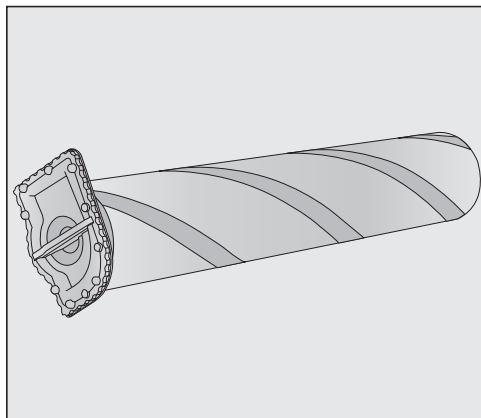

When fitted with the Hardfloor Care soft roller, the electrobrush can be used to clean delicate hard floors.

Insert the Hardfloor Care soft roller into the electrobrush instead of the roller brush fitted as standard (see “Cleaning and care” – “Removing the roller brush from the electrobrush”).

When you use the Hardfloor Care soft roller, the Electrobrush power rating is automatically set to the optimum level – this can lead to a change in the operating noise.

Electro Compact handheld brush

(depending on the model)

 Damage caused by trapped material.

Risk of the flooring getting scratched. Make sure that there is no coarse dirt or debris trapped in the bottom of the handheld brush, e.g. shards or stones.

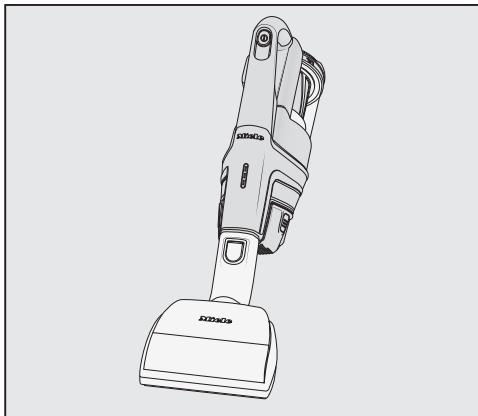

The handheld brush is particularly suitable for intensive cleaning of car seats and carpeted stairs.

For optimum cleaning results on upholstery, use the upholstery nozzle XL.

Additional battery (HX-LA)

(depending on the model)

Using the additional battery doubles the amount of time the vacuum cleaner can be used for.

Before charging the battery for the first time, you must read the information in “Commissioning” – “General battery information”.

3D4U

With 3D4U, Miele offers free accessories to download for your 3D printer (www.miele.com, Service, 3D4U).

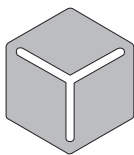

3 D 4 U

Battery charging state indicator (while charging)

The battery charging state is displayed on the PowerUnit.

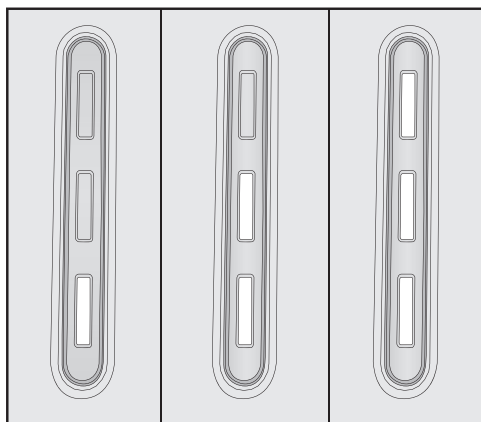

Charging capacity

Approx. 0–34 %

Indicator

Bottom light flashes slowly

Approx. 35–69 %

Bottom light is lit up; middle light flashes slowly

Approx. 70–90 %

Bottom and middle lights are lit up; top light flashes slowly

Approx. 91–99 %

Bottom, middle and top lights are lit up

100 %

Switches off (energy-saving mode)

Commissioning

Assembling the vacuum cleaner

Take care to assemble the vacuum cleaner exactly as specified in the appliance description until it clearly clicks into place (see “Familiarisation” – “Appliance description”).

If you position the handle or the suction tube on top of the PowerUnit, make sure to fit these parts **along the guide** onto the PowerUnit connector.

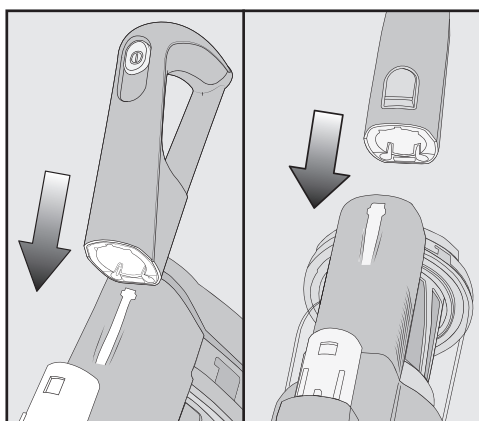

Separating components

- If you want to separate components from each other, press the corresponding release button (see “Familiarisation” – “Appliance description”).

General battery information

The rechargeable battery is supplied not fully charged.

Charge the battery completely before using it for the first time. Allow approximately 4 hours for this.

To activate the battery, it is essential to place it in the PowerUnit when charging it for the first time.

Once the battery is fully charged, the battery charging state indicator on the PowerUnit switches off to conserve energy.

The maximum charging capacity is only achieved once the battery has been charged and run down five times.

A full charge provides enough power for up to 14 minutes if the vacuum cleaner is used at the maximum power level in its fully assembled state.

However, if you use the PowerUnit solo and select the minimum power level, you can vacuum for up to 60 minutes at a time.

We recommend allowing the battery to run down completely before recharging it. In this way, you will benefit from the battery's full capacity.

If the battery has not been used for a long time and has run down, it will switch to safe mode. As a result, the battery charging state indicator will only respond after approximately 30–60 minutes when charging in the PowerUnit.

Inserting the battery

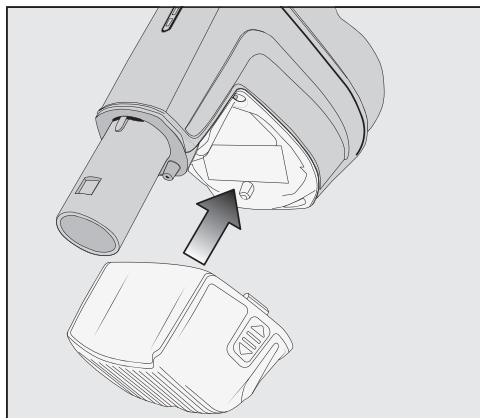

- Push the battery along the guide lines until it audibly clicks into place in the PowerUnit.

To activate the battery, it is essential to place it in the PowerUnit when charging it for the first time.

Charging the battery (without wall mounting)

You can store the vacuum cleaner upright and charge the battery directly.

Before charging the battery for the first time, you must read the information in “General battery information”.

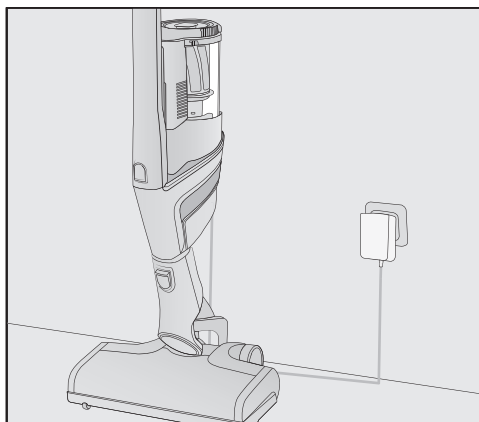

- Connect the PowerUnit to the electrobrush to provide a secure base for the vacuum cleaner.
- Swing the vacuum cleaner forwards until the electrobrush connector audibly clicks into place.
- Plug the charging plug of the supplied charging cable into the charging socket on the bottom of the battery.
- Plug the charger into a power socket.

The charging process will start.

Charging the battery (with wall mounting)

There are 2 ways to store and charge the vacuum cleaner in the supplied wall bracket.

You will need a suitable location near a free power socket for mounting the appliance on the wall. Before charging the battery for the first time, you must read the information in "General battery information".

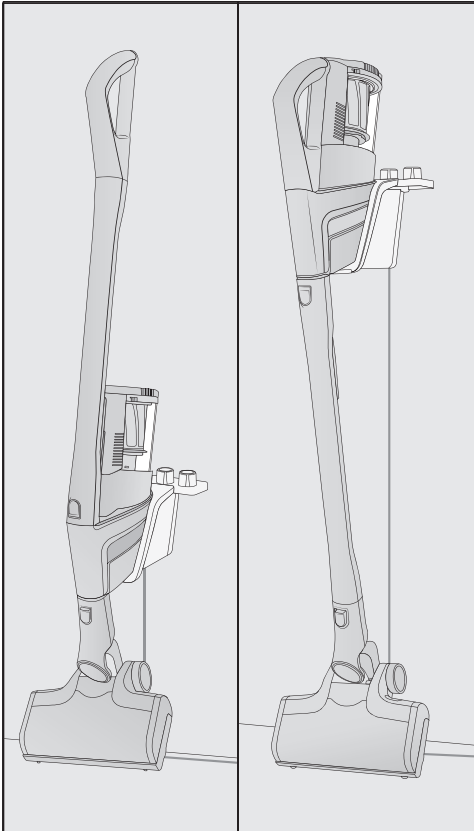

Wall mounting

The supplied wall bracket has a mounting plate with a bag of screws attached to the back.

Attach the mounting plate to the point on the wall where you want the wall mounting to be.

- Remove the bag of screws.

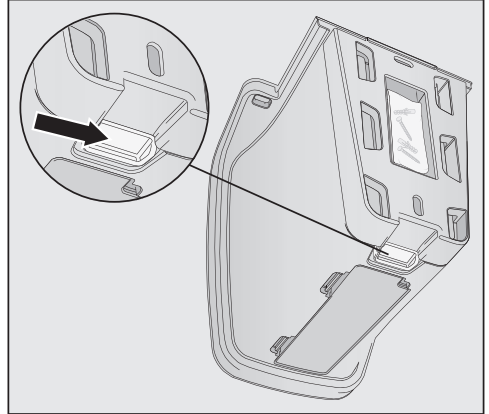

- Press the release catch at the bottom of the wall bracket.

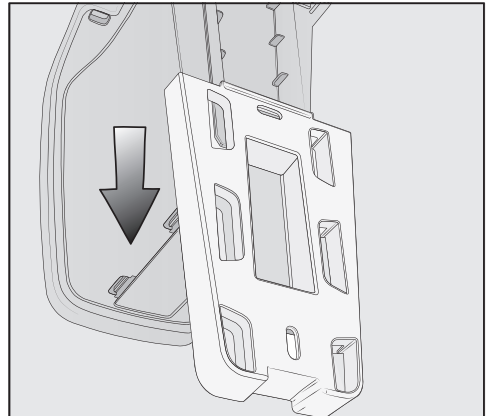

- Remove the mounting plate from the wall bracket by sliding it downwards.

Attaching the mounting plate

2 plugs and 2 T20 TORX screws are supplied in the screw bag for attaching the mounting plate to the wall.

You will also need a battery-operated screwdriver or a drill (with a drilling diameter of 6 mm).

Depending on how you decide to configure your vacuum cleaner, select a distance of 45 cm or 98 cm between the bottom edge of the mounting plate and the floor.

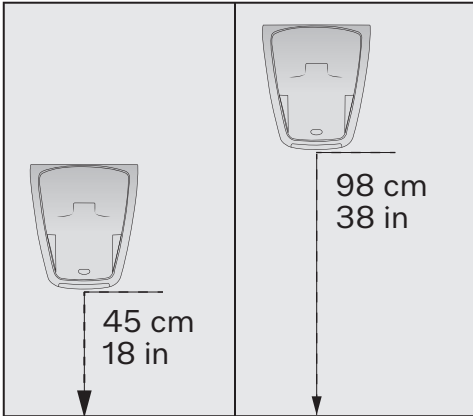

Be careful not to damage any cables laid in the wall.

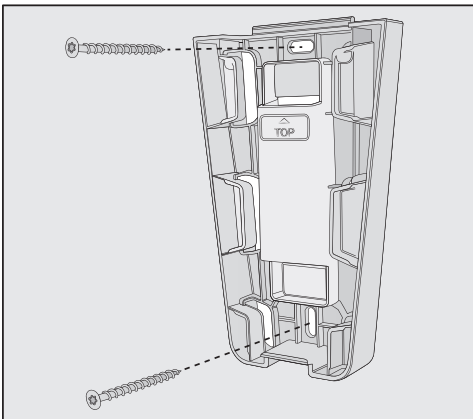

■ Attach the mounting plate to the wall.

Attaching the charging cable to the wall bracket

A cable compartment is located on the underside of the wall bracket.

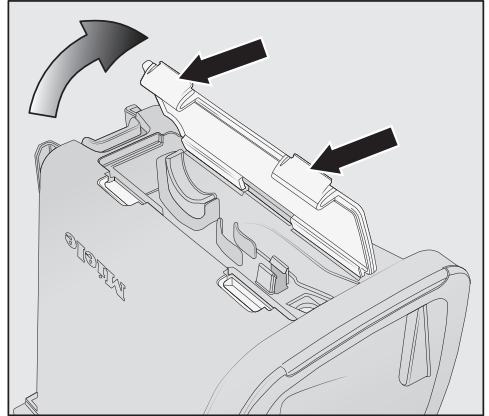

■ Press both release catches on the underside of the wall bracket and remove the cable compartment cover.

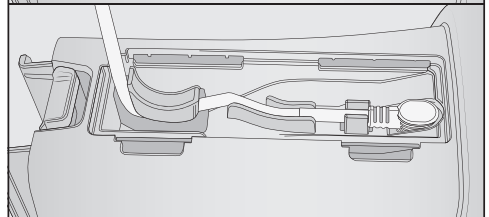
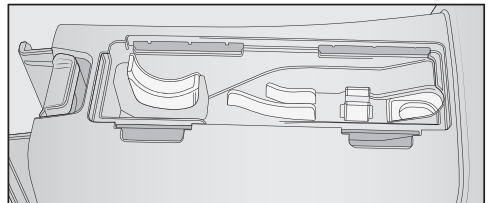

■ Plug the supplied charging cable into the opening from above.
■ Lay the charging cable in its guide.

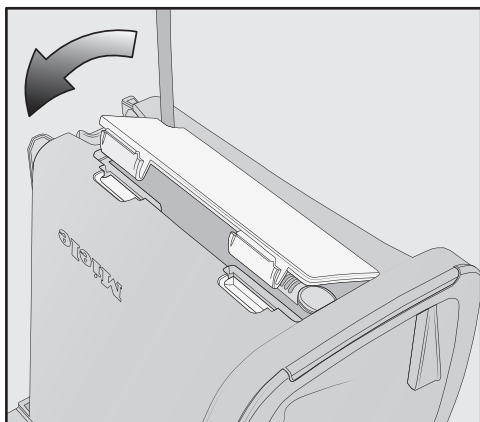

- Refit the cover and lock the cable compartment.
- Then turn over the wall bracket.

Connecting the accessories holder (if required)

An accessories holder is supplied for storing the three-piece accessory set on the wall bracket (see “Familiarisation” – “Accessories included”).

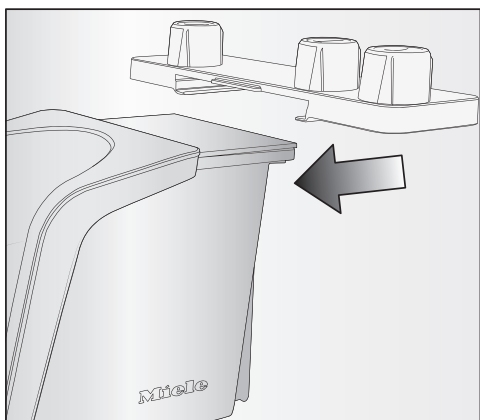

- Push the accessories holder onto the wall bracket as far as it will go.

Connecting the wall bracket

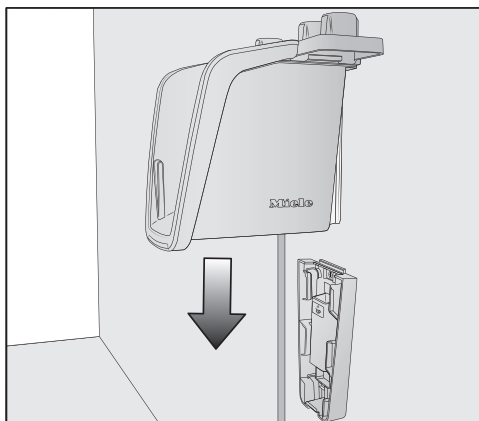

- Slide the wall bracket down into the mounting plate from above until it audibly clicks into place.

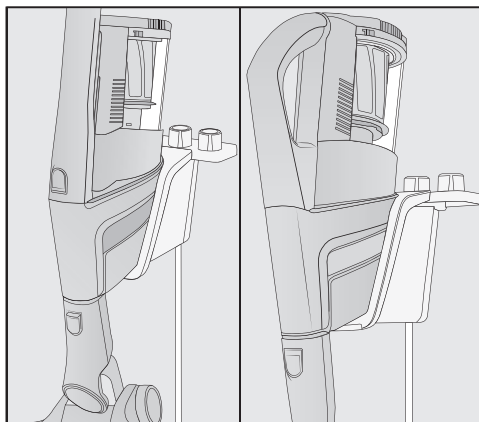

- Insert the fully assembled vacuum cleaner, with the battery inserted, down into the wall bracket from above.
- Plug the charger into the power socket.

The charging process will start.

Removing the battery

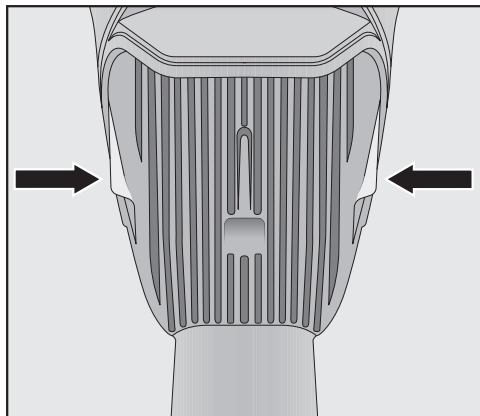

- Press both release buttons at the side of the battery at the same time to remove the battery.

Charging the battery in the battery charger cradle

(depending on the model)

Before charging the battery for the first time, you must read the information in “General battery information”.

When charging the battery for the first time, you must use the PowerUnit. As of the second charging operation, you can use the battery charger cradle instead.

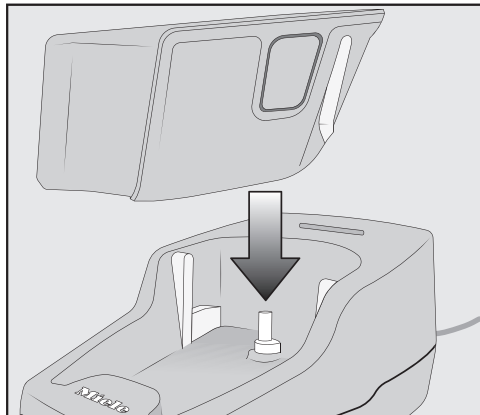

- Push the battery into the charger cradle until it audibly clicks into place.
- Insert the mains plug into a power socket.

The charging process will start. The battery charging state indicator flashes on the left.

If you place the run-down battery in the charger cradle straight after use, it will only start charging once the battery has cooled down. The cooling process can take up to 60 minutes. The battery charging state indicator on the charger cradle will not respond during this time.

Operation

Switching on and off

- If you have charged the battery in the wall bracket, take the vacuum cleaner out of the wall bracket.
- If you have charged the battery directly, unplug the charging plug from the charging socket on the bottom of the battery.

For the best possible cleaning results, always use the ComfortClean function before switching on the vacuum cleaner (see “Cleaning and care” – “Using the ComfortClean function”).

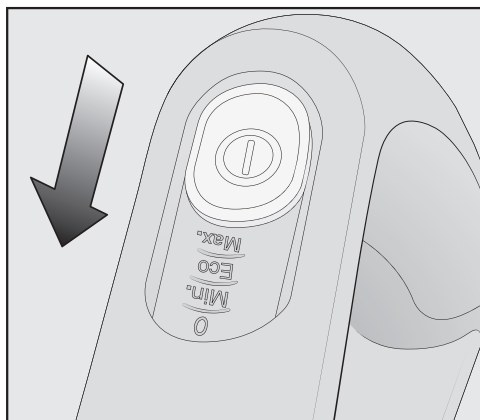

- Press the On/Off switch on the handle ①.

Selecting the suction power level

Reducing the suction power reduces the amount of effort required to manoeuvre the electrobrush.

There are 3 power levels to choose from on the handle:

Min.	Lowest power level for light soiling
Eco	Medium power level for normal soiling
Max.	Highest power level for heavy soiling

The flooring detection is activated at every power level.

The electrobrush power rating is automatically set to the optimum level based on the type of flooring and roller brush used – this can lead to a change in the operating noise.

Battery charging state indicator (while in use)

The battery charging state is displayed on the PowerUnit.

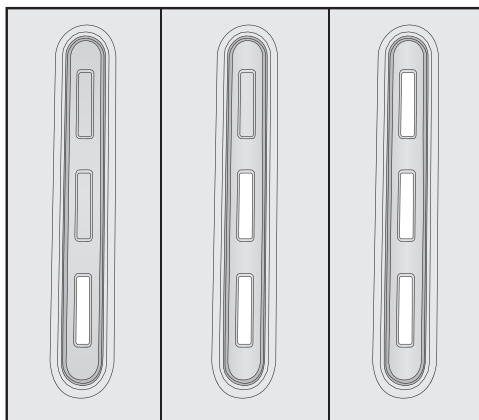

Charging capacity

Indicator

Approx. 100–70 %

Top, middle and bottom lights are lit up

Approx. 69–35 %

Middle and bottom lights are lit up

Approx. 34–15 %

Bottom light is lit up

Approx. 14–0 %

Bottom light flashes slowly

Self-standing function for short pauses in vacuuming

⚠ Risk of injury caused by vacuum cleaner falling over.

Only use the self-standing function when the PowerUnit is fitted at the bottom of the vacuum cleaner.

Do not use the self-standing function if the vacuum cleaner is on a sloping surface, e.g. a ramp.

- Swing the vacuum cleaner forwards until the electrobrush connector audibly clicks into place.

The vacuum cleaner stays securely upright, the electrobrush switches itself off and the battery is conserved. If you then unlock the connector on the electrobrush, the electrobrush will switch on again.

Good to know

Cleaning tips

Tip: The suction tube is not a convenient option for cleaning car seats or stairs.

Tip: If you ever need to vacuum up substantial amounts of coarse dirt or debris, use the PowerUnit solo configuration concept (see “Familiarisation” – “Vacuum cleaner configuration options”).

Cleaning and care

Caring for the vacuum cleaner and accessories

⚠ Risk of injury caused by rotating roller brush.

You can injure yourself on the rotating roller brush.

Always switch the vacuum cleaner off before caring for it. Use the On/Off switch on the handle to do this.

⚠ Risk of electric shock from mains voltage.

If moisture gets into the charger, there is a risk of electric shock. Do not let the charger get wet.

- Follow the special cleaning instructions for the dust container, see “Cleaning the dust container”.

- The vacuum cleaner and all plastic accessories should be cleaned with a commercially available cleaner suitable for plastic.

⚠ Damage due to unsuitable cleaning agents.

All surfaces are susceptible to scratching. Contact with unsuitable cleaning agents can alter or discolour the external surfaces.

Do not use abrasive cleaning agents, glass cleaning agents, all-purpose cleaners or oil-based care products.

Filter system

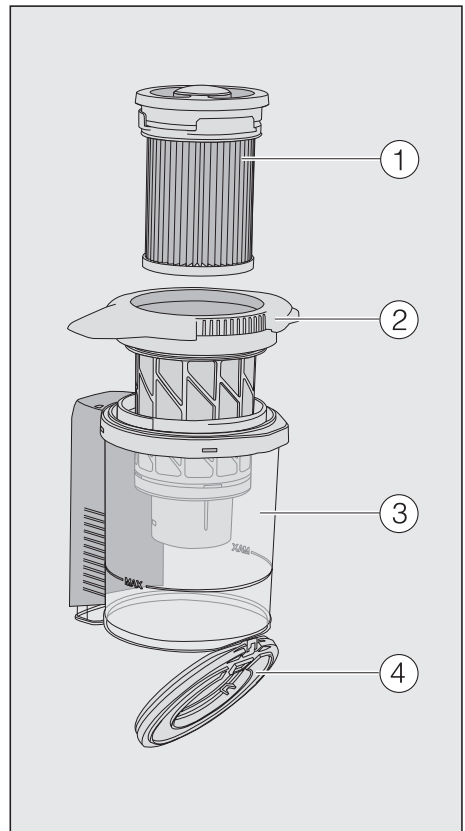

- ① Fine dust filter (HX-FSF-2)
- ② Pre-filter
- ③ Dust container
- ④ Dust container flap

Using the ComfortClean self-cleaning function

Always run the interim cleaning function for the fine dust filter before emptying the dust container. You should also run it whenever the suction power begins to drop.

This enables the vacuum cleaner to achieve the very best cleaning results again straight away.

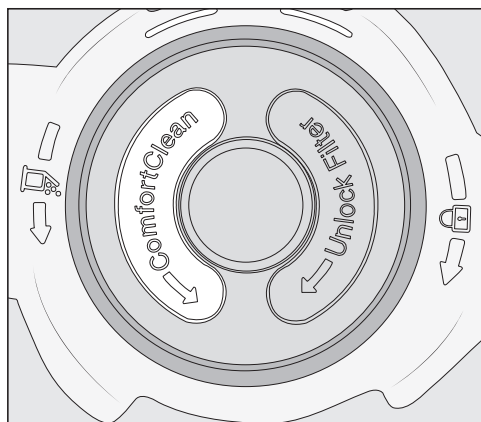

- The fine dust filter is located in the lid of the dust container. Twist it anti-clockwise by 3 180° turns. Use the recesses to help you do this.

When turning the cap, you will hear a noise, which is a normal part of how the ComfortClean self-cleaning function works.

Emptying the dust container

Empty the dust container at the latest when the dust has reached the **MAX** marking on the dust container.

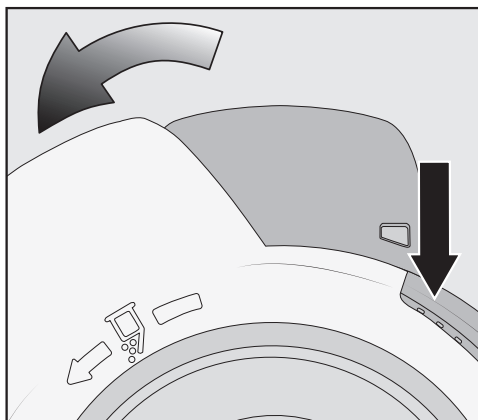

- Turn the lid of the dust container in the direction of the arrow as far as the first stop. Use the grey gripping surfaces to help you do this.

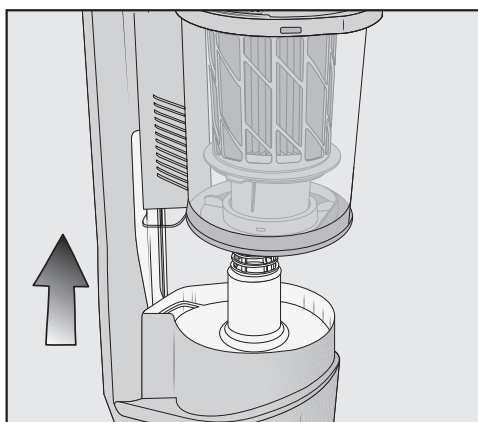

- Lift the dust container upwards to remove it.

Provided that no prohibited substances are present, the contents of the dust container can be disposed of with normal household waste.

- Hold the dust container close to the bin to prevent dust from billowing out.

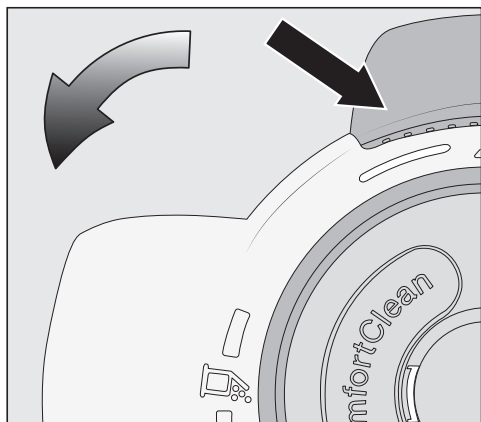

- Turn the lid of the dust container in the direction of the arrow as far as the next stop. Use the grey gripping surfaces to help you do this.

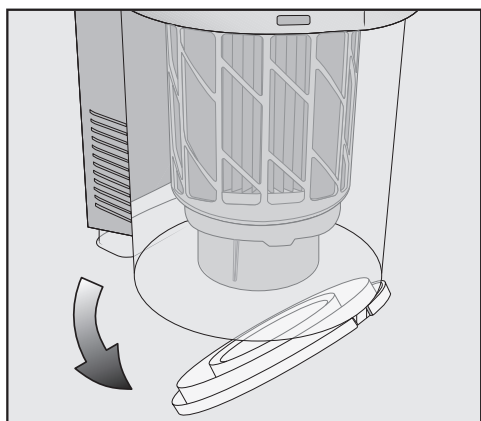

The dust container flap will open and the dust will fall out.

If chunks of dust, hair or coarse debris do not fall out, remove the pre-filter by pulling it upwards (see “Cleaning the pre-filter and fine dust filter” below).

- Turn the lid of the dust container back to its original position.
- Close the dust container flap, making sure it clicks into place.

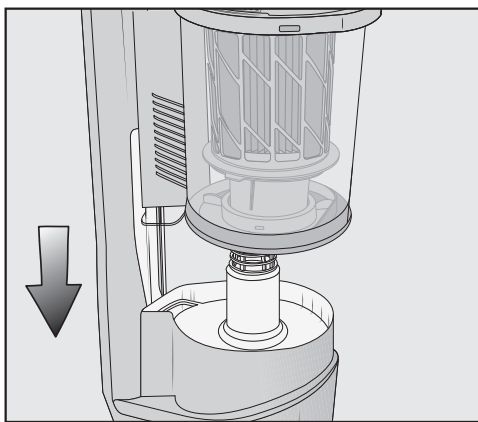

- Slide the dust container handle along the guide line and down onto the PowerUnit connector from above until the dust container audibly clicks into place.

Cleaning the pre-filter and fine dust filter

Clean both filters thoroughly at least once every 3 months.

When cleaning them, it is essential to follow the steps in the order described.

- Remove the dust container.
- Empty the dust container over a bin.

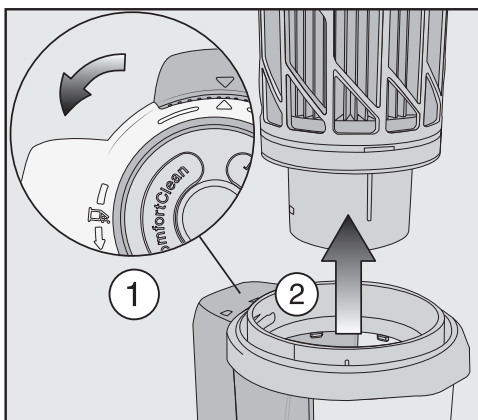

- Turn the lid of the dust container beyond the stop until the arrow tips are aligned at the top ①.
- Remove the pre-filter by pulling it upwards ②.

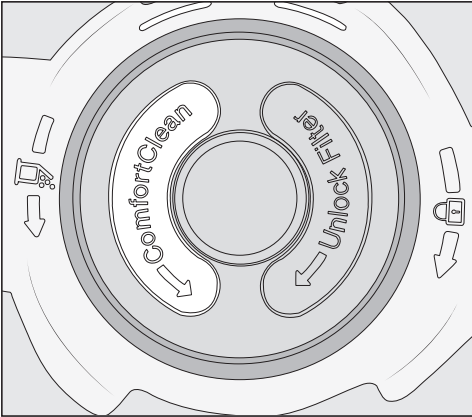

- Twist the fine dust filter anti-clockwise by 10 180° turns. Use the recesses to help you.

You will hear an operating noise, which is a normal part of how the Comfort-Clean function works.

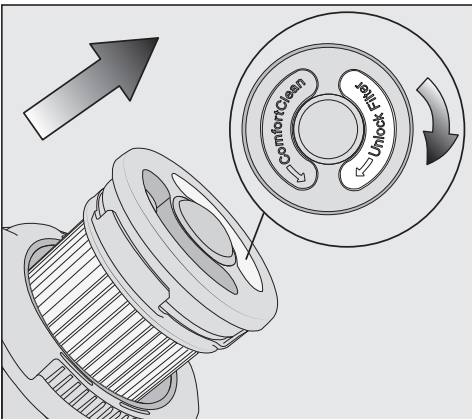

- Twist the fine dust filter clockwise. Use the recesses to help you.
- Remove the fine dust filter.

⚠ Risk of damage caused by incorrect cleaning.

The fine dust filter can become damaged and be less effective as a result. Do not clean the fine dust filter with water and avoid cleaning the inside. Do not use pointed or sharp-edged objects to clean the filter. Do not brush the fine dust filter.

- Hold the fine dust filter over a bin.
- Empty the fine dust filter by carefully tapping the rubberised lower edge.
- Turn the fine dust filter slightly while you do this to free the dirt from all of the crevices.

⚠ Risk of damage caused by incorrect cleaning.

The pre-filter can become damaged and be less effective as a result. Do not clean the pre-filter with water. Do not use pointed or sharp-edged objects to clean the filter.

- Clean the pre-filter with the dusting brush supplied or with a dry cloth.
- After cleaning the fine dust filter and pre-filter, reinsert the former into the latter by pressing the round cap on top of the fine dust filter down as far as it will go.

To continue achieving the best possible cleaning results, replace the fine dust filter (HX FSF-2) with a new one after approx. 3 years.

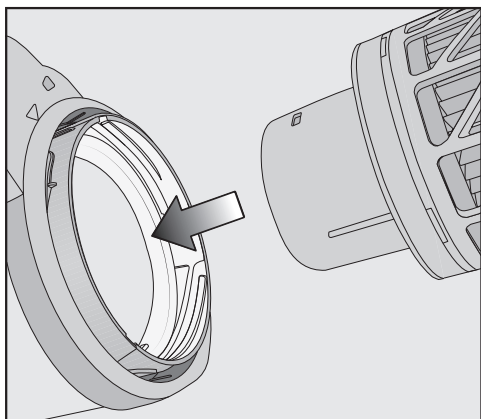

- Reinsert the pre-filter in the dust container.

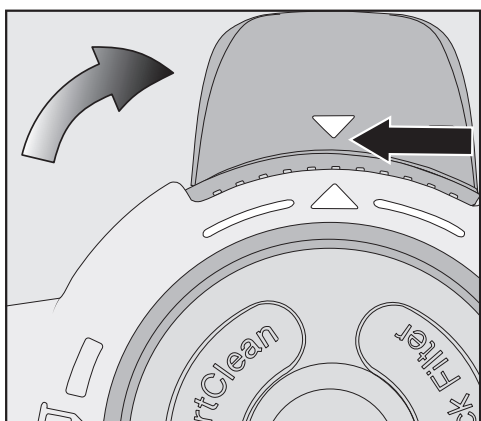

- To do this, line up the guides (arrows) and turn the pre-filter back to its original position.
- Close the dust container flap, making sure it clicks into place.
- Reattach the dust container to the PowerUnit connector.

Cleaning the dust container

Clean the dust container as required.

- Clean the dust container using water and mild washing-up liquid.
- Dry the dust container thoroughly.

Cleaning the Electrobrush/handheld brush (depending on model)

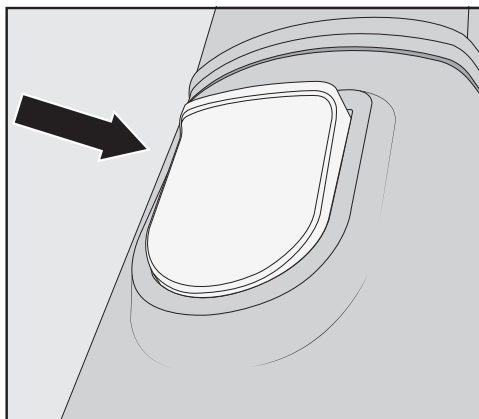

- Disconnect the Electrobrush/handheld brush from the vacuum cleaner.
- Place the Electrobrush/handheld brush upside down on a level, clean surface.

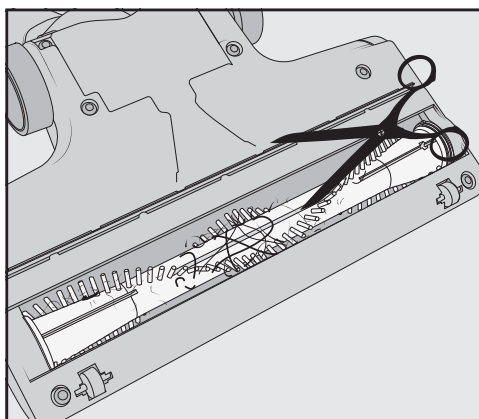

- Cut any threads or hairs that have wound themselves around the roller brush with a pair of scissors. To guide the scissors, move along the guide track on the roller brush.

Then run the vacuum cleaner to vacuum up the cut threads and hairs.

If the small running wheels are very heavily soiled or blocked, you can remove them for easier cleaning (not necessary in the case of the handheld brush). To remove them, use a flat-head screwdriver.

Removing the roller brush from the Electrobrush

(Not possible with the handheld brush)

You can take the roller brush out of the Electrobrush in order to remove stubborn soiling and clean the inside of the Electrobrush.

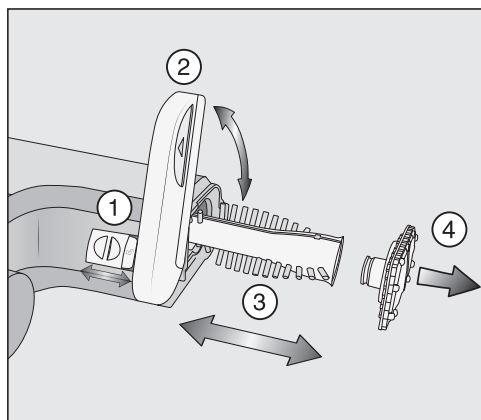

- Unlock the cover on the side of the Electrobrush so that the  symbol becomes visible ①.
- Lift the cover up as far as it will go ②.
- Remove the roller brush ③.
- Remove the roller brush handle if you identify heavy soiling there ④.
- Clean the roller brush and the roller brush handle, and remove any stubborn soiling inside the Electrobrush.
- Reassemble the Electrobrush in reverse order.

Replacing the rechargeable battery

An original Miele AP01/AP02/AP03 lithium-ion rechargeable battery (HX-LA) is required.

Follow the instructions regarding the handling and disposal of rechargeable batteries found in the following sections: “Warning and safety notes”, “Sustainability and environmental protection” and “Commissioning” (“General battery information”).

Troubleshooting

Many malfunctions and faults can be easily remedied. You can save time and money in many cases, as you do not need to contact Customer Service.

More information to help you remedy faults yourself can be found at www.miele.de/support/customer-assistance. Alternatively, scan the QR code.



 Risk of injury caused by rotating roller brush.

You can injure yourself on the rotating roller brush.

Switch the vacuum cleaner off before dealing with any problems. Use the On/Off switch on the handle to do this.

Error messages are displayed with a quick flashing light on the battery charging state indicator on the PowerUnit.

Problem	Cause and remedy
Top indicator is flashing quickly	“Handle not recognised” fault <ul style="list-style-type: none">■ Remove the handle and refit it until it clicks into place.■ Remove the battery, wait for 10 seconds and reinsert it.
Middle indicator is flashing quickly	“Motor overheating” fault <ul style="list-style-type: none">■ Empty and clean the dust container, pre-filter and fine dust filter.■ Remove the battery, wait for 10 seconds and reinsert it.■ Wait for approximately 30 minutes before switching the vacuum cleaner back on again.
Middle and top indicators are flashing quickly	“Jammed roller brush” fault <ul style="list-style-type: none">■ Select a lower power level.■ Clean the electrobrush.■ For stubborn soiling, remove the roller brush from the electrobrush. Clean the roller brush and the inside of the electrobrush.

Problem	Cause and remedy
The bottom and middle indicators are flashing quickly	"Battery overheating" or "Battery not recognized" error <ul style="list-style-type: none"> ■ Wait for approximately 30 minutes before switching the vacuum cleaner back on again. ■ Insert an original Miele AP01/AP02/AP03 lithium-ion rechargeable battery (HX LA).
Bottom and top indicators are flashing quickly	Internal system error <ul style="list-style-type: none"> ■ Remove the battery, wait for 10 seconds, reinsert it and charge it.

After sales service

Contact in case of malfunction

In the event of any faults which you cannot remedy yourself, please contact Miele.

Contact information for Miele can be found at the end of this document.

Warranty

The manufacturer's warranty for this appliance is 2 years.

For more information about country specific warranty terms and conditions, please contact Miele.

Electrical connection

All work should be carried out by a suitably qualified and competent person in strict accordance with national and local safety regulations. The voltage and rated load are given on the data plate located underneath the vacuum cleaner. Please ensure that these match the household mains supply. The charger is supplied with a cable and moulded plug ready for connection to a 230V/50Hz AC single phase supply.

Test Marks	Electrical safety RCM Mark
Electrically suppressed according to	CISPR 14.1

Optional accessories

Please observe the flooring manufacturer's cleaning and care instructions.

Please note that faults and damage caused by use of accessories which do not bear the Miele logo on the packaging are not covered by the vacuum cleaner warranty.

These and many other products can be ordered from the Miele online shop, the Miele Customer Service Department or your Miele dealer.

Certain models are supplied with one or more of the following accessories as standard.

Electro Compact handheld brush (HX-EC 10)

For intensive cleaning of car seats and carpeted stairs.

Hardfloor Care soft roller (HX HC)

For cleaning delicate hard floors.

Universal brush (HX-UB)

For gentle vacuuming of books, shelves or similar.

Radiator brush (SHB 30)

For dusting radiators, narrow shelves and crevices.

Mattress nozzle (SMD 10)

For vacuuming upholstery, mattresses, cushions, curtains, covers etc.

Crevice nozzle, 300 mm (SFD 10)

Extra long crevice nozzle for cleaning in folds, crevices and corners.

Crevice nozzle, 560 mm (SFD 20)

Flexible crevice nozzle for vacuuming hard to reach places.

Extendable flexible XL crevice nozzle (HX-CNXL)

The flexible crevice nozzle can reach 60 cm for cleaning hard-to-reach areas.

Hose extension (HX-FSH 10)

For increasing the vacuuming radius by maximum 120 cm.

AP01/AP02/AP03 additional battery (HX-LA)

For doubling the amount of time the vacuum cleaner can be used for.

LS03/LS04 charger cradle (HX-LS)

For charging the additional battery independently of the appliance, i.e. while the appliance is in use.



Miele

Miele Australia Pty. Ltd.

ACN 005 635 398

ABN 96 005 635 398

Level 4, 141 Camberwell Road
Hawthorn East, VIC 3123

1300 464 353 (1300 4 MIELE)

info@miele.com.au

www.miele.com.au

Miele New Zealand Limited

IRD 98 463 631

8 College Hill
Freemans Bay, Auckland 1011

0800 464 353 (0800 4 MIELE)

customercare@miele.co.nz

www.miele.co.nz

Miele Global Headquarters

Germany

Miele & Cie. KG

Carl-Miele-Straße 29

33332 Gütersloh

Federal Republic of Germany