



Installation plan Commercial washing machine PWM 511 GB





Always read the operating instructions before setting up, installing and commissioning the machine. This prevents both personal injury and damage to the machine.

en-GB

Contents

Installation notes	3
Explanation of the safety notes and warnings on the machine	3
Installation requirements	3
General operating conditions	3
Transportation and site access.....	3
Installation.....	3
Installation on concrete plinth.....	4
Levelling the machine	4
Electrical connection	5
Plumbing.....	6
Cold water connection.....	6
Hot water connection	6
Drain valve (depending on model)	6
Drain pump (depending on model)	7
Dispenser connection.....	8
Optional accessories	9
Connector Box	9
WiFi/LAN interface.....	10
Plinth (APWM037/038/039)	10
Installation	11
Standard	11
Plinth	13
Plinth	14
Installation	15
Standard	15
Plinth	16
Securing the machine	17
Technical data	18
Voltage versions and electrical data	18
Plumbing.....	19
Cold water connection.....	19
Hot water connection	19
Drain valve (DV)	19
Drainage (DP).....	19
Equipotential bonding.....	19
Installation dimensions	19
Anchoring.....	20
Transport data, weight and floor load.....	20
Emissions data.....	20

Explanation of the safety notes and warnings on the machine

	Read the operating instructions
	Warning, hot surfaces
	Warning, voltage up to 1000 volts
	Protective earthing
	Equipotential bonding

Installation requirements

The washing machine must be installed and commissioned by a Miele Customer Service technician or by an authorised dealer.

- ▶ Suitable personal protective equipment must be worn during installation or maintenance.
- ▶ The washing machine must be installed in accordance with applicable regulations and standards. Local energy supplier and water authority regulations must also be observed.
- ▶ This washing machine must only be operated in a room that has sufficient ventilation and which is frost-free.

This washing machine should not be installed or operated in any area where there is a risk of explosion!

General operating conditions

This washing machine is intended only for use in a commercial environment and must only be operated indoors.

- Ambient temperature: 0-40 °C
- Relative humidity: non-condensing
- Maximum height above sea level of location site: 2000 m

Depending on the nature of the installation site, sound emissions and vibration may occur.

Tip: Have the installation site inspected and seek the advice of a professional in instances where increased noise may cause a nuisance.

Transportation and site access

The machine must not be moved without the transit bars in place. Keep the transit bars in a safe place. They must be refitted if the machine is to be moved again (e.g. when relocating the machine).

Installation

Transport the washing machine to its installation site using a suitable pallet truck and remove the transport packaging.

Installation notes

The washing machine must be set up on a completely level, horizontal and firm surface with the minimum stated load bearing capacity (see “Technical data”).

Tip: A concrete floor is the most suitable installation surface. It is far less prone to vibration during the spin cycle than wooden floorboards or a carpeted surface.

The floor load created by the washing machine is the load exerted by the area of the machine in contact with and transferred to the installation surface.

The washing machine requires a gap of at least 50 mm on each side to allow for movement during operation. Please ensure a minimum distance of 400 mm is maintained between the rear of the appliance and the rear wall.

The washing machine must not be installed on a carpeted floor.

The feet of the washing machine must be secured to the fastening points on the floor using the fittings supplied.

The fittings supplied are for bolting the machine to a concrete floor. If other floor types are present at the installation site, the fastening material must be ordered by the customer.

Installation on concrete plinth

The washing machine can be installed on a concrete plinth if desired.

The concrete materials and the durability of the concrete plinth must be assessed in accordance with the floor load bearing capacity given in “Technical data”.

- To guarantee the stability of the washing machine, make sure that the concrete plinth is sufficiently stable on the floor and that it is capable of withstanding any burden or force from the washing machine.
- The washing machine must be secured to the concrete plinth using the fixtures and fastenings supplied.

 The washing machine must be secured to the plinth immediately after installation!

There is a risk of the washing machine falling off a raised plinth during a spin cycle if it is not secured.

Levelling the machine

- Align the washing machine vertically and horizontally using the adjustable feet and a spirit level.

The washing machine must stand evenly and horizontally on all four feet to ensure trouble-free and energy-efficient operation. Otherwise the water and energy consumption increases and the washing machine might move around.

- After aligning the machine, tighten the lock nuts by turning them in a counterclockwise direction with a spanner. This will prevent the feet from adjusting themselves.

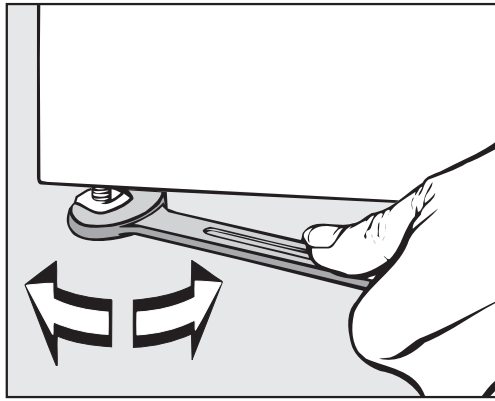

Electrical connection

The electrical connection must only be carried out by a qualified electrician who must ensure that all electrical work is carried out in accordance with applicable electrical regulations and standards (BS 7671 in the UK).

- ▶ This washing machine must be connected to an electrical mains supply that complies with local and national regulations. Please also observe your insurance and energy supplier's regulations as well as any health and safety at work regulations.
- ▶ The required voltage, connected load and fusing rating can be found on the data plate on the washing machine. Before connecting the machine to the power supply, please ensure that the mains supply voltage complies with the values given on the data plate.

Connection to a supply voltage other than the one quoted on the data plate can lead to functional faults and damage the washing machine!

If more than one voltage is quoted on the data plate, the washing machine can be converted for connection to the voltages stated.

- ▶ Conversion to a different voltage must only be carried out by a Miele Service engineer or by an authorised Service Partner. The wiring instructions given on the wiring diagram must be followed.

Tip: We recommend connection to the power supply via a suitably rated plug and socket which must be easily accessible for servicing and maintenance work after the machine has been installed. An electrical safety test must be carried out after installation and after any service work.

The machine should be connected with a suitably rated plug and socket in accordance with IEC 60309-1 or hard wired. For a hard wired connection an all-pole isolation device must be installed.

For hard-wired machines connection should be made via a suitable mains switch with all-pole isolation which, when in the off position, ensures a 3 mm gap between all open contacts. These include circuit breakers, fuses and relays (IEC/EN 60947).

If the mains supply cannot be permanently disconnected, the isolator switch (including plug and socket) must be safeguarded against being switched on either unintentionally or without authorisation.

Installation notes

► If it is necessary to install a residual current device (RCD) in accordance with local regulations, a residual current device type B (sensitive to universal current) must be used.

An existing type A residual current device (RCD) must be exchanged for a type B RCD.

► If local and national installation specifications require equipotential bonding, good galvanic contact must be guaranteed. Equipotential bonding must have an earth current rating > 10 mA.

Plumbing

Cold water connection

For the cold water connection one stopcock each with a $\frac{3}{4}$ " screw thread is required.

If a water connection is not available, only a qualified installer may connect the washing machine to the mains water supply.

The water inlet hose for cold water is not suitable for connection to a hot water supply.

In the event that hot water is not available on site, a cold water supply must be used for the hot water connection.

The required amount of hot water should be added to the cold water volume.

Alternatively, the hot water connection should be blocked using the blind stopper supplied with the machine and the machine controls should be set to cold water intake by the service technician.

Hot water connection

The same connection requirements as for cold water also apply to hot water up to 60 °C.

A suitable connection hose with a threaded union is supplied with the machine.

The machine with hot water connection also requires a cold water connection.

In the event that hot water is not available on site the hot water connection should be blocked using the blind stopper and the machine controls should be set to cold water intake.

Alternatively a cold water supply can be used for the hot water connection.

The required amount of hot water should be added to the cold water volume.

Drain valve (depending on model)

In the case of washing machines with a drain valve, a motorised valve is used to drain the machine. An HT DN 70 angle connector can be used for draining the machine directly into the waste water system (without a siphon) or into an on-site floor drain (with odour trap).

Thanks to an improved closing mechanism and a larger cross-section, even the coarsest of soiling does not leave any deposits or debris behind which could result in blockages. The drain valve can also be operated manually to allow the suds container to be emptied in the event of a power outage.

A vented drainage system is vital for unimpeded drainage. If several machines are connected to a single drain pipe, this should be sufficiently large to allow all machines to drain simultaneously. The appropriate Miele installation kit (mat. no.: 05 238 090) is available to order from the Miele Customer Service Department or your Miele dealer for venting an HT DN 70 pipe. If the slope for drainage is extremely steep, the piping must be vented to prevent formation of a vacuum in the washing machine's drainage system.

Slow or obstructed drainage or a backup of water in the washing machine drum as a result of undersized pipework can result in faults occurring during programmes, which will result in fault messages appearing in the display.

 Outflowing suds can be as hot as 95 °C. Danger of burning! Avoid direct contact.

Drain pump (depending on model)

In machines with drain pump, the suds are drained through a drain pump with a delivery head of max. 1 m.

The drain hose must be installed free of kinks for the suds to drain freely.

There are the following options for draining the machine:

- Drain hose connected to a plastic drain pipe with a rubber sleeve (there is no need to use a siphon)
- Drain hose connected securely to a sink with a plastic nipple

If required, the hose can be extended to a length of up to 5 m. The corresponding accessories are available from the Miele Customer Service Department or your Miele dealer.

For a drain height of more than 1 m, a replacement drain pump for a delivery head of max. 1.8 m is available from the Miele Customer Service Department or from your Miele dealer.

Water connection

For compliance to The Water Supply (Water Fittings) Regulations 1999, please fit the double check valves included in the scope of supply to the on-site water supply for every water inlet hose used. The double check valves prevent water from the inlet hoses flowing back into the on-site drinking supply. Non-return valves are included in the scope of supply.

The flow pressure must be a minimum of 100 kPa and must not exceed 1000 kPa. If the flow pressure is higher than 1000 kPa, a pressure reducing valve must be used. The machine must be connected to the water supply using the inlet hoses included in the scope of supply.



The connection points are subject to water supply pressure. Turn on the stopcock slowly and check for leaks. Correct the position of the seal and screw thread if appropriate.

Dispenser connection

The machine is equipped with an interface for external dispenser systems. Adapters for pre-mixed suds or liquid detergent from external dispenser systems for up to 6 connections should be obtained from the Miele Customer Service Department and connected.

A separate Connector Box is required for controlling the dispensing pumps electrically. This must be installed by your Miele dealer or the Miele Customer Service Department. It is particularly important to follow the manufacturer's instructions when using a combination of cleaning agents and special application products.

Optional accessories

Only use genuine Miele spare parts and accessories with this machine.

Using spare parts or accessories from other manufacturers will invalidate the warranty, and Miele cannot accept liability.

Connector Box

The Connector Box allows external hardware from Miele and other suppliers to be connected to the Miele Professional washing machine. The Connector Box is supplied with mains voltage by the Miele Professional washing machine.

The separately available set consists of the Connector Box and fasteners for installation on the machine or on the wall.

Peak load / energy management

A peak-load or energy management system can be connected via the Connector Box.

The energy management system monitors the energy consumption of a system and deactivates individual pieces of equipment temporarily by means of the peak-load negotiation in order to ensure that certain total load limits are not exceeded.

When the peak-load function is activated, the heating is deactivated and the programme stopped. A message appears in the display to inform you of this.

The programme is resumed automatically when the peak-load function finishes.

Liquid dispensing connection

External liquid dispensing pumps can be controlled by the Connector Box to dispense liquid detergents. An input for empty sensing is assigned to each dispensing pump output. These inputs can be used if required. In addition, flow meters can be connected to each dispensing outlet to monitor the dispensing quantity.

It is particularly important to follow the manufacturer's instructions when using a combination of cleaning agents and special application products.

Payment device

The washing machine can be fitted with a single-machine payment system as an optional accessory via the Connector Box.

The programming required for connecting a payment system can be carried out during the initial commissioning process. After initial commissioning, changes may only be carried out by your Miele dealer or the Miele Customer Service Department.

Please note that the status of the Connector Box must be set to "on" in the supervisor level as required. The payment system settings can be configured at the supervisor level.

The payment system is not activated via the supervisor level.

Installation notes

WiFi/LAN interface

The washing machine is equipped with a WiFi/LAN interface for exchanging data.

The data interface provided on the LAN connection complies with SELV (Safety Extra Low Voltage). The LAN connection uses a RJ45 connector in accordance with EIA/TIA 568-B.

Connected machines must also comply with SELV.

Plinth (APWM037/038/039)

The washing machine can be installed on a plinth (open or box plinth, available as an optional Miele accessory).

Elevating the washing machine gives a better ergonomic working position when loading or unloading. It also simplifies the installation of a drain connection.

 The washing machine must be secured to the plinth immediately after installation. The plinth must be secured to the floor. There is a risk of the washing machine falling off a raised plinth during a spin cycle if it is not secured.

Standard

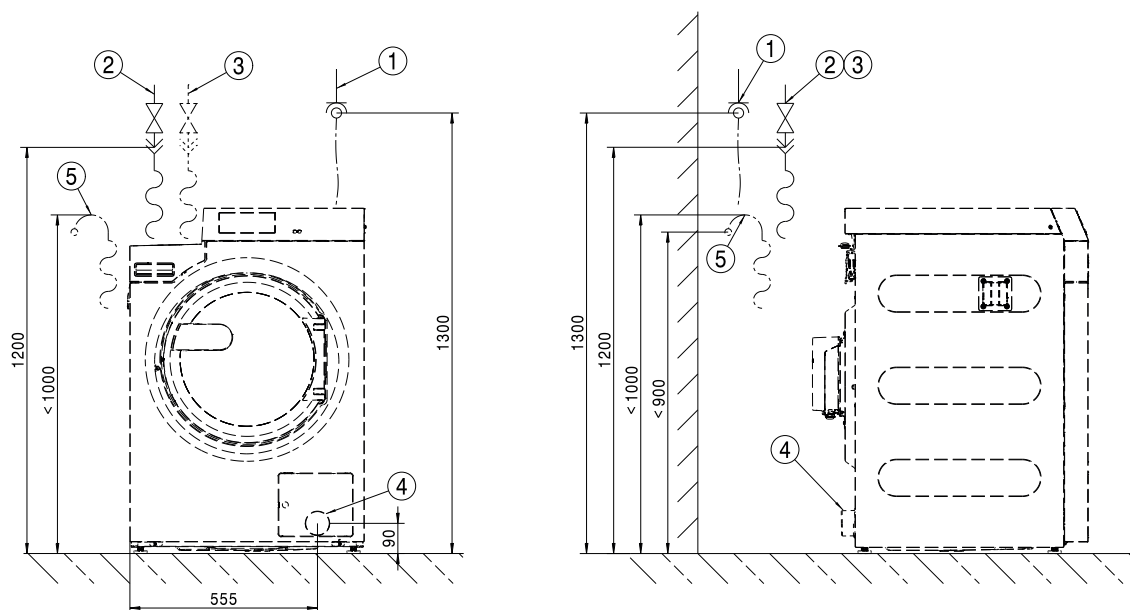

- ① Electrical connection
- ② Cold water connection
- ③ Hot water connection
- ④ Drain pipe (DV versions only)
- ⑤ Drain connection (DP versions only)

Installation

Standard

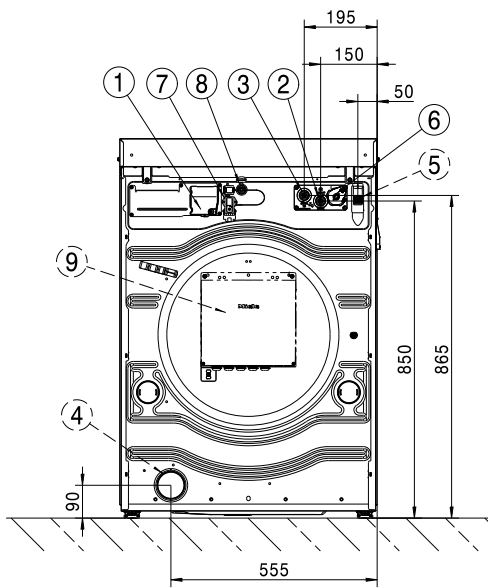

- ① Electrical connection
- ② Cold water connection
- ③ Hot water connection
- ④ Drain pipe (DV versions only)
- ⑤ Drain connection (DP versions only)
- ⑥ Dispenser pump connection
- ⑦ Connector Box connection
- ⑧ LAN connection
- ⑨ Connector Box (optional)

Plinth

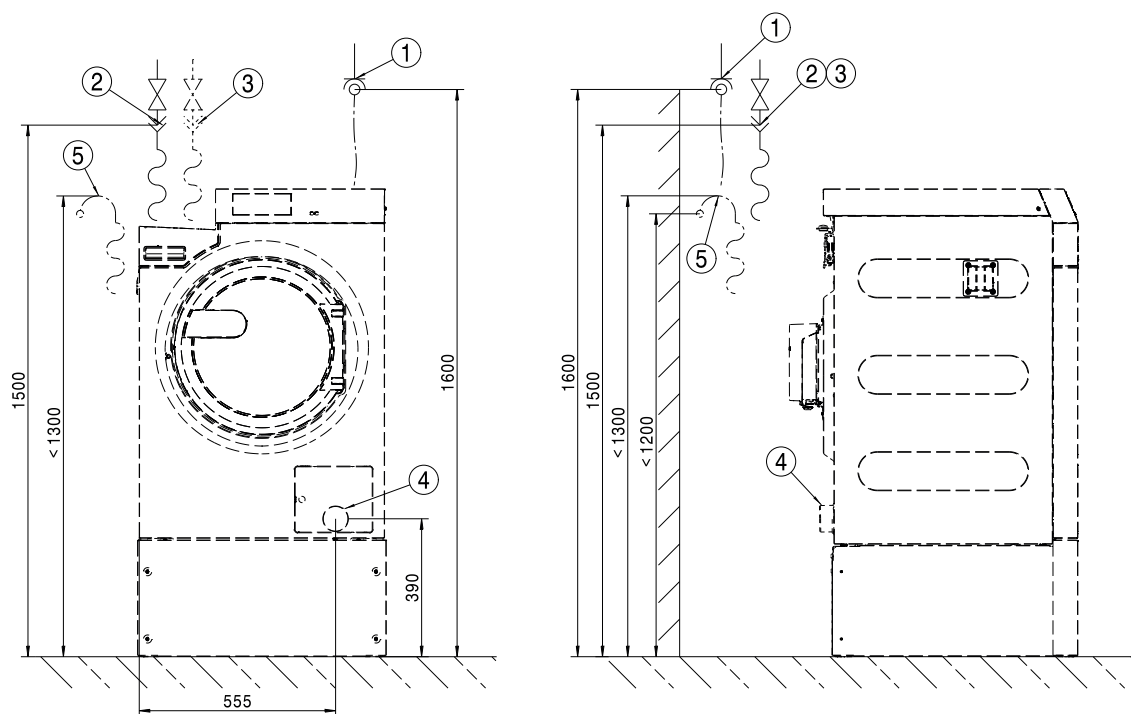

- ① Electrical connection
- ② Cold water connection
- ③ Hot water connection
- ④ Drain pipe (DV versions only)
- ⑤ Drain connection (DP versions only)

Installation

Plinth

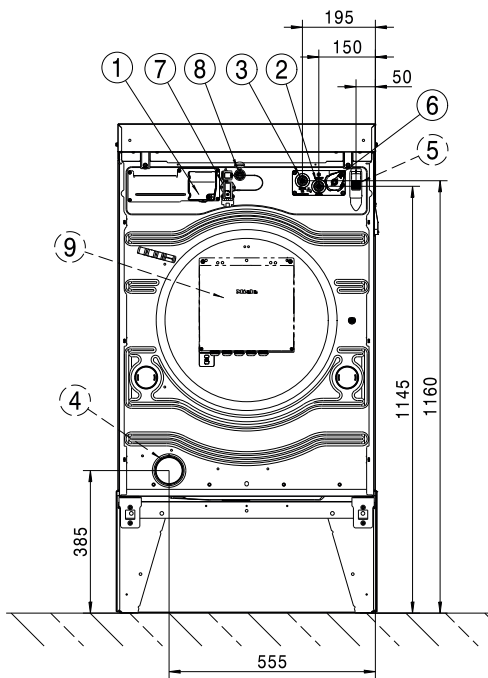

- ① Electrical connection
- ② Cold water connection
- ③ Hot water connection
- ④ Drain pipe (DV versions only)
- ⑤ Drain connection (DP versions only)
- ⑥ Dispenser pump connection
- ⑦ Connector Box connection
- ⑧ LAN connection
- ⑨ Connector Box (optional)

Standard

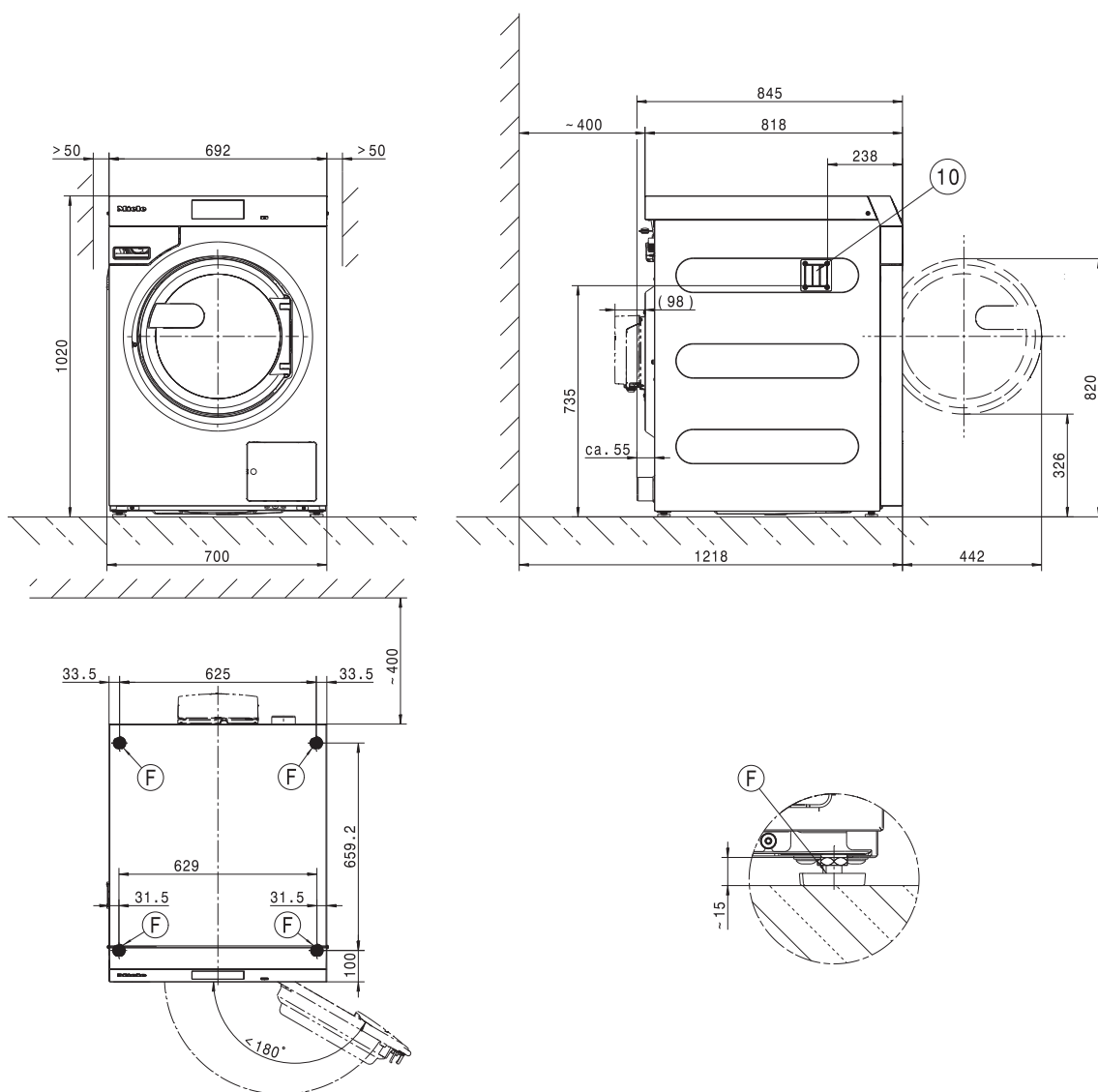

Dimensions in mm

ⓕ Machine foot

⑩ Overflow

Installation

Plinth

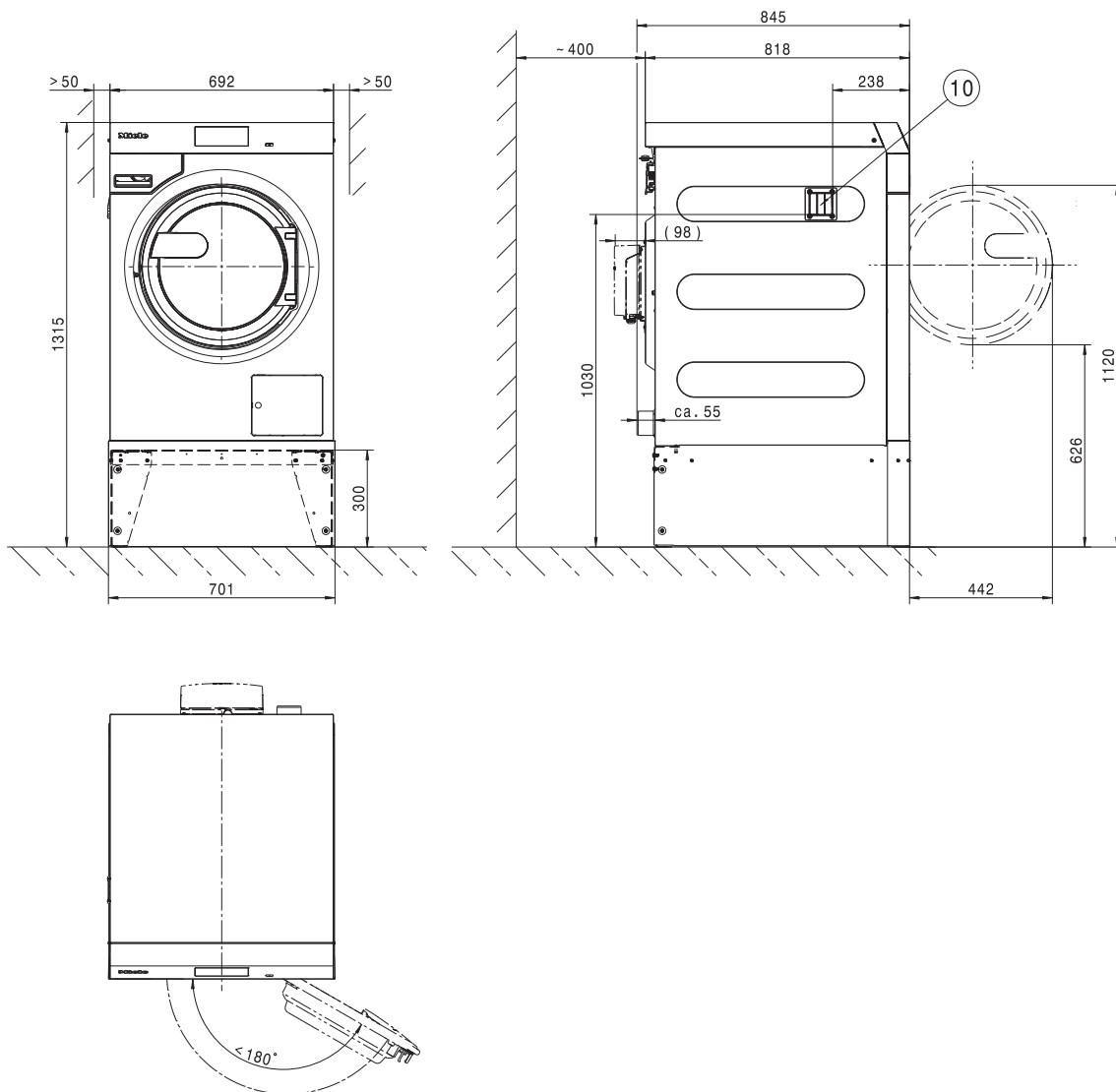

Dimensions in mm

⑨ Machine foot

⑩ Overflow

Securing the machine

Standard

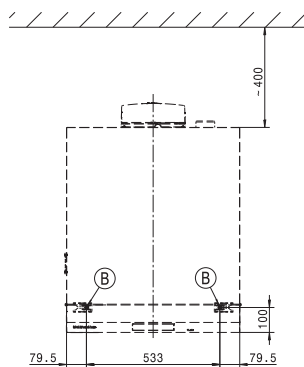
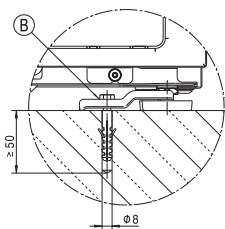

Plinth

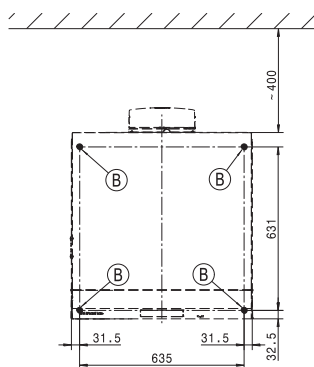
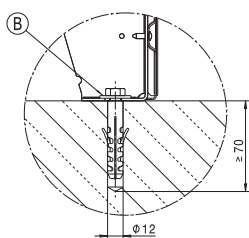

Dimensions in mm

ⓑ Screw/anchor point

Technical data

Voltage versions and electrical data

3N AC 400 V EL DV

Supply voltage	3N AC 400 V
Frequency	50/60 Hz
Required fuse rating (on site)	3 x 16 A
Circuit breaker trip characteristic	Type B
Power rating	8,2 kW
Connection cable, min. cross-section	5 x 1,5 mm ²

3N AC 400 V EL DP

Supply voltage	3N AC 400 V
Frequency	50 Hz
Required fuse rating (on site)	3 x 16 A
Circuit breaker trip characteristic	Type B
Power rating	8,2 kW
Connection cable, min. cross-section	5 x 1,5 mm ²

1N AC 230 V EL DP

Supply voltage	1N AC 230 V
Frequency	50 Hz
Required fuse rating (on site)	1 x 25 A
Circuit breaker trip characteristic	Type B
Power rating	5,5 kW
Connection cable, min. cross-section	3 x 2,5 mm ²

1N AC 230 V EL DV

Supply voltage	1N AC 230 V
Frequency	50/60 Hz
Required fuse rating (on site)	1 x 25 A
Circuit breaker trip characteristic	Type B
Power rating	5,5 kW
Connection cable, min. cross-section	3 x 2,5 mm ²

Plumbing

Cold water connection

Required flow pressure	100 - 1000 kPa (1 - 10 bar)
Maximum flow rate	10 l/min
Threaded union required (male thread, to be provided by customer in accordance with DIN 44991, flat sealing)	3/4"
Length of water inlet hose included in scope of supply	2000 mm

Hot water connection

Maximum permissible hot water temperature	60 °C
Required flow pressure	100 - 1000 kPa (1 - 10 bar)
Maximum flow rate	10 l/min
Threaded union required (male thread, in accordance with DIN 44991, flat sealing)	3/4"
Length of water inlet hose supplied	2000 mm

Drain valve (DV)

Maximum waste water temperature	95 °C
Drain connection (on machine)	Plastic pipe HT DN 70
Drain (on site)	Connection DN 70
Maximum drainage rate	200 l/min

Drainage (DP)

Maximum waste water temperature	95 °C
Drain connection (on machine)	External diameter 22 (DN 22)
Maximum drainage rate	26 l/min

Equipotential bonding

Connection with male thread	10×35 mm
Washers and nuts	M10

If local and national installation specifications require equipotential bonding, good galvanic contact must be guaranteed. Accessories for equipotential bonding are not supplied and need to be ordered separately.

Installation dimensions

Casing width (without add-on components)	692 mm
Casing height (without add-on components)	1012 mm
Casing depth (without add-on components)	818 mm
Overall machine width	700 mm
Overall machine height	1020 mm
Overall machine depth	845 mm
Minimum width of transport opening	800 mm
Minimum safety distance between wall and back of machine	400 mm
Diameter of door opening	370 mm
Door opening angle	180°

Technical data

Anchoring

Standard

Required anchor points	2
DIN 571 wood screw (diameter x length)	12 mm x 90 mm
Rawl plugs (diameter x length)	14 mm x 80 mm

With plinth (APWM)

Required anchor points	4
DIN 571 wood screw (diameter x length)	12 mm x 90 mm
Rawl plugs (diameter x length)	14 mm x 80 mm

Concrete plinth

Required anchor points	2
DIN 571 wood screw (diameter x length)	12 mm x 90 mm
Rawl plugs (diameter x length)	14 mm x 80 mm

Transport data, weight and floor load

Packaging width	750 mm
Packaging height	1214 mm
Packaging depth	917 mm
Gross volume	835 l
Gross weight*	161 kg
Net weight*	148 kg
Maximum floor load in operation*	2577 N

*depending on equipment configuration

Emissions data

Workplace-related sound pressure level, washing	51 dB (A)
Sound power level, washing	60,1 dB (A)
Workplace-related sound pressure level, spinning	60 dB (A)
Sound power level, spinning	68,7 dB (A)
Average heat dissipation rate to installation room	2,8 MJ/h
Emission sound pressure level	61 dB (A) re 20 µPa

United Kingdom

Miele Co. Ltd., Fairacres, Marcham Road
Abingdon, Oxon, OX14 1TW
Professional Sales, Tel: 0845 365 6608
E-mail: professional@miele.co.uk
Internet: www.miele.co.uk/professional

Australia

Miele Australia Pty. Ltd.
ACN 005 635 398, ABN 96 005 635 398
Level 4, 141 Camberwell Road, Hawthorn East, VIC 3123
Tel: 1300 731 411
Internet: www.miele.com.au/professional
E-mail: professional.sales@miele.com.au

China Mainland

Miele Electrical Appliances Co. Ltd.
No. 82, Shimenyi Road, JingAn District,
Shanghai, China, P.R.C, Post Code: 200040
Phone: +86 21 6157 3500, Fax: +86 21 6157 3511
E-mail: info@miele.cn, Internet: www.miele.cn

Hong Kong, China

Miele (Hong Kong) Ltd.
41/F - 4101, Manhattan Place
23 Wang Tai Road, Kowloon Bay, Hong Kong
Tel: (852) 2610 1025, Fax: (852) 3579 1404
Email: customerservices@miele.com.hk
Website: www.miele.hk

India

Miele India Pvt. Ltd.
1st Floor, Copia Corporate Suites,
Commercial Plot 9, Mathura Road, Jasola,
New Delhi - 110025
E-mail: customercare@miele.in, Website: www.miele.in

Ireland

Miele Ireland Ltd.
2024 Bianconi Ave., Citywest Business Campus,
Dublin 24
Tel: (01) 461 07 10, Fax: (01) 461 07 97
E-Mail: info@miele.ie, Internet: www.miele.ie

Malaysia

Miele Sdn Bhd
Suite 12-2, Level 12
Menara Sapura Kencana Petroleum
Solaris Dutamas No. 1, Jalan Dutamas 1
50480 Kuala Lumpur, Malaysia
Phone: +603-6209-0288
Fax: +603-6205-3768

New Zealand

Miele New Zealand Limited
IRD 98 463 631
8 College Hill
Freemans Bay, Auckland 1011, NZ
Tel: 0800 464 353
Internet: www.miele.com.au/professional
E-mail: professional.sales@miele.com.au

Singapore

Miele Pte. Ltd.
29 Media Circle, #11-04 ALICE@Mediapolis
Singapore 138565
Tel: +65 6735 1191, Fax: +65 6735 1161
E-Mail: info@miele.com.sg
Internet: www.miele.sg

South Africa

Miele (Pty) Ltd
63 Peter Place, Bryanston 2194
P.O. Box 69434, Bryanston 2021
Tel: (011) 875 9000, Fax: (011) 875 9035
E-mail: info@miele.co.za
Internet: www.miele.co.za

United Arab Emirates

Miele Appliances Ltd.
Showroom 1, Eiffel 1 Building
Sheikh Zayed Road, Umm Al Sheif
P.O. Box 114782 - Dubai
Tel. +971 4 3044 999, Fax. +971 4 3418 852
800-MIELE (64353)
E-Mail: info@miele.ae
Website: www.miele.ae



Manufacturer: Miele & Cie. KG, Carl-Miele-Straße 29, 33332 Gütersloh, Germany